

iC-MHA

HALL ANGLE ENCODER WITH SIN/COS OUTPUTS

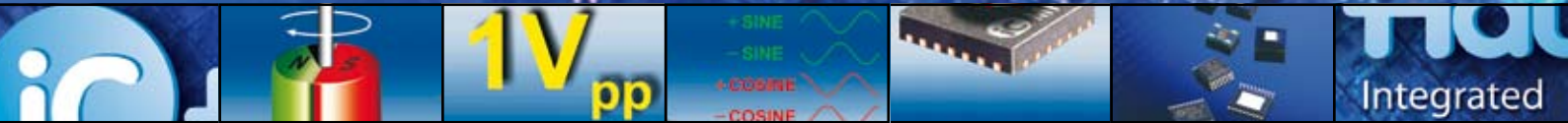
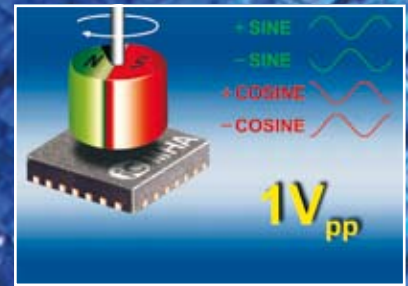

The iC-MHA is an integrated Hall device for sensing the angular position of a diametral magnet. With the internal signal conditioning, sine and cosine components of the magnetic field direction are available on buffered outputs. By using differential Hall sensors for both sine and cosine sensing, the device is insensitive to homogenous magnetic stray fields.

To compensate for variations in magnetic working distance, temperature and drift, the differential output signals are regulated to 1 Vpp. The outputs are designed to drive differential resistive loads down to 100 Ω .

Features

- Sine/cosine differential outputs
- Automatic gain control for 1 Vpp differential signal amplitude
- Operating speed from DC to 20 000 RPM
- Loss-of-magnet detection and error messaging

Applications

- Resolver replacement
- Contactless rotary sensor / potentiometer
- Absolute and incremental rotary encoders
- Motor feedback

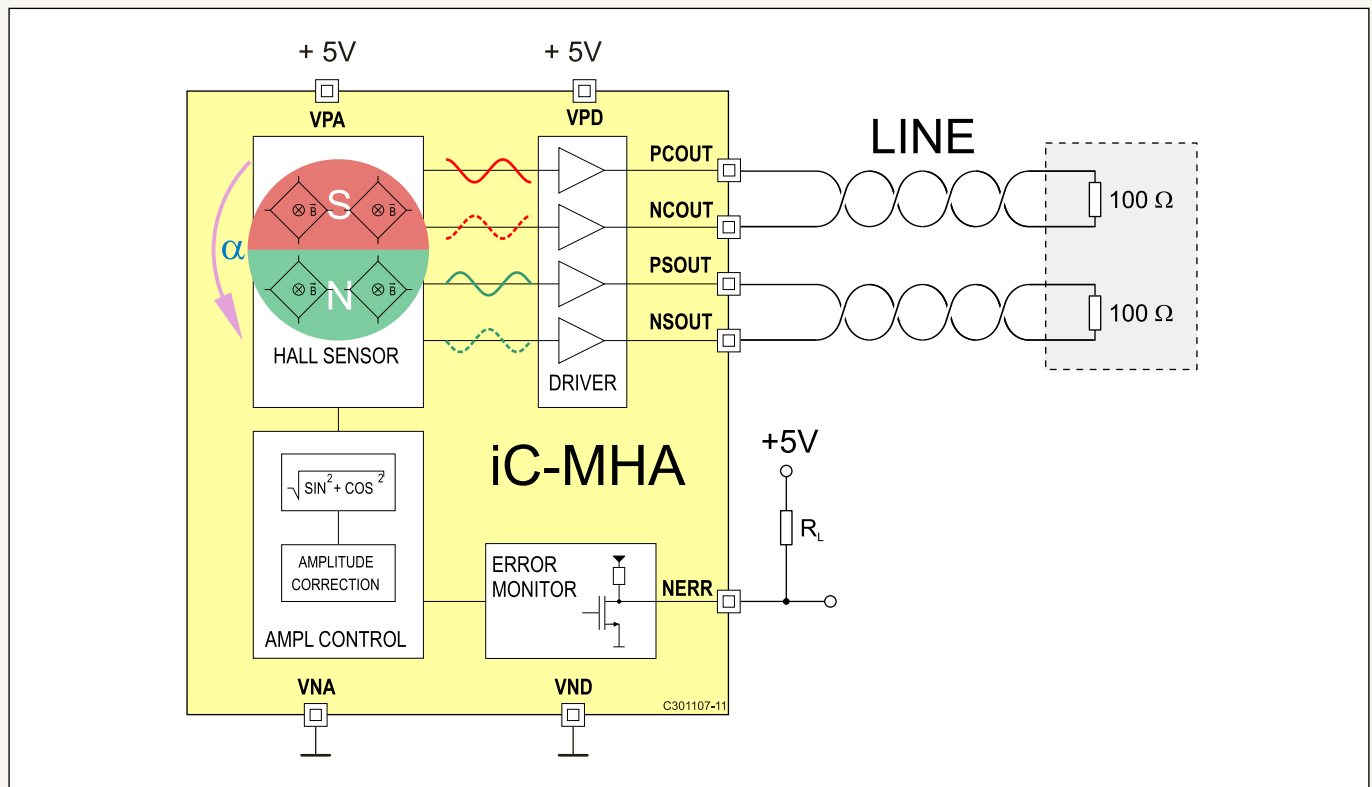



iC-MHA HALL ANGLE ENCODER WITH SIN/COS OUTPUTS

Key Specifications

General	
Supply Voltage	5 V \pm 10 %
Supply Current, no load	30 mA max.
Magnetic Field Strength	20 ... 100 kA/m
Operating speed of magnet	DC to 20.000 RPM
Output Drivers Capability	1 V _{pp} diff. to 100 Ω
Operational Temperature Range	-40 to +125 °C
ESD Susceptibility	2 kV (HBM 100 pF, 1.5 k Ω)
Angle Accuracy	typ. 0.2 degree (chip axis centered to field axis)
Angle Repeatability	typ. 0.1 degree

Output Signal vs. Magnet Position

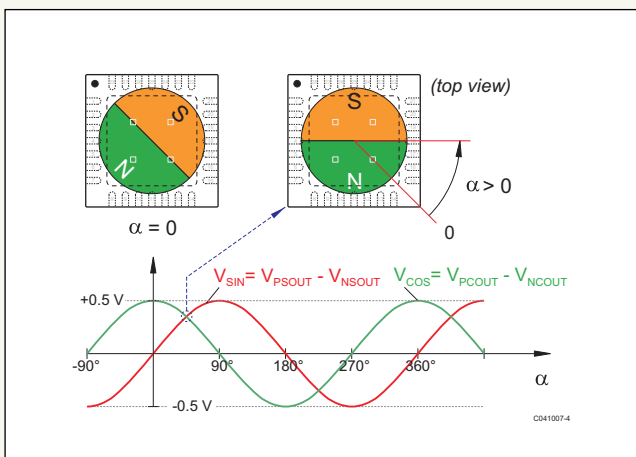

Pin Functions

No.	Name	Function
2	NERR	Error Message Output (active low)
3	VPA	+5 V Analog Supply Voltage
4	VNA	Analog Ground
10	PCOUT	Positive Cosine Output
11	NCOUT	Negative Cosine Output
18	VND	Digital Ground
19	VPD	+5 V Digital Supply Voltage
25	NSOUT	Negative Sine Output
26	PSOUT	Positive Sine Output
TP		Thermal-Pad
8, 9	n.c.	not connected
13, 14	n.c.	not connected
23, 24	n.c.	not connected
27, 28	n.c.	not connected

Pins for device test and factory calibration:

1	PT1	connect to VND
5	PT5	connect to VND
6	PT6	connect to VPD
7	PT7	not to be connected
12	PT12	connect to VND
15	PT15	connect to VND
16	PT16	connect to VND
17	PT17	connect to VND
20	PT20	connect to VND
21	PT21	connect to VND
22	PT22	connect to VND

Application Example

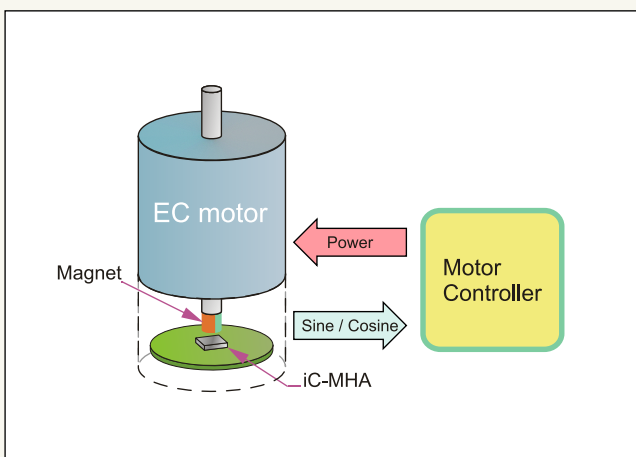

Pin Configuration QFN28 5x5 mm²

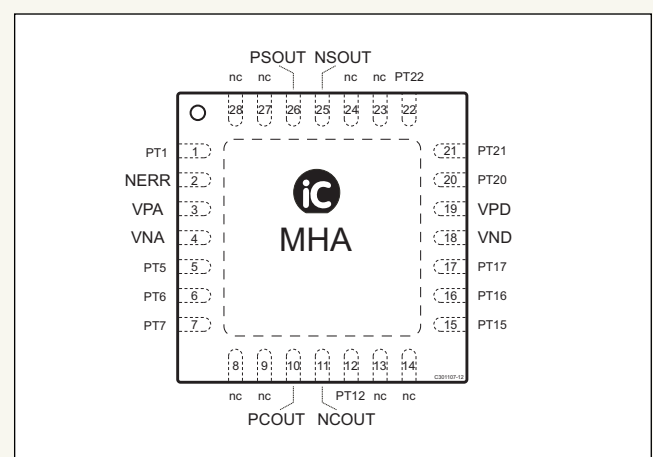

This tentative information shall not be considered as a guarantee of characteristics. Rights to technical changes reserved.