

## PFM/PWM Step-Up DC/DC Converter

### Features

- High Efficiency at Low Output Load Currents via PFM Mode
- Assured Start-up at 0.9V
- 80 $\mu$ A (Typ) Supply Current
- 85% Typical Efficiency at 100mA
- 140mA Typical Output Current @  $V_{IN} = 2.0V$
- Low Power Shutdown Mode
- No External Switching Transistor Needed
- Space Saving SOT-89 Package

### Applications

- Pagers
- Cellular Phones
- Palmtops
- 1-Cell to 3-Cell Battery Powered Systems
- Cameras, Video Recorders
- Local +3V to +5V Supplies

### Device Selection Table

Part Number	Output Voltage (V)*	Package	Osc. Freq. (kHz)	Operating Temp. Range
TC115501ECT	5.0	SOT-89-5	100	-40°C to +85°C
TC115331ECT	3.3	SOT-89-5	100	-40°C to +85°C
TC115301ECT	3.0	SOT-89-5	100	-40°C to +85°C

\*Other output voltages are available. Please contact Microchip Technology for details.

### Package Type

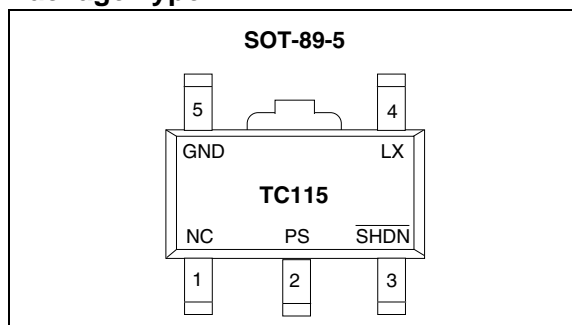

### General Description

The TC115 is a high-efficiency step-up DC/DC converter for small, low input voltage or battery powered systems. This device has a start-up voltage of 0.9V and a typical supply current of 80 $\mu$ A. Phase compensation and soft-start circuitry are included on-chip. Unlike conventional PWM step-up converters, the TC115 automatically shifts to pulse frequency modulation (PFM) at low loads, resulting in reduced supply current and improved efficiency.

The TC115 requires only an external diode, an inductor, and a capacitor, and supports typical output currents of 140mA. Supply current is reduced to less than 0.5 $\mu$ A, max when SHDN input is brought low.

Small size, low installed cost, and low supply current make the TC115 step-up converter ideal for use in a wide range of battery powered systems.

### Functional Block Diagram

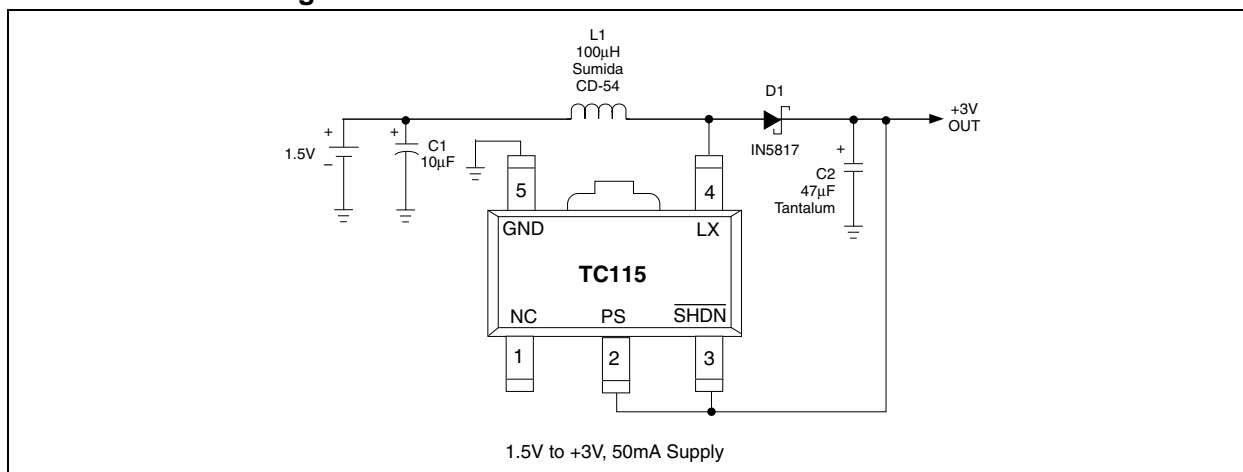

# TC115

## 1.0 ELECTRICAL CHARACTERISTICS

### Absolute Maximum Ratings\*

Power Supply Voltage (PS).....	12V
Power Dissipation.....	500mW
LX Sink Current.....	400mA pk
$\overline{\text{SHDN}}$ Input Voltage.....	12V
Operating Temperature Range.....	-40°C to +85°C
Storage Temperature Range.....	-40°C to +125°C

\*Stresses above those listed under "Absolute Maximum Ratings" may cause permanent damage to the device. These are stress ratings only and functional operation of the device at these or any other conditions above those indicated in the operation sections of the specifications is not implied. Exposure to Absolute Maximum Rating conditions for extended periods may affect device reliability.

### TC115 ELECTRICAL SPECIFICATIONS

Electrical Characteristics: $V_{OUT} = 5V$ , $T_A = 25^\circ C$ , unless otherwise noted. Circuit configuration per Figure 4-1.						
Symbol	Parameter	Min	Typ	Max	Units	Test Conditions
$V_{IN}$	Operating Supply Voltage	0.9	—	10.0	V	Note 5
$V_{START}$	Start-Up Supply Voltage	—	—	0.9	V	$I_{OUT} = 1mA$
$I_{LXMAX}$	LX Maximum Sink Current	—	—	350	mA	
$f_{LIM}$	LX Limit Frequency	—	200	—	kHz	$V_{LX} = VLX_{LIM}$
$VLX_{LIM}$	LX Limit Voltage	0.7	—	1.3	V	Note 2
$I_{DD}$	No Load Supply Current	—	13	26	$\mu A$	$I_{OUT} = 0$ , $V_{IN} = V_{OUT} \times 0.8$ (Note3)
$I_{CC}$	Boost Mode Supply Current	—	80	135	$\mu A$	No external components, $V_{IN} = (0.95 \times V_{OUT})$ applied to PS (or $V_{DD}$ ) input
$I_{STBY}$	Standby Supply Current	—	9	17	$\mu A$	No external components, $V_{IN} = (1.1 \times V_{OUT})$ applied to PS (or $V_{DD}$ ) input
$I_{SD}$	Shutdown Supply Current	—	—	0.5	$\mu A$	$\overline{\text{SHDN}} = 0V$
$f_{OSC}$	Oscillator Frequency	85	100	115	kHz	Note 2, Note 4
$V_{OUT}$	Output Voltage	$V_R \times 0.975$	$V_R$	$V_R \times 1.025$	V	$V_{IN} = 2.2V$ minimum (Note 1)
R <sub>SWON</sub>	LX Output ON Resistance	—	1.4	2.4	$\Omega$	$V_{LX} = 0.4V$
PFMDUTY	Duty Cycle (PFM Operating Mode)	10	17	25	%	No external components.
MAXDUTY	Maximum Duty Cycle	80	87	92	%	Note 4
$t_{SS}$	Soft Start Time	4	10	20	msec	
$\eta$	Efficiency	—	85	—	%	
$V_{IH}$	$\overline{\text{SHDN}}$ Input Logic High	0.75	—	—	V	
$V_{IL}$	$\overline{\text{SHDN}}$ Input Logic Low	—	—	0.20	V	

- Note**
- 1:  $V_R$  is the nominal factory-programmed output voltage setting.
  - 2:  $VLX_{LIM}$  is the voltage on the LX pin (with internal switch ON) that will cause the oscillator to run at twice nominal frequency in to limit the switch current through the internal N-channel switching transistor.
  - 3: Measured with D1 = MA735 (reverse current < 1 $\mu A$  at a reverse voltage of 10V).
  - 4: With TC115 operating in PWM mode.
  - 5: See Section 3.4 "Behavior When  $V_{IN}$  is Greater Than the Factory-Programmed  $V_{OUT}$  Setting".

## 2.0 PIN DESCRIPTIONS

The descriptions of the pins are listed in Table 2-1.

**TABLE 2-1: PIN FUNCTION TABLE**

Pin No. (SOT-89-5)	Symbol	Description
1	NC	Not connected.
2	PS	Power and voltage sense input. This dual function input provides both feedback voltage sensing and internal chip power. It should be connected to the regulator output. (See Section 4.0, Applications).
3	$\overline{\text{SHDN}}$	Shutdown input. A logic low on this input suspends device operation and supply current is reduced to less than 0.5 $\mu$ A. The device resumes normal operation when $\overline{\text{SHDN}}$ is again brought high.
4	LX	Inductor switch output. LX is the drain of an internal N-channel switching transistor. This terminal drives the external inductor, which ultimately provides current to the load.
5	GND	Ground terminal.

## 3.0 DETAILED DESCRIPTION

The TC115 is a combination PFM/PWM step-up (boost) regulator. It is particularly useful in 1, 2 and 3 cell applications where the required output current is 140mA or less, and size/cost issues are a concern. The device operates in PWM mode when the output load is sufficient to demand a 10% (or greater) duty cycle. While in PWM mode, the TC115 behaves as any other PWM switching regulator, to a maximum duty cycle of 92%. At low output loads (i.e., output loads requiring < 10% duty cycle to support); the TC115 automatically switches to pulse frequency modulation (PFM) operating mode with a fixed duty cycle of 25%, max, (17%, typical). While in PFM mode, the inductor is modulated with individual fixed width pulses only as needed to maintain output voltage. This action reduces supply current, thereby improving power efficiency at low output loads.

### 3.1 Input Power and Sensing

The TC115 is powered from the PS input, which *must* be connected to the regulated output as shown in Figure 4-1. PS also senses output voltage for closed-loop regulation. Start-up current is furnished through the inductor when input voltage is initially applied. This action starts the oscillator, causing the voltage at the PS input to rise, bootstrapping the regulator into full operation.

### 3.2 Output Diode

For best results, use a Schottky diode such as the MA735, 1N5817, EC10 or equivalent. Connect the diode between the PS and LX pins as close to the IC as possible. Do not use ordinary rectifier diodes since the higher forward voltages reduce efficiency.

### 3.3 Low Power Shutdown Mode

The TC115 enters a low power shutdown mode when  $\overline{\text{SHDN}}$  is brought low. While in shutdown, the oscillator is disabled and the internal switch is shut off. Normal regulator operation resumes when  $\overline{\text{SHDN}}$  is brought high.  $\overline{\text{SHDN}}$  may be tied to the input supply if not used.

**Note:** Because the TC115 uses an external diode, a leakage path between the input voltage and the output node (through the inductor and diode) exists while the regulator is in shutdown. Care must be taken in system design to assure the input supply is isolated from the load during shutdown.

### 3.4 Behavior When $V_{\text{IN}}$ is Greater Than the Factory-Programmed $V_{\text{OUT}}$ Setting

The TC115 is designed to operate as a step-up regulator only. As such,  $V_{\text{IN}}$  is assumed to always be less than the factory-programmed  $V_{\text{OUT}}$  setting ( $V_{\text{R}}$ ). Operating the TC115 with  $V_{\text{IN}} > V_{\text{R}}$  causes regulating action to be suspended (and corresponding supply current reduction to 9 $\mu\text{A}$ , typical) until  $V_{\text{IN}}$  is again less than  $V_{\text{R}}$ . While regulating action is suspended,  $V_{\text{IN}}$  is connected to  $V_{\text{OUT}}$  through the series combination of the inductor and Schottky diode. Care must be taken to add the appropriate isolation (MOSFET output switch or post LDO with shutdown) during system design if this  $V_{\text{IN}}/V_{\text{OUT}}$  leakage path is problematic.

## 4.0 APPLICATIONS

### 4.1 Input Bypass Capacitors

Using an input bypass capacitor reduces peak current transients drawn from the input supply and reduces the switching noise generated by the regulator. The source impedance of the input supply determines the size of the capacitor that should be used.

**FIGURE 4-1: TC115 TYPICAL APPLICATION**

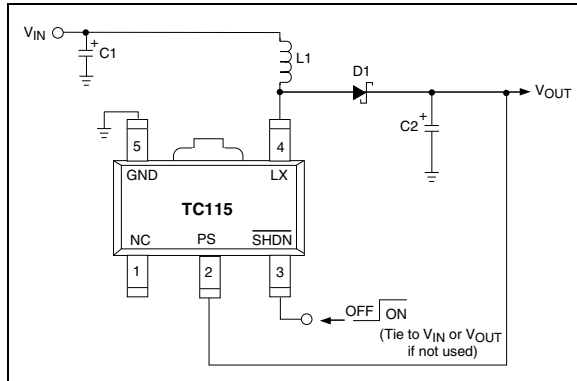

### 4.2 Inductor Selection

Selecting the proper inductor value is a trade-off between physical size and power conversion requirements. Lower value inductors cost less, but result in higher ripple current and core losses. They are also more prone to saturate since the coil current ramps to a higher value. Larger inductor values reduce both ripple current and core losses, but are larger in physical size and tend to increase the start-up time slightly.

Practical inductor values, therefore, range from 50 $\mu$ H to 300 $\mu$ H. Inductors with a ferrite core (or equivalent) are recommended. For highest efficiency, use an inductor with a series resistance less than 20 m $\Omega$ .

The inductor value directly affects the output ripple voltage. Equation 4-3 is derived as shown below, and can be used to calculate an inductor value, given the required output ripple voltage ( $V_{RIPPLE}$ ) and output capacitor series resistance:

**EQUATION 4-1:**

$$V_{RIPPLE} \approx ESR(di)$$

where ESR is the equivalent series resistance of the output filter capacitor, and  $V_{RIPPLE}$  is in volts.

Expressing  $di$  in terms of switch ON resistance and time:

**EQUATION 4-2:**

$$V_{RIPPLE} \approx \frac{ESR [(V_{IN} - V_{SW})t_{ON}]}{L}$$

Solving for L:

**EQUATION 4-3:**

$$L \approx \frac{ESR [(V_{IN} - V_{SW})t_{ON}]}{V_{RIPPLE}}$$

Care must be taken to ensure the inductor can handle peak switching currents, which can be several times load currents. Exceeding rated peak current will result in core saturation and loss of inductance. The inductor should be selected to withstand currents greater than  $I_{PK}$  (Equation 4-10) without saturating.

Calculating the peak inductor current is straightforward. Inductor current consists of an AC (sawtooth) current centered on an average DC current (i.e., input current). Equation 4-6 calculates the average DC current. Note that minimum input voltage and maximum load current values should be used:

**EQUATION 4-4:**

$$\text{Input Power} = \frac{\text{Output Power}}{\text{Efficiency}}$$

# TC115

Re-writing in terms of input and output currents and voltages:

## EQUATION 4-5:

$$(V_{INMIN}) (I_{INMAX}) = \frac{(V_{OUTMAX}) (I_{OUTMAX})}{\text{Efficiency}}$$

Solving for input current:

## EQUATION 4-6:

$$I_{INMAX} = \frac{(V_{OUTMAX})(I_{OUTMAX})}{(\text{Efficiency})(V_{INMAX})}$$

The sawtooth current is centered on the DC current level; swinging equally above and below the DC current calculated in Equation 4-6. The peak inductor current is the sum of the DC current plus half the AC current. Note that minimum input voltage should be used when calculating the AC inductor current (Equation 4-9).

## EQUATION 4-7:

$$V = \frac{L(di)}{dt}$$

## EQUATION 4-8:

$$di = \frac{V(dt)}{dt}$$

## EQUATION 4-9:

$$di = \frac{[(V_{INMIN} - V_{SW})t_{ON}]}{L}$$

where:  $V_{SW}$  = The voltage drop across the internal N-channel MOSFET.

Combining the DC current calculated in Equation 4-6, with half the peak AC current calculated in Equation 4-9, the peak inductor current is given by:

## EQUATION 4-10:

$$I_{PK} = I_{INMAX} + 0.5(di)$$

## 4.3 Internal Transistor Switch

The LX pin has a typical ON resistance of 1.4Ω, therefore peak switch current is given by  $(V_{IN}/1.4)$ . The internal transistor switch has a maximum design rating of 350mA. An oscillator frequency doubling circuit is included guard against high switching currents. Should the voltage on the LX pin rise above 1.3V, max, while the internal N-channel switch is ON, the oscillator frequency automatically doubles to minimize ON time. Although reduced, switch current still flows because the PWM remains in operation. *Therefore, the LX input is not internally current limited and care must be taken never to exceed the 350mA maximum limit.* Failure to observe this will result in damage to the regulator.

## 4.4 Output Capacitor

The effective series resistance of the output capacitor directly affects the amplitude of the output voltage ripple. (The product of the peak inductor current and the ESR determines output ripple amplitude.) Therefore, a capacitor with the lowest possible ESR should be selected. Smaller capacitors are acceptable for light loads or in applications where ripple is not a concern. The Sprague 595D series of tantalum capacitors are among the smallest of all low ESR surface mount capacitors available. Table 4-1 lists suggested components and suppliers.

## 4.5 Board Layout Guidelines

As with all inductive switching regulators, the TC115 generates fast switching waveforms which radiate noise. Interconnecting lead lengths should be minimized to keep stray capacitance, trace resistance and radiated noise as low as possible. In addition, the GND pin, input bypass capacitor and output filter capacitor ground leads should be connected to a single point. The input capacitor should be placed as close to power and ground pins of the TC115 as possible.

TABLE 4-1: SUGGESTED COMPONENTS AND SUPPLIERS

Type	Inductors	Capacitors	Diodes
Surface Mount	Sumida CD54 Series CDR125 Series  Coiltronics CTX Series	Matsuo 267 Series  Sprague 595D Series  Nichicon F93 Series	Nihon EC10 Series  Matsushita MA735 Series
Through-Hole	Sumida RCH855 Series RCH110 Series  Renco RL1284-12	Sanyo OS-CON Series  Nichicon PL Series	ON Semiconductor 1N5817 - 1N5822

**FIGURE 4-2: TYPICAL RIPPLE WAVEFORMS**

**TC115301**  
 $V_{IN} = 1.0V$   
 $I_{LOAD} = 10mA$   
**CH1:  $V_{OUT}$  (DC)**  
**CH2:  $V_{OUT}$  (AC Ripple)**  
 $L = 100\mu H$   
 $C = 47\mu F$   
**D1 = MA735**

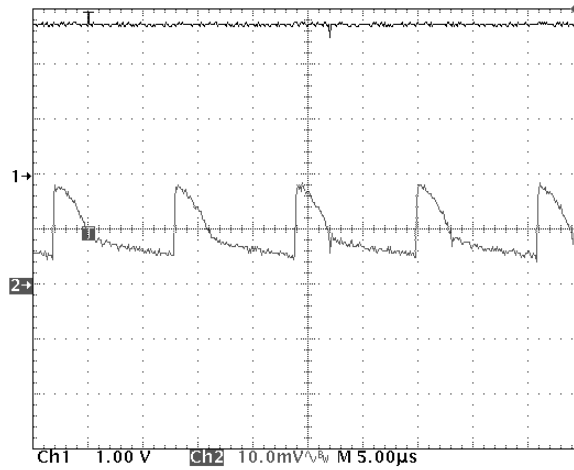

**TC115301**  
 $V_{IN} = 2.0V$   
 $I_{LOAD} = 40mA$   
**CH1:  $V_{OUT}$  (DC)**  
**CH2:  $V_{OUT}$  (AC Ripple)**  
 $L = 100\mu H$   
 $C = 47\mu F$   
**D1 = MA735**

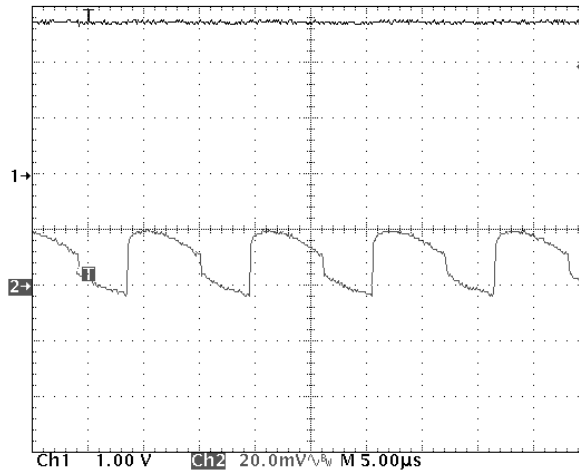

**TC115301**  
 $V_{IN} = 2.5V$   
 $I_{LOAD} = 80mA$   
**CH1:  $V_{OUT}$  (DC)**  
**CH2:  $V_{OUT}$  (AC Ripple)**  
 $L = 100\mu H$   
 $C = 47\mu F$   
**D1 = MA735**

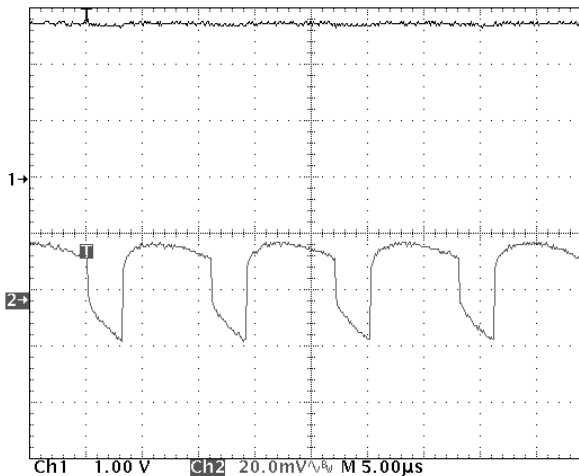

## 5.0 TYPICAL CHARACTERISTICS

(Unless Otherwise Specified, All Parts Are Measured At Temperature = 25°C)

**Note:** The graphs and tables provided following this note are a statistical summary based on a limited number of samples and are provided for informational purposes only. The performance characteristics listed herein are not tested or guaranteed. In some graphs or tables, the data presented may be outside the specified operating range (e.g., outside specified power supply range) and therefore outside the warranted range.

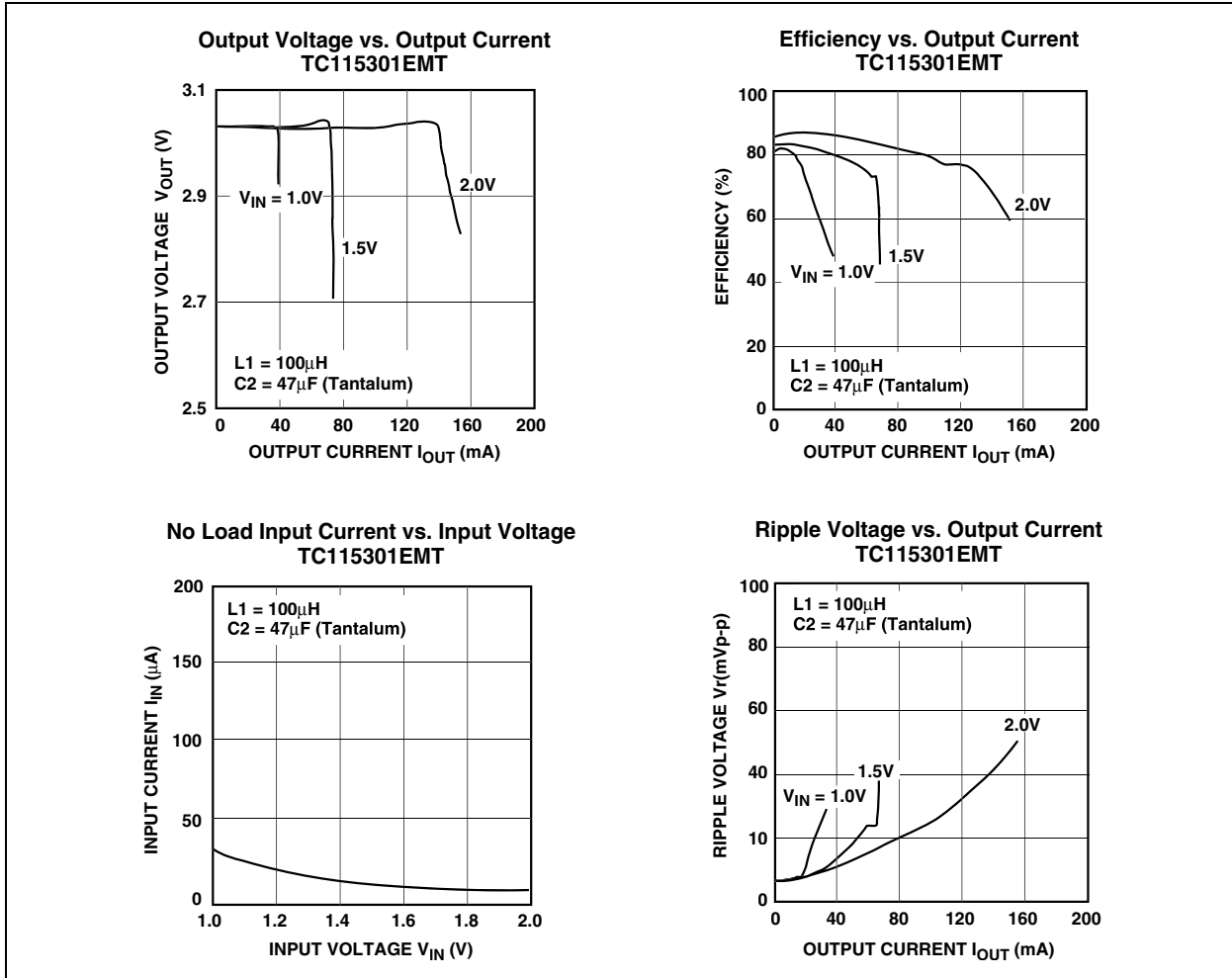



## 6.0 PACKAGING INFORMATION

### 6.1 Package Marking Information

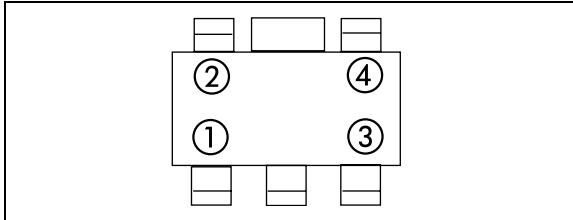

① represents product classification; TC115 = 1

② represents first integer of voltage and frequency

Symbol (100kHz)	Voltage
1	1.
2	2.
3	3.
4	4.
5	5.
6	6.

③ represents first decimal of voltage and frequency

Symbol (100kHz)	Voltage
0	.0
1	.1
2	.2
3	.3
4	.4
5	.5
6	.6
7	.7
8	.8
9	.9

④ represents production lot ID code

Example: For TC115331, the marking code is:

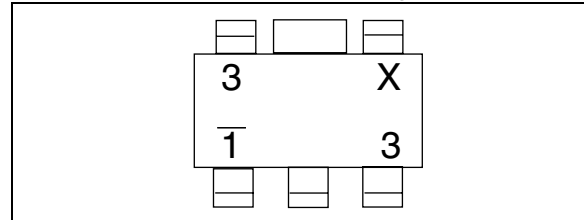

## 6.2 Taping Form

### Component Taping Orientation for 5-Pin SOT-89 Devices

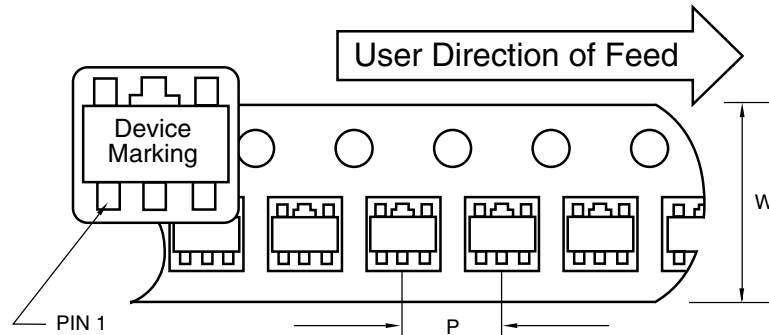

Standard Reel Component Orientation  
 TR Suffix Device  
 (Mark Right Side Up)

#### Carrier Tape, Number of Components Per Reel and Reel Size

Package	Carrier Width (W)	Pitch (P)	Part Per Full Reel	Reel Size
5-Pin SOT-89	12 mm	8 mm	1000	7 in

## 6.3 Package Dimensions

### SOT-89-5

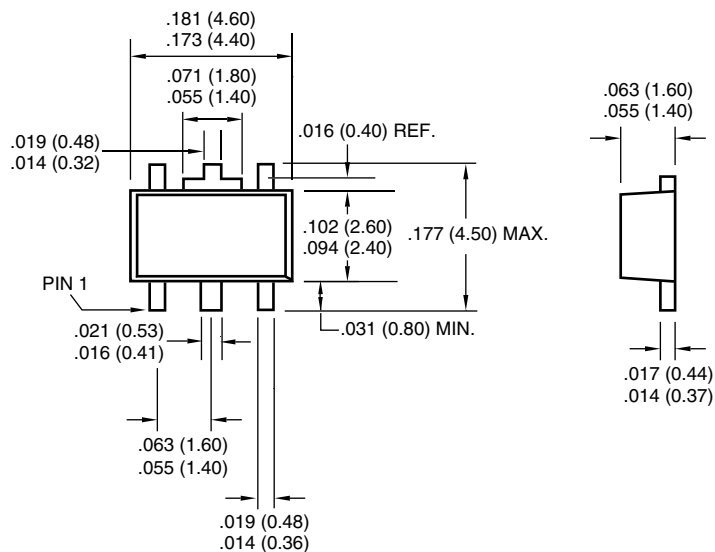

Dimensions: inches (mm)

## **Sales and Support**

### **Data Sheets**

Products supported by a preliminary Data Sheet may have an errata sheet describing minor operational differences and recommended workarounds. To determine if an errata sheet exists for a particular device, please contact one of the following:

1. Your local Microchip sales office
2. The Microchip Corporate Literature Center U.S. FAX: (480) 792-7277
3. The Microchip Worldwide Site ([www.microchip.com](http://www.microchip.com))

Please specify which device, revision of silicon and Data Sheet (include Literature #) you are using.

### **New Customer Notification System**

Register on our web site ([www.microchip.com/cn](http://www.microchip.com/cn)) to receive the most current information on our products.

# TC115

---

NOTES:

Information contained in this publication regarding device applications and the like is intended through suggestion only and may be superseded by updates. It is your responsibility to ensure that your application meets with your specifications. No representation or warranty is given and no liability is assumed by Microchip Technology Incorporated with respect to the accuracy or use of such information, or infringement of patents or other intellectual property rights arising from such use or otherwise. Use of Microchip's products as critical components in life support systems is not authorized except with express written approval by Microchip. No licenses are conveyed, implicitly or otherwise, under any intellectual property rights.

## Trademarks

The Microchip name and logo, the Microchip logo, FilterLab, KEELOQ, microID, MPLAB, PIC, PICmicro, PICMASTER, PICSTART, PRO MATE, SEEVAL and The Embedded Control Solutions Company are registered trademarks of Microchip Technology Incorporated in the U.S.A. and other countries.

dsPIC, ECONOMONITOR, FanSense, FlexROM, fuzzyLAB, In-Circuit Serial Programming, ICSP, ICEPIC, microPort, Migratable Memory, MPASM, MPLIB, MPLINK, MPSIM, MXDEV, MXLAB, PICC, PICDEM, PICDEM.net, rPIC, Select Mode and Total Endurance are trademarks of Microchip Technology Incorporated in the U.S.A.

Serialized Quick Turn Programming (SQTP) is a service mark of Microchip Technology Incorporated in the U.S.A.

All other trademarks mentioned herein are property of their respective companies.

© 2002, Microchip Technology Incorporated, Printed in the U.S.A., All Rights Reserved.

 Printed on recycled paper.



*Microchip received QS-9000 quality system certification for its worldwide headquarters, design and wafer fabrication facilities in Chandler and Tempe, Arizona in July 1999 and Mountain View, California in March 2002. The Company's quality system processes and procedures are QS-9000 compliant for its PICmicro® 8-bit MCUs, KEELOQ® code hopping devices, Serial EEPROMs, microperipherals, non-volatile memory and analog products. In addition, Microchip's quality system for the design and manufacture of development systems is ISO 9001 certified.*



# MICROCHIP

## WORLDWIDE SALES AND SERVICE

### AMERICAS

#### Corporate Office

2355 West Chandler Blvd.  
Chandler, AZ 85224-6199  
Tel: 480-792-7200 Fax: 480-792-7277  
Technical Support: 480-792-7627  
Web Address: <http://www.microchip.com>

#### Rocky Mountain

2355 West Chandler Blvd.  
Chandler, AZ 85224-6199  
Tel: 480-792-7966 Fax: 480-792-7456

#### Atlanta

500 Sugar Mill Road, Suite 200B  
Atlanta, GA 30350  
Tel: 770-640-0034 Fax: 770-640-0307

#### Boston

2 Lan Drive, Suite 120  
Westford, MA 01886  
Tel: 978-692-3848 Fax: 978-692-3821

#### Chicago

333 Pierce Road, Suite 180  
Itasca, IL 60143  
Tel: 630-285-0071 Fax: 630-285-0075

#### Dallas

4570 Westgrove Drive, Suite 160  
Addison, TX 75001  
Tel: 972-818-7423 Fax: 972-818-2924

#### Detroit

Tri-Atria Office Building  
32255 Northwestern Highway, Suite 190  
Farmington Hills, MI 48334  
Tel: 248-538-2250 Fax: 248-538-2260

#### Kokomo

2767 S. Albright Road  
Kokomo, Indiana 46902  
Tel: 765-864-8360 Fax: 765-864-8387

#### Los Angeles

18201 Von Karman, Suite 1090  
Irvine, CA 92612  
Tel: 949-263-1888 Fax: 949-263-1338

#### New York

150 Motor Parkway, Suite 202  
Hauppauge, NY 11788  
Tel: 631-273-5305 Fax: 631-273-5335

#### San Jose

Microchip Technology Inc.  
2107 North First Street, Suite 590  
San Jose, CA 95131  
Tel: 408-436-7950 Fax: 408-436-7955

#### Toronto

6285 Northam Drive, Suite 108  
Mississauga, Ontario L4V 1X5, Canada  
Tel: 905-673-0699 Fax: 905-673-6509

### ASIA/PACIFIC

#### Australia

Microchip Technology Australia Pty Ltd  
Suite 22, 41 Rawson Street  
Epping 2121, NSW  
Australia  
Tel: 61-2-9868-6733 Fax: 61-2-9868-6755

#### China - Beijing

Microchip Technology Consulting (Shanghai)  
Co., Ltd., Beijing Liaison Office  
Unit 915  
Bei Hai Wan Tai Bldg.  
No. 6 Chaoyangmen Beidajie  
Beijing, 100027, No. China  
Tel: 86-10-85282100 Fax: 86-10-85282104

#### China - Chengdu

Microchip Technology Consulting (Shanghai)  
Co., Ltd., Chengdu Liaison Office  
Rm. 2401, 24th Floor,  
Ming Xing Financial Tower  
No. 88 TIDU Street  
Chengdu 610016, China  
Tel: 86-28-86766200 Fax: 86-28-86766599

#### China - Fuzhou

Microchip Technology Consulting (Shanghai)  
Co., Ltd., Fuzhou Liaison Office  
Unit 28F, World Trade Plaza  
No. 71 Wusi Road  
Fuzhou 350001, China  
Tel: 86-591-7503506 Fax: 86-591-7503521

#### China - Shanghai

Microchip Technology Consulting (Shanghai)  
Co., Ltd.  
Room 701, Bldg. B  
Far East International Plaza  
No. 317 Xian Xia Road  
Shanghai, 200051  
Tel: 86-21-6275-5700 Fax: 86-21-6275-5060

#### China - Shenzhen

Microchip Technology Consulting (Shanghai)  
Co., Ltd., Shenzhen Liaison Office  
Rm. 1315, 13/F, Shenzhen Kerry Centre,  
Renminnan Lu  
Shenzhen 518001, China  
Tel: 86-755-2350361 Fax: 86-755-2366086

#### China - Hong Kong SAR

Microchip Technology Hongkong Ltd.  
Unit 901-6, Tower 2, Metroplaza  
223 Hing Fong Road  
Kwai Fong, N.T., Hong Kong  
Tel: 852-2401-1200 Fax: 852-2401-3431

#### India

Microchip Technology Inc.  
India Liaison Office  
Divyasree Chambers  
1 Floor, Wing A (A3/A4)  
No. 11, O'Shaugnessey Road  
Bangalore, 560 025, India  
Tel: 91-80-2290061 Fax: 91-80-2290062

### Japan

Microchip Technology Japan K.K.  
Benex S-1 6F  
3-18-20, Shinyokohama  
Kohoku-Ku, Yokohama-shi  
Kanagawa, 222-0033, Japan  
Tel: 81-45-471-6166 Fax: 81-45-471-6122

### Korea

Microchip Technology Korea  
168-1, Youngbo Bldg. 3 Floor  
Samsung-Dong, Kangnam-Ku  
Seoul, Korea 135-882  
Tel: 82-2-554-7200 Fax: 82-2-558-5934

### Singapore

Microchip Technology Singapore Pte Ltd.  
200 Middle Road  
#07-02 Prime Centre  
Singapore, 188980  
Tel: 65-6334-8870 Fax: 65-6334-8850

### Taiwan

Microchip Technology Taiwan  
11F-3, No. 207  
Tung Hua North Road  
Taipei, 105, Taiwan  
Tel: 886-2-2717-7175 Fax: 886-2-2545-0139

### EUROPE

#### Denmark

Microchip Technology Nordic ApS  
Regus Business Centre  
Lautrup høj 1-3  
Ballerup DK-2750 Denmark  
Tel: 45 4420 9895 Fax: 45 4420 9910

#### France

Microchip Technology SARL  
Parc d'Activite du Moulin de Massy  
43 Rue du Saule Trapu  
Batiment A - 1er Etage  
91300 Massy, France  
Tel: 33-1-69-53-63-20 Fax: 33-1-69-30-90-79

#### Germany

Microchip Technology GmbH  
Gustav-Heinemann Ring 125  
D-81739 Munich, Germany  
Tel: 49-89-627-144 0 Fax: 49-89-627-144-44

#### Italy

Microchip Technology SRL  
Centro Direzionale Colleoni  
Palazzo Taurus 1 V. Le Colleoni 1  
20041 Agrate Brianza  
Milan, Italy  
Tel: 39-039-65791-1 Fax: 39-039-6899883

#### United Kingdom

Microchip Ltd.  
505 Eskdale Road  
Winnersh Triangle  
Wokingham  
Berkshire, England RG41 5TU  
Tel: 44 118 921 5869 Fax: 44-118 921-5820

05/01/02