

FEATURES

- Silicon epitaxial planar diode
- Fast switching diode
- 500mW power dissipation
- This diode is also available in other case styles including: the DO-35 case with the type designation 1N4148, the MiniMelf case with the type designation LL4148, the MicroMelf case with the type designation MCL4148, the SOD-323 case with the type designation 1N4148WS, the SOD-523 case with the type designation 1N4148WT.

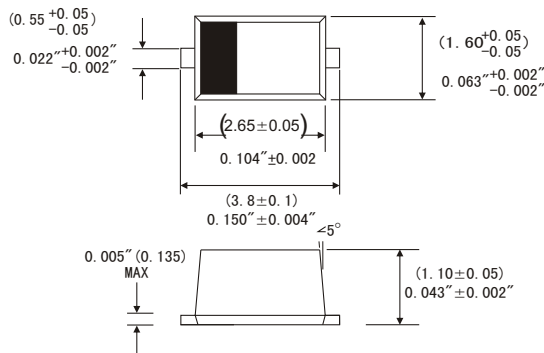

SOD-123



Dimensions in inches and (millimeters)

MECHANICAL DATA

- Case: SOD-123 plastic case
- Weight: Approx. 0.01 gram

MAXIMUM RATINGS AND ELECTRICAL CHARACTERISTICS

(Ratings at 25°C ambient temperature unless otherwise specified)

	Symbols	Value	Units
DC Blocking Voltage	V_R	75	Volts
Non-Repetitive Peak Reverse Voltage	V_{RM}	100	Volts
Average rectified current, Half wave rectification with Resistive load at $T_A=25^\circ\text{C}$ and $f \geq 50\text{Hz}$	I_{AV}	150	mA
Non-Repetitive Peak Forward Surge Current @ $t=1.0\text{s}$	I_{FSM}	500	mA
Power dissipation at $T_A=25^\circ\text{C}$	P_{tot}	400	mW
Junction temperature	T_J	150	°C
Storage temperature range	T_{STG}	-65 to +150	°C

ELECTRICAL CHARACTERISTICS

(Ratings at 25°C ambient temperature unless otherwise specified)

	Symbol	Min.	Typ.	Max.	Units
Forward voltage at $I_F=10\text{mA}$	V_F			1	Volts
Leakage current at $V_R=20\text{V}$ at $V_R=75\text{V}$ at $V_R=20\text{V}$, $T_J=150^\circ\text{C}$	I_R			25	nA
	I_R			5	μA
	I_R			50	μA
Junction capacitance at $V_R=V_F=0\text{V}$	C_J			4	pF
Voltage rise when switching on tested with 50mA pulse $t_p=0.1\mu\text{s}$, Rise time $<30\mu\text{s}$, $f_p=5$ to 100kHz	V_{fr}			2.5	Volts
Reverse recovery time from $I_F=10\text{mA}$ to $I_R=1\text{mA}$, $V_R=6\text{V}$, $R_L=100\Omega$	t_{rr}			4	ns
Thermal resistance junction to ambient	$R_{\theta JA}$		312		K/W
Rectification efficiency at $f=100\text{MHz}$, $V_{RF}=2\text{V}$	η	0.45			

RATINGS AND CHARACTERISTIC CURVES 1N4148W

FIG 1-FORWARD CHARACTERISTICS

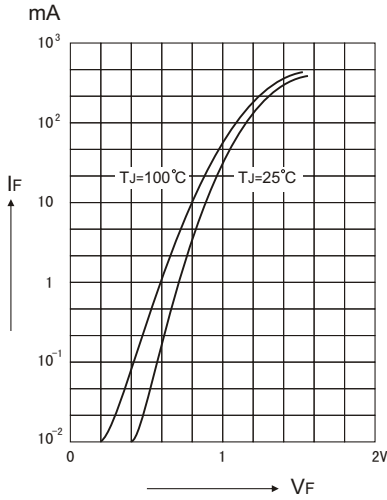

FIG 2: DYNAMIC FORWARD RESISTANCE VERSUS FORWARD CURRENT

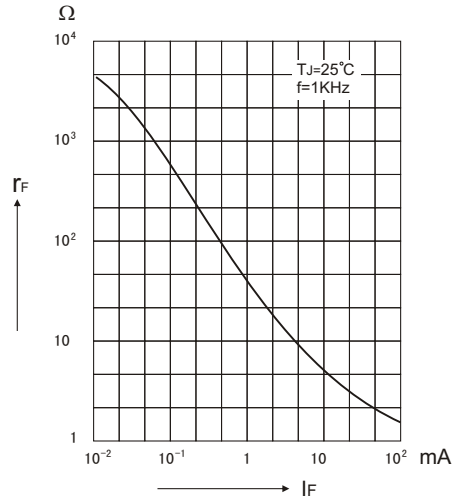

FIG 3-ADMISSIBLE POWER DISSIPATION VERSUS AMBIENT TEMPERATURE

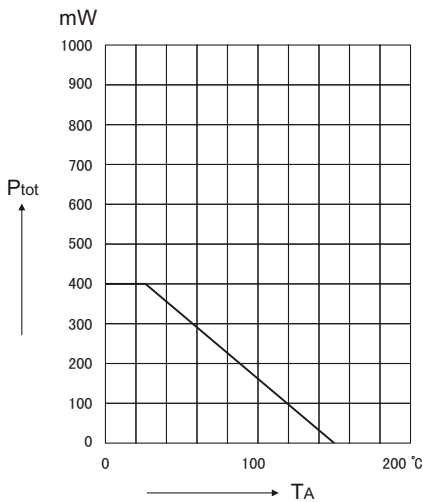
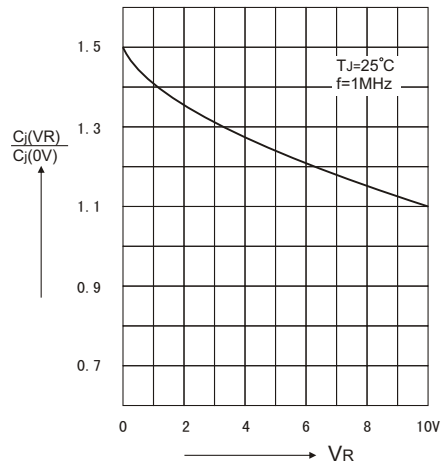

FIG. 4-RELATIVE CAPACITANCE VERSUS VOLTAGE



RATINGS AND CHARACTERISTIC CURVES 1N4148W

FIG.5 RECTIFICATION EFFICIENCY MEASUREMENT CIRCUIT

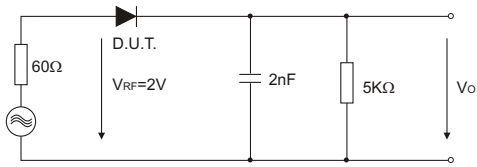

FIG 6: LEAKAGE CURRENT VERSUS JUNCTION TEMPERATURE

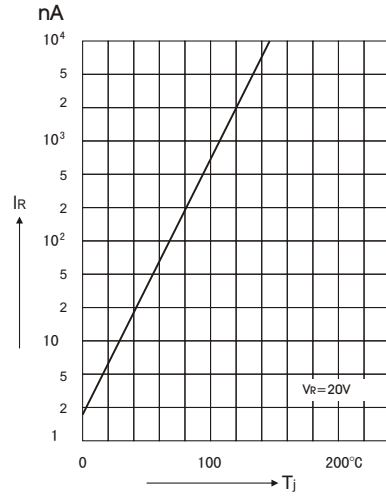

FIG 7: ADMISSIBLE REPETITIVE PEAK FORWARD CURRENT VERSUS PULSE DURATION

