

isc N-Channel MOSFET Transistor

1N50A

• FEATURES

- Drain Current  $I_D = 1.2A @ T_C = 25^\circ C$
- Drain Source Voltage-  
:  $V_{DSS} = 500V(\text{Min})$
- Static Drain-Source On-Resistance  
:  $R_{DS(on)} = 5.5 \Omega (\text{Max})$
- Fast Switching

• APPLICATIONS

- Switch mode power supply.

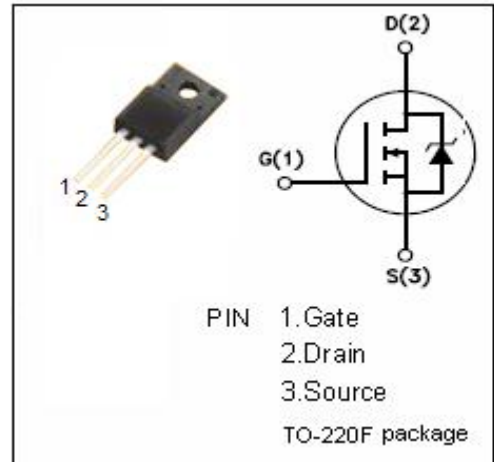

• ABSOLUTE MAXIMUM RATINGS( $T_a = 25^\circ C$ )

SYMBOL	PARAMETER	VALUE	UNIT
$V_{DSS}$	Drain-Source Voltage	500	V
$V_{GS}$	Gate-Source Voltage-Continuous	$\pm 30$	V
$I_D$	Drain Current-Continuous	1.2	A
$I_{DM}$	Drain Current-Single Plused	5	A
$P_D$	Total Dissipation @ $T_C = 25^\circ C$	36	W
$T_j$	Max. Operating Junction Temperature	150	$^\circ C$
$T_{stg}$	Storage Temperature	-55~150	$^\circ C$

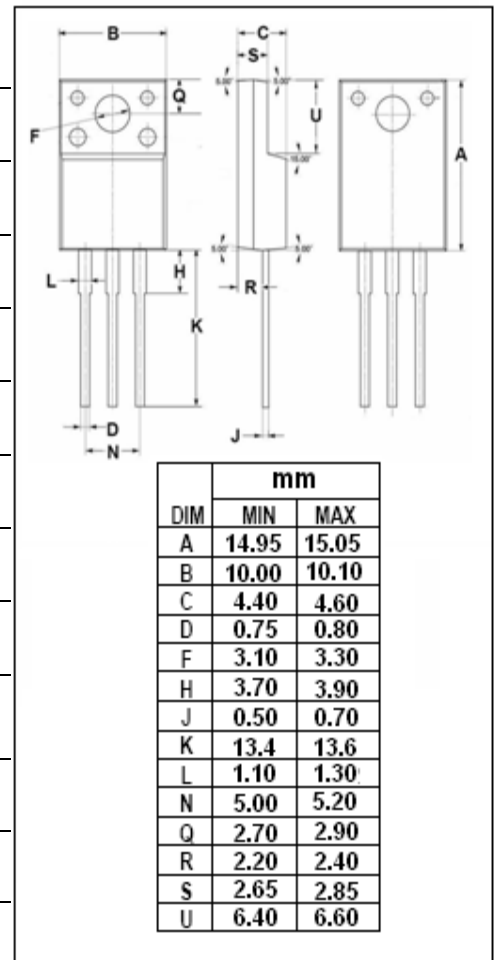

• THERMAL CHARACTERISTICS

SYMBOL	PARAMETER	MAX	UNIT
$R_{th j-c}$	Thermal Resistance, Junction to Case	3.44	$^\circ C/W$

**isc N-Channel MOSFET Transistor****1N50A****• ELECTRICAL CHARACTERISTICS** $T_C=25^{\circ}\text{C}$  unless otherwise specified

SYMBOL	PARAMETER	CONDITIONS	MIN	TYPE	MAX	UNIT
$V_{(BR)DSS}$	Drain-Source Breakdown Voltage	$V_{GS}=0; I_D=250\mu\text{A}$	500			V
$V_{GS(th)}$	Gate Threshold Voltage	$V_{DS}=V_{GS}; I_D=250\mu\text{A}$	2.0		4.0	V
$V_{SD}$	Diode Forward On-voltage	$I_S=1.2\text{A}; V_{GS}=0$			1.5	V
$R_{DS(on)}$	Drain-Source On-Resistance	$V_{GS}=10\text{V}; I_D=0.6\text{A}$			5.5	$\Omega$
$I_{GSS}$	Gate-Body Leakage Current	$V_{GS}=\pm 30\text{V}; V_{DS}=0$			$\pm 100$	nA
$I_{DSS}$	Zero Gate Voltage Drain Current	$V_{DS}=500\text{V}; V_{GS}=0$			10	$\mu\text{A}$
$C_{iss}$	Input Capacitance	$V_{DS}=25\text{V};$ $V_{GS}=0\text{V};$ $f_T=1\text{MHz}$		220	290	pF
$C_{rss}$	Reverse Transfer capacitance			11	13	
$C_{oss}$	Output Capacitance			30	35	
$t_r$	Rise Time	$V_{GS}=10\text{V};$ $I_D=1.2\text{A};$ $V_{DD}=250\text{V};$ $R_L=24\Omega$		13	35	ns
$t_{d(on)}$	Turn-on Delay Time			12	35	
$t_f$	Fall Time			15	40	
$t_{d(off)}$	Turn-off Delay Time			42	90	