

isc Silicon PNP Power Transistor

2SB1155

DESCRIPTION

- Collector-Emitter Breakdown Voltage-  
:  $V_{(BR)CEO} = -80V(\text{Min})$
- Good Linearity of  $h_{FE}$
- Low Collector Saturation Voltage-  
:  $V_{CE(sat)} = -0.5V(\text{Max.}) @ I_C = -7A$
- Complement to Type 2SD1706

APPLICATIONS

- Designed for power switching applications

ABSOLUTE MAXIMUM RATINGS( $T_a=25^\circ\text{C}$ )

SYMBOL	PARAMETER	VALUE	UNIT
$V_{CBO}$	Collector-Base Voltage	-130	V
$V_{CEO}$	Collector-Emitter Voltage	-80	V
$V_{EBO}$	Emitter-Base Voltage	-7	V
$I_C$	Collector Current-Continuous	-15	A
$I_{CP}$	Collector Current-Pulse	-25	A
$P_C$	Collector Power Dissipation @ $T_C=25^\circ\text{C}$	80	W
	Collector Power Dissipation @ $T_a=25^\circ\text{C}$	3	
$T_J$	Junction Temperature	150	$^\circ\text{C}$
$T_{stg}$	Storage Temperature Range	-55~150	$^\circ\text{C}$

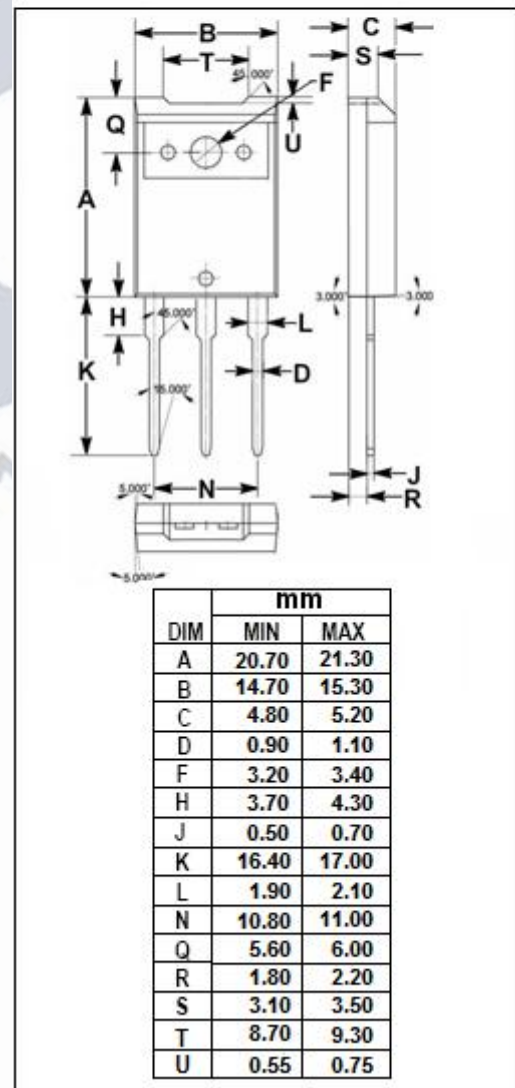
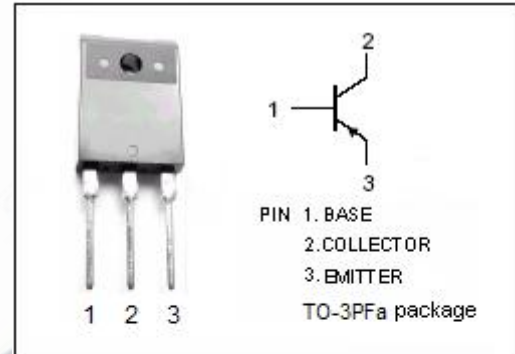

## isc Silicon PNP Power Transistor

## 2SB1155

## ELECTRICAL CHARACTERISTICS

 $T_C=25^\circ\text{C}$  unless otherwise specified

SYMBOL	PARAMETER	CONDITIONS	MIN	TYP.	MAX	UNIT
$V_{(BR)CEO}$	Collector-Emitter Breakdown Voltage	$I_C = -10\text{mA}; I_B = 0$	-80			V
$V_{CE(sat)-1}$	Collector-Emitter Saturation Voltage	$I_C = -7\text{A}; I_B = -0.35\text{A}$			-0.5	V
$V_{CE(sat)-2}$	Collector-Emitter Saturation Voltage	$I_C = -15\text{A}; I_B = -1.5\text{A}$			-1.5	V
$V_{BE(sat)-1}$	Base -Emitter Saturation Voltage	$I_C = -7\text{A}; I_B = -0.35\text{A}$			-1.5	V
$V_{BE(sat)-2}$	Base -Emitter Saturation Voltage	$I_C = -15\text{A}; I_B = -1.5\text{A}$			-2.5	V
$I_{CBO}$	Collector Cutoff Current	$V_{CB} = -100\text{V}; I_E = 0$			-10	$\mu\text{A}$
$I_{EBO}$	Emitter Cutoff Current	$V_{EB} = -5\text{V}; I_C = 0$			-50	$\mu\text{A}$
$h_{FE-1}$	DC Current Gain	$I_C = -0.1\text{A}; V_{CE} = -2\text{V}$	45			
$h_{FE-2}$	DC Current Gain	$I_C = -3\text{A}; V_{CE} = -2\text{V}$	90		260	
$h_{FE-3}$	DC Current Gain	$I_C = -8\text{A}; V_{CE} = -2\text{V}$	30			
$f_T$	Current-Gain—Bandwidth Product	$I_C = -0.5\text{A}; V_{CE} = -10\text{V}$		25		MHz

## Switching Times

$t_{on}$	Turn-on Time	$I_C = -7\text{A}, I_{B1} = -I_{B2} = -0.7\text{A}; V_{CC} = -50\text{V}$		0.5		$\mu\text{s}$
$t_{stg}$	Storage Time			1.3		$\mu\text{s}$
$t_f$	Fall Time			0.2		$\mu\text{s}$

◆  $h_{FE-2}$  Classifications

Q	P
90-180	130-260