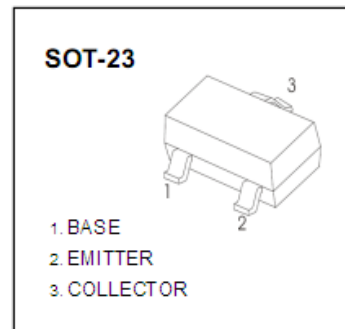

**2SC2412 (NPN)****特点/Features :**输出电容 (C_{OB}) 低 , 典型值 2.0pF;**用途/Applications :**

用于一般放大。

**极限参数/Absolute maximum ratings($T_a=25^{\circ}\text{C}$)**

参数/Parameter	符号/ Symbol	数值/Value	单位/Unit
集电极-基极电压/Collector-Base Voltage	V_{CB0}	60	V
集电极-发射极电压/Collector-Emitter Voltage	V_{CE0}	50	V
发射极-基极电压/Emitter-Base Voltage	V_{EB0}	7	V
集电极连续电流/Collector Current Continuous	I_C	0.15	A
集电极耗散功率/Collector Power Dissipation	P_C	0.2	W
结温/Junction Temperature	T_j	150	$^{\circ}\text{C}$
储存温度/Storage Temperature	T_{stg}	-55~150	$^{\circ}\text{C}$

电性能参数/Electrical characteristics ($T_a=25^{\circ}\text{C}$)

参数	符号	测试条件	最小值	典型值	最大值	单位
集电极-基极击穿电压	$V_{BR(CB0)}$	$I_C=50\mu\text{A}, I_E=0$	60			V
集电极-发射极击穿电压	$V_{BR(CE0)}$	$I_C=1\text{mA}, I_B=0$	50			V
发射极-基极击穿电压	$V_{BR(EB0)}$	$I_E=50\mu\text{A}, I_C=0$	7			V
集电极截止电流	I_{CB0}	$V_{CB}=60\text{V}, I_E=0$			0.1	μA
发射极截止电流	I_{EB0}	$V_{EB}=7\text{V}, I_C=0$			0.1	μA
直流电流增益	h_{FE}	$V_{CE}=6\text{V}, I_C=1\text{mA}$	120		560	
集电极-发射极饱和压降	$V_{CE(sat)}$	$I_C=50\text{mA}, I_B=5\text{mA}$			0.4	V
基极-发射极饱和压降	$V_{BE(sat)}$	$I_C=100\text{mA}, I_B=10\text{mA}$			1	V
特征频率	f_T	$V_{CE}=12\text{V}, I_C=2\text{mA}, f=100\text{MHz}$		160		MHz
输出电容	C_{ob}	$V_{CB}=12\text{V}, I_E=0, f=1\text{MHz}$		2.0	3.5	pF

Marking And h_{FE} 分档/Classification of h_{FE}

档位/Rank	Q	R	S
范围/Range	120~270	180~390	270~560
Marking	BQ	BR	BS



典型特性曲线图/Typical Characteristics

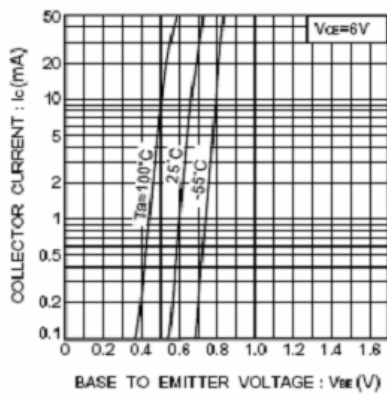

Fig.1 Grounded emitter propagation characteristics

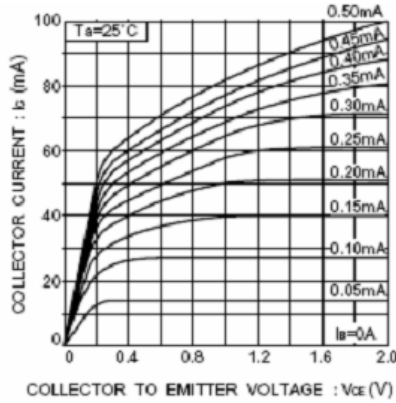

Fig.2 Grounded emitter output characteristics (I)

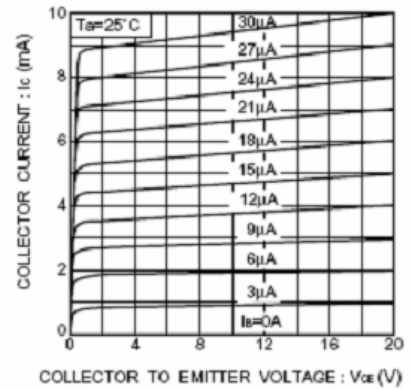

Fig.3 Grounded emitter output characteristics (II)

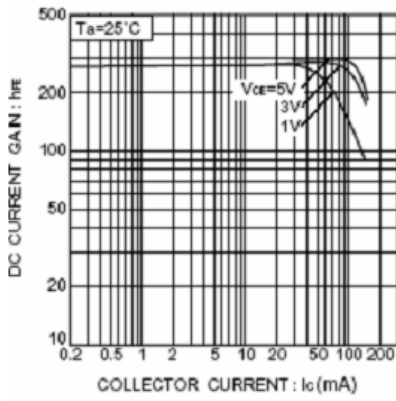

Fig.4 DC current gain vs. collector current (I)

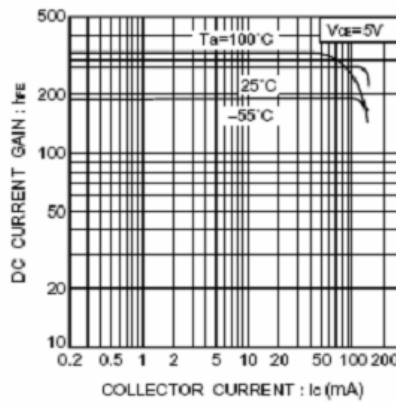

Fig.5 DC current gain vs. collector current (II)

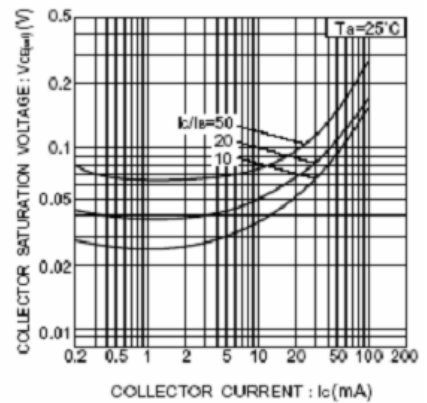

Fig.6 Collector-emitter saturation voltage vs. collector current

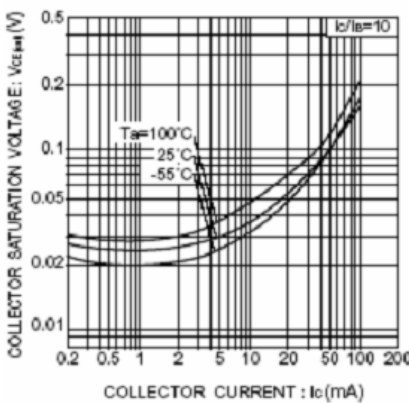

Fig.7 Collector-emitter saturation voltage vs. collector current (I)

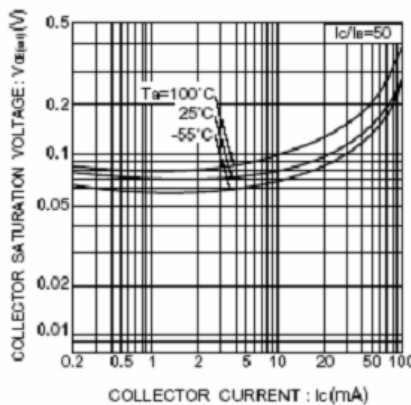

Fig.8 Collector-emitter saturation voltage vs. collector current (II)

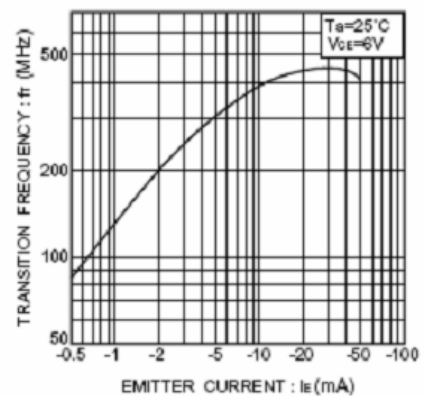

Fig.9 Gain bandwidth product vs. emitter current



SOT-23 封装半导体晶体管/SOT-23 Plastic-Encapsulate Transistors

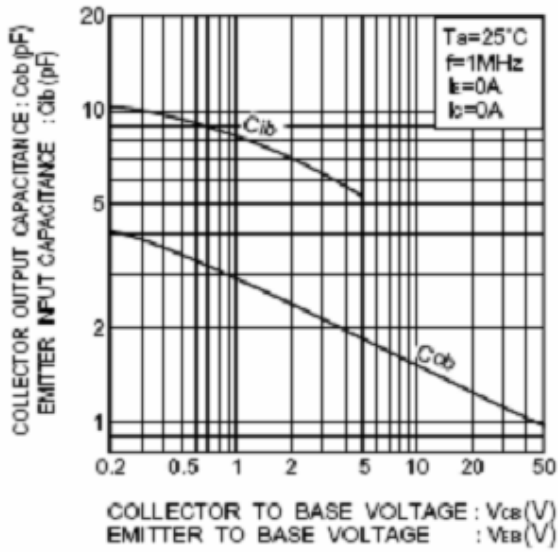

Fig.10 Collector output capacitance vs. collector-base voltage
Emitter input capacitance vs. emitter-base voltage

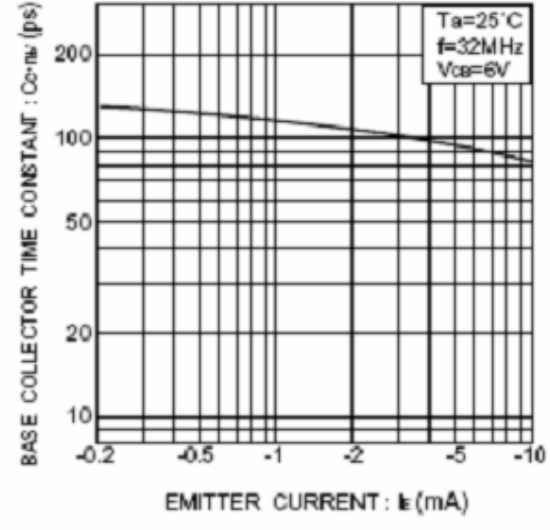

Fig.11 Base-collector time constant vs. emitter current