

isc Silicon NPN Darlington Power Transistor

2SD1522

DESCRIPTION

- Collector-Emitter Breakdown Voltage-  
:  $V_{(BR)CEO} = 450V(\text{Min})$
- High DC Current Gain  
:  $h_{FE} = 500(\text{Min}) @ I_C = 5A, V_{CE} = 3V$
- Fast Switching Speed
- Minimum Lot-to-Lot variations for robust device performance and reliable operation

APPLICATIONS

- Designed for audio frequency power amplifier and low speed high current switching industrial applications.

ABSOLUTE MAXIMUM RATINGS( $T_a=25^\circ\text{C}$ )

SYMBOL	PARAMETER	VALUE	UNIT
$V_{CBO}$	Collector-Base Voltage	500	V
$V_{CEO}$	Collector-Emitter Voltage	450	V
$V_{EBO}$	Emitter-Base Voltage	7	V
$I_C$	Collector Current-Continuous	10	A
$I_{CM}$	Collector Current-Peak	20	A
$P_C$	Collector Power Dissipation @ $T_a=25^\circ\text{C}$	3	W
	Collector Power Dissipation @ $T_C=25^\circ\text{C}$	100	
$T_j$	Junction Temperature	150	$^\circ\text{C}$
$T_{stg}$	Storage Temperature Range	-55~150	$^\circ\text{C}$

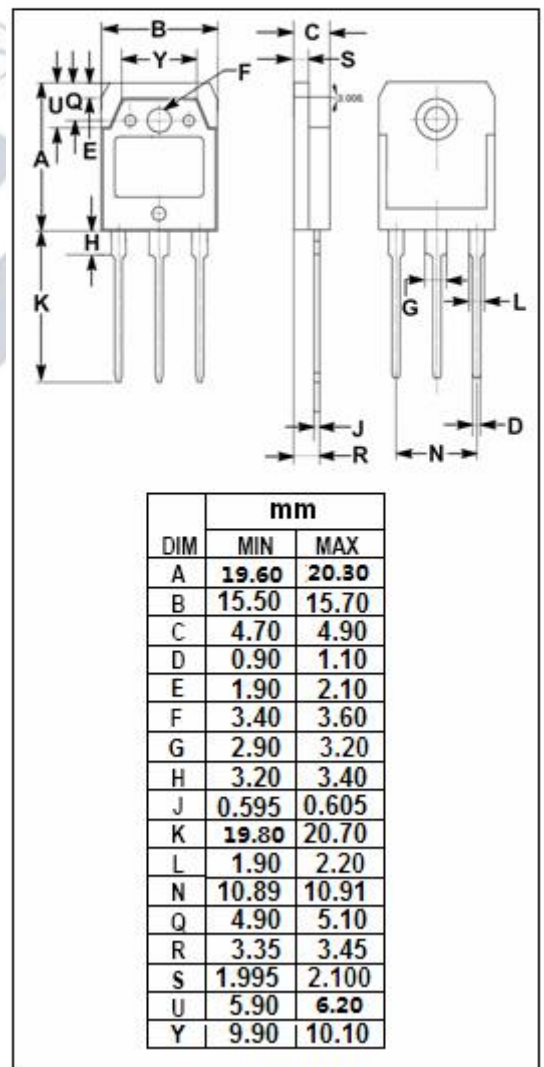
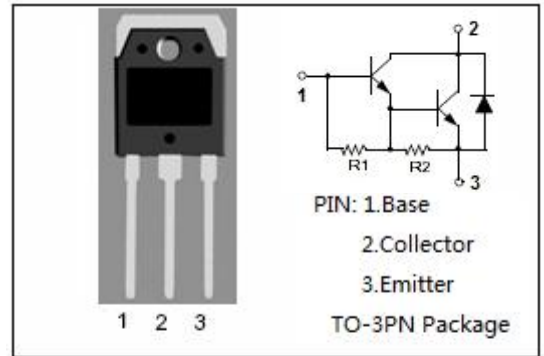

**isc Silicon NPN Darlington Power Transistor****2SD1522****ELECTRICAL CHARACTERISTICS****T<sub>c</sub>=25°C unless otherwise specified**

SYMBOL	PARAMETER	CONDITIONS	MIN	TYP.	MAX	UNIT
V <sub>(BR)CEO</sub>	Collector-Emitter Breakdown Voltage	I <sub>C</sub> = 30mA, I <sub>B</sub> = 0	450			V
V <sub>(BR)EBO</sub>	Emitter-Base Breakdown Voltage	I <sub>E</sub> = 20mA, I <sub>C</sub> = 0	7			V
V <sub>CE(sat)</sub>	Collector-Emitter Saturation Voltage	I <sub>C</sub> = 5A, I <sub>B</sub> = 8mA			1.5	V
V <sub>BE(sat)</sub>	Base-Emitter Saturation Voltage	I <sub>C</sub> = 5A, I <sub>B</sub> = 8mA			2.0	V
I <sub>CBO</sub>	Collector Cutoff current	V <sub>CB</sub> = 500V, I <sub>E</sub> = 0			0.1	mA
I <sub>EBO</sub>	Emitter Cutoff Current	V <sub>EB</sub> = 7V; I <sub>C</sub> = 0			20	mA
h <sub>FE</sub>	DC Current Gain	I <sub>C</sub> = 5A; V <sub>CE</sub> = 3V	500			

## Switching Times

t <sub>on</sub>	Turn-On Time	I <sub>C</sub> = 5A, I <sub>B1</sub> = I <sub>B2</sub> = 8mA		1.5		μ s
t <sub>stg</sub>	Storage Time			7.0		μ s
t <sub>f</sub>	Fall Time			4.0		μ s