

TNT4882

Single-Chip IEEE 488.2 Talker/Listener ASIC

Features

100-pin plastic quad flat pack (QFP), surface-mount package

IEEE 488.1-compatible transceivers on chip

Fast data transfers

- Up to 1.5 Mbytes/s using interlocked IEEE 488.1 handshake
- Up to 8 Mbytes/s using HS488™

Two 8-bit 16-deep FIFOs buffer data between GPIB and CPU

With exception of Controller, performs all IEEE 488 interface functions

- SH1, AH1, T5 or TE5, L3 or LE3, SR1, RL1, PP1 or PP2, DC1, DT1, and CO

Meets all IEEE 488.2 requirements

- Bus line monitoring
- Preferred implementation of requesting service
- Not sending messages when there are no Listeners

Software compatible with Turbo488™/NAT4882™ ASICs

Reduces software overhead

- Does not lose a data byte if ATN is asserted while transmitting data
- Static interrupts status bits that do not clear when read

- Automatically transmits END or performs RFD holdoff on last byte of DMA transfer

- Interrupts when handshake is complete on last byte of a DMA transfer

- Has 32-bit counter for large, uninterrupted data transfers

Programmable timer interrupt for general-purpose timing use

Complete in-system functional testing with internal loop-back mode

ISA bus glue logic on chip

Direct memory access (DMA)

Device status indicator pins

- My Address, Talk Addressed, Listen Addressed, REM, DCAS, TRIG

Automatically processes IEEE 488 commands and reads undefined commands

Handles 6 primary and secondary addressing modes

Automatic EOS and/or NL message detection

Programmable data transfer rate - TTL-compatible CMOS device

NEW!



Description

The TNT4882 provides a single-chip IEEE 488.2 Talker/Listener interface to the general-purpose interface bus (GPIB). The TNT4882 combines the circuitry of the NAT4882 IEEE 488.2 application-specific integrated circuit (ASIC), Turbo488 performance-enhancing ASIC, and GPIB transceivers to create a single-chip IEEE 488.2 interface. Because the TNT4882 contains the NAT4882 register set, which in turn has the NEC μ PD7210 and TI TMS 9914A register sets, developers using any of these chips can easily port existing code directly to the TNT4882, thereby significantly reducing software development time. Also, with just a few modifications, you can implement all the improved features of the IEEE 488.2 standard. The TNT4882 is ideal for use in all IEEE 488 instrument designs because of its small size, surface-mount ability, and performance enhancements that include HS488, a new high-speed mode for GPIB transfers.

HS488 Overview

The HS488 high-speed mode for GPIB transfers increases the maximum data transfer rate of devices on a GPIB network up to 8 Mbytes/s. The TNT4882 completely and transparently handles the HS488 protocol without additional circuitry, a method that is a superset of the IEEE 488 standard. Thus, you can mix existing GPIB devices with HS488 devices without changing your application programs. The TNT4882 can implement high-speed data transfers automatically. Maximum data transfer rates obtainable using HS488 depend on the host architecture and system configuration.

Architecture, Modes

The TNT4882 integrates the circuitry of the Turbo488, NAT4882, and IEEE 488.1-compatible transceivers. The TNT4882 circuitry logically interconnects these three components in one of two ways - "one-chip mode" (see Figure 1) or "two-chip mode" (see Figure 2).

The TNT4882 powers up in two-chip mode, which exactly duplicates the Turbo488/NAT4882 chipset for software compatibility. During I/O accesses in two-chip mode, the CPU accesses the Turbo488 and passes all accesses within a certain address range to the NAT4882. The Turbo488 also manages transfers between its internal first-in first-out buffers (FIFOs) and the NAT4882, arbitrating between these data transfers and any I/O accesses of the NAT4882 by the CPU. Accesses to the NAT4882 registers take longer than Turbo488 accesses because all accesses to the NAT4882 registers must go through the Turbo488 and its arbiter.

To achieve higher data transfer rates, you can switch the TNT4882 to one-chip mode in software. In one-chip mode, the first-in first-out (FIFO) buffer connects directly to the GPIB transceivers and the CPU accesses all registers directly. You can access NAT4882 registers in the same amount of time as Turbo488 registers because accesses to these registers do not go through the Turbo488.

The NAT4882 portion of the TNT4882 can emulate either the NEC μ PD7210 or the TI TMS9914A GPIB controller chips. The state of one of the TNT4882 input pins determines the chip emulation mode on power up, but you can switch the chip emulation mode back and forth between 7210 and 9914 modes through software.

TNT4882

Single-Chip IEEE 488.2 Talker/Listener ASIC

The register map of the NAT4882 portion of the TNT4882 changes to emulate either the 7210 or the 9914, but the Turbo488 registers are identical in both chip emulation modes. You cannot use one-chip mode with the 9914 emulation mode. Because the Turbo488 was designed to interface to the 7210 and not the 9914, the software can rearrange the register map of the 9914 mode NAT4882 registers so that the 9914 mode Command/Data Out Register and Data In Register and the Auxiliary Command Register appear at the same addresses as the corresponding 7210 mode registers. The Turbo488 can then perform DMA transfers with the NAT4882 in 9914 mode.

The TNT4882 has two different pin configurations – Generic (see Figure 3) and ISA (see Figure 4). The TNT4882 determines which configuration to use by the location of the power (VDD) and ground pins. The Generic pin configuration provides a simple interface to any CPU. Using the ISA pin configuration, you can connect the TNT4882 directly to an ISA (IBM PC AT) bus without any external glue logic or data transceivers. You can also use the ISA pin configuration TNT4882 with an 8-bit (PC/XT) bus. You may want to use the ISA version for interfaces other than an ISA bus to take advantage of the built-in 5-bit address decoder. You can use two-chip mode, one-chip mode, 7210 mode, and 9914 mode identically with either pin configuration.

TNT4882 Block Diagrams

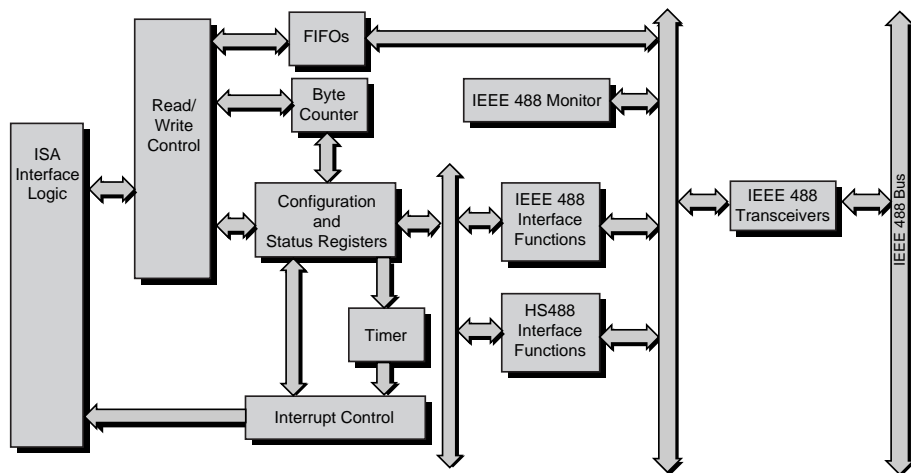

Figure 1. TNT4882 One-Chip Mode

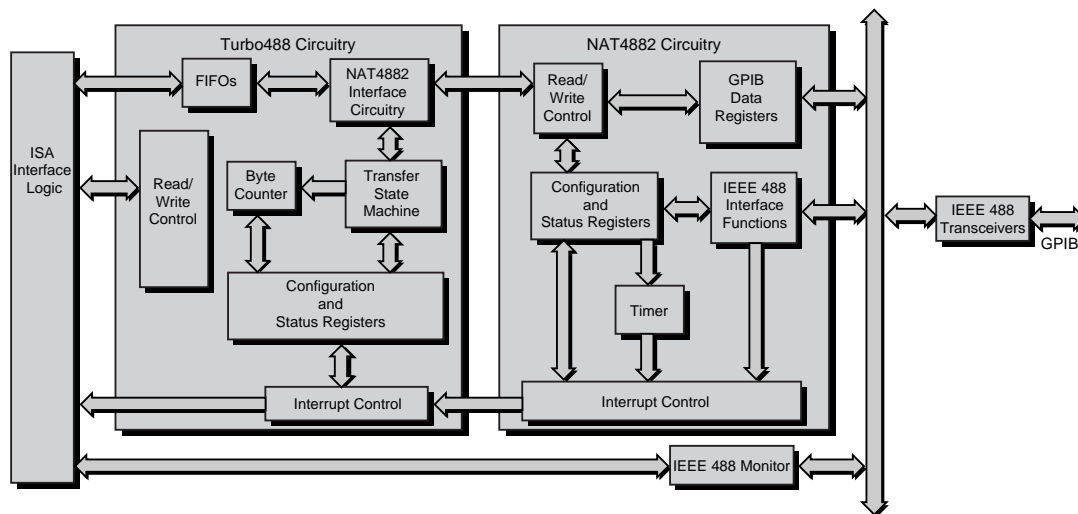

Figure 2. TNT4882 Two-Chip Mode

TNT4882

Single-Chip IEEE 488.2 Talker/Listener ASIC

Generic Pin Configuration

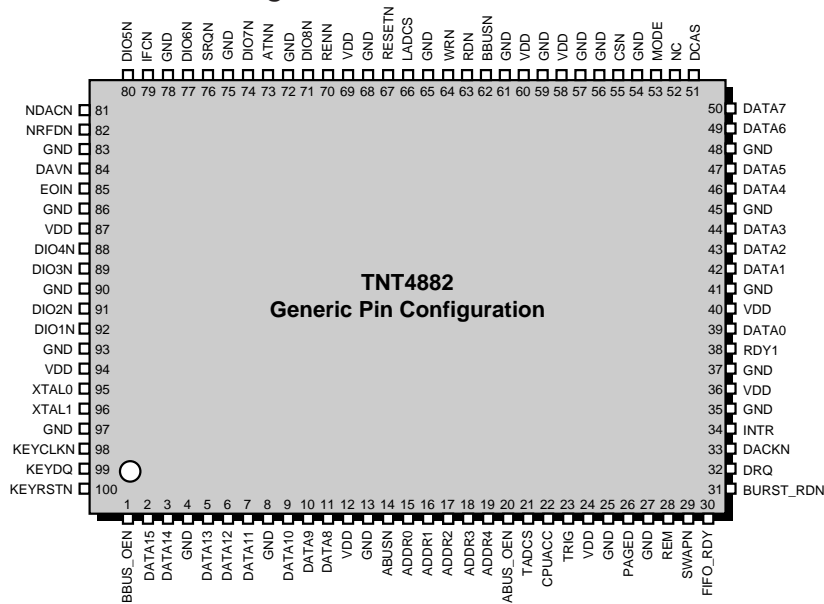

Figure 3. TNT4882 Generic Pin Configuration

Generic Pin Description

All pins with names that end in 'N' are active low; all others are active high. All input (I) and bidirectional (I/O) pins have an internal pull-up resistor between 50 kΩ and 150 kΩ.

Note: You can also see the "Hardware Considerations" chapter of the "TNT Programmer Reference Manual" (P/N 320724-01) for more information.

Pin No.(s)	Name(s)	Type	Description
1	BBUS_OEN	O	Asserts when DATA7-0 (B bus) is enabled for output
2,3,5,6,7,9,10,11	DATA15-8	I/O	Upper 8 bits of bidirectional three-state data bus for transfer of commands, data, and status between TNT4882 and CPU – also known as the A bus
14	ABUSN	I	Enables register accesses through the A bus (DATA15-8) – DATA15 is the most significant bit
19-15	ADDR4-0	I	Determines which register to access during a read or write operation
20	ABUS_OEN	O	Asserts when DATA15-8 (A bus) is enabled for output
21	TADCS	O	Asserts when the TNT4882 is an active or addressed IEEE 488 Talker (TADS, TACS, or SPAS)
22	CPUACC	O	Asserts when in two-chip mode during a NAT4882 register I/O access
23	TRIG	O	Asserts when in DTAS or when the auxiliary trigger software command is issued
26	PAGED	I	Asserting this pin pages in the page-in registers in the 7210 mode
28	REM	O	Asserts when the TNT4882 is in a remote state (REMS or RWLS)
29	SWAPN	I	Rearranges the order of the registers when asserted and in 9914 mode
30	FIFO_RDY	O	Asserts when the FIFO is ready for burst access
31	BURST_RDN	I	When asserted, places the TNT4882 in a burst read mode, in which the first word in the FIFO is always driven on the TNT4882 data bus – words are removed from the FIFOs at each rising edge of RDN – see reference manual for details
32	DRQ	O	Asserts to request a DMA transfer cycle
33	DACKN	I	Enables FIFO accesses during a DMA transfer cycle
34	INTR	O	Asserts when one or more of the unmasked interrupt conditions becomes true
38	RDY1	O	Asserts during an I/O access to indicate that the read data is available or that the write data has been latched – asserts immediately on an access to Turbo488 registers or in one-chip mode
50,49,47,46, 44,43,42,39	DATA7-0	I/O	Lower eight bits of bidirectional three-state data bus for transfer of commands, data, and status between TNT4882 and CPU – also known as the B bus – DATA7 is the most significant bit

Table continued on page 4

TNT4882

Single-Chip IEEE 488.2 Talker/Listener ASIC

Table continued from page 3

Pin No.(s)	Name(s)	Type	Description
51	DCAS	O	Asserts when the device clear state machine is in DCAS
52	NC	O	Leave this pin unconnected
53	MODE	I	Determines whether the TNT4882 powers up in 7210 or 9914 emulation mode – High = 7210 mode, Low = 9914 mode
55	CSN	I	Chip Select enables I/O transfers between the CPU and the TNT4882
62	BBUSN	I	Enables register accesses through the B bus (DATA7-0)
63	RDN	I	Enables the contents of the registers selected by ADDR 4:0 and CSN or the FIFOs to appear on the data bus selected by ABUSN and BBUSN
64	WRN	I	Latches data on the bus selected by ABUSN and BBUSN into an internal TNT4882 register on the trailing (rising) edge of WRN
66	LADCS	O	Asserts when the TNT4882 is addressed as a Listener
67	RESETN	I	Holds the TNT4882 in its idle state
71,74,77,80,88, 89,91,92	DIO8-1N	I/O	8-bit bidirectional IEEE 488 data bus
70,73,76,79, 81,82,84,85	RENN, ATNN, SRQN, IFCN, NDACN, NRFDN, DAVN, EOIN	I/O	IEEE 488 control signals
95	XTAL0	O	Output of crystal circuit – use only for driving a quartz crystal
96	XTAL1	I	Crystal oscillator input – drive with a 40 MHz CMOS input level clock signal
98	KEYCLKN	O	Strobes data to or from a DS1204 electronic key
99	KEYDQ	I/O	Transmits serial data between the TNT4882 and a DS1204 key
100	KEYRSTN	O	Resets a DS1204 key
4,8,13,25,27,35,37 41,45,48,54,56,57, 59,61,65,68,72,75, 78,83,86,90,93,97	GND	–	Ground pins – 0 V
12,24,36,40,58, 60,69,87,94	VDD	–	Power pins – +5 V (±5%)

ISA Pin Configuration

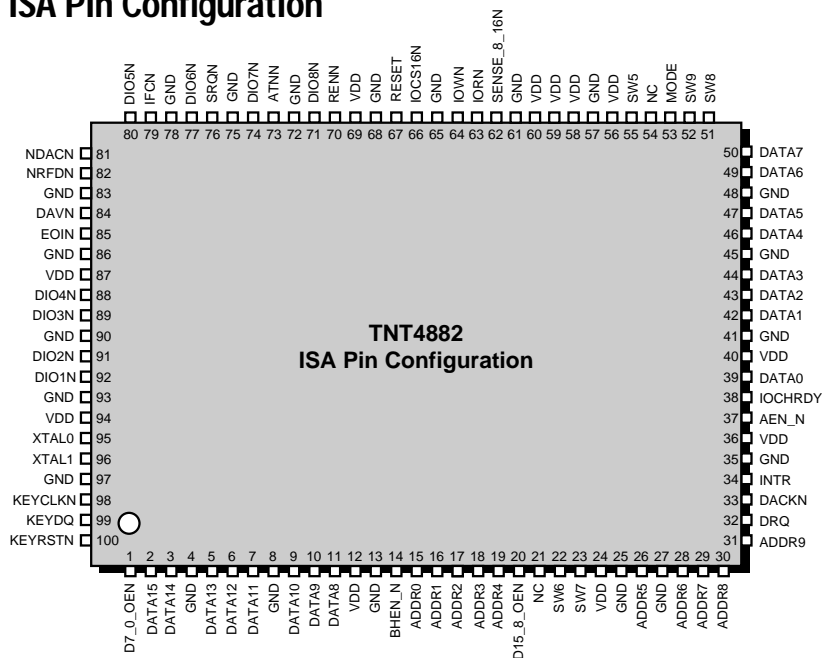

Figure 4. TNT4882 ISA Pin Configuration

TNT4882

Single-Chip IEEE 488.2 Talker/Listener ASIC

ISA Pin Description

All input (I) and bidirectional (I/O) pins have an internal pull-up resistor between 50 k Ω and 150 k Ω . Pins with names that end in "N" are active low signals – all others are active high. Open-collector outputs are type "OC."

Note: You can also see the "Hardware Considerations" chapter of the "TNT Programmer Reference Manual" (P/N 320724-01) for more information.

Pin No. (s)	Name(s)	Type	Description
1	D7_0_OEN	O	Asserts when DATA7-0 bus is enabled for output – may be left unconnected
2,3,5,6,7,9,10,11	DATA15-8	I/O	Upper eight bits of bidirectional three-state data bus for transfer of commands, data, and status between TNT4882 and CPU – can connect directly to the AT bus – DATA15 is the most significant bit
14	BHEN_N	I	Enables access to upper eight bits of data bus when asserted
19-15	ADDR4-0	I	Determines which register will be accessed during an I/O access
31,30,29,28,26	ADDR9-5	I	Determines if an I/O address is within the range occupied by the TNT4882 – the chip is selected and an I/O access occurs when ADDR9-5 match SW9-5 and AEN_N is asserted
20	D15_8_OEN	O	Asserts when DATA15:8 bus is enabled for output – may be left unconnected
21,54	NC	O	Leave unconnected
52,51,23,22,55	SW9-5	I	Determines the base address of the TNT4882
32	DRQ	O	Asserts to request a DMA transfer cycle
33	DACKN	I	Enables FIFO accesses during a DMA transfer cycle
34	INTR	O	Asserts when one or more of the unmasked interrupt conditions becomes true
37	AEN_N	I	Enables I/O accesses to the TNT4882
38	IOCHRDY	OC	When the TNT4882 is not accessed, this open-collector signal is not driven, and a pull-up resistor on the system board keeps it pulled high – at the start of some TNT4882 accesses, the TNT4882 may drive it low, then pull it high again during the cycle to indicate that the TNT4882 is ready for the CPU to end that cycle
50,49,47,46,44,43,42,39	DATA7-0	I/O	Lower eight bits of bidirectional three-state data bus for transfer of commands, data, and status between TNT4882 and CPU – can connect directly to the AT bus – DATA7 is the most significant bit
53	MODE	I	Forces the TNT4882 to 7210 (high) or 9914 (low) emulation mode on a hardware reset – may be left unconnected
62	SENSE_8_16N	I	Pull this pin low to tell the TNT4882 that it is connected to a 16-bit bus – leave it unconnected if the TNT4882 is connected to an 8-bit bus
63	IORN	I	Drives the contents of the register selected by ADDR4-0 on the data bus when the TNT4882 is selected
64	IOWN	I	The value on the data bus is latched into the register selected by ADDR4-0 on the rising edge of IOWN when you select the TNT4882
66	IOCS16N	OC	Driven low during an access to the upper data bus
67	RESET	I	Causes a hardware reset and holds the TNT4882 in its idle state while asserted
71,74,77,80,88,89,91,92	DIO8-1N	I/O	8-bit bidirectional IEEE 488 data bus
70,73,76,79,81,82,84,85	RENN, ATNN, SRQN, IFCN, NDACN, NRFDN, DAVN, EOIN	I/O	IEEE 488 control signals
95	XTALO	O	Output of crystal circuit – use only for driving a quartz crystal
96	XTAL1	I	Crystal oscillator input – drive with a 40 MHz CMOS input level clock signal
98	KEYCLKN	O	Strobes data to or from the DS1204 electronic key
99	KEYDQ	I/O	Transmits serial data between the TNT4882 and a DS1204 key
100	KEYRSTN	O	Resets a DS1204 key
4,8,13,25,27,35,41,45,48,57,61,65,68,72,75,78,83,86,90,93,97	GND	–	Ground pins – 0 V
12,24,36,40,56,58,59,60,69,87,94	VDD	–	Power pins – +5 V ($\pm 5\%$)

TNT4882

Single-Chip IEEE 488.2 Talker/Listener ASIC

TNT4882 Register Map

		NAT4882 Registers					
		7210 Mode		9914 Mode		9914 Mode Swapped	
ADDR4-0	Hex Offset	Read Register	Write Register	Read Register	Write Register	Read Register	Write Register
00000	0	DIR	CDOR	ISRO	IMRO	DIR	CDOR
00010	2	ISR1	IMR1	ISR1	IMR1	CPTR	PPR
00100	4	ISR2	IMR2	ADSR	IMR2	SPSR	SPMR
"	"				EOSR		
"	"				BCR		
"	"				ACCR		
00110	6	SPSR	SPMR	BSR	AUXCR	ISR2	ADR
01000	8	ADSR	ADMR	ISR2	ADR	ADSR	IMR2
"	"						EOSR
"	"						BCR
"	"						ACCR
01010	A	CPTR	AUXMR	SPSR	SPMR	BSR	AUXCR
01100	C	ADRO	ADR	CPTR	PPR	ISRO	IMRO
01110	E	ADR1	EOSR	DIR	CDOR	ISR1	IMR1
10001	11	DSR	SH_CNT	-	-	-	-
10011	13	-	HIER	-	-	-	-
10101	15	-	MISC	-	-	-	-
10111	17	CSR	KEYREG	-	-	-	-
11011	1B	SASR	DCR	-	-	-	-
11101	1D	ISRO	IMRO	-	-	-	-
11111	1F	BSR	BCR	-	-	-	-
		Turbo488 Registers (Same in All Modes)					
ADDR4-0	Hex Offset	Read Register			Write Register		
01001	9	CNT2			CNT2		
01011	B	CNT3			CNT3		
01101	D	-			HSEL		
10000	10	STS1			CFG		
10010	12	IMR3			IMR3		
10100	14	CNT0			CNT0		
10110	16	CNT1			CNT1		
11000	18	FIFOB			FIFOB		
11001	19	FIFOA			FIFOA		
11010	1A	ISR3			CCR		
11100	1C	STS2			CMDR		
11110	1E	TIMER			TIMER		
		Special Registers Only Accessible in ISA Pin Configuration					
ADDR4-0	Hex Offset	Read Register			Write Register		
00101	5	-			ACCWR		
00111	7	-			INTR		

Notes on Register Map

- For complete register descriptions, see the "TNT4882 Programmer Reference Manual" (320724-01)
- Some of the 7210 mode registers, such as the ISR1, have the same names as some of the 9914 mode registers. The 7210 mode registers are NOT the same as their 9914 mode counterparts. Be sure to refer to the appropriate bit map for the chip emulation mode you are using when programming these registers.
- The shaded registers are "paged-in registers." Paged-in registers only exist in 9914 mode. Writing to the address of the 9914 mode ADSR normally does not access any registers. Writing one of four page-in commands to the AUXCR changes all subsequent writes to that address to that of the

corresponding paged-in register. The two readable paged-in registers, the 9914 mode SPSR and ISR2, are both paged in whenever any one of the four writable paged-in registers is paged in. When you write the clear page-in command to the AUXCR, all paged-in registers are paged out again and are no longer accessible.

- There are several unused bytes in the address space of the TNT4882. These addresses are reserved for adding new features to the chip. You should not map any external hardware into these addresses or access them at any time, as this may cause compatibility problems with future versions of the TNT4882.

TNT4882

Single-Chip IEEE 488.2 Talker/Listener ASIC

Hardware Interfacing – ISA Mode TNT4882

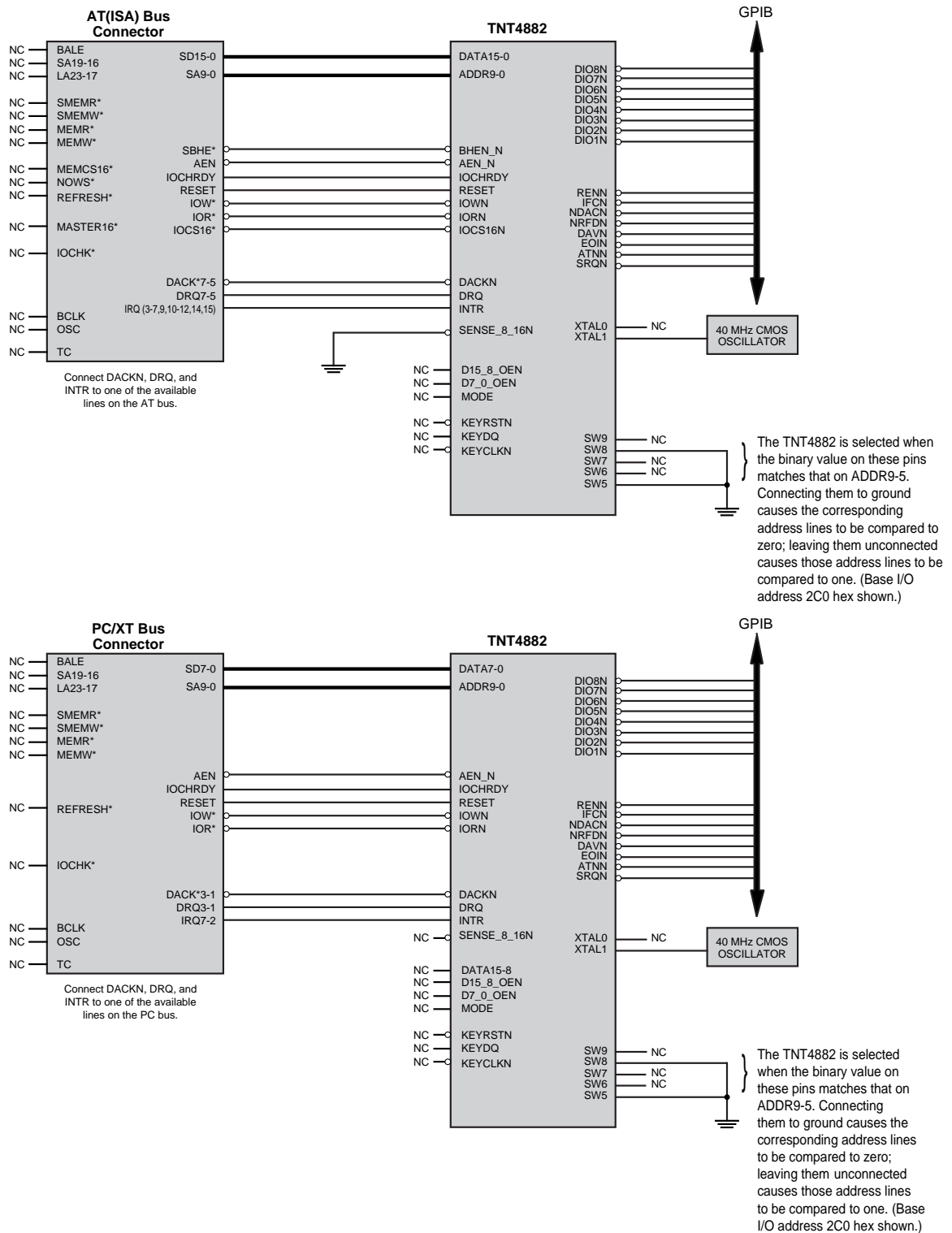

Figure 5. PC/XT and AT (ISA) Bus to ISA Mode TNT4882

TNT4882

Single-Chip IEEE 488.2 Talker/Listener ASIC

ISA Pin Configuration Byte Lane Table

This table shows which byte lane accesses the TNT4882 internal registers during an I/O access when you use the ISA pin configuration. All combinations of ADDR4-1, SENSE_8_16N, and BHEN_N not shown in this table are illegal. You should not apply these combinations to the TNT4882 while the chip is selected. The accessed register is determined only by ADDR4-0, not SENSE_8_16N or BHEN_N.

SENSE_8_16N	BHEN_N	ADDR4-0	IORN	IOWN	DATA15-8	DATA7-0
0	0	11000	0	1	FIFOA	FIFOB
0	0	11000	1	0	FIFOA	FIFOB
0	0	XXXX1	0	1	Read	Not Driven
0	0	XXXX1	1	0	Written	Ignored
0	1	XXXX0	0	1	Not Driven	Read
0	1	XXXX0	1	0	Ignored	Written
1	1	XXXX0	0	1	Not Driven	Read
1	1	XXXX0	1	0	Ignored	Written
1	1	XXXX1	0	1	Not Driven	Read
1	1	XXXX1	1	0	Ignored	Written

TNT4882

Single-Chip IEEE 488.2 Talker/Listener ASIC

Hardware Interfacing – Generic Mode TNT4882

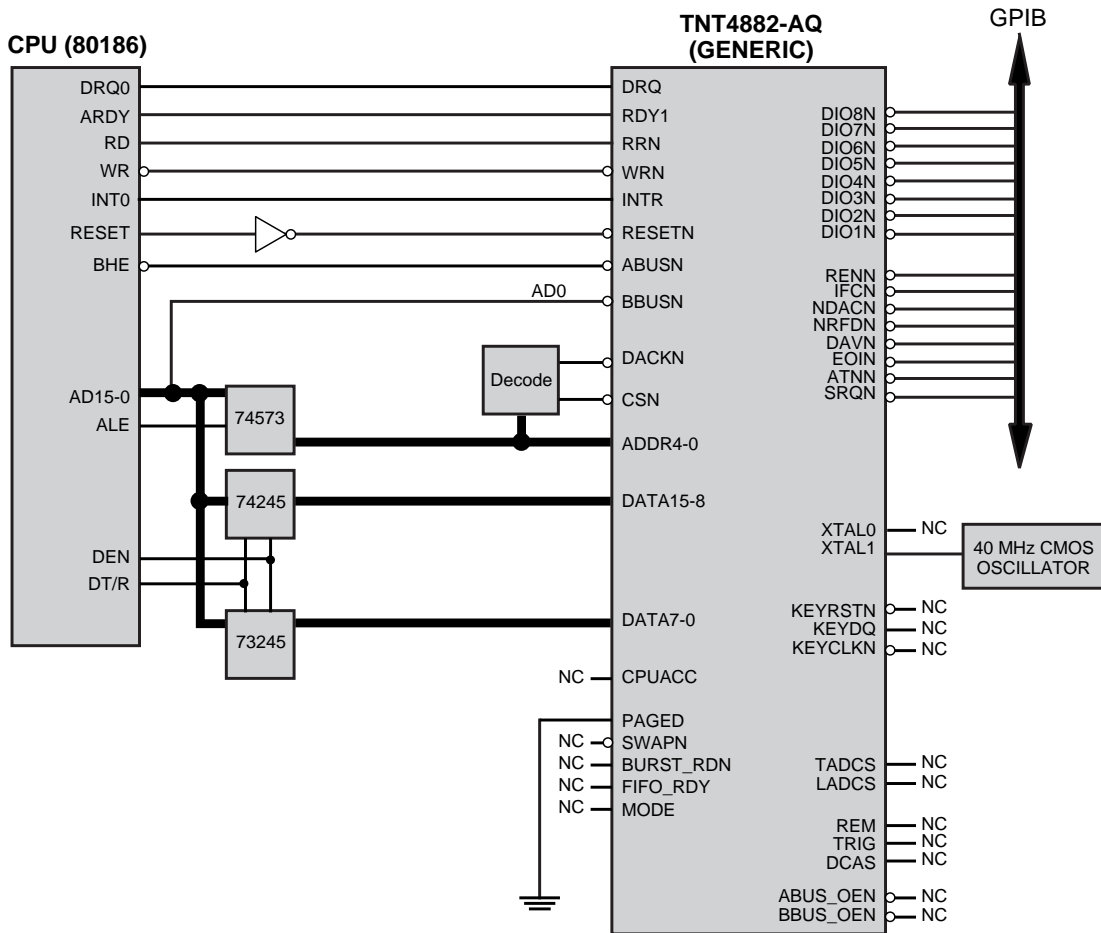

Figure 6. Intel CPU to Generic Mode TNT4882

Generic Pin Configuration Byte Lane Table

This table shows which byte lanes will access TNT4882 registers during I/O accesses.

ABUSN	BBUSN	ADDR4-0	D15-8	D7-0
0	1	11000	FIFOB	unused
1	0	11000	unused	FIFOB
0	0	11000	FIFOA	FIFOB
0	1	XXXXX*	used	unused
1	0	XXXXX*	unused	used

*Any address except 11000

TNT4882

Single-Chip IEEE 488.2 Talker/Listener ASIC

Generic Mode DC Characteristics

Parameter	Symbol	Min	Max	Unit	Notes
Supply voltage	V _{DD}	4.75	5.25	V	
Voltage input low	V _{IL}	-0.5	0.8	V	
Voltage input high	V _{IH}	2.0	V _{CC}	V	
Voltage output low	V _{OL}	0.0	0.4	V	
Voltage output high	V _{OH}	2.4	V _{DD}	V	
Supply current	I _{DD}		90	mA	50 mA, typical
Output current low DATA15-0, LADCS, DRQ, INTR, RDY1	I _{OL}		24	mA	V _{OL} = 0.4 V
Output current low BBUS_OEN, ABUS_OEN, TADCS, CPUACC, REM, TRIG, DCAS, CIC FIFO_RDY	I _{OL}		8	mA	V _{OL} = 0.4 V
Output current low KEYDQ, KEYRSTN, KEYCLKN	I _{OL}		4	mA	V _{OL} = 0.4 V
Output current low KEYDQ, KEYRSTN, KEYCLKN	I _{OL}		2	mA	V _{OL} = 0.4 V
Output current low DIO8-1N, IFCN, SRON, EOIN, ATNN, RENN, DAVN, NRFDN, NDACN	I _{OL}		48	mA	V _{OL} = 0.4 V
Output current high DATA15-0, LADCS, DRQ, INTR, RDY1	I _{OH}		-12	mA	V _{OH} = V _{DD} -0.5 V
Output current high DATA15-0, LADCS, DRQ, INTR, RDY1	I _{OH}		-24	mA	V _{OH} = 2.4 V
Output current high BBUS_OEN, ABUS_OEN, TADCS, CPUACC, REM, TRIG, DCAS	I _{OH}		-4	mA	V _{OH} = V _{DD} -0.5 V
Output current high BBUS_OEN, ABUS_OEN, TADCS, CPUACC, REM, TRIG, DCAS	I _{OH}		-8	mA	V _{OH} = 2.4 V
Output current high FIFO_RDY	I _{OH}		-2	mA	V _{OH} = V _{DD} -0.5 V
Output current high FIFO_RDY	I _{OH}		-4	mA	V _{OH} = 2.4 V
Output current high KEYDQ, KEYRSTN, KEYCLKN	I _{OH}		-1	mA	V _{OH} = V _{DD} -0.5 V
Output current high KEYDQ, KEYRSTN, KEYCLKN	I _{OH}		-2	mA	V _{OH} = 2.4 V
Output current high DIO8-1N, IFCN, SRON, EOIN, ATNN, RENN, DAVN, NRFDN, NDACN	I _{OH}		16	mA	V _{OH} = 2.4 V
Input leakage current – all pins	I _{IH}		±10	µA	V _{DD} = 5.5 V
Output leakage current – all pins	I _{OZ}		±10	µA	V _{DD} = 5.5 V

Generic Mode Capacitance

Parameter	Symbol	Min	Typ	Max	Unit	Notes
Pin capacitance DIO8-1N, RENN, ATNN, IFCN, SRON, DAVN, EOIN, NDACN, NRFDN	C			50	pF	
Pin capacitance all other pins	C		3.6		pF	

Generic Mode AC Characteristics

Parameter	Symbol	Commercial		Industrial		Unit
		Min	Max	Min	Max	
Address setup to RDN = 0, WRN = 0	t _{AS}	24		27		ns
Data delay from RDN = 0, CSN = 0 (one-chip mode access)	t _{RD}		71		78	ns
Data float from RDN = 1	t _{DF}		40		44	ns
RDN pulsewidth (I/O access)	t _{RW}	71		78		ns
RDN recovery width	t _{RR}	40		44		ns
Address hold from RDN = 1, WRN = 1	t _{AH}	0		0		ns
DRQ unassertion	t _{DU}		78		86	ns
Data delay from RDN = 0, DACKN = 0	t _{DR}		40		44	ns
Data setup to WRN = 1	t _{WS}	14		16		ns
Data hold from WRN = 1	t _{WH}	0		0		ns
CSN setup to RDN or WRN	t _{CS}	0		0		ns
CSN hold from RDN or WRN	t _{CH}	0		0		ns
DACKN setup to RDN or WRN	t _{DS}	0		0		ns
DACKN hold from RDN or WRN	t _{DH}	0		0		ns
RDN or WRN to CPUACC (two-chip mode NAT4882 access only)	t _{CPU}		26		29	ns
RDN or WRN to RDY1 assert	t _{ARDY}					
Two-chip mode NAT4882 access			10		10	clock periods
Other accesses			25		28	ns
RDN or WRN to RDY1 unassert	t _{URDY}		22		25	ns
WRN pulse width (DMA access)	t _{WP}	40		44		ns
RDN pulse width (DMA access)	t _{RP}	40		44		ns

TNT4882

Single-Chip IEEE 488.2 Talker/Listener ASIC

Generic Mode AC Characteristics Waveforms

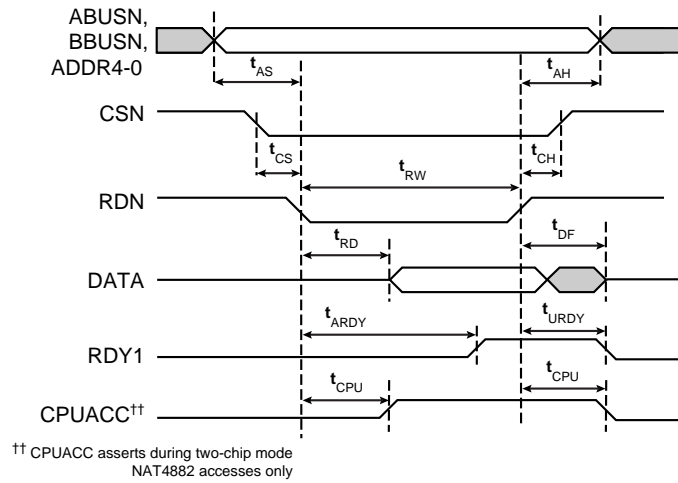

Figure 7. CPU Read

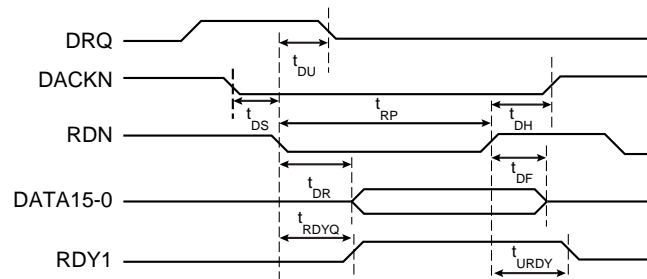

Figure 8. DMA Read

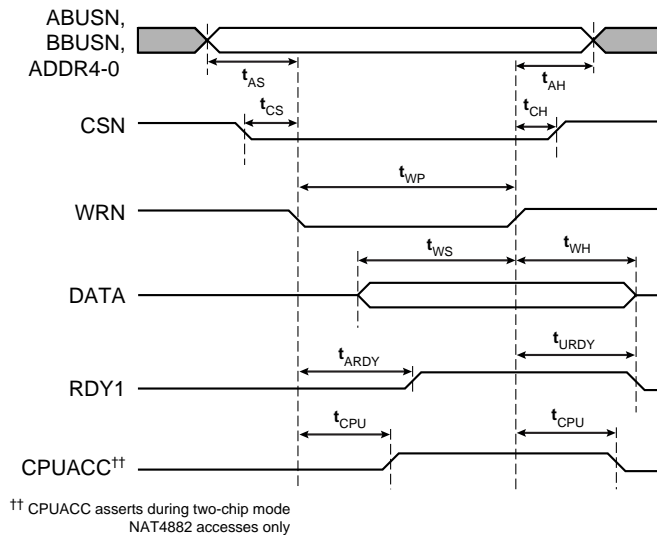

Figure 9. CPU Write

Waveforms continued on page 12

TNT4882

Single-Chip IEEE 488.2 Talker/Listener ASIC

Waveforms continued from page 11

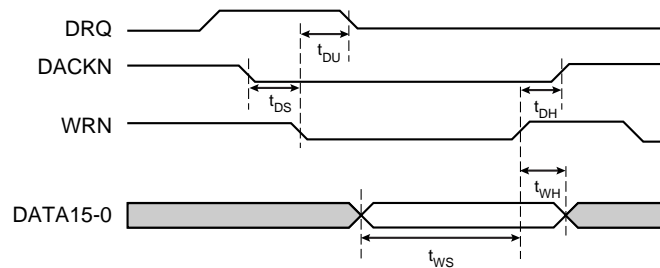

Figure 10. DMA Write

ISA Mode DC Characteristics

Parameter	Symbol	Min	Max	Unit	Notes
Supply voltage	V_{DD}	4.75	5.25	V	
Voltage input low	V_{IL}	-0.5	0.8	V	
Voltage input high	V_{IH}	2.0	V_{CC}	V	
Voltage output low	V_{OL}	0.0	0.4	V	
Voltage output high	V_{OH}	2.4	V_{DD}	V	
Supply current	I_{DD}		90	mA	50 mA, typical
Output current low DATA15-0 DRQ, INTR, IOCS16, IOCHRDY	I_{OL}		24	mA	$V_{OL} = 0.4$ V
Output current low D7_0_OEN	I_{OL}		16	mA	$V_{OL} = 0.4$ V
Output current low D15_8_OEN, TP_INTWTN	I_{OL}		8	mA	$V_{OL} = 0.4$ V
Output current low KEYDQ, KEYRSTN, KEYCLKN	I_{OL}		2	mA	$V_{OL} = 0.4$ V
Output current low DIO8-1N, RENN, ATNN, IFCN, SRQN, DAVN, EOIN, NDACN, NRFDN	I_{OL}		48	mA	$V_{OL} = 0.4$ V
Output current high DATA15-0 DRQ, INTR	I_{OH}		-12	mA	$V_{OH} = V_{DD} - 0.5$ V
Output current high D7_0_OEN	I_{OH}		-8	mA	$V_{OH} = 2.4$ V
Output current high D15_8_OEN, TP_INTWTN	I_{OH}		-4	mA	$V_{OH} = V_{DD} - 0.5$ V
Output current high KEYDQ, KEYRSTN, KEYCLKN	I_{OH}		-8	mA	$V_{OH} = 2.4$ V
Output current high DIO8-1N, RENN, ATNN, IFCN, SRQN, DAVN, EOIN, NDACN, NRFDN	I_{OH}		-1	mA	$V_{OH} = V_{DD} - 0.5$ V
Output current high DIO8-1N, RENN, ATNN, IFCN, SRQN, DAVN, EOIN, NDACN, NRFDN	I_{OH}		-2	mA	$V_{OH} = 2.4$ V
Output current high DIO8-1N, RENN, ATNN, IFCN, SRQN, DAVN, EOIN, NDACN, NRFDN	I_{OH}		-16	mA	$V_{OH} = 2.4$ V
Input leakage current – all pins	I_{IH}		±10	mA	$V_{DD} = 5.5$ V
Output leakage current – all pins	I_{OZ}		±10	mA	$V_{DD} = 5.5$ V

TNT4882

Single-Chip IEEE 488.2 Talker/Listener ASIC

ISA Mode Capacitance

Parameter	Symbol	Min	Typ	Max	Unit	Notes
Pin capacitance DATA15-0, DRQ, INTR, IOCS16N, IOCHRDY, ADDR6	C		3.6		pF	
Pin capacitance D7_0_OEN, D15_8_OEN, TP_INTWTN, KEYDQ, KEYRSTN, KEYCLKN, ADDR4, ADDR8, ADDR9	C		3.0		pF	
Pin capacitance BHEN_N, ADDR3-0, ADDR5, ADDR7, DACKN, AEN_N, MODE, TESTMODE, PWBSSEL2-0, SW9, SENSE_8_16N, IORN, IOWN, RESET	C		3.5		pF	
Pin capacitance DIO8-1N, RENN, ATNN, IFCN, SRQN, DAVN, EOIN, NDAACN, NRFDN	C			50	pF	

ISA Mode AC Characteristics

Parameter	Symbol	Min	Max	Unit	Notes
ADDR9-0 setup to IORN, IOWN	t_{AS}	30		ns	
ADDR9-0 hold from IORN, IOWN	t_{AH}	0		ns	
DACKN setup to IORN, IOWN	t_{DS}	0		ns	
DACKN hold from IORN, IOWN	t_{DH}	20		ns	
Data setup time to IOWN rising	t_{SU}	22		ns	
Data hold time from IOWN rising	t_{WH}	0		ns	
IORN low pulse width	t_{RPWL}	100		ns	
IORN high pulse width	t_{RPWH}	42		ns	
IOWN low pulse width	t_{WPWL}	100		ns	
IOWN high pulse width	t_{WPWH}	100		ns	
IORN or IOWN held from IOCHRDY	t_{TD}	20		ns	
DRQ unassertion time	t_{DU}		73	ns	Due to FIFO full/empty
DRQ unassertion time	t_{DU}		48	ns	Due to byte count reached
Data access time from IORN falling, DMA	t_{DACC}		80	ns	
Data access time from IORN falling, I/O	t_{ACC}		80	ns	
Data hold time from IORN rising	t_{RH}	0		ns	
Data float time from IORN rising	t_{DF}		30	ns	
IOCS16N assertion after valid address	t_{DEC}		30	ns	
IOCS16N negation after invalid address	t_{DECN}		20	ns	
IOCHRDY negation from IORN or IOWN	t_{RDYN}		40	ns	
IOCHRDY release after IORN or IOWN	t_{RDY}		350	ns	

ISA Mode AC Characteristics Waveforms

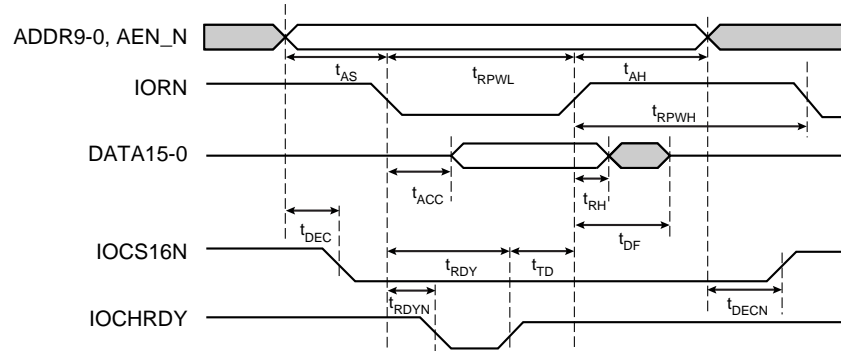

Figure 11. I/O Read Access

Waveforms continued on page 14

TNT4882

Single-Chip IEEE 488.2 Talker/Listener ASIC

Waveforms continued from page 13

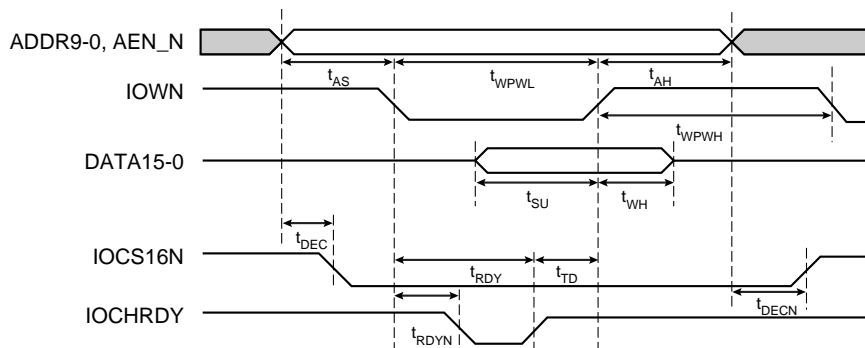

Figure 12. I/O Write Access

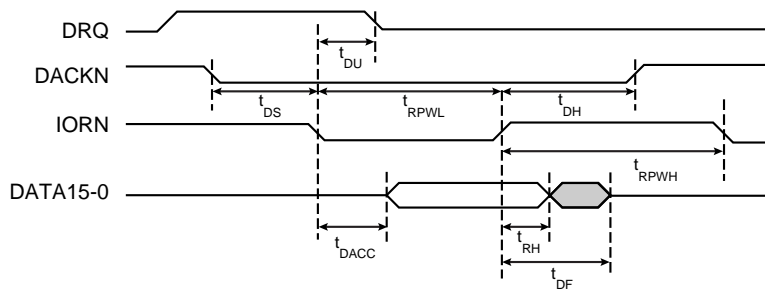

Figure 13. DMA Read Access

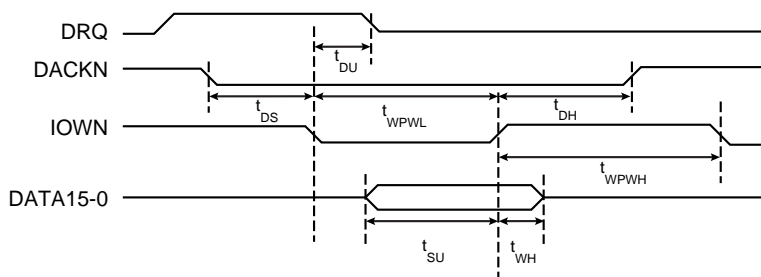

Figure 14. DMA Write Access

TNT4882

Single-Chip IEEE 488.2 Talker/Listener ASIC

Absolute Maximum Ratings

Property	Range	Units
Supply voltage, V_{DD}	- 0.5 to + 7.0	V
Input voltage, V_{IN}	- 0.5 to $V_{CC} + 0.5$	V
Output voltage, V_{OUT}	- 0.5 to $V_{CC} + 0.5$	V
Storage temperature, T_{STG}	- 55 to 150	° C

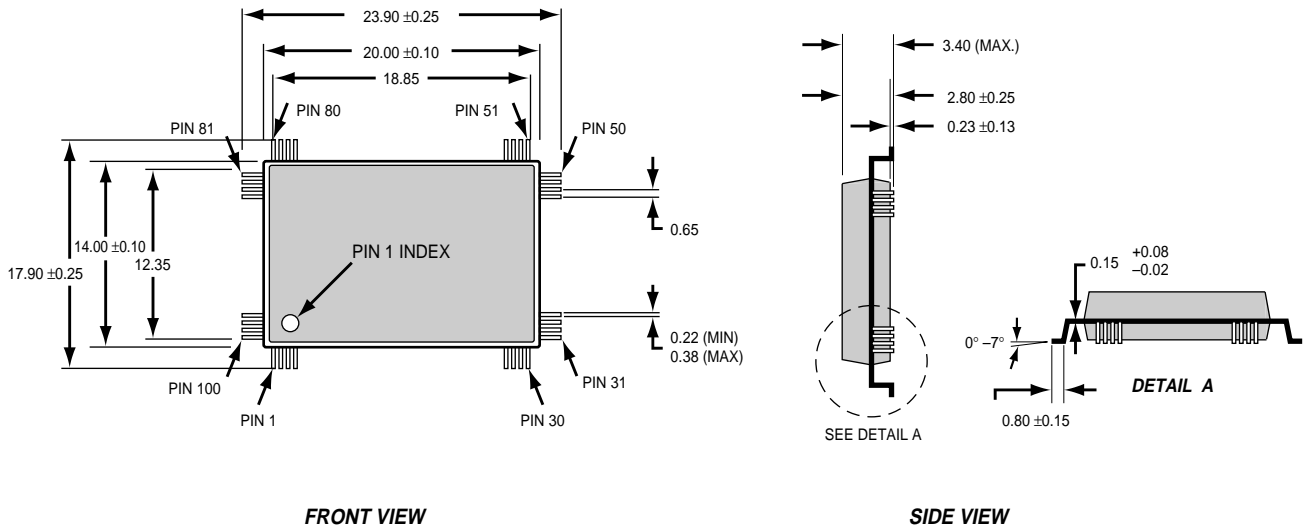

NOTES:

1. All dimensions are shown in millimeters.
2. Unless otherwise specified, all dimensions are nominal.
3. When converting from millimeters to inches, four significant digits to the right of the decimal point are necessary.

Figure 16. Mechanical Data

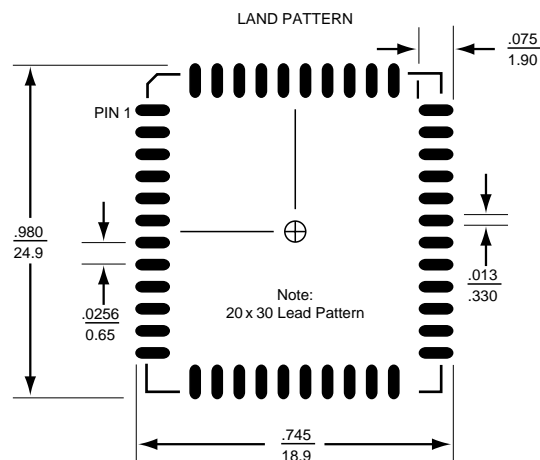

Figure 17. Recommended Land Pattern (not to scale)

TNT4882

Single-Chip IEEE 488.2 Talker/Listener ASIC

Technical Support

National Instruments strives to provide you with quality technical assistance worldwide. We currently offer electronic technical support along with our technical support centers staffed by Applications Engineers.

Access information from our Web site at www.natinst.com. Our FTP site is dedicated to 24-hour support, with a collection of files and documents to answer your questions. Log on to our Internet host at [ftp.natinst.com](ftp://ftp.natinst.com)

You can fax questions to our Applications Engineers anytime at (800) 328-2203 or (512) 683-5678. Or, you can call from 8:00 a.m. to 6:00 p.m. (central time) at (512) 795-8248. Internationally, contact your local office. National Instruments sponsors a wide variety of group activities, such as user group meetings at trade shows and at large industrial sites. Our users also receive our quarterly *Instrumentation Newsletter*™ with the latest information on new products, product updates, application tips, and current events. In addition, sign up for *NI News*, our electronic news service at www.natinst.com/news

Warranty

All National Instruments data acquisition, computer-based instrument, VXIbus, and MXIbus products are covered by a one-year warranty. GPIB hardware products are covered by a two-year warranty from the date of shipment. The warranty covers board failures, components, cables, connectors, and switches, but does not cover faults caused by misuse. The owner may return a failed assembly to National Instruments for repair during the warranty period. Extended warranties are available at an additional charge.

Information furnished by National Instruments is believed to be accurate and reliable. National Instruments reserves the right to change product specifications without notice.

Seminars/Training

Free and fee-paid seminars are presented several times a year in cities around the world. Comprehensive, fee-paid training courses are available at National Instruments offices or at customer sites. Call for training schedules.

For More Information

Contact National Instruments for Application Notes such as:

- "Using the TNT4882 in a MC68340 System"
- "Factors to Consider When Clocking the TNT4882 at Frequencies Less than 40 MHz"
- "Porting a 9914 GPIB Design to Use the TNT4882"

Ordering Information

- TNT4882-BQ
- TNT4882 Developer Kit.....776866-01
Includes 2 TNT4882 ASICs, PC AT evaluation board, ESP-488TL source code software, and documentation.
- TNT4882 Programmer Reference Manual.....320724-01

Part Number Legend

a	b	c	d	e
TNT	4882		B	Q

- a. Family name TNT = Single-chip, high-speed, GPIB Talker/Listener interface
- b. Device-number 4882 = IEEE 488.2 compatible
- c. Reserved
- d. Revision
- e. Package type Q = Quad flat pack



340570D-01

www.natinst.com (512) 794-0100

U.S. Corporate Headquarters Fax (512) 683-9300 • info@natinst.com
Branch Offices: Australia 03 9879 5166 • Austria 0662 45 79 90 0 • Belgium 02 757 00 20 • Brazil 000 811 781 0559 • Canada 905 785 0085
China 86 21 6555 7838 • Denmark 45 76 26 00 • Finland 09 725 725 11 • France 01 48 14 24 24 • Germany 089 741 31 30 • Hong Kong 2645 3186
India 91805275406 • Israel 03 6120092 • Italy 02 413091 • Japan 03 5472 2970 • Korea 02 596 7456 • Mexico 001 800 010 0793
Netherlands 0348 433466 • New Zealand 09 914 0488 • Norway 32 27 73 00 • Singapore 2265886 • Spain 91 640 0085 • Sweden 08 587 895 00
Switzerland 056 200 51 51 • Taiwan 02 2377 1200 • U.K. 01635 523545