

### Description

The ASM07 is an uni-directional TVS diode array, utilizing leading monolithic silicon technology to provide fast response time and low ESD clamping voltage, making this device an ideal solution for protecting sensitive semiconductor components from damage. The ASM07 complies with the IEC 61000-4-2 (ESD) with  $\pm 30\text{kV}$  air and  $\pm 30\text{kV}$  contact discharge. It is assembled into a lead-free SOT-23 package. It is designed to protect components which are connected to data and transmission lines from voltage surges.

### Features

- 300W peak pulse power (8/20 $\mu\text{s}$ )
- Protects one two uni-directional line(s)
- Ultra low leakage: nA level
- Operating voltage: 5V
- Low clamping voltage
- Complies with following standards:
  - IEC 61000-4-2 (ESD) immunity test
    - Air discharge:  $\pm 30\text{kV}$
    - Contact discharge:  $\pm 30\text{kV}$
  - IEC61000-4-5 (Lightning) 20A (8/20 $\mu\text{s}$ )
- RoHS Compliant

### Mechanical Characteristics

- Package: SOT-23
- Lead Finish: Matte Tin
- Case Material: "Green" Molding Compound.
- Moisture Sensitivity: Level 3 per J-STD-020
- Terminal Connections: See Diagram Below
- Marking Information: See Below

### Applications

- Peripherals
- Industrial Equipment
- Notebook Computers
- Portable Instrumentation
- Microprocessor Based Equipment
- Cell Phone Handsets and Accessories
- Personal Digital Assistants (PDAs) and Pagers

### Marking Information

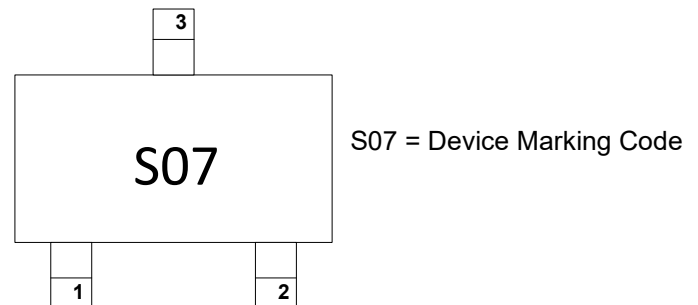

### Ordering Information

| Part Number | Packaging        | Reel Size |
|-------------|------------------|-----------|
| ASM07       | 3000/Tape & Reel | 7 inch    |

### Dimensions and Pin Configuration

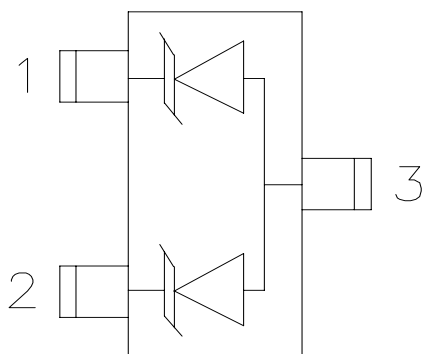

**SOT23**

Circuit and Pin Schematic

**Absolute Maximum Ratings ( $T_A=25^{\circ}\text{C}$  unless otherwise specified)**

| Parameter                                | Symbol           | Value       | Unit               |
|--|------------------|-------------|--------------------|
| Peak Pulse Power (8/20 $\mu\text{s}$ )   | Ppk              | 300         | W                  |
| Peak Pulse Current (8/20 $\mu\text{s}$ ) | I <sub>PP</sub>  | 20          | A                  |
| ESD per IEC 61000-4-2 (Air)              | V <sub>ESD</sub> | $\pm 30$    | kV                 |
| ESD per IEC 61000-4-2 (Contact)          |                  | $\pm 30$    |                    |
| Operating Temperature Range              | T <sub>J</sub>   | -55 to +125 | $^{\circ}\text{C}$ |
| Storage Temperature Range                | T <sub>stg</sub> | -55 to +150 | $^{\circ}\text{C}$ |

**Electrical Characteristics ( $T_A=25^{\circ}\text{C}$  unless otherwise specified)**

| Parameter                 | Symbol           | Min | Typ | Max | Unit          | Test Condition  |
|---------------------------|------------------|-----|-----|-----|---------------|---|
| Reverse Working Voltage   | V <sub>RWM</sub> |     |     | 7   | V             |   |
| Reverse Breakdown Voltage | V <sub>BR</sub>  | 7.5 |     | 9.5 | V             | I <sub>T</sub> = 1mA  |
| Reverse Leakage Current   | I <sub>R</sub>   |     |     | 0.5 | $\mu\text{A}$ | V <sub>RWM</sub> = 7V, any I/O pin to ground                              |
| Clamping Voltage          | V <sub>C</sub>   |     |     | 10  | V             | I <sub>PP</sub> = 1A (8 x 20 $\mu\text{s}$ pulse), any I/O pin to ground  |
| Clamping Voltage          | V <sub>C</sub>   |     |     | 15  | V             | I <sub>PP</sub> = 20A (8 x 20 $\mu\text{s}$ pulse), any I/O pin to ground |
| Junction Capacitance      | C <sub>J</sub>   |     | 110 |     | pF            | V <sub>R</sub> = 0V, f = 1MHz, any I/O pin to ground                      |

**Typical Performance Characteristics ( $T_A=25^\circ\text{C}$  unless otherwise Specified)**

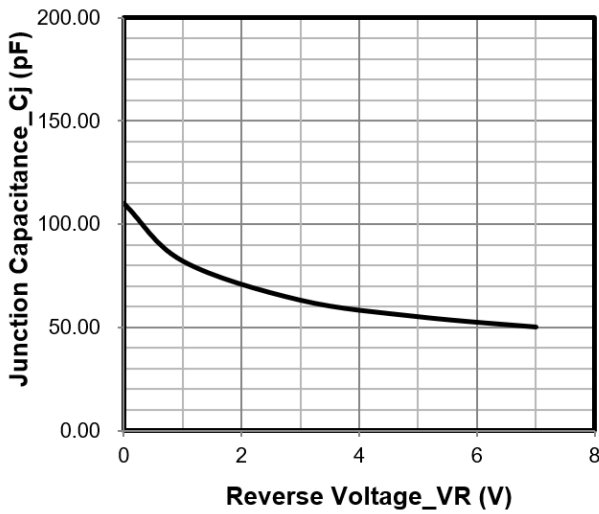

**Junction Capacitance vs. Reverse Voltage**

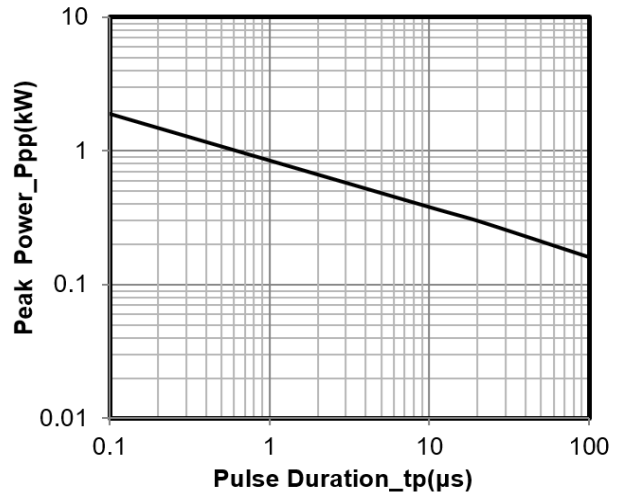

**Peak Pulse Power vs. Pulse Time**

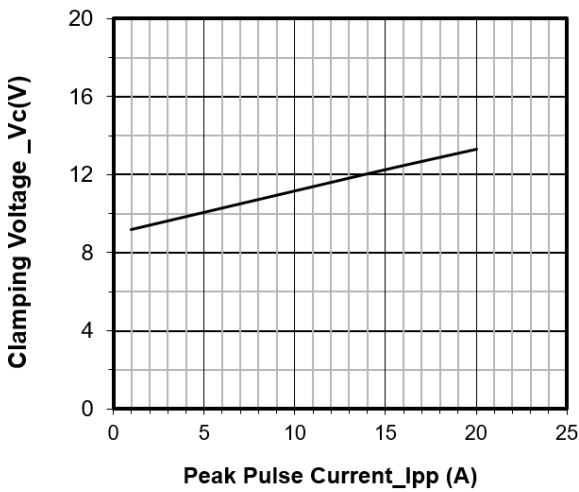

**Clamping Voltage vs. Peak Pulse Current**

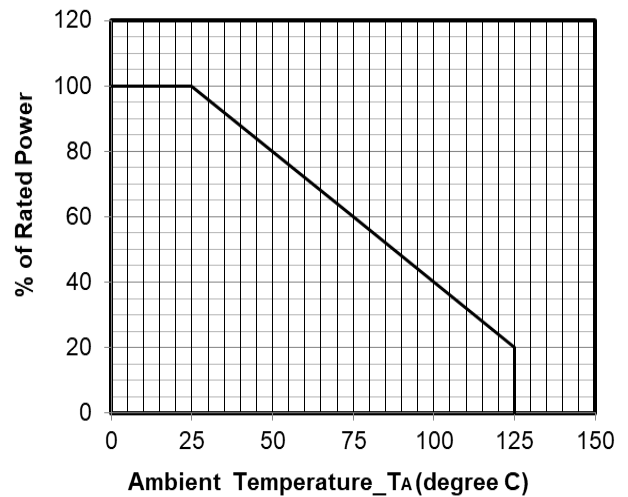

**Power Derating Curve**

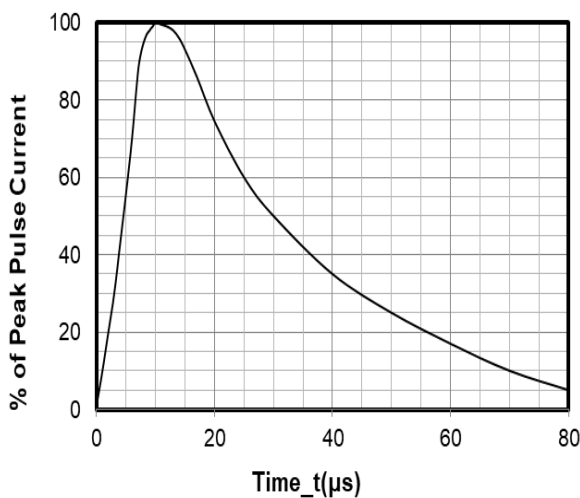

**8 X 20μs Pulse Waveform**

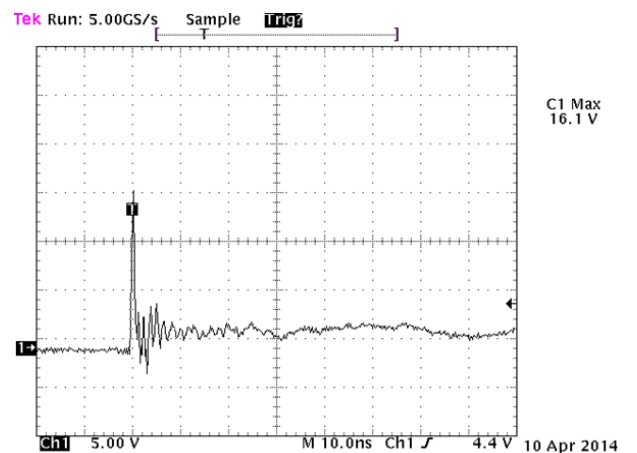

Note: Data is taken with a 10x attenuator

**ESD Clamping Voltage**

**8 kV Contact per IEC61000-4-2**

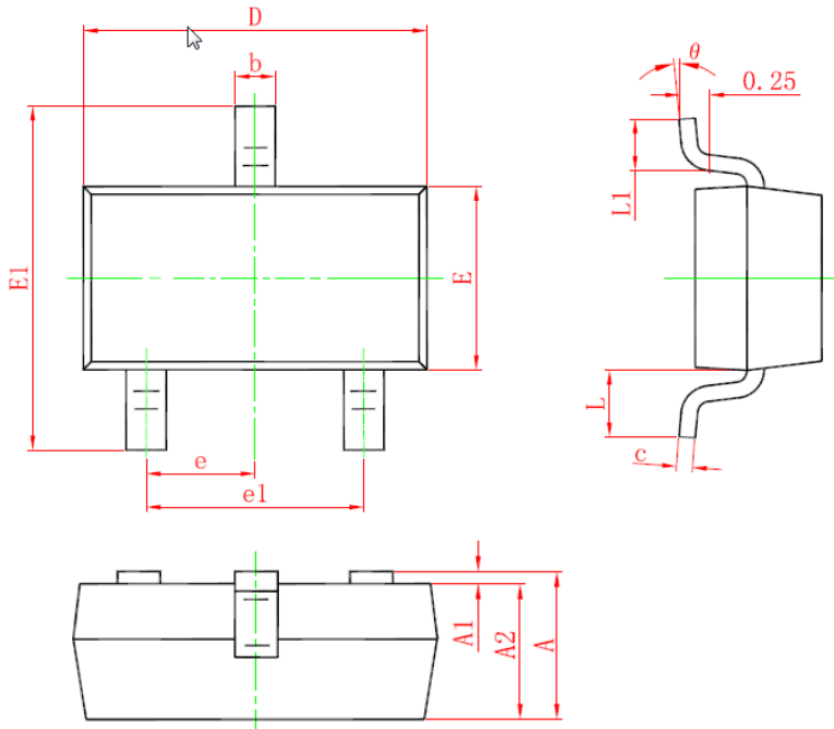
**SOT-23 Package Outline Drawing**

| SYM | DIMENSIONS  |     |      |          |     |       |
|-----|-------------|-----|------|----------|-----|-------|
|     | MILLIMETERS |     |      | INCHES   |     |       |
|     | MIN         | NOM | MAX  | MIN      | NOM | MAX   |
| A   | 0.90        | --  | 1.15 | 0.035    | --  | 0.045 |
| A1  | 0.00        | --  | 0.10 | 0.000    | --  | 0.004 |
| A2  | 0.90        | --  | 1.05 | 0.035    | --  | 0.041 |
| b   | 0.30        | --  | 0.50 | 0.012    | --  | 0.020 |
| c   | 0.08        | --  | 0.15 | 0.003    | --  | 0.006 |
| D   | 2.80        | --  | 3.00 | 0.110    | --  | 0.118 |
| E   | 1.20        | --  | 1.40 | 0.047    | --  | 0.055 |
| E1  | 2.25        | --  | 2.55 | 0.089    |     | 0.100 |
| e   | 0.95TYP     |     |      | 0.037TYP |     |       |
| e1  | 1.80        | --  | 2.00 | 0.071    | --  | 0.079 |
| L   | 0.55REF     |     |      | 0.022REF |     |       |
| L1  | 0.30        | --  | 0.50 | 0.012    | --  | 0.020 |
| Θ   | 0°          | --  | 8°   | 0°       | --  | 8°    |

### Suggested Land Pattern

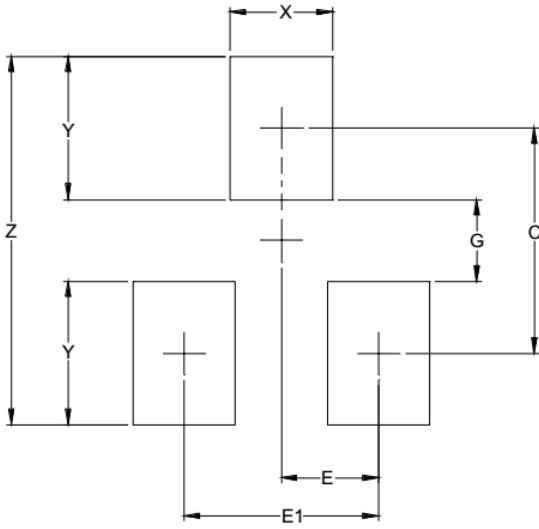

| SYM | DIMENSIONS |             |
|-----|------------|-------------|
|     | INCHES     | MILLIMETERS |
| C   | .087       | 2.20        |
| E   | .037       | 0.95        |
| E1  | .075       | 1.90        |
| G   | .031       | 0.80        |
| X   | .039       | 1.00        |
| Y   | .055       | 1.40        |
| Z   | .141       | 3.60        |

### Contact Information

Applied Power Microelectronics Co., Ltd.

Website: <http://www.appliedpowermicro.com>

Email: [sales@appliedpowermicro.com](mailto:sales@appliedpowermicro.com)

Phone: +86 (0519) 8399 3606