

4GE PORT SWITCH WITH INTEGRATED GE COPPER PHY

FEATURES

- Highest silicon integration level achieved for an 4-port, 10/100/1000 Ethernet switch device
- Seventh-generation switch on a chip
- Integrates:
 - Four 10/100/1000 transceivers (802.3ab compliant)
 - Four MACs (802.x compliant) with support for 9 Kbyte Jumbo Frames
 - Nonblocking four Gigabit Ethernet fully integrated switch fabric
 - SPI Interface for easy setup and smart unmanaged operation
- Classifies packets using four 802.1p QoS or DiffServ/TOS priority queues
- VLAN 4k 802.1Q or port-based supported
- Supports up to 8k unicast MAC addresses
- Supports MAC-based port aggregation (trunking)
- Flow control: full-duplex (802.3x) and half-duplex options supported
- Supports automatic address learning and aging
- Internal oscillator circuit
- Low power 0.13 μ m 1.2 V CMOS core: <3.5W Pd.
- Fanless operation supported
- Integrated voltage regulator for simplified power supply design
- 324-pin FBGA package (small form factor 19 mm x 19 mm)

SUMMARY OF BENEFITS

- Industry-first single-chip solution for four Gigabit Ethernet.
- Enables a new generation of lower-cost switches with Gigabit connectivity and much smaller form factors.
- Uses field-proven industry-standard 10/100/1000BASE-T transceivers-lowers overall system interoperability and reliability risks.
- Provides the most cost effective Gigabit Ethernet connectivity to the desktop for all remote, branch, and home office needs.
- 802.1Q tag VLAN, trunking, and 802.1p priority enables the switch to be designed into a wide variety of applications from unmanaged to smart switch.
- Jumbo frame support allows the device to be connected to corporate server farms and networks while maintaining maximum TCP/IP performance.
- CPUs are not required to initialize and run in cost-sensitive unmanaged applications, providing true Plug and Play connectivity.
- Internal oscillator circuit simplifies design and reduces overall system cost.
- On-chip HP auto-MDI/MDIX on all transceivers automatically detects and corrects for crossover cables and allows direct switch-to-switch connection.
- Lowest possible system cost through minimized number of components.
- Higher system reliability and noise reduction due to elimination of component with lowest MTBF (the fan).

4 Gigabit Ethernet Ports for SOHO and Subnetwork Applications

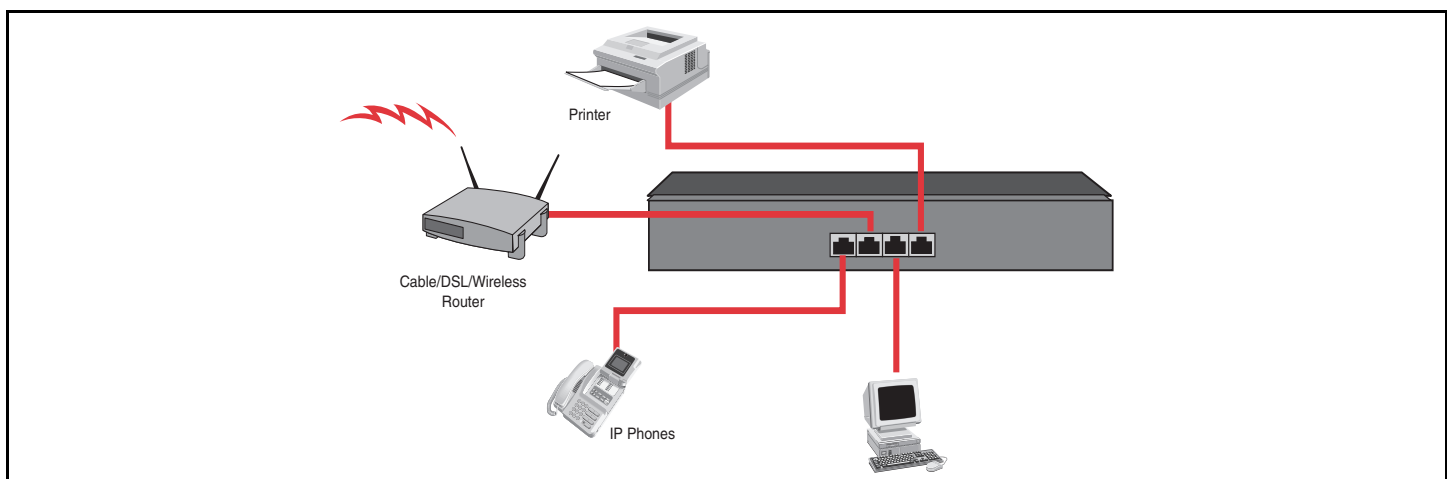

OVERVIEW

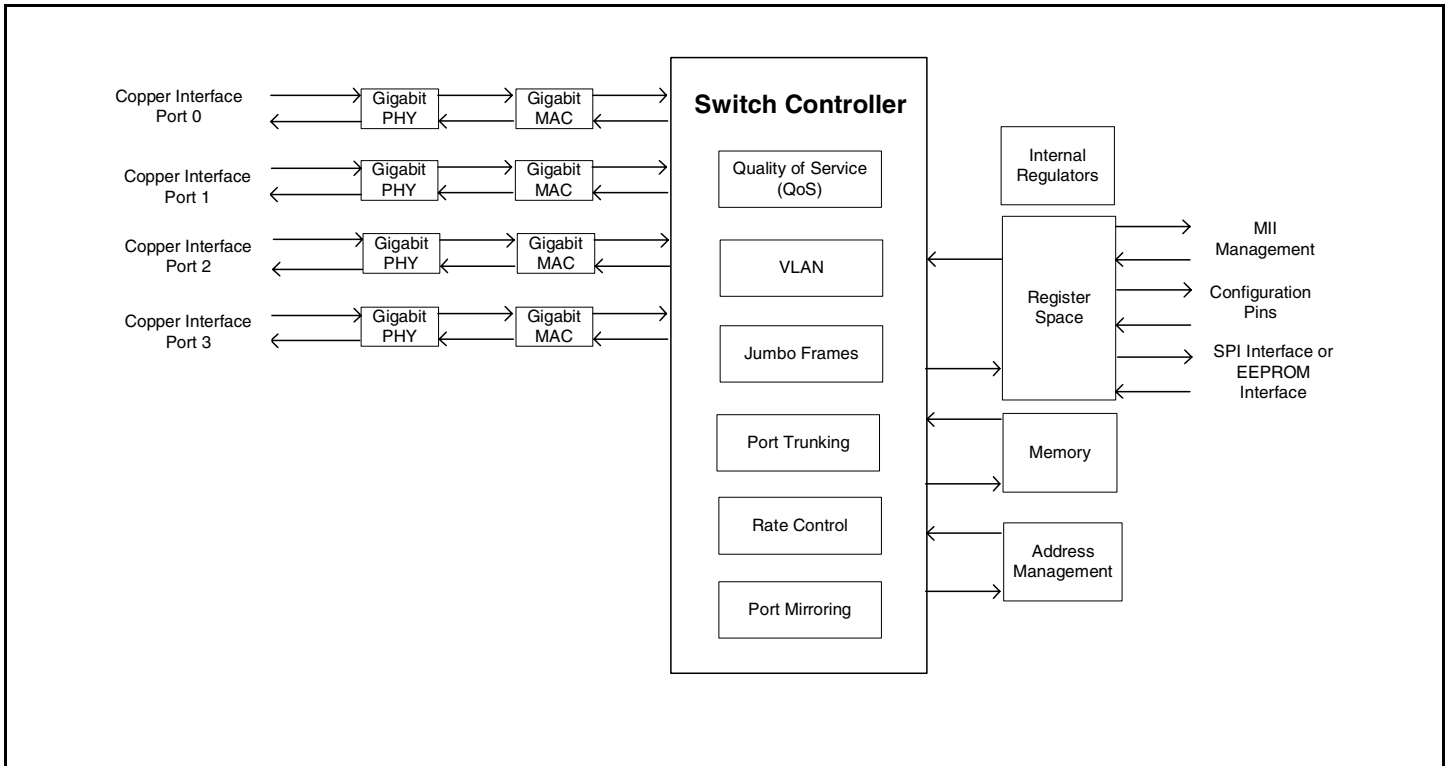

The Broadcom BCM5384 device is a highly integrated solution. It combines all the functions of a high-speed switch system, including packet buffer, PHY transceivers, media access controllers, address management, and a nonblocking switch fabric into a single 0.13 μm CMOS device. It complies with IEEE 802.3, 802.3u, 802.3ab, and 802.3x specifications, including the MAC control, pause frame, and auto-negotiation subsections, providing compatibility with all industry-standard Ethernet, Fast Ethernet, and Gigabit Ethernet devices.

This device contains four full-duplex 10/100/1000BASE-T transceivers, each of which performs all of the physical layer interface functions for 10BASE-T Ethernet on Category 3, 4, or 5 unshielded twisted-pair (UTP) cable and 100/1000BASE-T Fast/Gigabit Ethernet on Category 5 UTP cable. The media access controllers on the BCM5384 also support Jumbo Frames which are typically used for high-performance

connections to servers because they offer a smaller percentage of overhead on the link for more efficiency.

SPI or EEPROM interfaces provide easy programming of the on-chip 802.1p QoS and/or DiffServ/TOS. This allows switch traffic to be given different classes of priority or service—for example, voice traffic for IP phone applications, video traffic for multimedia applications, or data traffic for e-mail applications. Up to 4k virtual LANs (VLANs) can be set up via the SPI port for separation of different users or groups on the network. For multi-Gigabit per second connections, multiple ports of the BCM5384 can be grouped together to form logical links. These links feature automatic load balancing.

Broadcom[®], the pulse logo, and **Connecting everything**[®] are trademarks of Broadcom Corporation and/or its subsidiaries in the United States and certain other countries. All other trademarks mentioned are the property of their respective owners.

Connecting
everything[®]



BROADCOM CORPORATION
16215 Alton Parkway, P.O. Box 57013
Irvine, California 92619-7013

© 2004 by BROADCOM CORPORATION. All rights reserved.

5384-PB02-R 03/25/04

Phone: 949-450-8700
Fax: 949-450-8710
E-mail: info@broadcom.com
Web: www.broadcom.com