



### ANALOG PERIPHERALS

- **10-Bit ADC**
  - Up to 200 kbps
  - Up to 17 or 13 External Single-Ended or Differential Inputs
  - VREF from External Pin, Internal Reference, or VDD
  - Built-in Temperature Sensor
  - External Conversion Start Input

### - Two Comparators

### - Internal Voltage Reference

### - POR/Brown-Out Detector

### USB FUNCTION CONTROLLER

- USB Specification 2.0 Compliant
- Full Speed (12 Mbps) or Low Speed (1.5 Mbps) Operation
- Integrated Clock Recovery; No External Crystal Required for Full Speed or Low Speed
- Supports Eight Flexible Endpoints
- 1k Byte USB Buffer Memory
- Integrated Transceiver; No External Resistors Required

### ON-CHIP DEBUG

- On-Chip Debug Circuitry Facilitates Full Speed, Non-Intrusive In-System Debug (No Emulator Required!)
- Provides Breakpoints, Single Stepping, Inspect/Modify Memory and Registers
- Superior Performance to Emulation Systems Using ICE-Chips, Target Pods, and Sockets

**VOLTAGE REGULATOR INPUT: 4.0V TO 5.25V**

### HIGH SPEED 8051 $\mu$ C Core

- Pipelined Instruction Architecture; Executes 70% of Instructions in 1 or 2 System Clocks
- Up to 25 MIPS Throughput with 25 MHz Clock
- Expanded Interrupt Handler

### MEMORY

- 2304 Bytes Internal RAM (1k + 256 + 1k USB FIFO)
- 16k Bytes FLASH; In-system programmable in 512-byte Sectors

### DIGITAL PERIPHERALS

- 25/21 Port I/O; All 5 V tolerant with High Sink Current
- Hardware Enhanced SPI™, Enhanced UART, and SMBus™ Serial Ports
- Four General Purpose 16-Bit Counter/Timers
- 16-Bit Programmable Counter Array (PCA) with Five Capture/Compare Modules
- Real Time Clock Mode using External Clock Source and PCA or Timer

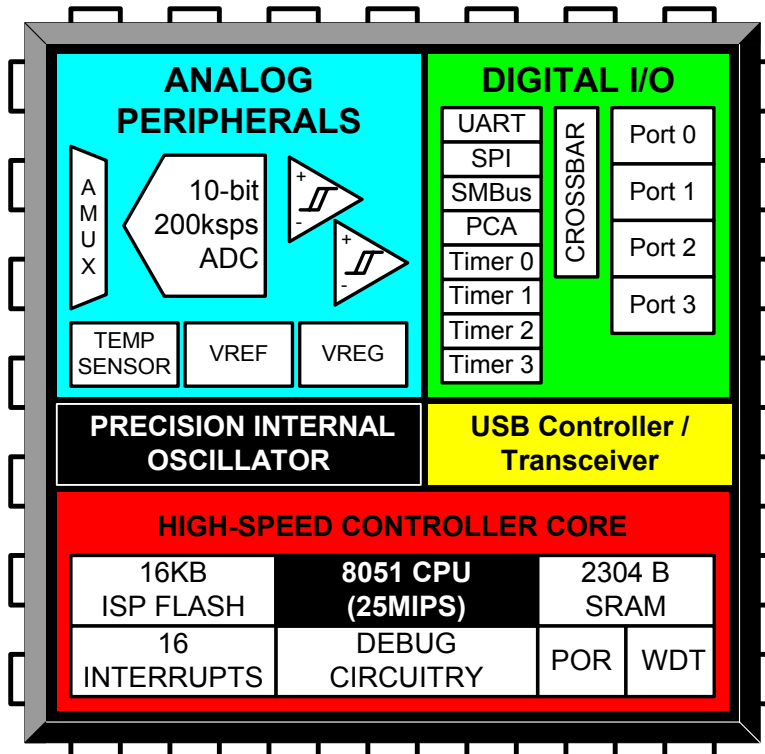
### CLOCK SOURCES

- Internal Oscillator: 0.25% Accuracy with Clock Recovery enabled. Supports all USB and UART Modes
- External Oscillator: Crystal, RC, C, or Clock (1 or 2 Pin Modes)
- Can Switch Between Clock Sources on-the-fly; Useful in Power Saving Strategies

### PACKAGES

- 32-pin LQFP (C8051F320)
- 28-pin MLP (C8051F321)

**TEMPERATURE RANGE: -40°C TO +85°C**



---

*Notes*

---

**TABLE OF CONTENTS**

<b>1. SYSTEM OVERVIEW .....</b>	<b>17</b>
1.1. CIP-51™ Microcontroller Core .....	20
1.1.1. Fully 8051 Compatible .....	20
1.1.2. Improved Throughput .....	20
1.1.3. Additional Features .....	21
1.2. On-Chip Memory .....	22
1.3. Universal Serial Bus Controller .....	23
1.4. Voltage Regulator .....	23
1.5. On-Chip Debug Circuitry .....	24
1.6. Programmable Digital I/O and Crossbar .....	25
1.7. Serial Ports .....	25
1.8. Programmable Counter Array .....	26
1.9. 10-Bit Analog to Digital Converter .....	27
1.10. Comparators .....	28
<b>2. ABSOLUTE MAXIMUM RATINGS .....</b>	<b>29</b>
<b>3. GLOBAL DC ELECTRICAL CHARACTERISTICS .....</b>	<b>30</b>
<b>4. PINOUT AND PACKAGE DEFINITIONS .....</b>	<b>31</b>
<b>5. 10-BIT ADC (ADC0) .....</b>	<b>39</b>
5.1. Analog Multiplexer .....	40
5.2. Temperature Sensor .....	41
5.3. Modes of Operation .....	42
5.3.1. Starting a Conversion .....	42
5.3.2. Tracking Modes .....	43
5.3.3. Settling Time Requirements .....	44
5.4. Programmable Window Detector .....	50
5.4.1. Window Detector In Single-Ended Mode .....	52
5.4.2. Window Detector In Differential Mode .....	53
<b>6. VOLTAGE REFERENCE .....</b>	<b>55</b>
<b>7. COMPARATORS .....</b>	<b>57</b>
<b>8. VOLTAGE REGULATOR (REG0) .....</b>	<b>67</b>
8.1. Regulator Mode Selection .....	68
8.2. VBUS Detection .....	69
<b>9. CIP-51 MICROCONTROLLER .....</b>	<b>73</b>
9.1. Instruction Set .....	75
9.1.1. Instruction and CPU Timing .....	75
9.1.2. MOVX Instruction and Program Memory .....	75
9.2. Memory Organization .....	79
9.2.1. Program Memory .....	79
9.2.2. Data Memory .....	80
9.2.3. General Purpose Registers .....	80
9.2.4. Bit Addressable Locations .....	80
9.2.5. Stack .....	80
9.2.6. Special Function Registers .....	81

# C8051F320/1

---

9.2.7. Register Descriptions .....	84
9.3. Interrupt Handler .....	87
9.3.1. MCU Interrupt Sources and Vectors .....	87
9.3.2. External Interrupts .....	88
9.3.3. Interrupt Priorities.....	88
9.3.4. Interrupt Latency.....	88
9.3.5. Interrupt Register Descriptions.....	90
9.4. Power Management Modes .....	96
9.4.1. Idle Mode.....	96
9.4.2. Stop Mode.....	96
<b>10. RESET SOURCES .....</b>	<b>99</b>
10.1. Power-On Reset.....	100
10.2. Power-Fail Reset / VDD Monitor.....	101
10.3. External Reset.....	102
10.4. Missing Clock Detector Reset .....	102
10.5. Comparator0 Reset .....	102
10.6. PCA Watchdog Timer Reset .....	102
10.7. FLASH Error Reset .....	102
10.8. Software Reset.....	103
10.9. USB Reset .....	103
<b>11. FLASH MEMORY .....</b>	<b>107</b>
11.1. Programming The FLASH Memory .....	107
11.1.1. FLASH Lock and Key Functions .....	107
11.1.2. FLASH Erase Procedure.....	107
11.1.3. FLASH Write Procedure .....	108
11.2. Non-volatile Data Storage .....	109
11.3. Security Options .....	109
<b>12. EXTERNAL RAM .....</b>	<b>113</b>
12.1. Accessing User XRAM .....	113
12.2. Accessing USB FIFO Space.....	114
<b>13. OSCILLATORS.....</b>	<b>117</b>
13.1. Programmable Internal Oscillator .....	117
13.1.1. Programming the Internal Oscillator on C8051F320/1 Devices .....	118
13.1.2. Internal Oscillator Suspend Mode .....	118
13.2. External Oscillator Drive Circuit.....	120
13.2.1. Clocking Timers Directly Through the External Oscillator .....	120
13.2.2. External Crystal Example .....	120
13.2.3. External RC Example .....	121
13.2.4. External Capacitor Example .....	121
13.3. 4x Clock Multiplier .....	123
13.4. System and USB Clock Selection .....	124
13.4.1. System Clock Selection .....	124
13.4.2. USB Clock Selection .....	124
<b>14. PORT INPUT/OUTPUT .....</b>	<b>127</b>
14.1. Priority Crossbar Decoder .....	129

---

14.2. Port I/O Initialization.....	131
14.3. General Purpose Port I/O.....	134
<b>15. UNIVERSAL SERIAL BUS CONTROLLER (USB0) .....</b>	<b>143</b>
15.1. Endpoint Addressing .....	144
15.2. USB Transceiver .....	144
15.3. USB Register Access.....	146
15.4. USB Clock Configuration .....	150
15.5. FIFO Management.....	151
15.5.1. FIFO Split Mode.....	151
15.5.2. FIFO Double Buffering .....	151
15.5.3. FIFO Access .....	152
15.6. Function Addressing.....	153
15.7. Function Configuration and Control .....	154
15.8. Interrupts .....	157
15.9. The Serial Interface Engine .....	161
15.10. Endpoint0.....	161
15.10.1. Endpoint0 SETUP Transactions .....	162
15.10.2. Endpoint0 IN Transactions .....	162
15.10.3. Endpoint0 OUT Transactions .....	163
15.11. Configuring Endpoints1-3 .....	166
15.12. Controlling Endpoints1-3 IN .....	166
15.12.1. Endpoints1-3 IN Interrupt or Bulk Mode .....	166
15.12.2. Endpoints1-3 IN Isochronous Mode.....	167
15.13. Controlling Endpoints1-3 OUT .....	170
15.13.1. Endpoints1-3 OUT Interrupt or Bulk Mode .....	170
15.13.2. Endpoints1-3 OUT Isochronous Mode.....	170
<b>16. SMBUS.....</b>	<b>175</b>
16.1. Supporting Documents .....	176
16.2. SMBus Configuration.....	176
16.3. SMBus Operation .....	177
16.3.1. Arbitration.....	177
16.3.2. Clock Low Extension.....	178
16.3.3. SCL Low Timeout .....	178
16.3.4. SCL High (SMBus Free) Timeout.....	178
16.4. Using the SMBus.....	179
16.4.1. SMBus Configuration Register.....	180
16.4.2. SMB0CN Control Register.....	183
16.4.3. Data Register.....	186
16.5. SMBus Transfer Modes.....	187
16.5.1. Master Transmitter Mode .....	187
16.5.2. Master Receiver Mode.....	188
16.5.3. Slave Receiver Mode .....	189
16.5.4. Slave Transmitter Mode.....	190
16.6. SMBus Status Decoding.....	191
<b>17. UART0 .....</b>	<b>193</b>

# C8051F320/1

---

17.1. Enhanced Baud Rate Generation.....	194
17.2. Operational Modes .....	195
17.2.1. 8-Bit UART .....	195
17.2.2. 9-Bit UART .....	196
17.3. Multiprocessor Communications.....	197
<b>18. ENHANCED SERIAL PERIPHERAL INTERFACE (SPI0).....</b>	<b>203</b>
18.1. Signal Descriptions.....	204
18.1.1. Master Out, Slave In (MOSI) .....	204
18.1.2. Master In, Slave Out (MISO) .....	204
18.1.3. Serial Clock (SCK) .....	204
18.1.4. Slave Select (NSS).....	204
18.2. SPI0 Master Mode Operation .....	205
18.3. SPI0 Slave Mode Operation .....	207
18.4. SPI0 Interrupt Sources.....	207
18.5. Serial Clock Timing .....	208
18.6. SPI Special Function Registers .....	210
<b>19. TIMERS .....</b>	<b>217</b>
19.1. Timer 0 and Timer 1 .....	217
19.1.1. Mode 0: 13-bit Counter/Timer.....	217
19.1.2. Mode 1: 16-bit Counter/Timer.....	218
19.1.3. Mode 2: 8-bit Counter/Timer with Auto-Reload.....	219
19.1.4. Mode 3: Two 8-bit Counter/Timers (Timer 0 Only) .....	220
19.2. Timer 2 .....	225
19.2.1. 16-bit Timer with Auto-Reload .....	225
19.2.2. 8-bit Timers with Auto-Reload.....	226
19.2.3. USB Start-of-Frame Capture .....	227
19.3. Timer 3 .....	230
19.3.1. 16-bit Timer with Auto-Reload .....	230
19.3.2. 8-bit Timers with Auto-Reload.....	231
19.3.3. USB Start-of-Frame Capture .....	232
<b>20. PROGRAMMABLE COUNTER ARRAY (PCA0) .....</b>	<b>235</b>
20.1. PCA Counter/Timer.....	236
20.2. Capture/Compare Modules.....	237
20.2.1. Edge-triggered Capture Mode .....	238
20.2.2. Software Timer (Compare) Mode.....	239
20.2.3. High Speed Output Mode .....	240
20.2.4. Frequency Output Mode .....	241
20.2.5. 8-Bit Pulse Width Modulator Mode .....	242
20.2.6. 16-Bit Pulse Width Modulator Mode .....	244
20.3. Watchdog Timer Mode.....	246
20.3.1. Watchdog Timer Operation .....	246
20.3.2. Watchdog Timer Usage .....	247
20.4. Register Descriptions for PCA .....	248
<b>21. C2 INTERFACE .....</b>	<b>253</b>
21.1. C2 Interface Registers .....	253

---

---

21.2.C2 Pin Sharing.....255

*Notes*



## LIST OF FIGURES AND TABLES

<b>1. SYSTEM OVERVIEW .....</b>	<b>17</b>
Table 1.1. Product Selection Guide.....	17
Figure 1.1. C8051F320 Block Diagram.....	18
Figure 1.2. C8051F321 Block Diagram.....	19
Figure 1.3. Comparison of Peak MCU Execution Speeds.....	20
Figure 1.4. On-Chip Clock and Reset.....	21
Figure 1.5. On-Board Memory Map.....	22
Figure 1.6. USB Controller Block Diagram .....	23
Figure 1.7. Development/In-System Debug Diagram .....	24
Figure 1.8. Digital Crossbar Diagram.....	25
Figure 1.9. PCA Block Diagram.....	26
Figure 1.10. PCA Block Diagram.....	26
Figure 1.11. 10-Bit ADC Block Diagram.....	27
Figure 1.12. Comparator0 Block Diagram .....	28
<b>2. ABSOLUTE MAXIMUM RATINGS .....</b>	<b>29</b>
Table 2.1. Absolute Maximum Ratings*.....	29
<b>3. GLOBAL DC ELECTRICAL CHARACTERISTICS .....</b>	<b>30</b>
Table 3.1. Global DC Electrical Characteristics.....	30
<b>4. PINOUT AND PACKAGE DEFINITIONS .....</b>	<b>31</b>
Table 4.1. Pin Definitions for the C8051F320/1 .....	31
Figure 4.1. LQFP-32 Pinout Diagram (Top View).....	33
Figure 4.2. LQFP-32 Package Diagram.....	34
Table 4.2. LQFP-32 Package Dimensions.....	34
Figure 4.3. MLP-28 Pinout Diagram (Top View) .....	35
Figure 4.4. MLP-28 Package Drawing .....	36
Table 4.3. MLP-28 Package Dimensions .....	36
Figure 4.5. Typical MLP-28 Landing Diagram .....	37
Figure 4.6. Typical MLP-28 Solder Mask .....	38
<b>5. 10-BIT ADC (ADC0) .....</b>	<b>39</b>
Figure 5.1. ADC0 Functional Block Diagram .....	39
Figure 5.2. Typical Temperature Sensor Transfer Function.....	41
Figure 5.3. 10-Bit ADC Track and Conversion Example Timing.....	43
Figure 5.4. ADC0 Equivalent Input Circuits .....	44
Figure 5.5. AMX0P: AMUX0 Positive Channel Select Register.....	45
Figure 5.6. AMX0N: AMUX0 Negative Channel Select Register.....	46
Figure 5.7. ADC0CF: ADC0 Configuration Register .....	47
Figure 5.8. ADC0H: ADC0 Data Word MSB Register.....	47
Figure 5.9. ADC0L: ADC0 Data Word LSB Register .....	48
Figure 5.10. ADC0CN: ADC0 Control Register.....	49
Figure 5.11. ADC0GTH: ADC0 Greater-Than Data High Byte Register.....	50
Figure 5.12. ADC0GTL: ADC0 Greater-Than Data Low Byte Register.....	50
Figure 5.13. ADC0LTH: ADC0 Less-Than Data High Byte Register.....	51
Figure 5.14. ADC0LTL: ADC0 Less-Than Data Low Byte Register .....	51

---

Figure 5.15. ADC Window Compare Example: Right-Justified Single-Ended Data	52
Figure 5.16. ADC Window Compare Example: Left-Justified Single-Ended Data	52
Figure 5.17. ADC Window Compare Example: Right-Justified Differential Data	53
Figure 5.18. ADC Window Compare Example: Left-Justified Differential Data	53
Table 5.1. ADC0 Electrical Characteristics	54
<b>6. VOLTAGE REFERENCE</b>	<b>55</b>
Figure 6.1. Voltage Reference Functional Block Diagram	55
Figure 6.2. REF0CN: Reference Control Register	56
Table 6.1. Voltage Reference Electrical Characteristics	56
<b>7. COMPARATORS</b>	<b>57</b>
Figure 7.1. Comparator0 Functional Block Diagram	57
Figure 7.2. Comparator1 Functional Block Diagram	58
Figure 7.3. Comparator Hysteresis Plot	59
Figure 7.4. CPT0CN: Comparator0 Control Register	60
Figure 7.5. CPT0MX: Comparator0 MUX Selection Register	61
Figure 7.6. CPT0MD: Comparator0 Mode Selection Register	62
Figure 7.7. CPT1CN: Comparator1 Control Register	63
Figure 7.8. CPT1MX: Comparator1 MUX Selection Register	64
Figure 7.9. CPT1MD: Comparator1 Mode Selection Register	65
Table 7.1. Comparator Electrical Characteristics	66
<b>8. VOLTAGE REGULATOR (REG0)</b>	<b>67</b>
Table 8.1. Voltage Regulator Electrical Specifications	69
Figure 8.1. REG0 Configuration: USB Bus-Powered	70
Figure 8.2. REG0 Configuration: USB Self-Powered	70
Figure 8.3. REG0 Configuration: USB Self-Powered, Regulator Disabled	71
Figure 8.4. REG0 Configuration: No USB Connection	71
Figure 8.5. REG0CN: Voltage Regulator Control	72
<b>9. CIP-51 MICROCONTROLLER</b>	<b>73</b>
Figure 9.1. CIP-51 Block Diagram	73
Table 9.1. CIP-51 Instruction Set Summary	75
Figure 9.2. Memory Map	79
Table 9.2. Special Function Register (SFR) Memory Map	81
Table 9.3. Special Function Registers	81
Figure 9.3. DPL: Data Pointer Low Byte	84
Figure 9.4. DPH: Data Pointer High Byte	84
Figure 9.5. SP: Stack Pointer	85
Figure 9.6. PSW: Program Status Word	85
Figure 9.7. ACC: Accumulator	86
Figure 9.8. B: B Register	86
Table 9.4. Interrupt Summary	89
Figure 9.9. IE: Interrupt Enable	90
Figure 9.10. IP: Interrupt Priority	91
Figure 9.11. EIE1: Extended Interrupt Enable 1	92
Figure 9.12. EIP1: Extended Interrupt Priority 1	93
Figure 9.13. EIE2: Extended Interrupt Enable 2	94

---

Figure 9.14. EIP2: Extended Interrupt Priority 2.....	94
Figure 9.15. IT01CF: INT0/INT1 Configuration Register.....	95
Figure 9.16. PCON: Power Control Register.....	97
<b>10. RESET SOURCES .....</b>	<b>99</b>
Figure 10.1. Reset Sources.....	99
Figure 10.2. Power-On and VDD Monitor Reset Timing.....	100
Figure 10.3. VDM0CN: VDD Monitor Control.....	101
Figure 10.4. RSTSRC: Reset Source Register.....	104
Table 10.1. Reset Electrical Characteristics.....	105
<b>11. FLASH MEMORY .....</b>	<b>107</b>
Table 11.1. FLASH Electrical Characteristics.....	108
Figure 11.1. FLASH Program Memory Map and Security Byte.....	110
Figure 11.2. PSCTL: Program Store R/W Control.....	110
Figure 11.3. FLKEY: FLASH Lock and Key Register.....	111
Figure 11.4. FLSC: FLASH Scale Register.....	111
<b>12. EXTERNAL RAM .....</b>	<b>113</b>
Figure 12.1. External Ram Memory Map.....	113
Figure 12.2. XRAM Memory Map Expanded View.....	114
Figure 12.3. EMI0CN: External Memory Interface Control.....	115
<b>13. OSCILLATORS .....</b>	<b>117</b>
Figure 13.1. Oscillator Diagram.....	117
Figure 13.2. OSCICN: Internal Oscillator Control Register.....	119
Figure 13.3. OSCICL: Internal Oscillator Calibration Register.....	119
Figure 13.4. OSCXCN: External Oscillator Control Register.....	122
Figure 13.5. CLKMUL: Clock Multiplier Control Register.....	123
Table 13.1. Typical USB Full Speed Clock Settings.....	124
Table 13.2. Typical USB Low Speed Clock Settings.....	124
Figure 13.6. CLKSEL: Clock Select Register.....	125
Table 13.3. Internal Oscillator Electrical Characteristics.....	126
<b>14. PORT INPUT/OUTPUT .....</b>	<b>127</b>
Figure 14.1. Port I/O Functional Block Diagram.....	127
Figure 14.2. Port I/O Cell Block Diagram.....	128
Figure 14.3. Crossbar Priority Decoder with No Pins Skipped.....	129
Figure 14.4. Crossbar Priority Decoder with Crystal Pins Skipped.....	130
Figure 14.5. XBR0: Port I/O Crossbar Register 0.....	132
Figure 14.6. XBR1: Port I/O Crossbar Register 1.....	133
Figure 14.7. P0: Port0 Register.....	135
Figure 14.8. P0MDIN: Port0 Input Mode Register.....	135
Figure 14.9. P0MDOUT: Port0 Output Mode Register.....	136
Figure 14.10. P0SKIP: Port0 Skip Register.....	136
Figure 14.11. P1: Port1 Register.....	137
Figure 14.12. P1MDIN: Port1 Input Mode Register.....	137
Figure 14.13. P1MDOUT: Port1 Output Mode Register.....	138
Figure 14.14. P1SKIP: Port1 Skip Register.....	138
Figure 14.15. P2: Port2 Register.....	139

Figure 14.16. P2MDIN: Port2 Input Mode Register .....	139
Figure 14.17. P2MDOUT: Port2 Output Mode Register.....	140
Figure 14.18. P2SKIP: Port2 Skip Register.....	140
Figure 14.19. P3: Port3 Register.....	141
Figure 14.20. P3MDIN: Port3 Input Mode Register .....	141
Figure 14.21. P3MDOUT: Port3 Output Mode Register.....	142
Table 14.1. Port I/O DC Electrical Characteristics .....	142
<b>15. UNIVERSAL SERIAL BUS CONTROLLER (USB0) .....</b>	<b>143</b>
Figure 15.1. USB0 Block Diagram.....	143
Table 15.1. Endpoint Addressing Scheme.....	144
Figure 15.2. USB0XCN: USB0 Transceiver Control.....	145
Figure 15.3. USB0 Register Access Scheme.....	146
Figure 15.4. USB0ADR: USB0 Indirect Address Register .....	147
Figure 15.5. USB0DAT: USB0 Data Register .....	148
Figure 15.6. INDEX: USB0 Endpoint Index (USB Register) .....	148
Table 15.2. USB0 Controller Registers.....	149
Figure 15.7. CLKREC: Clock Recovery Control (USB Register) .....	150
Figure 15.8. USB FIFO Allocation.....	151
Table 15.3. FIFO Configurations .....	152
Figure 15.9. FIFOn: USB0 Endpoint FIFO Access (USB Registers) .....	152
Figure 15.10. FADDR: USB0 Function Address (USB Register) .....	153
Figure 15.11. POWER: USB0 Power (USB Register) .....	155
Figure 15.12. FRAMEL: USB0 Frame Number Low (USB Register) .....	156
Figure 15.13. FRAMEH: USB0 Frame Number High (USB Register) .....	156
Figure 15.14. IN1INT: USB0 IN Endpoint Interrupt (USB Register).....	157
Figure 15.15. OUT1INT: USB0 Out Endpoint Interrupt (USB Register).....	158
Figure 15.16. CMINT: USB0 Common Interrupt (USB Register).....	159
Figure 15.17. IN1IE: USB0 IN Endpoint Interrupt Enable (USB Register) .....	160
Figure 15.18. OUT1IE: USB0 Out Endpoint Interrupt Enable (USB Register).....	160
Figure 15.19. CMIE: USB0 Common Interrupt Enable (USB Register) .....	161
Figure 15.20. E0CSR: USB0 Endpoint0 Control (USB Register) .....	164
Figure 15.21. E0CNT: USB0 Endpoint 0 Data Count (USB Register).....	165
Figure 15.22. E1NCSRL: USB0 IN Endpoint Control High Byte (USB Register) .....	168
Figure 15.23. E1NCSRH: USB0 IN Endpoint Control Low Byte (USB Register) .....	169
Figure 15.24. E0UTCSRL: USB0 OUT Endpoint Control High Byte (USB Register) .....	171
Figure 15.25. E0UTCSRH: USB0 OUT Endpoint Control Low Byte (USB Register) .....	172
Figure 15.26. E0UTCNTL: USB0 OUT Endpoint Count Low (USB Register) .....	172
Figure 15.27. E0UTCNTH: USB0 OUT Endpoint Count High (USB Register) .....	172
Table 15.4. USB Transceiver Electrical Characteristics .....	173
<b>16. SMBUS .....</b>	<b>175</b>
Figure 16.1. SMBus Block Diagram .....	175
Figure 16.2. Typical SMBus Configuration .....	176
Figure 16.3. SMBus Transaction .....	177
Table 16.1. SMBus Clock Source Selection.....	180
Figure 16.4. Typical SMBus SCL Generation.....	181

Table 16.2. Minimum SDA Setup and Hold Times .....	181
Figure 16.5. SMB0CF: SMBus Clock/Configuration Register .....	182
Figure 16.6. SMB0CN: SMBus Control Register .....	184
Table 16.3. Sources for Hardware Changes to SMB0CN .....	185
Figure 16.7. SMB0DAT: SMBus Data Register .....	186
Figure 16.8. Typical Master Transmitter Sequence.....	187
Figure 16.9. Typical Master Receiver Sequence .....	188
Figure 16.10. Typical Slave Receiver Sequence .....	189
Figure 16.11. Typical Slave Transmitter Sequence.....	190
Table 16.4. SMBus Status Decoding.....	191
<b>17. UART0 .....</b>	<b>193</b>
Figure 17.1. UART0 Block Diagram.....	193
Figure 17.2. UART0 Baud Rate Logic .....	194
Figure 17.3. UART Interconnect Diagram .....	195
Figure 17.4. 8-Bit UART Timing Diagram .....	195
Figure 17.5. 9-Bit UART Timing Diagram .....	196
Figure 17.6. UART Multi-Processor Mode Interconnect Diagram .....	197
Figure 17.7. SCON0: Serial Port 0 Control Register.....	198
Figure 17.8. SBUF0: Serial (UART0) Port Data Buffer Register .....	199
Table 17.1. Timer Settings for Standard Baud Rates Using The Internal Oscillator .....	200
Table 17.2. Timer Settings for Standard Baud Rates Using an External Oscillator.....	200
Table 17.3. Timer Settings for Standard Baud Rates Using an External Oscillator.....	201
Table 17.4. Timer Settings for Standard Baud Rates Using an External Oscillator.....	201
Table 17.5. Timer Settings for Standard Baud Rates Using an External Oscillator.....	202
Table 17.6. Timer Settings for Standard Baud Rates Using an External Oscillator.....	202
<b>18. ENHANCED SERIAL PERIPHERAL INTERFACE (SPI0) .....</b>	<b>203</b>
Figure 18.1. SPI Block Diagram.....	203
Figure 18.2. Multiple-Master Mode Connection Diagram .....	206
Figure 18.3. 3-Wire Single Master and 3-Wire Single Slave Mode Connection Diagram ...	206
Figure 18.4. 4-Wire Single Master Mode and 4-Wire Slave Mode Connection Diagram ...	206
Figure 18.5. Master Mode Data/Clock Timing.....	208
Figure 18.6. Slave Mode Data/Clock Timing (CKPHA = 0) .....	209
Figure 18.7. Slave Mode Data/Clock Timing (CKPHA = 1) .....	209
Figure 18.8. SPI0CFG: SPI0 Configuration Register.....	210
Figure 18.9. SPI0CN: SPI0 Control Register .....	211
Figure 18.10. SPI0CKR: SPI0 Clock Rate Register .....	212
Figure 18.11. SPI0DAT: SPI0 Data Register .....	213
Figure 18.12. SPI Master Timing (CKPHA = 0).....	214
Figure 18.13. SPI Master Timing (CKPHA = 1).....	214
Figure 18.14. SPI Slave Timing (CKPHA = 0) .....	215
Figure 18.15. SPI Slave Timing (CKPHA = 1) .....	215
Table 18.1. SPI Slave Timing Parameters.....	216
<b>19. TIMERS .....</b>	<b>217</b>
Figure 19.1. T0 Mode 0 Block Diagram.....	218
Figure 19.2. T0 Mode 2 Block Diagram.....	219

Figure 19.3. T0 Mode 3 Block Diagram.....	220
Figure 19.4. TCON: Timer Control Register.....	221
Figure 19.5. TMOD: Timer Mode Register.....	222
Figure 19.6. CKCON: Clock Control Register.....	223
Figure 19.7. TL0: Timer 0 Low Byte .....	224
Figure 19.8. TL1: Timer 1 Low Byte .....	224
Figure 19.9. TH0: Timer 0 High Byte .....	224
Figure 19.10. TH1: Timer 1 High Byte .....	224
Figure 19.11. Timer 2 16-Bit Mode Block Diagram .....	225
Figure 19.12. Timer 2 8-Bit Mode Block Diagram .....	226
Figure 19.13. Timer 2 SOF Capture Mode (T2SPLIT = ‘0’) .....	227
Figure 19.14. Timer 2 SOF Capture Mode (T2SPLIT = ‘1’) .....	227
Figure 19.15. TMR2CN: Timer 2 Control Register .....	228
Figure 19.16. TMR2RLL: Timer 2 Reload Register Low Byte .....	229
Figure 19.17. TMR2RLH: Timer 2 Reload Register High Byte .....	229
Figure 19.18. TMR2L: Timer 2 Low Byte .....	229
Figure 19.19. TMR2H Timer 2 High Byte .....	229
Figure 19.20. Timer 3 16-Bit Mode Block Diagram .....	230
Figure 19.21. Timer 3 8-Bit Mode Block Diagram .....	231
Figure 19.22. Timer 3 SOF Capture Mode (T3SPLIT = ‘0’) .....	232
Figure 19.23. Timer 3 SOF Capture Mode (T3SPLIT = ‘1’) .....	232
Figure 19.24. TMR3CN: Timer 3 Control Register .....	233
Figure 19.25. TMR3RLL: Timer 3 Reload Register Low Byte .....	234
Figure 19.26. TMR3RLH: Timer 3 Reload Register High Byte .....	234
Figure 19.27. TMR3L: Timer 3 Low Byte .....	234
Figure 19.28. TMR3H Timer 3 High Byte .....	234
<b>20. PROGRAMMABLE COUNTER ARRAY (PCA) .....</b>	<b>235</b>
Figure 20.1. PCA Block Diagram.....	235
Figure 20.2. PCA Counter/Timer Block Diagram.....	236
Table 20.1. PCA Timebase Input Options.....	236
Figure 20.3. PCA Interrupt Block Diagram.....	237
Table 20.2. PCA0CPM Register Settings for PCA Capture/Compare Modules.....	237
Figure 20.4. PCA Capture Mode Diagram .....	238
Figure 20.5. PCA Software Timer Mode Diagram.....	239
Figure 20.6. PCA High Speed Output Mode Diagram.....	240
Figure 20.7. PCA Frequency Output Mode.....	241
Figure 20.8. PCA 8-Bit PWM Mode Diagram .....	243
Figure 20.9. PCA 16-Bit PWM Mode .....	244
Figure 20.10. PCA Module 4 with Watchdog Timer Enabled .....	246
Table 20.3. Watchdog Timer Timeout Intervals† .....	247
Figure 20.11. PCA0CN: PCA Control Register .....	248
Figure 20.12. PCA0MD: PCA Mode Register .....	249
Figure 20.13. PCA0CPMn: PCA Capture/Compare Mode Registers .....	250
Figure 20.14. PCA0L: PCA Counter/Timer Low Byte .....	251
Figure 20.15. PCA0H: PCA Counter/Timer High Byte .....	251

---

Figure 20.16. PCA0CPLn: PCA Capture Module Low Byte .....	252
Figure 20.17. PCA0CPHn: PCA Capture Module High Byte .....	252
<b>21. C2 INTERFACE .....</b>	<b>253</b>
Figure 21.1. C2ADD: C2 Address Register .....	253
Figure 21.2. DEVICEID: C2 Device ID Register .....	253
Figure 21.3. REVID: C2 Revision ID Register .....	254
Figure 21.4. FPCTL: C2 FLASH Programming Control Register .....	254
Figure 21.5. FPDAT: C2 FLASH Programming Data Register .....	254
Figure 21.6. Typical C2 Pin Sharing .....	255

*Notes*



## 1. SYSTEM OVERVIEW

C8051F320/1 devices are fully integrated mixed-signal System-on-a-Chip MCUs. Highlighted features are listed below. Refer to Table 1.1 for specific product feature selection.

- High-speed pipelined 8051-compatible microcontroller core (up to 25 MIPS)
- In-system, full-speed, non-intrusive debug interface (on-chip)
- Universal Serial Bus (USB) Function Controller with eight flexible endpoint pipes, integrated transceiver, and 1k FIFO RAM
- Supply Voltage Regulator (5V-to-3V)
- True 10-bit 200 kbps 17-channel single-ended/differential ADC with analog multiplexer
- On-chip Voltage Reference and Temperature Sensor
- On-chip Voltage Comparators (2)
- Precision programmable 12 MHz internal oscillator and 4x clock multiplier
- 16k bytes of on-chip FLASH memory
- 2304 total bytes of on-chip RAM (256 + 1k + 1k USB FIFO)
- SMBus/I<sup>2</sup>C, Enhanced UART, and Enhanced SPI serial interfaces implemented in hardware
- Four general-purpose 16-bit timers
- Programmable Counter/Timer Array (PCA) with five capture/compare modules and Watchdog Timer function
- On-chip Power-On Reset, VDD Monitor, and Missing Clock Detector
- 25/21 Port I/O (5V tolerant)

With on-chip Power-On Reset, VDD monitor, Voltage Regulator, Watchdog Timer, and clock oscillator, C8051F320/1 devices are truly stand-alone System-on-a-Chip solutions. The FLASH memory can be reprogrammed in-circuit, providing non-volatile data storage, and also allowing field upgrades of the 8051 firmware. User software has complete control of all peripherals, and may individually shut down any or all peripherals for power savings.

The on-chip Silicon Labs 2-Wire (C2) Development Interface allows non-intrusive (uses no on-chip resources), full speed, in-circuit debugging using the production MCU installed in the final application. This debug logic supports inspection and modification of memory and registers, setting breakpoints, single stepping, run and halt commands. All analog and digital peripherals are fully functional while debugging using C2. The two C2 interface pins can be shared with user functions, allowing in-system debugging without occupying package pins.

Each device is specified for 2.7 V-to-3.6 V operation over the industrial temperature range (-40°C to +85°C). (Note that 3.0 V-to-3.6 V is required for USB communication.) The Port I/O and /RST pins are tolerant of input signals up to 5 V. C8051F320/1 are available in a 32-pin LQFP or a 28-pin MLP package.

**Table 1.1. Product Selection Guide**

	MIPS (Peak)	FLASH Memory	RAM	Calibrated Internal Oscillator	USB	Supply Voltage Regulator	SMBus/I <sup>2</sup> C	Enhanced SPI	UART	Timers (16-bit)	Programmable Counter Array	Digital Port I/Os	10-bit 200kps ADC	Temperature Sensor	Voltage Reference	Analog Comparators	Package
C8051F320	25	16k	2304	✓	✓	✓	✓	✓	✓	4	✓	25	✓	✓	✓	2	LQFP-32
C8051F321	25	16k	2304	✓	✓	✓	✓	✓	✓	4	✓	21	✓	✓	✓	2	MLP-28

# C8051F320/1

Figure 1.1. C8051F320 Block Diagram

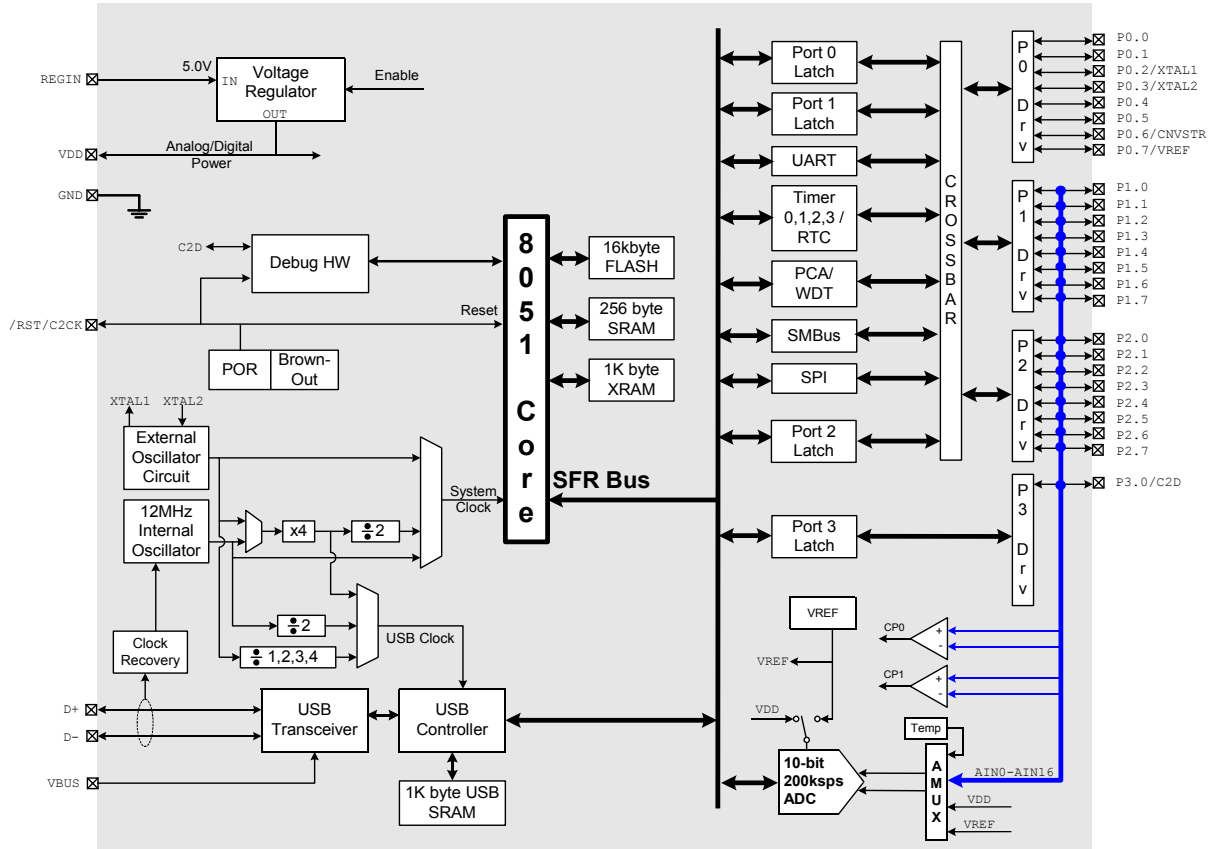
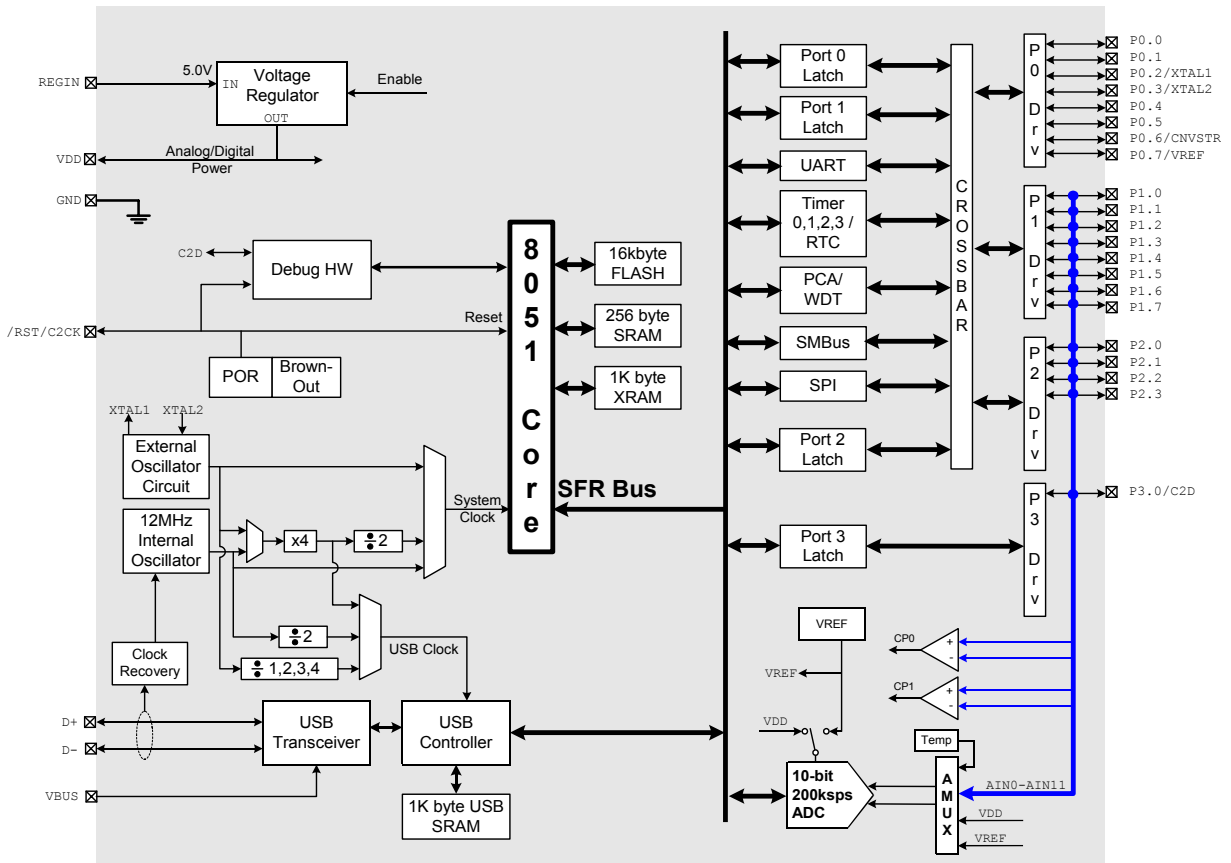


Figure 1.2. C8051F321 Block Diagram



# C8051F320/1

## 1.1. CIP-51™ Microcontroller Core

### 1.1.1. Fully 8051 Compatible

The C8051F320/1 family utilizes Silicon Labs' proprietary CIP-51 microcontroller core. The CIP-51 is fully compatible with the MCS-51™ instruction set; standard 803x/805x assemblers and compilers can be used to develop software. The CIP-51 core offers all the peripherals included with a standard 8051, including four 16-bit counter/timers, a full-duplex UART with extended baud rate configuration, an enhanced SPI port, 2304 bytes of on-chip RAM, 128 byte Special Function Register (SFR) address space, and 25/21 I/O pins.

### 1.1.2. Improved Throughput

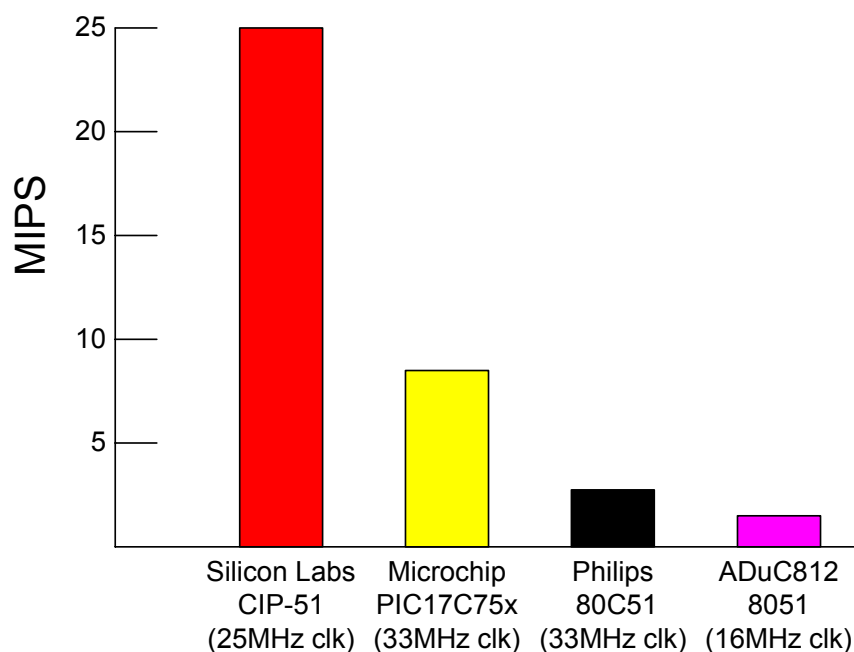
The CIP-51 employs a pipelined architecture that greatly increases its instruction throughput over the standard 8051 architecture. In a standard 8051, all instructions except for MUL and DIV take 12 or 24 system clock cycles to execute with a maximum system clock of 12-to-24 MHz. By contrast, the CIP-51 core executes 70% of its instructions in one or two system clock cycles, with only four instructions taking more than four system clock cycles.

The CIP-51 has a total of 109 instructions. The table below shows the total number of instructions that require each execution time.

Clocks to Execute	1	2	2/3	3	3/4	4	4/5	5	8
Number of Instructions	26	50	5	14	7	3	1	2	1

With the CIP-51's maximum system clock at 25 MHz, it has a peak throughput of 25 MIPS. Figure 1.3 shows a comparison of peak throughputs for various 8-bit microcontroller cores with their maximum system clocks.

**Figure 1.3. Comparison of Peak MCU Execution Speeds**



## 1.1.3. Additional Features

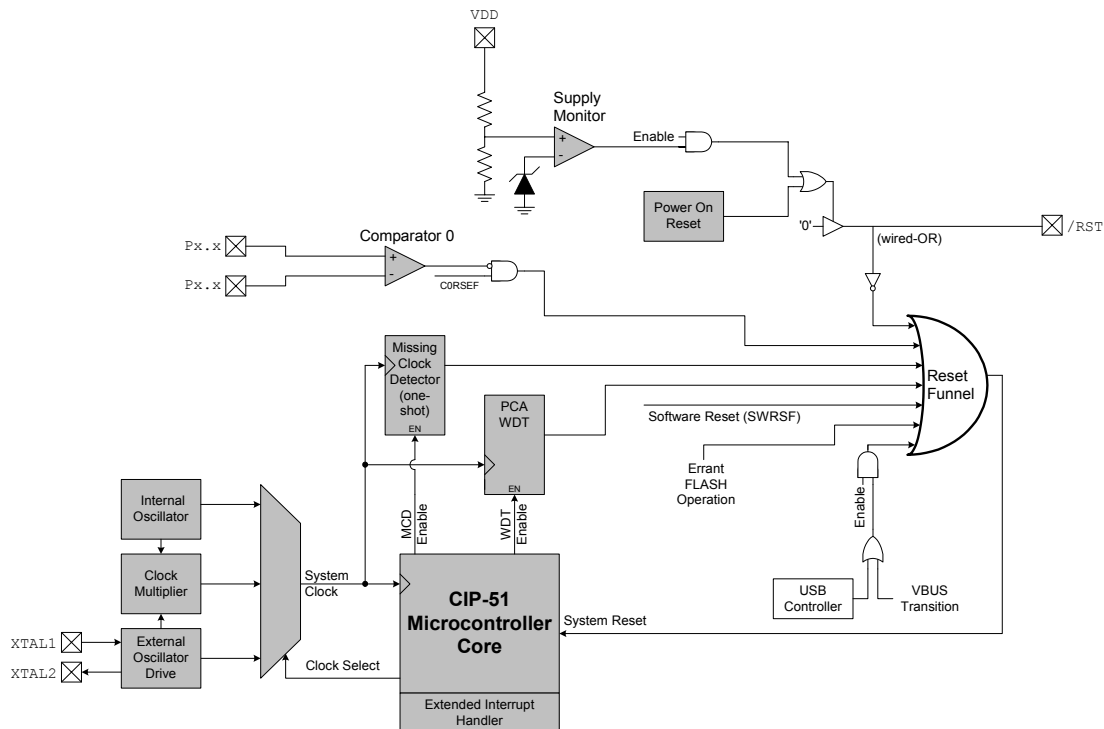
The C8051F320/1 SoC family includes several key enhancements to the CIP-51 core and peripherals to improve performance and ease of use in end applications.

The extended interrupt handler provides 16 interrupt sources into the CIP-51 (as opposed to 7 for the standard 8051), allowing numerous analog and digital peripherals to interrupt the controller. An interrupt driven system requires less intervention by the MCU, giving it more effective throughput. The extra interrupt sources are very useful when building multi-tasking, real-time systems.

Nine reset sources are available: power-on reset circuitry (POR), an on-chip VDD monitor (forces reset when power supply voltage drops below  $V_{RST}$  as given in Table 10.1 on page 105), the USB controller (USB bus reset or a VBUS transition), a Watchdog Timer, a Missing Clock Detector, a voltage level detection from Comparator0, a forced software reset, an external reset pin, and an errant FLASH read/write protection circuit. Each reset source except for the POR, Reset Input Pin, or FLASH error may be disabled by the user in software. The WDT may be permanently enabled in software after a power-on reset during MCU initialization.

The internal oscillator is factory calibrated to 12 MHz  $\pm 1.5\%$ , and the internal oscillator period may be user programmed in  $\sim 0.25\%$  increments. A clock recovery mechanism allows the internal oscillator to be used with the 4x Clock Multiplier as the USB clock source in Full Speed mode; the internal oscillator can also be used as the USB clock source in Low Speed mode. External oscillators may also be used with the 4x Clock Multiplier. An external oscillator drive circuit is also included, allowing an external crystal, ceramic resonator, capacitor, RC, or CMOS clock source to generate the system clock. The system clock may be configured to use the internal oscillator, external oscillator, or the Clock Multiplier output divided by 2. If desired, the system clock source may be switched on-the-fly between oscillator sources. An external oscillator can be extremely useful in low power applications, allowing the MCU to run from a slow (power saving) external clock source, while periodically switching to the internal oscillator as needed.

**Figure 1.4. On-Chip Clock and Reset**



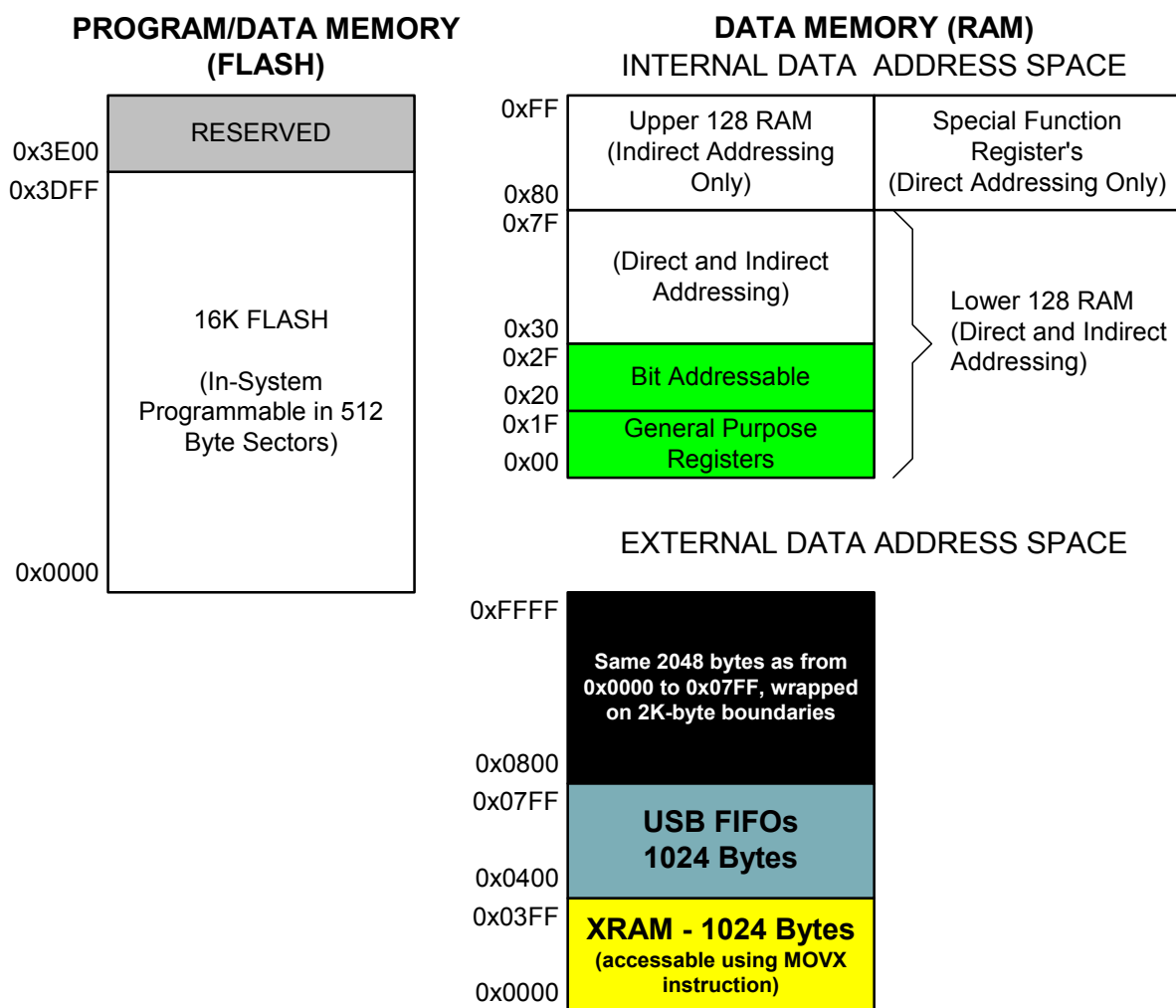
# C8051F320/1

## 1.2. On-Chip Memory

The CIP-51 has a standard 8051 program and data address configuration. It includes 256 bytes of data RAM, with the upper 128 bytes dual-mapped. Indirect addressing accesses the upper 128 bytes of general purpose RAM, and direct addressing accesses the 128 byte SFR address space. The lower 128 bytes of RAM are accessible via direct and indirect addressing. The first 32 bytes are addressable as four banks of general purpose registers, and the next 16 bytes can be byte addressable or bit addressable.

Program memory consists of 16k bytes of FLASH. This memory may be reprogrammed in-system in 512 byte sectors, and requires no special off-chip programming voltage. See Figure 1.5 for the MCU system memory map.

Figure 1.5 On-Board Memory Map



## 1.3. Universal Serial Bus Controller

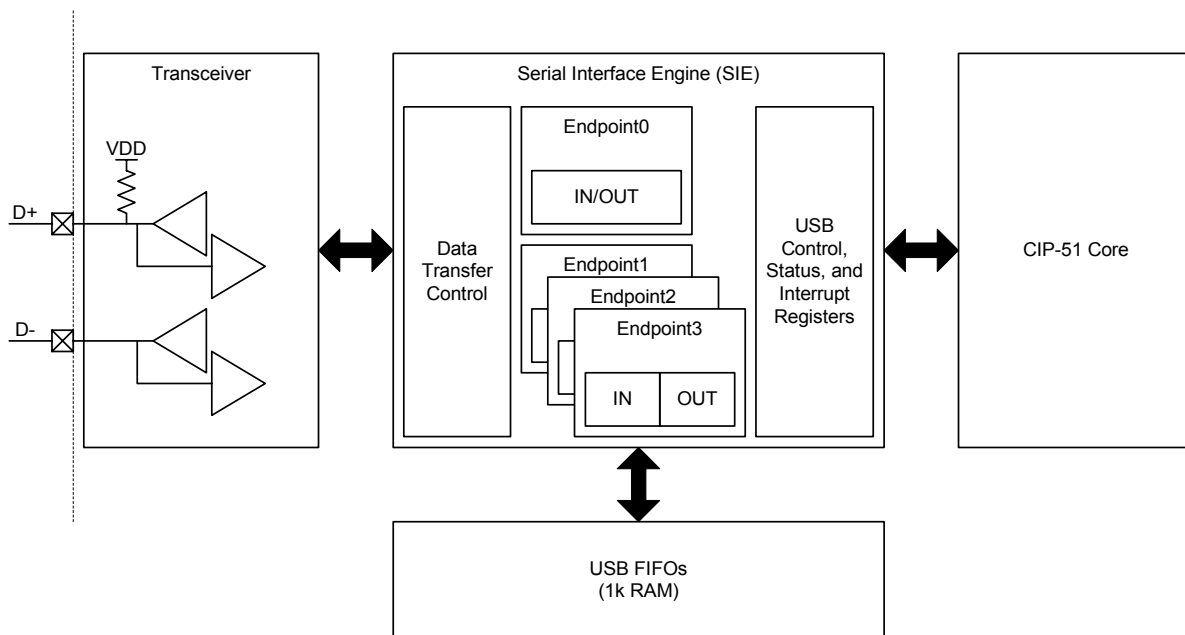
The Universal Serial Bus Controller (USB0) is a USB 2.0 compliant Full or Low Speed function with integrated transceiver and endpoint FIFO RAM. A total of eight endpoint pipes are available: a bi-directional control endpoint (Endpoint0) and three pairs of IN/OUT endpoints (Endpoints1-3 IN/OUT).

A 1k block of XRAM is used as dedicated USB FIFO space. This FIFO space is distributed among Endpoints0-3; Endpoint1-3 FIFO slots can be configured as IN, OUT, or both IN and OUT (split mode). The maximum FIFO size is 512 bytes (Endpoint3).

USB0 can be operated as a Full or Low Speed function. On-chip 4x Clock Multiplier and clock recovery circuitry allow both Full and Low Speed options to be implemented with the on-chip precision oscillator as the USB clock source. An external oscillator source can also be used with the 4x Clock Multiplier to generate the USB clock. The CPU clock source is independent of the USB clock.

The USB Transceiver is USB 2.0 compliant, and includes on-chip matching and pull-up resistors. The pull-up resistors can be enabled/disabled in software, and will appear on the D+ or D- pin according to the software-selected speed setting (Full or Low Speed).

**Figure 1.6. USB Controller Block Diagram**



## 1.4. Voltage Regulator

C8051F320/1 devices include a 5 V-to-3 V voltage regulator (REG0). When enabled, the REG0 output appears on the VDD pin and can be used to power external devices. REG0 can be enabled/disabled by software.

# C8051F320/1

## 1.5. On-Chip Debug Circuitry

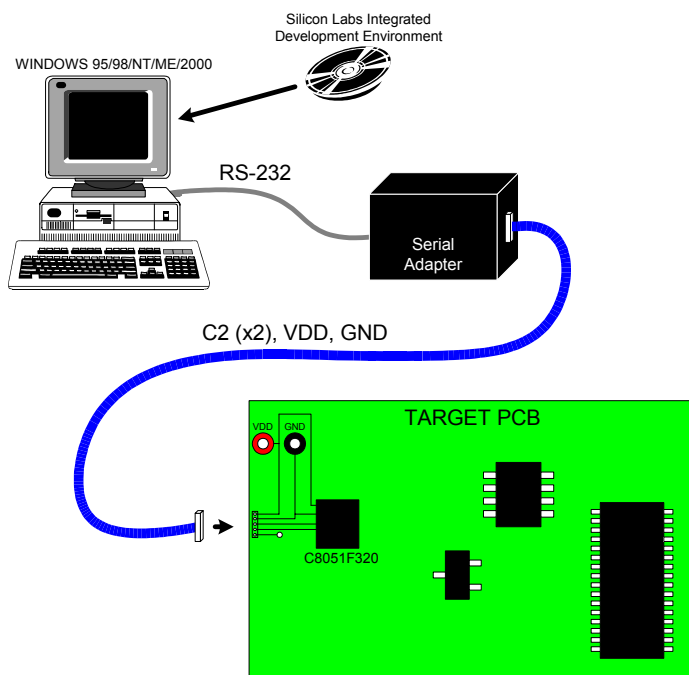
The C8051F320/1 devices include on-chip Silicon Labs 2-Wire (C2) debug circuitry that provides non-intrusive, full speed, in-circuit debugging of the production part *installed in the end application*.

Silicon Labs' debugging system supports inspection and modification of memory and registers, breakpoints, and single stepping. No additional target RAM, program memory, timers, or communications channels are required. All the digital and analog peripherals are functional and work correctly while debugging. All the peripherals (except for the USB, ADC, and SMBus) are stalled when the MCU is halted, during single stepping, or at a breakpoint in order to keep them synchronized.

The C8051F310DK development kit provides all the hardware and software necessary to develop application code and perform in-circuit debugging with the C8051F320/1 MCUs. The kit includes software with a developer's studio and debugger, an integrated 8051 assembler, and an RS-232 to C2 serial adapter. It also has a target application board with the associated MCU installed and prototyping area, plus the RS-232 and C2 cables, and wall-mount power supply. The Development Kit requires a Windows 95/98/NT/ME/2000 computer with one available RS-232 serial port. As shown in Figure 1.7, the PC is connected via RS-232 to the Serial Adapter. A six-inch ribbon cable connects the Serial Adapter to the user's application board, picking up the two C2 pins and VDD and GND. The Serial Adapter takes its power from the application board. For applications where there is not sufficient power available from the target board, the provided power supply can be connected directly to the Serial Adapter.

The Silicon Labs IDE interface is a vastly superior developing and debugging configuration, compared to standard MCU emulators that use on-board "ICE Chips" and require the MCU in the application board to be socketed. Silicon Labs' debug paradigm increases ease of use and preserves the performance of the precision analog peripherals.

**Figure 1.7. Development/In-System Debug Diagram**

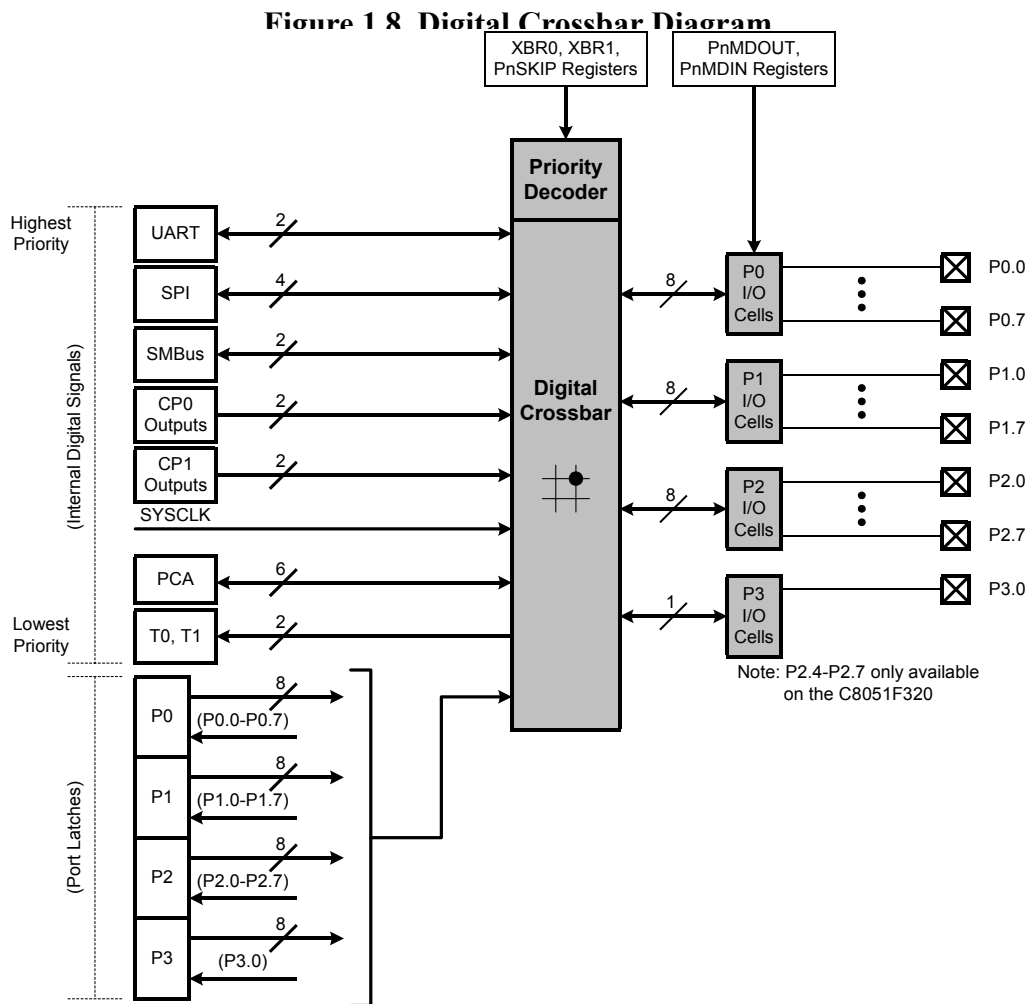




## 1.6. Programmable Digital I/O and Crossbar

C8051F320 devices include 25 I/O pins (three byte-wide Ports and one 1-bit-wide Port); C8051F321 devices include 21 I/O pins (two byte-wide Ports, one 4-bit-wide Port, and one 1-bit-wide Port). The C8051F320/1 Ports behave like typical 8051 Ports with a few enhancements. Each Port pin may be configured as an analog input or a digital I/O pin. Pins selected as digital I/Os may additionally be configured for push-pull or open-drain output. The “weak pull-ups” that are fixed on typical 8051 devices may be globally disabled, providing power savings capabilities.

The Digital Crossbar allows mapping of internal digital system resources to Port I/O pins (See Figure 1.8). On-chip counter/timers, serial buses, HW interrupts, comparator outputs, and other digital signals in the controller can be configured to appear on the Port I/O pins specified in the Crossbar Control registers. This allows the user to select the exact mix of general purpose Port I/O and digital resources needed for the particular application.



## 1.7. Serial Ports

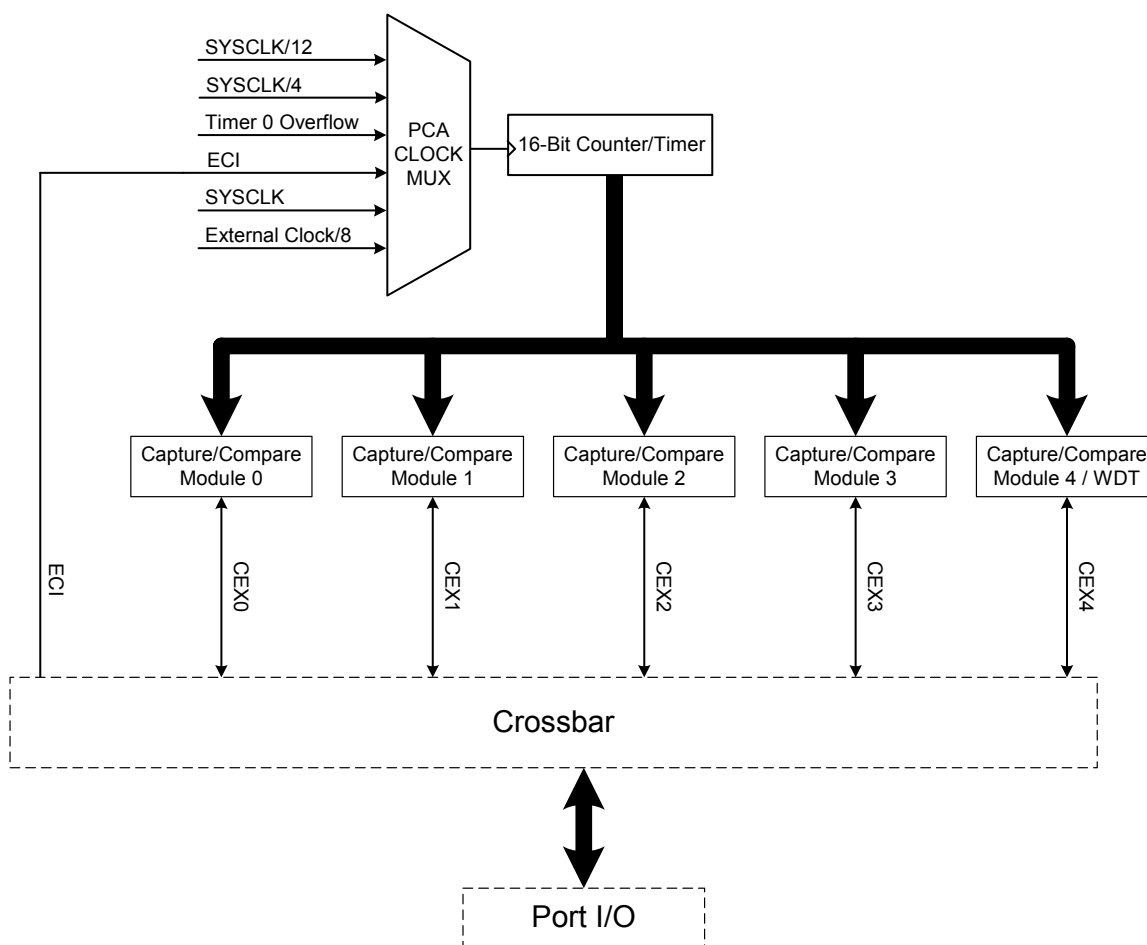
The C8051F320/1 Family includes an SMBus/I<sup>2</sup>C interface, a full-duplex UART with enhanced baud rate configuration, and an Enhanced SPI interface. Each of the serial buses is fully implemented in hardware and makes extensive use of the CIP-51's interrupts, thus requiring very little CPU intervention.

## 1.8. Programmable Counter Array

An on-chip Programmable Counter/Timer Array (PCA) is included in addition to the four 16-bit general purpose counter/timers. The PCA consists of a dedicated 16-bit counter/timer time base with five programmable capture/compare modules. The PCA clock is derived from one of six sources: the system clock divided by 12, the system clock divided by 4, Timer 0 overflows, an External Clock Input (ECI), the system clock, or the external oscillator clock source divided by 8. The external clock source selection is useful for real-time clock functionality, where the PCA is clocked by an external source while the internal oscillator drives the system clock.

Each capture/compare module can be configured to operate in one of six modes: Edge-Triggered Capture, Software Timer, High Speed Output, 8- or 16-bit Pulse Width Modulator, or Frequency Output. Additionally, Capture/Compare Module 4 offers watchdog timer (WDT) capabilities. Following a system reset, Module 4 is configured and enabled in WDT mode. The PCA Capture/Compare Module I/O and External Clock Input may be routed to Port I/O via the Digital Crossbar.

**Figure 1.9. PCA Block Diagram**



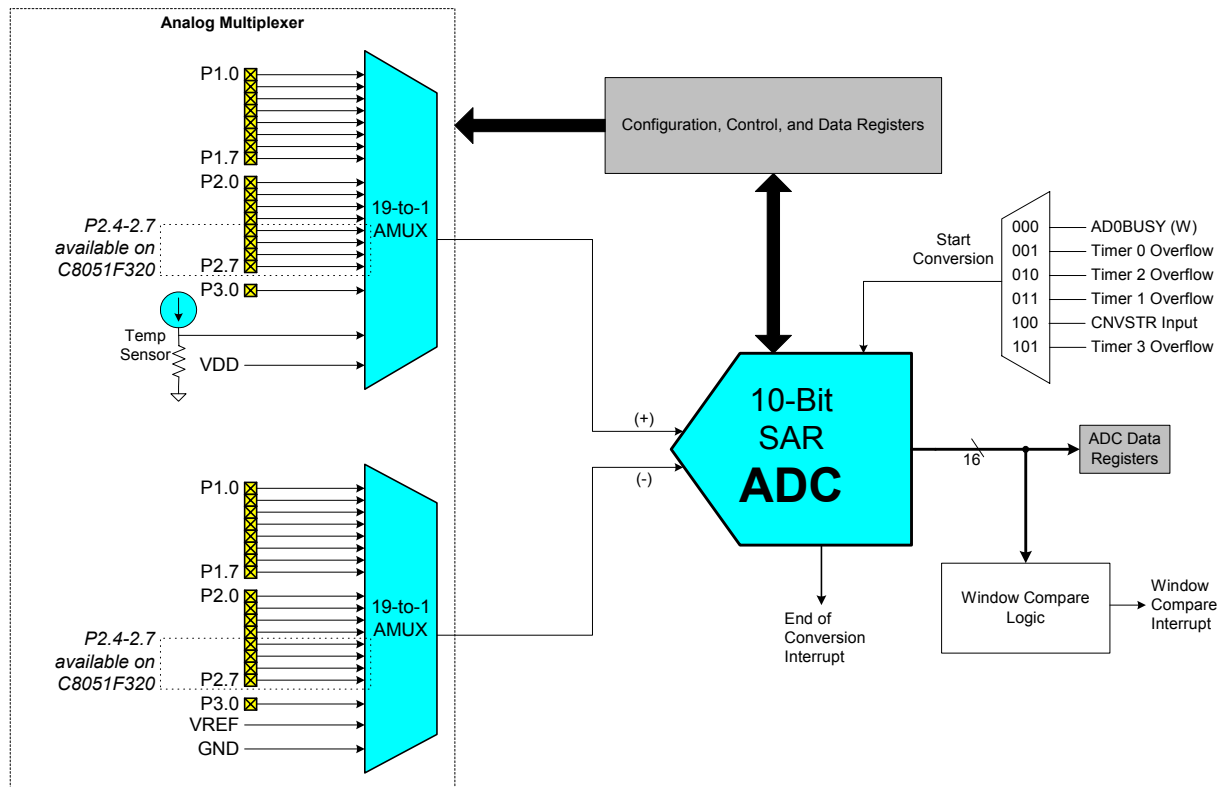
## 1.9. 10-Bit Analog to Digital Converter

The C8051F320/1 devices include an on-chip 10-bit SAR ADC with a 17-channel differential input multiplexer. With a maximum throughput of 200 ksp/s, the ADC offers true 10-bit linearity with an INL of  $\pm 1\text{LSB}$ . The ADC system includes a configurable analog multiplexer that selects both positive and negative ADC inputs. Ports 1-3 are available as ADC inputs; additionally, the on-chip Temperature Sensor output and the power supply voltage (VDD) are available as ADC inputs. User firmware may shut down the ADC to save power.

Conversions can be started in six ways: a software command, an overflow of Timer 0, 1, 2, or 3, or an external convert start signal. This flexibility allows the start of conversion to be triggered by software events, a periodic signal (timer overflows), or external HW signals. Conversion completions are indicated by a status bit and an interrupt (if enabled). The resulting 10-bit data word is latched into the ADC data SFRs upon completion of a conversion.

Window compare registers for the ADC data can be configured to interrupt the controller when ADC data is either within or outside of a specified range. The ADC can monitor a key voltage continuously in background mode, but not interrupt the controller unless the converted data is within/outside the specified range.

**Figure 1.10. 10-Bit ADC Block Diagram**



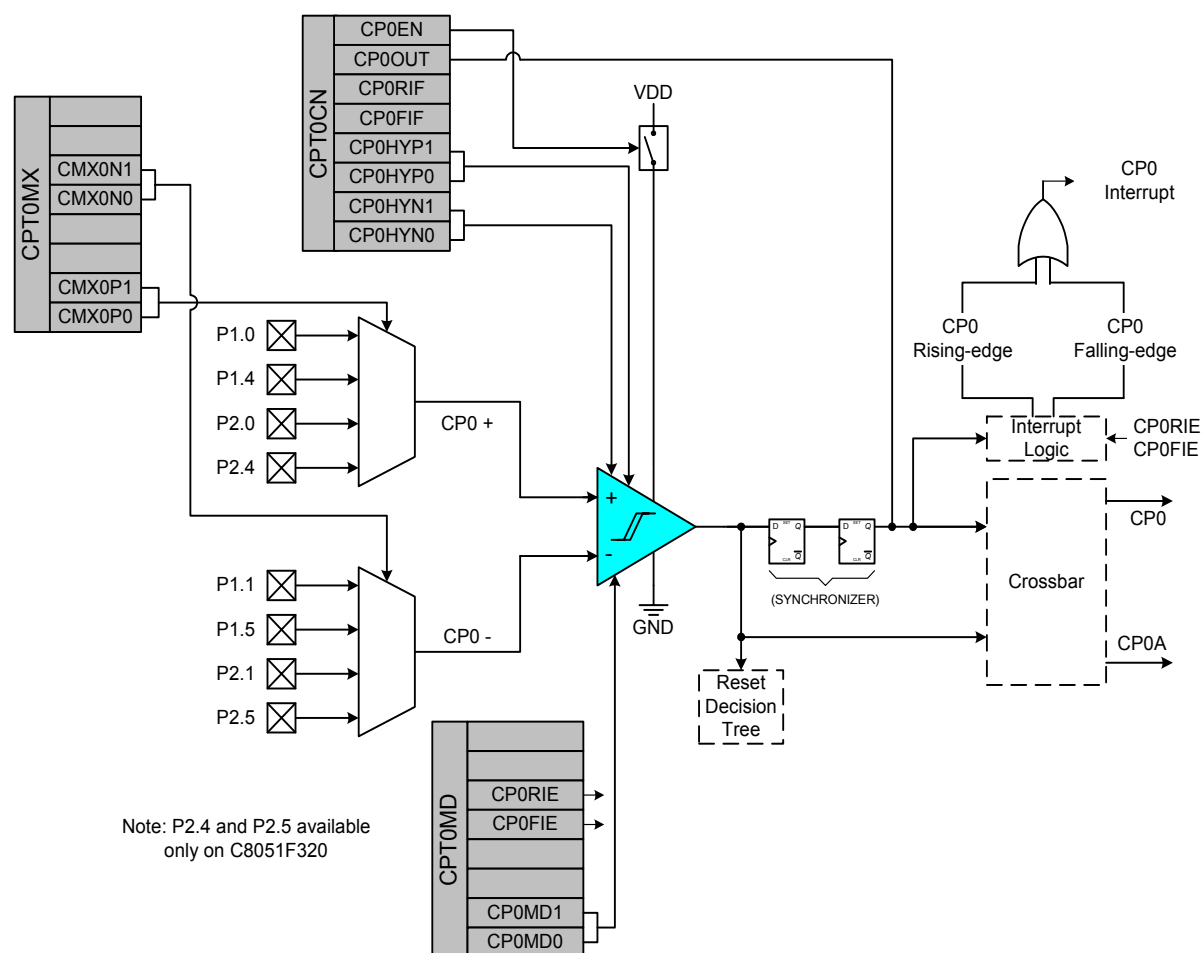
# C8051F320/1

## 1.10. Comparators

C8051F320/1 devices include two on-chip voltage comparators that are enabled/disabled and configured via user software. Port I/O pins may be configured as comparator inputs via a selection mux. Two comparator outputs may be routed to a Port pin if desired: a latched output and/or an unlatched (asynchronous) output. Comparator response time is programmable, allowing the user to select between high-speed and low-power modes. Positive and negative hysteresis are also configurable.

Comparator interrupts may be generated on rising, falling, or both edges. When in IDLE mode, these interrupts may be used as a “wake-up” source. Comparator0 may also be configured as a reset source. Figure 1.11 shows the Comparator0 block diagram.

**Figure 1.11. Comparator0 Block Diagram**



---

**2. ABSOLUTE MAXIMUM RATINGS****Table 2.1. Absolute Maximum Ratings\***

PARAMETER	CONDITIONS	MIN	TYP	MAX	UNITS
Ambient temperature under bias		-55		125	°C
Storage Temperature		-65		150	°C
Voltage on any Port I/O Pin or /RST with respect to GND		-0.3		5.8	V
Voltage on VDD with respect to GND		-0.3		4.2	V
Maximum Total current through VDD and GND				500	mA
Maximum output current sunk by /RST or any Port pin				100	mA

\*Note: stresses above those listed under “Absolute Maximum Ratings” may cause permanent damage to the device. This is a stress rating only and functional operation of the devices at those or any other conditions above those indicated in the operation listings of this specification is not implied. Exposure to maximum rating conditions for extended periods may affect device reliability.

# C8051F320/1

## 3. GLOBAL DC ELECTRICAL CHARACTERISTICS

**Table 3.1. Global DC Electrical Characteristics**

-40°C to +85°C, 25 MHz System Clock unless otherwise specified.

PARAMETER	CONDITIONS	MIN	TYP	MAX	UNITS
Digital Supply Voltage (Note 1)		2.7	3.3	3.6	V
Digital Supply Current with CPU active	VDD=3.3V, Clock=24MHz VDD=3.3V, Clock=1MHz VDD=3.3V, Clock=32kHz		10 0.6 30		mA mA μA
Digital Supply Current with CPU active and USB active (Full or Low Speed)	VDD=3.3V, Clock=24MHz VDD=3.3V, Clock=6MHz		TBD TBD		mA mA
Digital Supply Current with CPU inactive (not accessing FLASH)	VDD=3.3V, Clock=24MHz VDD=3.3V, Clock=1MHz VDD=3.3V, Clock=32kHz		5 0.3 14		mA mA μA
Digital Supply Current (suspend mode or shutdown mode)	Oscillator not running		< 0.1		μA
Digital Supply RAM Data Retention Voltage			1.5		V
SYSCLK (System Clock) (Note 2)		0		25	MHz
T <sub>SYSH</sub> (SYSCLK High Time)		18			ns
T <sub>SYSL</sub> (SYSCLK Low Time)		18			ns
Specified Operating Temperature Range		-40		+85	°C

Note 1: USB Requires 3.0 V Minimum Supply Voltage.

Note 2: SYSCLK must be at least 32 kHz to enable debugging.

#### 4. PINOUT AND PACKAGE DEFINITIONS

**Table 4.1. Pin Definitions for the C8051F320/1**

Name	Pin Numbers		Type	Description
	'F320	'F321		
VDD	6	6	Power In Power Out	2.7-3.6 V Power Supply Voltage Input. 3.3 V Voltage Regulator Output. See <a href="#">Section 8</a> .
GND	3	3		Ground.
/RST/ C2CK	9	9	D I/O D I/O	Device Reset. Open-drain output of internal POR or VDD monitor. An external source can initiate a system reset by driving this pin low for at least 15 $\mu$ s. See <a href="#">Section 10</a> . Clock signal for the C2 Debug Interface.
P3.0/ C2D	10	10	D I/O D I/O	Port 3.0. See <a href="#">Section 14</a> for a complete description. Bi-directional data signal for the C2 Debug Interface.
REGIN	7	7	Power In	5 V Regulator Input. This pin is the input to the on-chip voltage regulator.
VBUS	8	8	D In	VBUS Sense Input. This pin should be connected to the VBUS signal of a USB network. A 5 V signal on this pin indicates a USB network connection.
D+	4	4	D I/O	USB D+.
D-	5	5	D I/O	USB D-.
P0.0	2	2	D I/O	Port 0.0. See <a href="#">Section 14</a> for a complete description.
P0.1	1	1	D I/O	Port 0.1. See <a href="#">Section 14</a> for a complete description.
P0.2/ XTAL1	32	28	D I/O A In	Port 0.2. See <a href="#">Section 14</a> for a complete description. External Clock Input. This pin is the external oscillator return for a crystal or resonator. See <a href="#">Section 13</a> .
P0.3/ XTAL2	31	27	D I/O A I/O or D In	Port 0.3. See <a href="#">Section 14</a> for a complete description. External Clock Output. This pin is the excitation driver for an external crystal or resonator, or an external clock input for CMOS, capacitor, or RC oscillator configurations. See <a href="#">Section 13</a> .
P0.4	30	26	D I/O	Port 0.4. See <a href="#">Section 14</a> for a complete description.
P0.5	29	25	D I/O	Port 0.5. See <a href="#">Section 14</a> for a complete description.

# C8051F320/1

**Table 4.1. Pin Definitions for the C8051F320/1**

Name	Pin Numbers		Type	Description
	'F320	'F321		
P0.6/ CNVSTR	28	24		Port 0.6. See <b>Section 14</b> for a complete description. ADC0 External Convert Start Input. See <b>Section 5</b> .
P0.7/ VREF	27	23	D I/O A I/O	Port 0.7. See <b>Section 14</b> for a complete description. External VREF input or output. See <b>Section 6</b> .
P1.0	26	22	D I/O or A In	Port 1.0. See <b>Section 14</b> for a complete description.
P1.1	25	21	D I/O or A In	Port 1.1. See <b>Section 14</b> for a complete description.
P1.2	24	20	D I/O or A In	Port 1.2. See <b>Section 14</b> for a complete description.
P1.3	23	19	D I/O or A In	Port 1.3. See <b>Section 14</b> for a complete description.
P1.4	22	18	D I/O or A In	Port 1.4. See <b>Section 14</b> for a complete description.
P1.5	21	17	D I/O or A In	Port 1.5. See <b>Section 14</b> for a complete description.
P1.6	20	16	D I/O or A In	Port 1.6. See <b>Section 14</b> for a complete description.
P1.7	19	15	D I/O or A In	Port 1.7. See <b>Section 14</b> for a complete description.
P2.0	18	14	D I/O or A In	Port 2.0. See <b>Section 14</b> for a complete description.
P2.1	17	13	D I/O or A In	Port 2.1. See <b>Section 14</b> for a complete description.
P2.2	16	12	D I/O or A In	Port 2.2. See <b>Section 14</b> for a complete description.
P2.3	15	11	D I/O or A In	Port 2.3. See <b>Section 14</b> for a complete description.
P2.4	14		D I/O or A In	Port 2.4. See <b>Section 14</b> for a complete description.
P2.5	13		D I/O or A In	Port 2.5. See <b>Section 14</b> for a complete description.
P2.6	12		D I/O or A In	Port 2.6. See <b>Section 14</b> for a complete description.



**Table 4.1. Pin Definitions for the C8051F320/1**

Name	Pin Numbers		Type	Description
	'F320	'F321		
P2.7	11		D I/O or A In	Port 2.7. See <b>Section 14</b> for a complete description.

**Figure 4.1. LQFP-32 Pinout Diagram (Top View)**

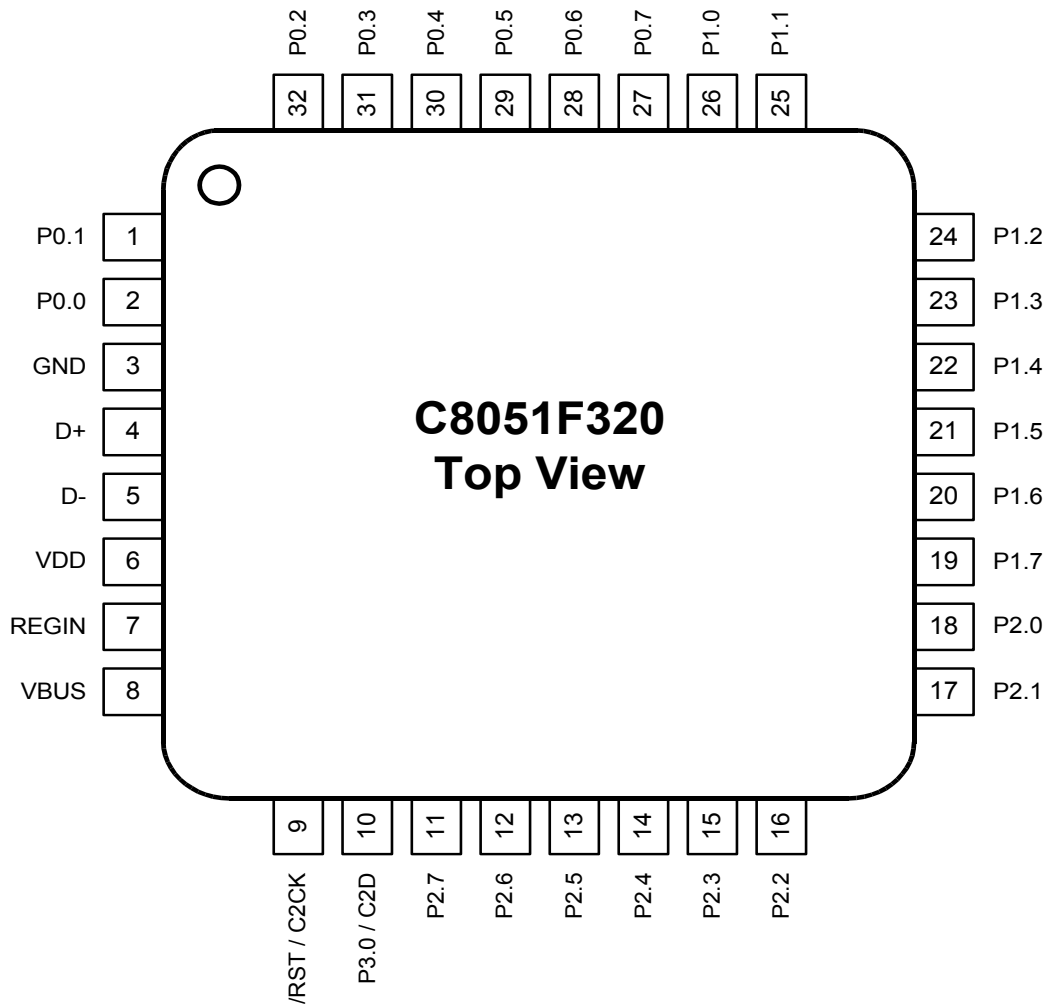


Figure 4.2. LQFP-32 Package Diagram

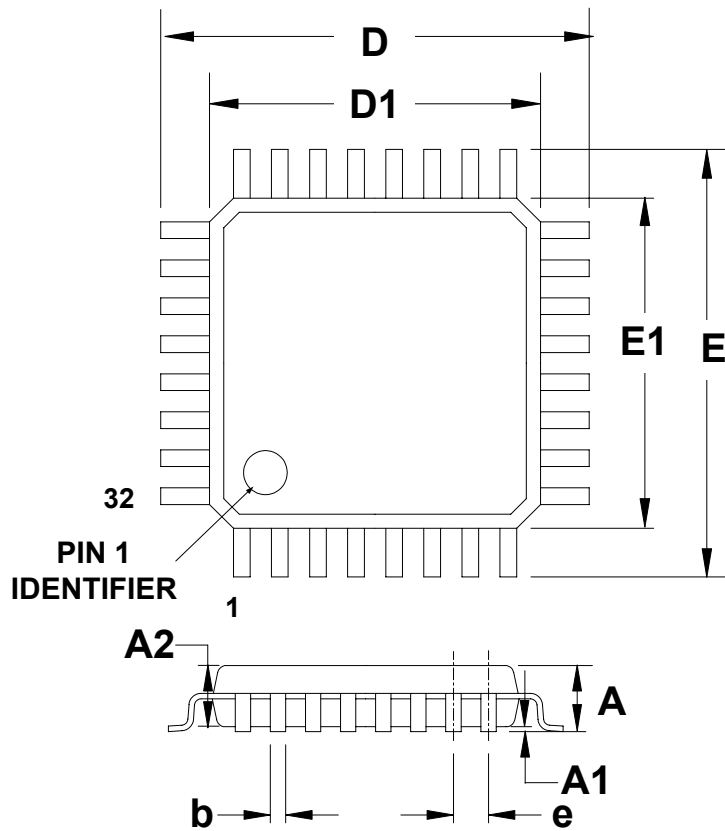


Table 4.2. LQFP-32 Package Dimensions

	MM		
	MIN	TYP	MAX
A	-	-	1.60
A1	0.05	-	0.15
A2	1.35	1.40	1.45
b	0.30	0.37	0.45
D	-	9.00	-
D1	-	7.00	-
e	-	0.80	-
E	-	9.00	-
E1	-	7.00	-

Figure 4.3. MLP-28 Pinout Diagram (Top View)

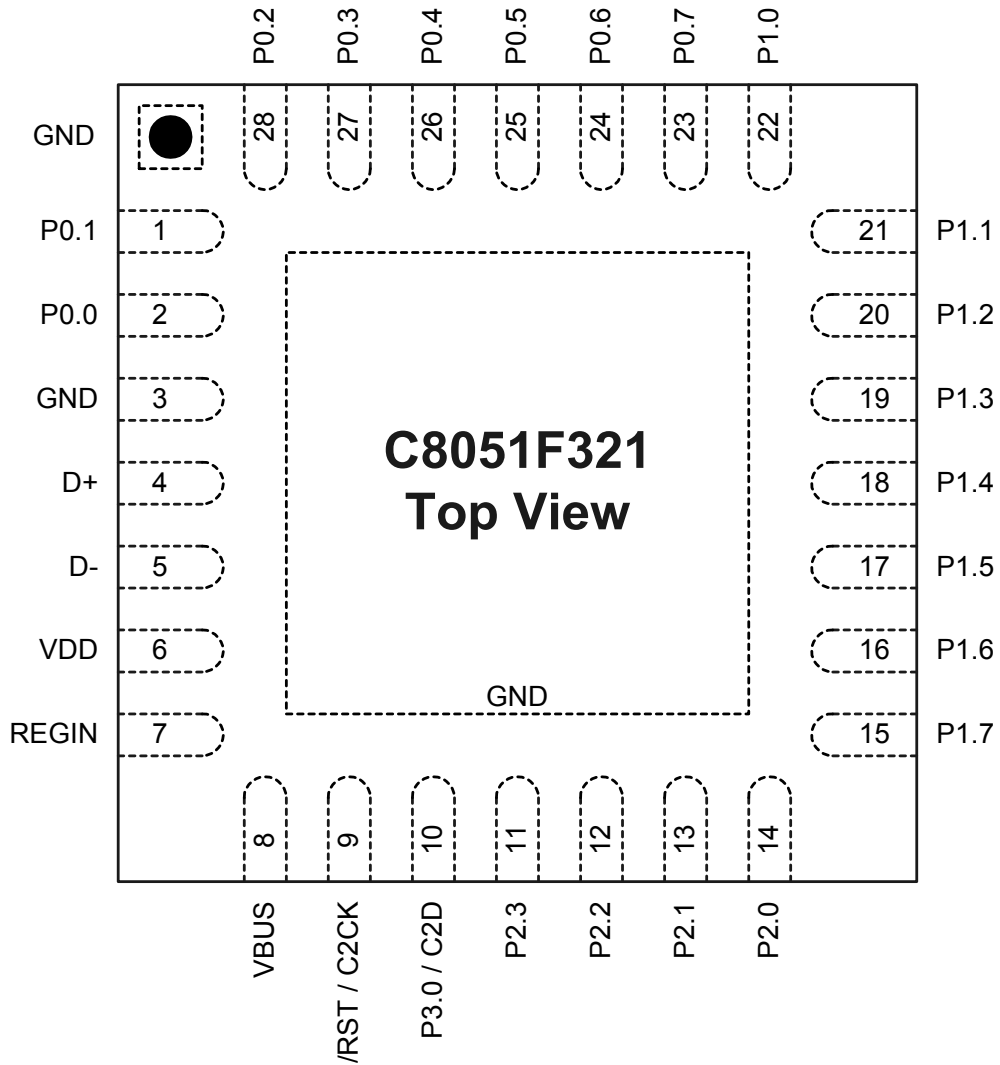


Figure 4.4. MLP-28 Package Drawing

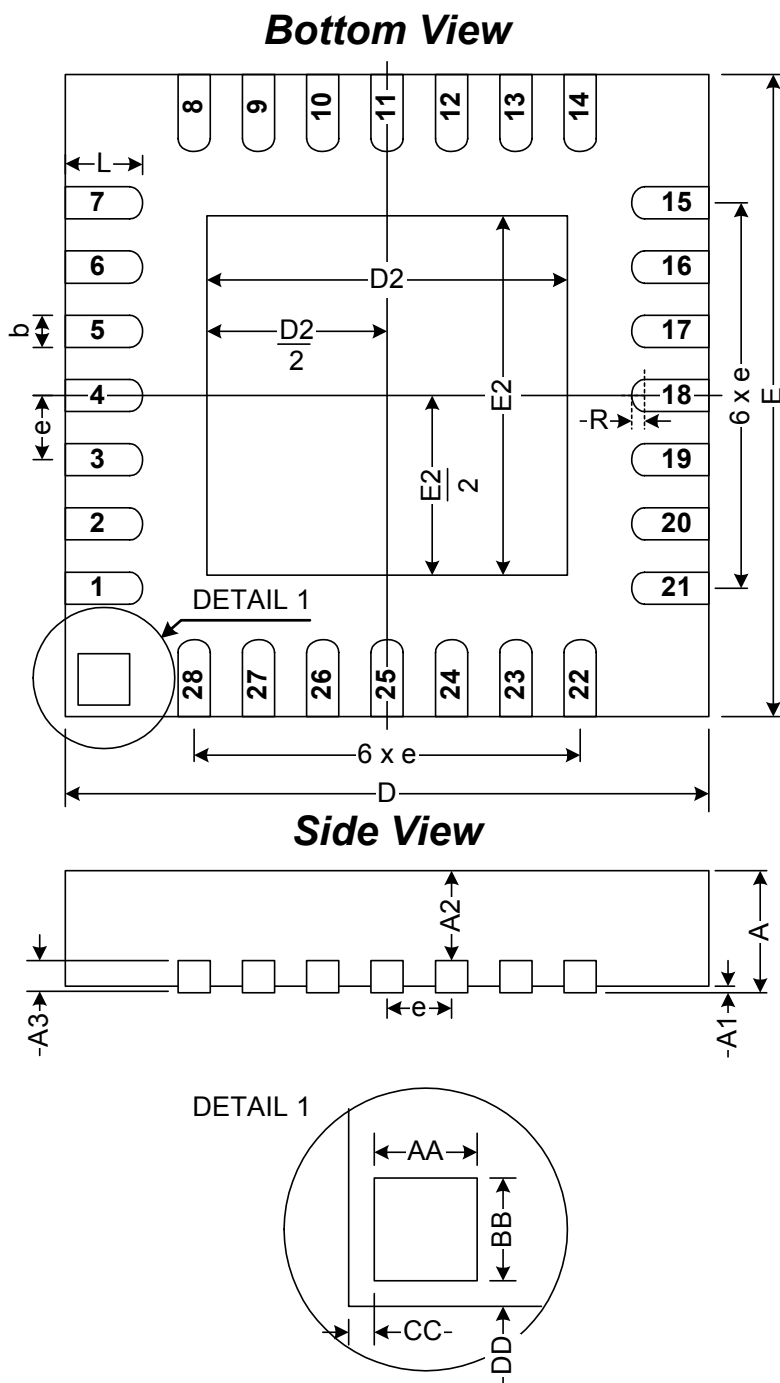


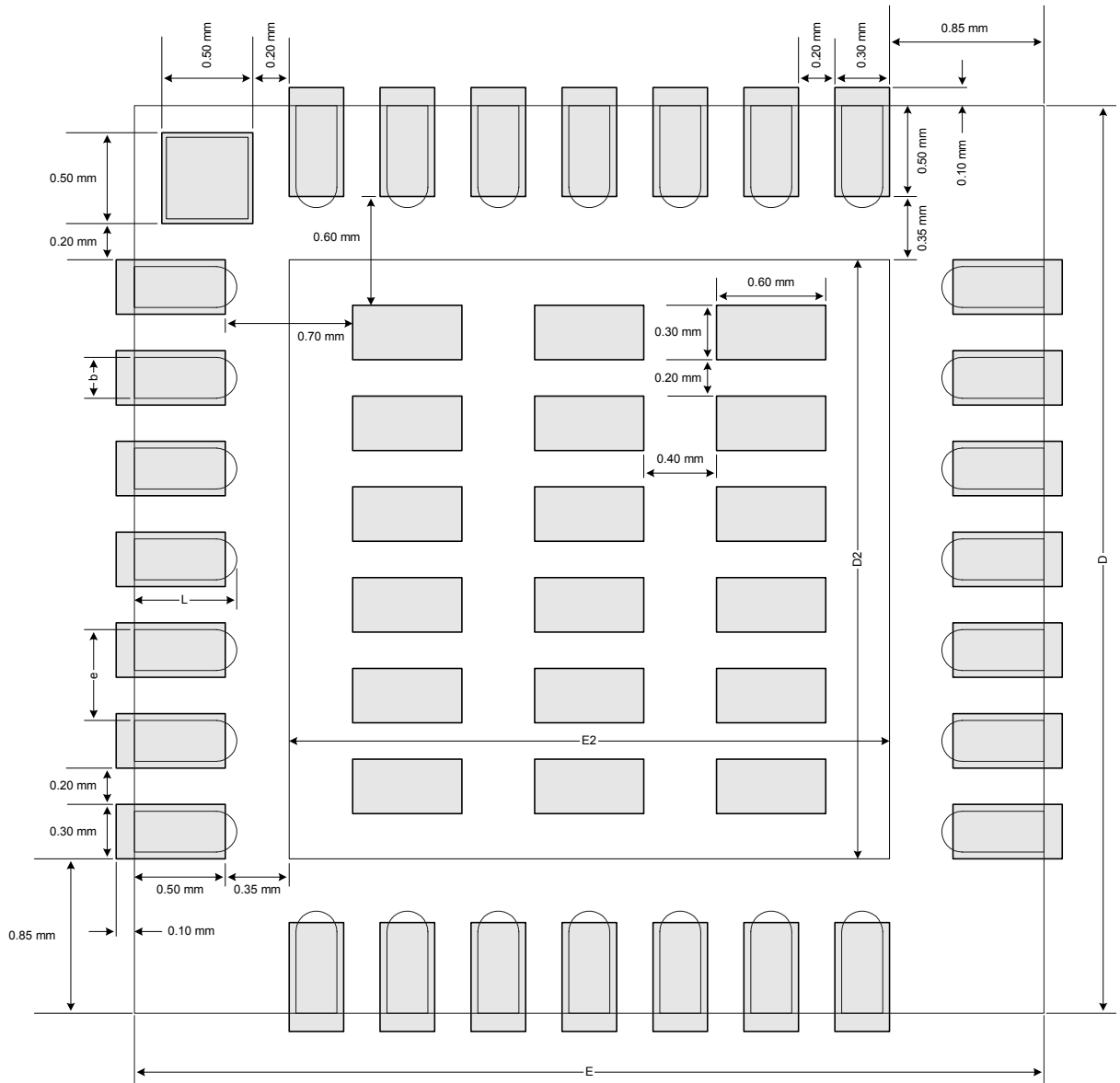
Table 4.2. MLP-28 Package Dimensions

	MM		
	MIN	TYP	MAX
A	0.80	0.90	1.00
A1	0	0.02	0.05
A2	0	0.65	1.00
A3	-	0.25	-
b	0.18	0.23	0.30
D	-	5.00	-
D2	2.90	3.15	3.35
E	-	5.00	-
E2	2.90	3.15	3.35
e	-	0.5	-
L	0.45	0.55	0.65
N	-	28	-
ND	-	7	-
NE	-	7	-
R	0.09	-	-
AA	-	0.435	-
BB	-	0.435	-
CC	-	0.18	-
DD	-	0.18	-



Figure 4.6. Typical MLP-28 Solder Mask

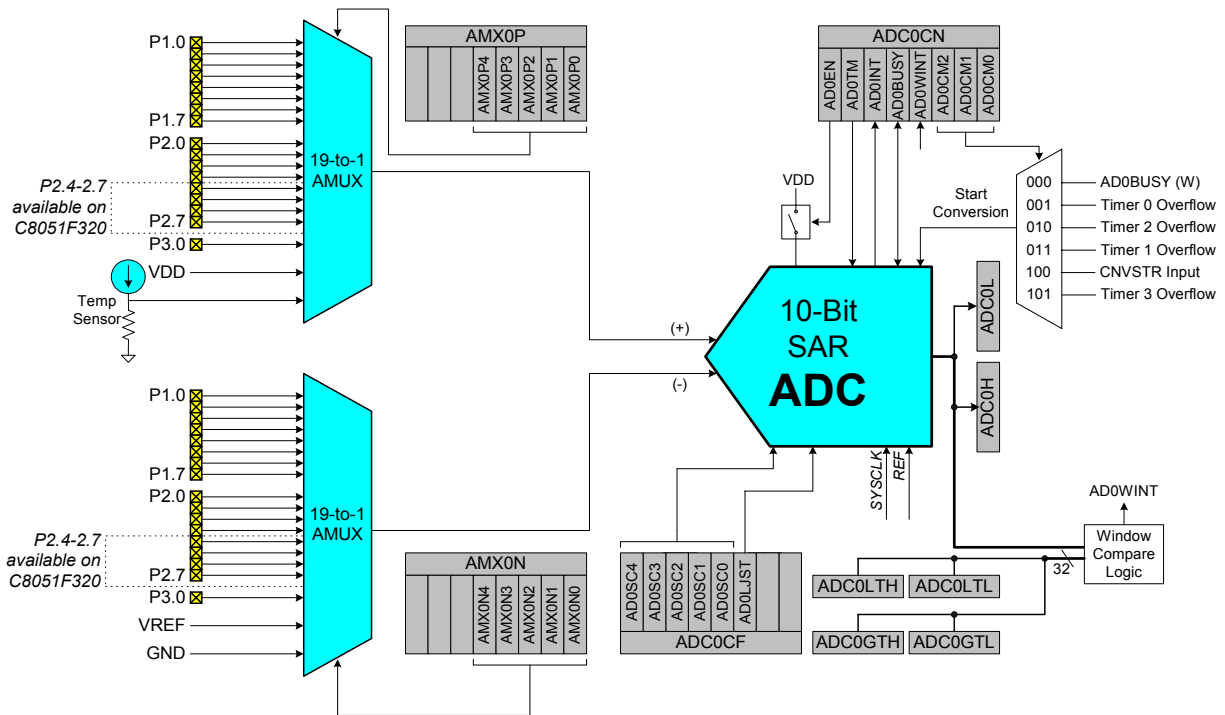
## Top View



## 5. 10-BIT ADC (ADC0)

The ADC0 subsystem for the C8051F320/1 consists of two analog multiplexers (referred to collectively as AMUX0) with 17 total input selections, and a 200 kps, 10-bit successive-approximation-register ADC with integrated track-and-hold and programmable window detector. The AMUX0, data conversion modes, and window detector are all configurable under software control via the Special Function Registers shown in Figure 5.1. ADC0 operates in both Single-ended and Differential modes, and may be configured to measure P1.0-P3.0, the Temperature Sensor output, or VDD with respect to P1.0-P3.0, VREF, or GND. The ADC0 subsystem is enabled only when the AD0EN bit in the ADC0 Control register (ADC0CN) is set to logic 1. The ADC0 subsystem is in low power shutdown when this bit is logic 0.

**Figure 5.1. ADC0 Functional Block Diagram**



## 5.1. Analog Multiplexer

AMUX0 selects the positive and negative inputs to the ADC. Any of the following may be selected as the positive input: P1.0-P3.0, the on-chip temperature sensor, or the positive power supply (VDD). Any of the following may be selected as the negative input: P1.0-P3.0, VREF, or GND. **When GND is selected as the negative input, ADC0 operates in Single-ended Mode; all other times, ADC0 operates in Differential Mode.** The ADC0 input channels are selected in the AMX0P and AMX0N registers as described in Figure 5.5 and Figure 5.6.

The conversion code format differs between Single-ended and Differential modes. The registers ADC0H and ADC0L contain the high and low bytes of the output conversion code from the ADC at the completion of each conversion. Data can be right-justified or left-justified, depending on the setting of the AD0LJST bit (ADC0CN.0). When in Single-ended Mode, conversion codes are represented as 10-bit unsigned integers. Inputs are measured from '0' to  $VREF * 1023/1024$ . Example codes are shown below for both right-justified and left-justified data. Unused bits in the ADC0H and ADC0L registers are set to '0'.

Input Voltage (Single-Ended)	Right-Justified ADC0H:ADC0L (AD0LJST = 0)	Left-Justified ADC0H:ADC0L (AD0LJST = 1)
$VREF * 1023/1024$	0x03FF	0xFFC0
$VREF * 512/1024$	0x0200	0x8000
$VREF * 256/1024$	0x0100	0x4000
0	0x0000	0x0000

When in Differential Mode, conversion codes are represented as 10-bit signed 2's complement numbers. Inputs are measured from  $-VREF$  to  $VREF * 511/512$ . Example codes are shown below for both right-justified and left-justified data. For right-justified data, the unused MSBs of ADC0H are a sign-extension of the data word. For left-justified data, the unused LSBs in the ADC0L register are set to '0'.

Input Voltage (Differential)	Right-Justified ADC0H:ADC0L (AD0LJST = 0)	Left-Justified ADC0H:ADC0L (AD0LJST = 1)
$VREF * 511/512$	0x01FF	0x7FC0
$VREF * 256/512$	0x0100	0x4000
0	0x0000	0x0000
$-VREF * 256/512$	0xFF00	0xC000
$-VREF$	0xFE00	0x8000

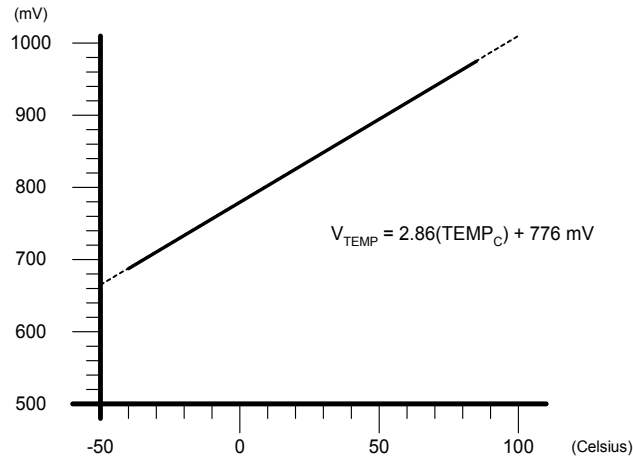
**Important Note About ADC0 Input Configuration:** Port pins selected as ADC0 inputs should be configured as analog inputs, and should be skipped by the Digital Crossbar. To configure a Port pin for analog input, set to '0' the corresponding bit in register PnMDIN (for n = 0,1,2,3). To force the Crossbar to skip a Port pin, set to '1' the corresponding bit in register PnSKIP (for n = 0,1,2). See **Section "14. Port Input/Output" on page 127** for more Port I/O configuration details.



## 5.2. Temperature Sensor

The typical temperature sensor transfer function is shown in Figure 5.2. The output voltage ( $V_{TEMP}$ ) is the positive ADC input when the temperature sensor is selected by bits AMX0P4-0 in register AMX0P.

**Figure 5.2. Typical Temperature Sensor Transfer Function**



**Note that parameters which affect ADC measurement, in particular the voltage reference value, will also affect temperature measurement.**

## 5.3. Modes of Operation

ADC0 has a maximum conversion speed of 200 ksps. The ADC0 conversion clock is a divided version of the system clock, determined by the AD0SC bits in the ADC0CF register (system clock divided by  $(AD0SC + 1)$  for  $0 \leq AD0SC \leq 31$ ).

### 5.3.1. Starting a Conversion

A conversion can be initiated in one of five ways, depending on the programmed states of the ADC0 Start of Conversion Mode bits (AD0CM2-0) in register ADC0CN. Conversions may be initiated by one of the following:

1. Writing a '1' to the AD0BUSY bit of register ADC0CN
2. A Timer 0 overflow (i.e., timed continuous conversions)
3. A Timer 2 overflow
4. A Timer 1 overflow
5. A rising edge on the CNVSTR input signal (pin P0.6)
6. A Timer 3 overflow

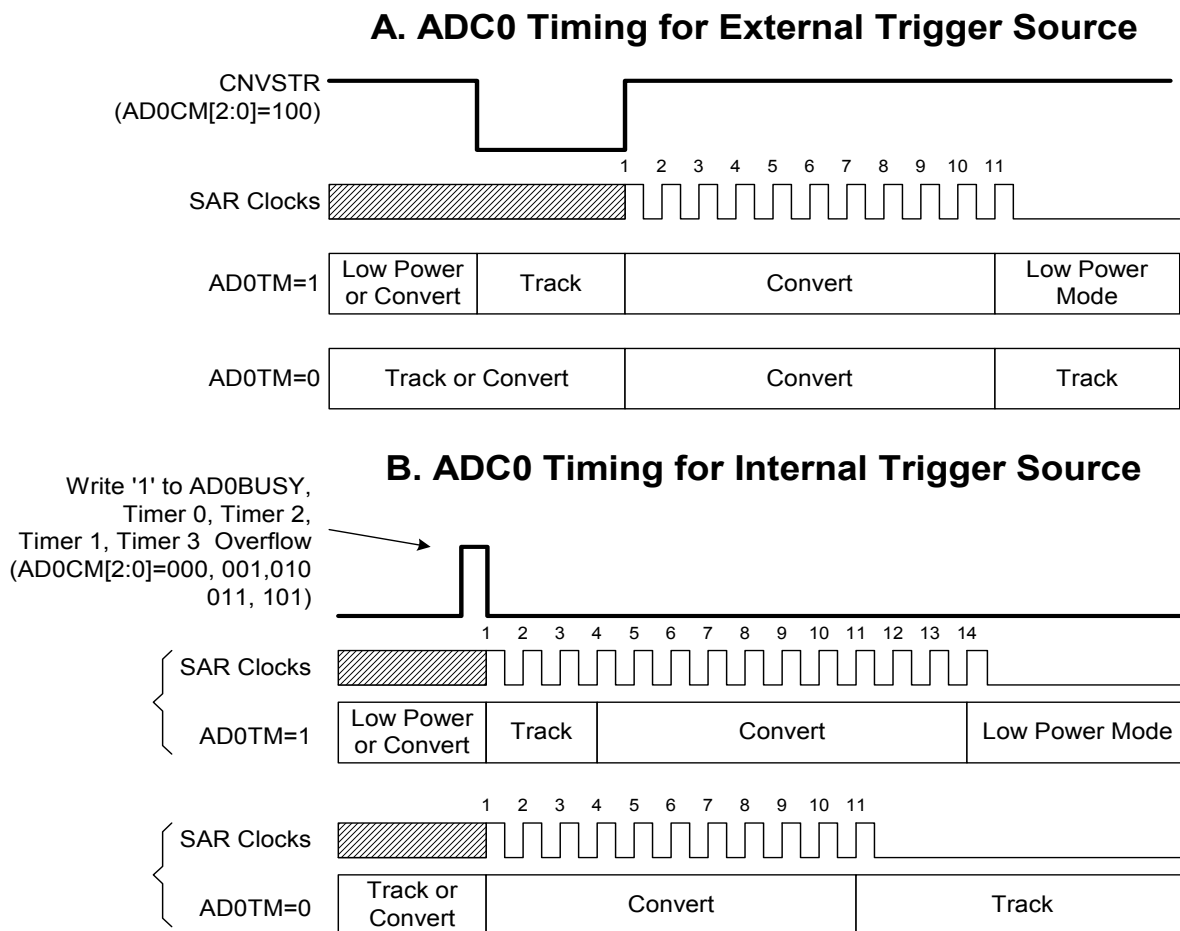
Writing a '1' to AD0BUSY provides software control of ADC0 whereby conversions are performed "on-demand". During conversion, the AD0BUSY bit is set to logic 1 and reset to logic 0 when the conversion is complete. The falling edge of AD0BUSY triggers an interrupt (when enabled) and sets the ADC0 interrupt flag (AD0INT). Note: When polling for ADC conversion completions, the ADC0 interrupt flag (AD0INT) should be used. Converted data is available in the ADC0 data registers, ADC0H:ADC0L, when bit AD0INT is logic 1. Note that when Timer 2 or Timer 3 overflows are used as the conversion source, Low Byte overflows are used if Timer 2/3 is in 8-bit mode; High byte overflows are used if Timer 2/3 is in 16-bit mode. See [Section "19. Timers" on page 217](#) for timer configuration.

**Important Note About Using CNVSTR:** The CNVSTR input pin also functions as Port pin P0.6. When the CNVSTR input is used as the ADC0 conversion source, Port pin P0.6 should be skipped by the Digital Crossbar. To configure the Crossbar to skip P0.6, set to '1' Bit6 in register P0SKIP. See [Section "14. Port Input/Output" on page 127](#) for details on Port I/O configuration.

## 5.3.2. Tracking Modes

The AD0TM bit in register ADC0CN controls the ADC0 track-and-hold mode. In its default state, the ADC0 input is continuously tracked, except when a conversion is in progress. When the AD0TM bit is logic 1, ADC0 operates in low-power track-and-hold mode. In this mode, each conversion is preceded by a tracking period of 3 SAR clocks (after the start-of-conversion signal). When the CNVSTR signal is used to initiate conversions in low-power tracking mode, ADC0 tracks only when CNVSTR is low; conversion begins on the rising edge of CNVSTR (see Figure 5.3). Tracking can also be disabled (shutdown) when the device is in low power standby or sleep modes. Low-power track-and-hold mode is also useful when AMUX settings are frequently changed, due to the settling time requirements described in **Section “5.3.3. Settling Time Requirements” on page 44.**

**Figure 5.3. 10-Bit ADC Track and Conversion Example Timing**



## 5.3.3. Settling Time Requirements

When the ADC0 input configuration is changed (i.e., a different AMUX0 selection is made), a minimum tracking time is required before an accurate conversion can be performed. This tracking time is determined by the AMUX0 resistance, the ADC0 sampling capacitance, any external source resistance, and the accuracy required for the conversion. Note that in low-power tracking mode, three SAR clocks are used for tracking at the start of every conversion. For most applications, these three SAR clocks will meet the minimum tracking time requirements.

Figure 5.4 shows the equivalent ADC0 input circuits for both Differential and Single-ended modes. Notice that the equivalent time constant for both input circuits is the same. The required ADC0 settling time for a given settling accuracy (SA) may be approximated by Equation 5.1. When measuring the Temperature Sensor output or VDD with respect to GND,  $R_{TOTAL}$  reduces to  $R_{MUX}$ . See Table 5.1 for ADC0 minimum settling time requirements.

### Equation 5.1. ADC0 Settling Time Requirements

$$t = \ln\left(\frac{2^n}{SA}\right) \times R_{TOTAL} C_{SAMPLE}$$

Where:

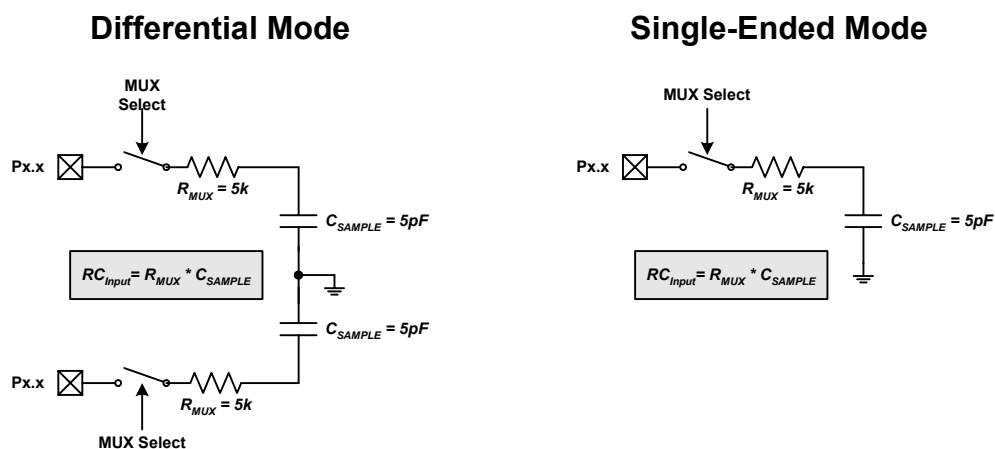
$SA$  is the settling accuracy, given as a fraction of an LSB (for example, 0.25 to settle within 1/4 LSB)

$t$  is the required settling time in seconds

$R_{TOTAL}$  is the sum of the AMUX0 resistance and any external source resistance.

$n$  is the ADC resolution in bits (10).

Figure 5.4. ADC0 Equivalent Input Circuits



**Figure 5.5. AMX0P: AMUX0 Positive Channel Select Register**

R	R	R	R/W	R/W	R/W	R/W	R/W	Reset Value
-	-	-	AMX0P4	AMX0P3	AMX0P2	AMX0P1	AMX0P0	00000000
Bit7	Bit6	Bit5	Bit4	Bit3	Bit2	Bit1	Bit0	SFR Address: 0xBB

Bits7-5: UNUSED. Read = 000b; Write = don't care.  
 Bits4-0: AMX0P4-0: AMUX0 Positive Input Selection

AMX0P4-0	ADC0 Positive Input
00000	P1.0
00001	P1.1
00010	P1.2
00011	P1.3
00100	P1.4
00101	P1.5
00110	P1.6
00111	P1.7
01000	P2.0
01001	P2.1
01010	P2.2
01011	P2.3
01100†	P2.4†
01101†	P2.5†
01110†	P2.6†
01111†	P2.7†
10000	P3.0
10001 - 11101	RESERVED
11110	Temp Sensor
11111	VDD

†Only applies to C8051F320; selection RESERVED on C8051F321 devices.

**Figure 5.6. AMX0N: AMUX0 Negative Channel Select Register**

R	R	R	R/W	R/W	R/W	R/W	R/W	Reset Value
-	-	-	AMX0N4	AMX0N3	AMX0N2	AMX0N1	AMX0N0	00000000
Bit7	Bit6	Bit5	Bit4	Bit3	Bit2	Bit1	Bit0	SFR Address: 0xBA

Bits7-5: UNUSED. Read = 000b; Write = don't care.

Bits4-0: AMX0N4-0: AMUX0 Negative Input Selection.

Note that when GND is selected as the Negative Input, ADC0 operates in Single-ended mode. For all other Negative Input selections, ADC0 operates in Differential mode.

AMX0N4-0	ADC0 Negative Input
00000	P1.0
00001	P1.1
00010	P1.2
00011	P1.3
00100	P1.4
00101	P1.5
00110	P1.6
00111	P1.7
01000	P2.0
01001	P2.1
01010	P2.2
01011	P2.3
01100†	P2.4†
01101†	P2.5†
01110†	P2.6†
01111†	P2.7†
10000	P3.0
10001 - 11101	RESERVED
11110	VREF
11111	GND (ADC in Single-Ended Mode)

†Only applies to C8051F320; selection RESERVED on C8051F321 devices.

**Figure 5.7. ADC0CF: ADC0 Configuration Register**

R/W	R/W	R/W	R/W	R/W	R/W	R/W	R/W	Reset Value
AD0SC4	AD0SC3	AD0SC2	AD0SC1	AD0SC0	AD0LJST	-	-	11111000
Bit7	Bit6	Bit5	Bit4	Bit3	Bit2	Bit1	Bit0	SFR Address: 0xBC

Bits7-3: AD0SC4-0: ADC0 SAR Conversion Clock Period Bits.  
SAR Conversion clock is derived from system clock by the following equation, where *AD0SC* refers to the 5-bit value held in bits AD0SC4-0. SAR Conversion clock requirements are given in Table 5.1.

$$AD0SC = \frac{SYSCLK}{CLK_{SAR}} - 1$$

Bit2: AD0LJST: ADC0 Left Justify Select.  
0: Data in ADC0H:ADC0L registers are right-justified.  
1: Data in ADC0H:ADC0L registers are left-justified.

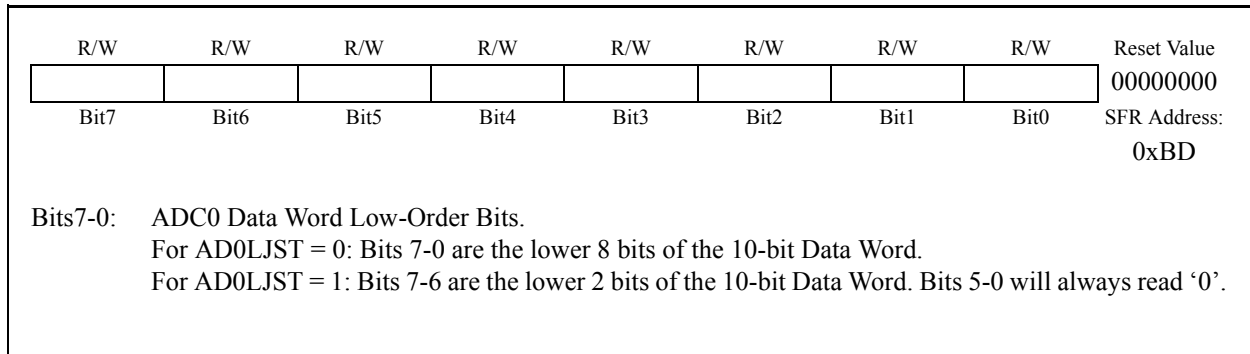
Bits1-0: UNUSED. Read = 00b; Write = don't care.

**Figure 5.8. ADC0H: ADC0 Data Word MSB Register**

R/W	R/W	R/W	R/W	R/W	R/W	R/W	R/W	Reset Value
								00000000
Bit7	Bit6	Bit5	Bit4	Bit3	Bit2	Bit1	Bit0	SFR Address: 0xBE

Bits7-0: ADC0 Data Word High-Order Bits.  
For AD0LJST = 0: Bits 7-2 are the sign extension of Bit1. Bits 1-0 are the upper 2 bits of the 10-bit ADC0 Data Word.  
For AD0LJST = 1: Bits 7-0 are the most-significant bits of the 10-bit ADC0 Data Word.

**Figure 5.9. ADC0L: ADC0 Data Word LSB Register**





**Figure 5.10. ADC0CN: ADC0 Control Register**

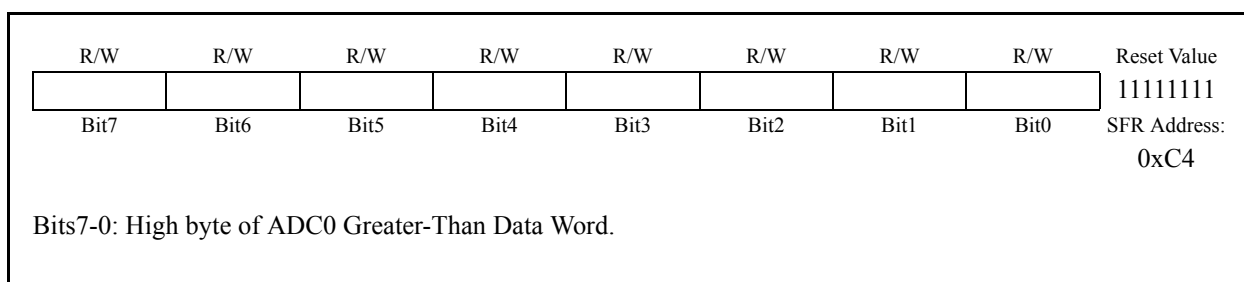
R/W	R/W	R/W	R/W	R/W	R/W	R/W	R/W	Reset Value
AD0EN	AD0TM	AD0INT	AD0BUSY	AD0WINT	AD0CM2	AD0CM1	AD0CM0	00000000
Bit7	Bit6	Bit5	Bit4	Bit3	Bit2	Bit1	Bit0	SFR Address: (bit addressable) 0xE8
<p>Bit7: AD0EN: ADC0 Enable Bit. 0: ADC0 Disabled. ADC0 is in low-power shutdown. 1: ADC0 Enabled. ADC0 is active and ready for data conversions.</p> <p>Bit6: AD0TM: ADC0 Track Mode Bit. 0: Normal Track Mode: When ADC0 is enabled, tracking is continuous unless a conversion is in progress. 1: Low-power Track Mode: Tracking Defined by AD0CM2-0 bits (see below).</p> <p>Bit5: AD0INT: ADC0 Conversion Complete Interrupt Flag. 0: ADC0 has not completed a data conversion since the last time AD0INT was cleared. 1: ADC0 has completed a data conversion.</p> <p>Bit4: AD0BUSY: ADC0 Busy Bit. Read: 0: ADC0 conversion is complete or a conversion is not currently in progress. AD0INT is set to logic 1 on the falling edge of AD0BUSY. 1: ADC0 conversion is in progress. Write: 0: No Effect. 1: Initiates ADC0 Conversion if AD0CM2-0 = 000b</p> <p>Bit3: AD0WINT: ADC0 Window Compare Interrupt Flag. 0: ADC0 Window Comparison Data match has not occurred since this flag was last cleared. 1: ADC0 Window Comparison Data match has occurred.</p> <p>Bits2-0: AD0CM2-0: ADC0 Start of Conversion Mode Select. When AD0TM = 0: 000: ADC0 conversion initiated on every write of '1' to AD0BUSY. 001: ADC0 conversion initiated on overflow of Timer 0. 010: ADC0 conversion initiated on overflow of Timer 2. 011: ADC0 conversion initiated on overflow of Timer 1. 100: ADC0 conversion initiated on rising edge of external CNVSTR. 101: ADC0 conversion initiated on overflow of Timer 3. 11x: Reserved. When AD0TM = 1: 000: Tracking initiated on write of '1' to AD0BUSY and lasts 3 SAR clocks, followed by conversion. 001: Tracking initiated on overflow of Timer 0 and lasts 3 SAR clocks, followed by conversion. 010: Tracking initiated on overflow of Timer 2 and lasts 3 SAR clocks, followed by conversion. 011: Tracking initiated on overflow of Timer 1 and lasts 3 SAR clocks, followed by conversion. 100: ADC0 tracks only when CNVSTR input is logic low; conversion starts on rising CNVSTR edge. 101: Tracking initiated on overflow of Timer 3 and lasts 3 SAR clocks, followed by conversion. 11x: Reserved.</p>								

## 5.4. Programmable Window Detector

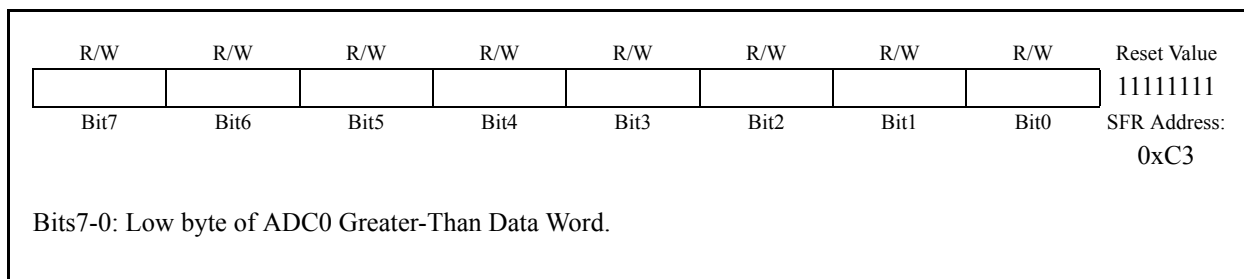
The ADC Programmable Window Detector continuously compares the ADC0 conversion results to user-programmed limits, and notifies the system when a desired condition is detected. This is especially effective in an interrupt-driven system, saving code space and CPU bandwidth while delivering faster system response times. The window detector interrupt flag (AD0WINT in register ADC0CN) can also be used in polled mode. The ADC0 Greater-Than (ADC0GTH, ADC0GTL) and Less-Than (ADC0LTH, ADC0LTL) registers hold the comparison values. The window detector flag can be programmed to indicate when measured data is inside or outside of the user-programmed limits, depending on the contents of the ADC0 Less-Than and ADC0 Greater-Than registers.

The Window Detector registers must be written with the same format (left/right justified, signed/unsigned) as that of the current ADC configuration (left/right justified, single-ended/differential).

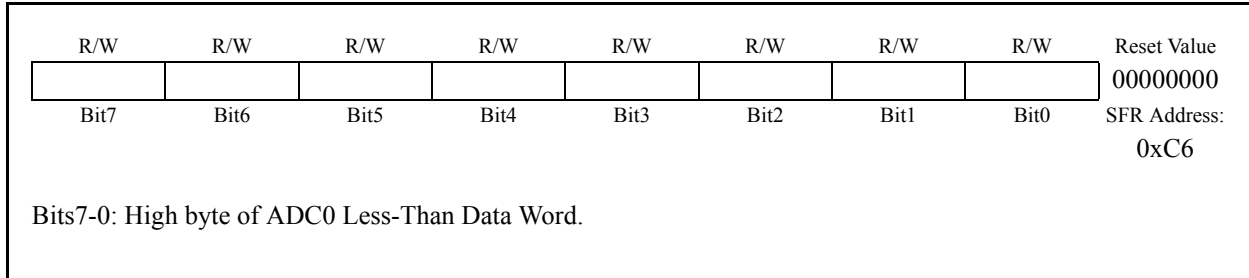
**Figure 5.11. ADC0GTH: ADC0 Greater-Than Data High Byte Register**



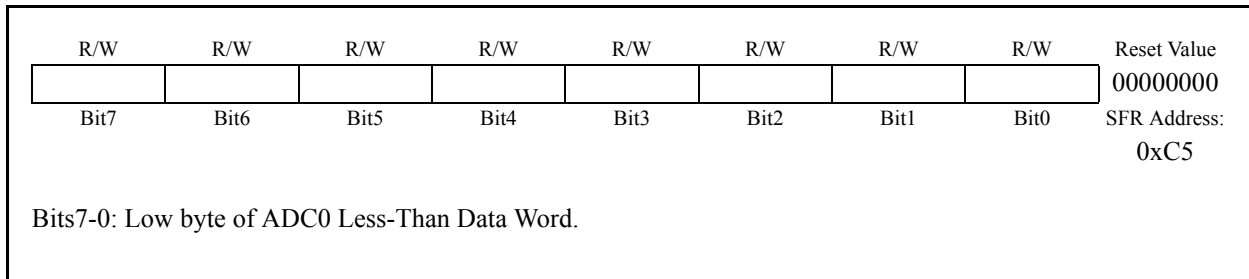
**Figure 5.12. ADC0GTL: ADC0 Greater-Than Data Low Byte Register**



**Figure 5.13. ADC0LTH: ADC0 Less-Than Data High Byte Register**



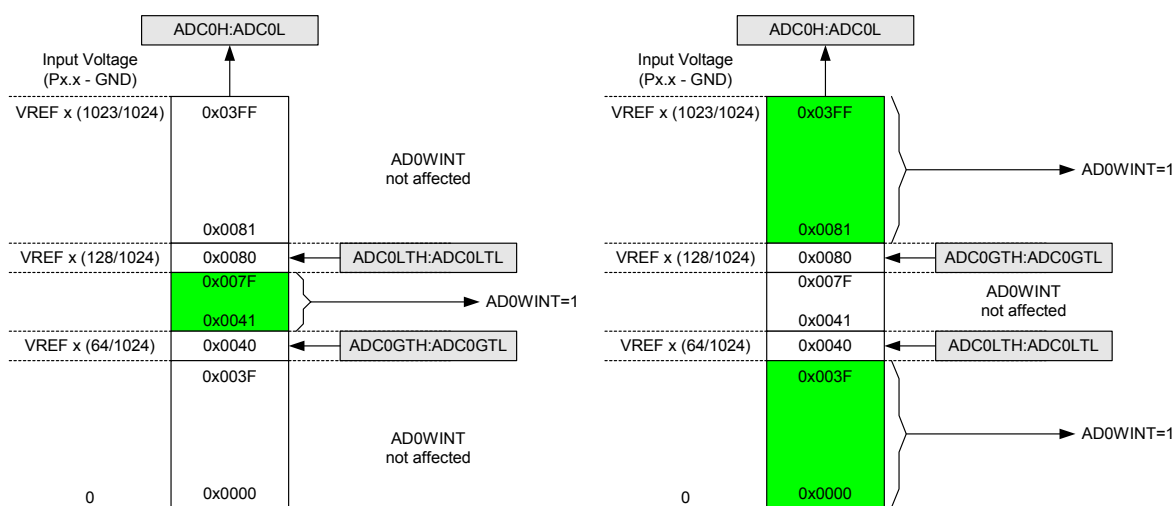
**Figure 5.14. ADC0LTL: ADC0 Less-Than Data Low Byte Register**



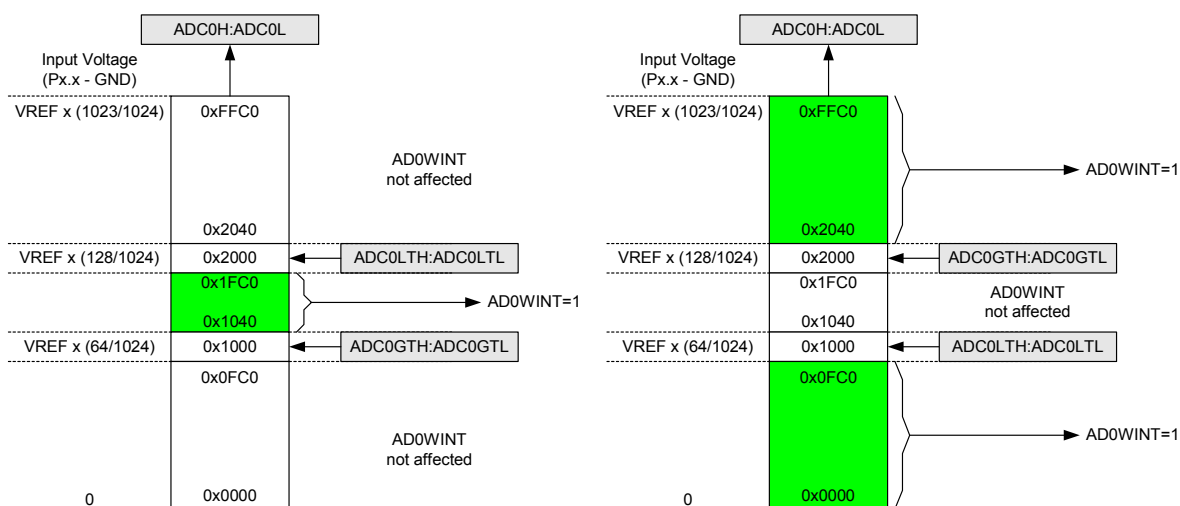
## 5.4.1. Window Detector In Single-Ended Mode

Figure 5.15 shows two example window comparisons for right-justified, single-ended data, with ADC0LTH:ADC0LTL = 0x0080 (128d) and ADC0GTH:ADC0GTL = 0x0040 (64d). In single-ended mode, the input voltage can range from '0' to VREF \* (1023/1024) with respect to GND, and is represented by a 10-bit unsigned integer value. In the left example, an AD0WINT interrupt will be generated if the ADC0 conversion word (ADC0H:ADC0L) is within the range defined by ADC0GTH:ADC0GTL and ADC0LTH:ADC0LTL (if  $0x0040 < \text{ADC0H:ADC0L} < 0x0080$ ). In the right example, an AD0WINT interrupt will be generated if the ADC0 conversion word is outside of the range defined by the ADC0GT and ADC0LT registers (if  $\text{ADC0H:ADC0L} < 0x0040$  or  $\text{ADC0H:ADC0L} > 0x0080$ ). Figure 5.16 shows an example using left-justified data with equivalent ADC0GT and ADC0LT register settings.

**Figure 5.15. ADC Window Compare Example: Right-Justified Single-Ended Data**



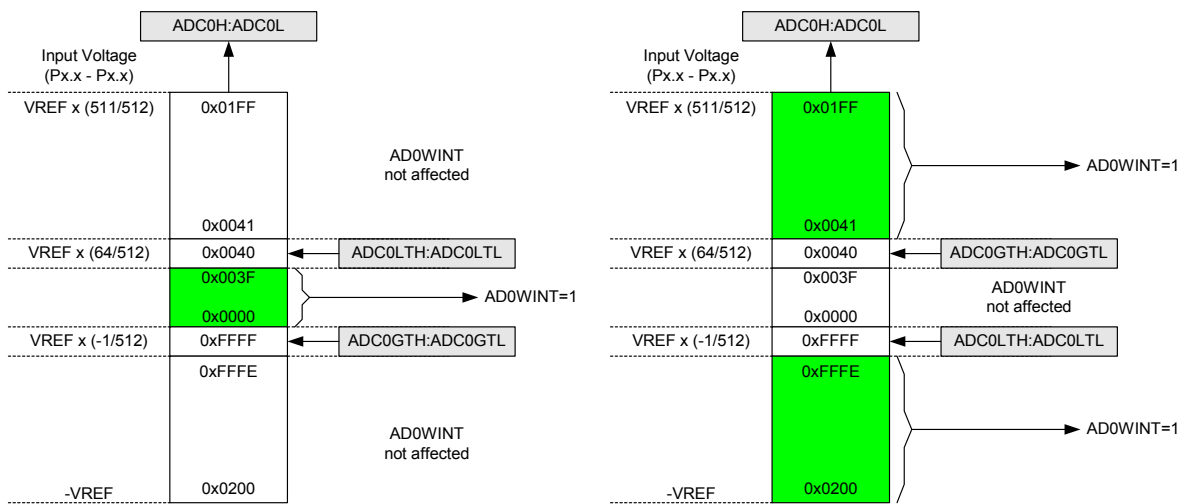
**Figure 5.16. ADC Window Compare Example: Left-Justified Single-Ended Data**



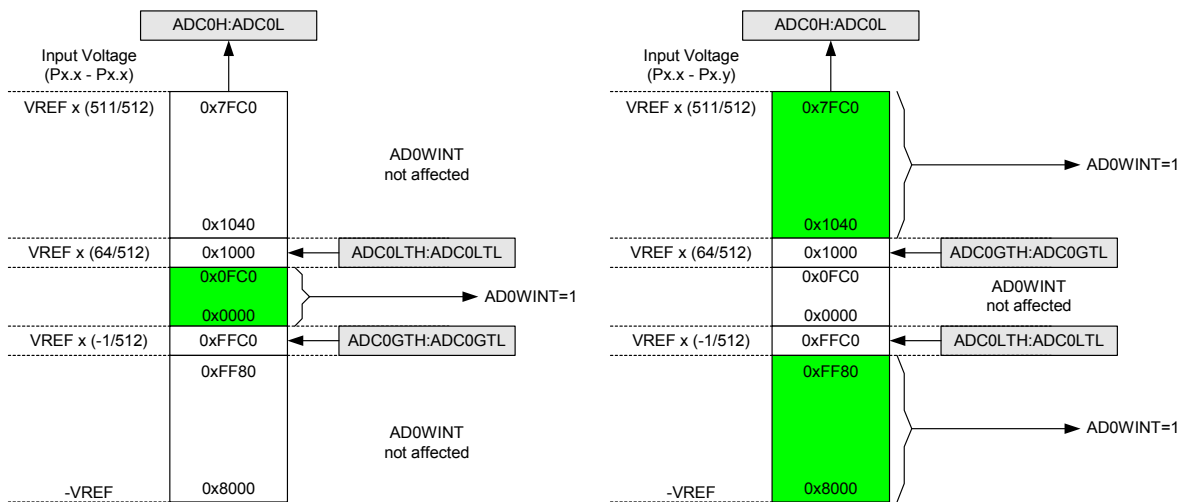
## 5.4.2. Window Detector In Differential Mode

Figure 5.17 shows two example window comparisons for right-justified, differential data, with ADC0LTH:ADC0LTL = 0x0040 (+64d) and ADC0GTH:ADC0GTL = 0xFFFF (-1d). In differential mode, the measurable voltage between the input pins is between -VREF and VREF\*(511/512). Output codes are represented as 10-bit 2's complement signed integers. In the left example, an AD0WINT interrupt will be generated if the ADC0 conversion word (ADC0H:ADC0L) is within the range defined by ADC0GTH:ADC0GTL and ADC0LTH:ADC0LTL (if 0xFFFF (-1d) < ADC0H:ADC0L < 0x0040 (64d)). In the right example, an AD0WINT interrupt will be generated if the ADC0 conversion word is outside of the range defined by the ADC0GT and ADC0LT registers (if ADC0H:ADC0L < 0xFFFF (-1d) or ADC0H:ADC0L > 0x0040 (+64d)). Figure 5.18 shows an example using left-justified data with equivalent ADC0GT and ADC0LT register settings.

**Figure 5.17. ADC Window Compare Example: Right-Justified Differential Data**



**Figure 5.18. ADC Window Compare Example: Left-Justified Differential Data**



# C8051F320/1

**Table 5.1. ADC0 Electrical Characteristics**

VDD = 3.0 V, VREF = 2.40 V, -40°C to +85°C unless otherwise specified

PARAMETER	CONDITIONS	MIN	TYP	MAX	UNITS
<b>DC ACCURACY</b>					
Resolution			10		bits
Integral Nonlinearity			±0.5	±1	LSB
Differential Nonlinearity	Guaranteed Monotonic		±0.5	±1	LSB
Offset Error			0		LSB
Full Scale Error			-1		LSB
Offset Temperature Coefficient			10		ppm/°C
<b>DYNAMIC PERFORMANCE (10 kHz sine-wave Single-ended input, 1 dB below Full Scale, 200 ksps)</b>					
Signal-to-Noise Plus Distortion		53	55.5		dB
Total Harmonic Distortion	Up to the 5 <sup>th</sup> harmonic		-67		dB
Spurious-Free Dynamic Range			78		dB
<b>CONVERSION RATE</b>					
SAR Conversion Clock				3	MHz
Conversion Time in SAR Clocks		10			clocks
Track/Hold Acquisition Time		300			ns
Throughput Rate				200	ksps
<b>ANALOG INPUTS</b>					
ADC Input Voltage Range	Single Ended (AIN+ - GND) Differential (AIN+ - AIN-)	0 -VREF		VREF VREF	V V
Absolute Pin Voltage with respect to GND	Single Ended or Differential	0		VDD	V
Input Capacitance			5		pF
<b>TEMPERATURE SENSOR</b>					
Linearity	Note 1		±0.1		°C
Gain	Note 2		2.86		mV / °C
Offset	Notes 1, 2 (Temp = 0 °C)		0.776 ±8.5		mV
<b>POWER SPECIFICATIONS</b>					
Power Supply Current (VDD supplied to ADC0)	Operating Mode, 200 ksps		400	900	μA
Power Supply Rejection			±0.3		mV/V

Note 1: Includes ADC offset, gain, and linearity variations.

Note 2: Represents one standard deviation from the mean.

## 6. VOLTAGE REFERENCE

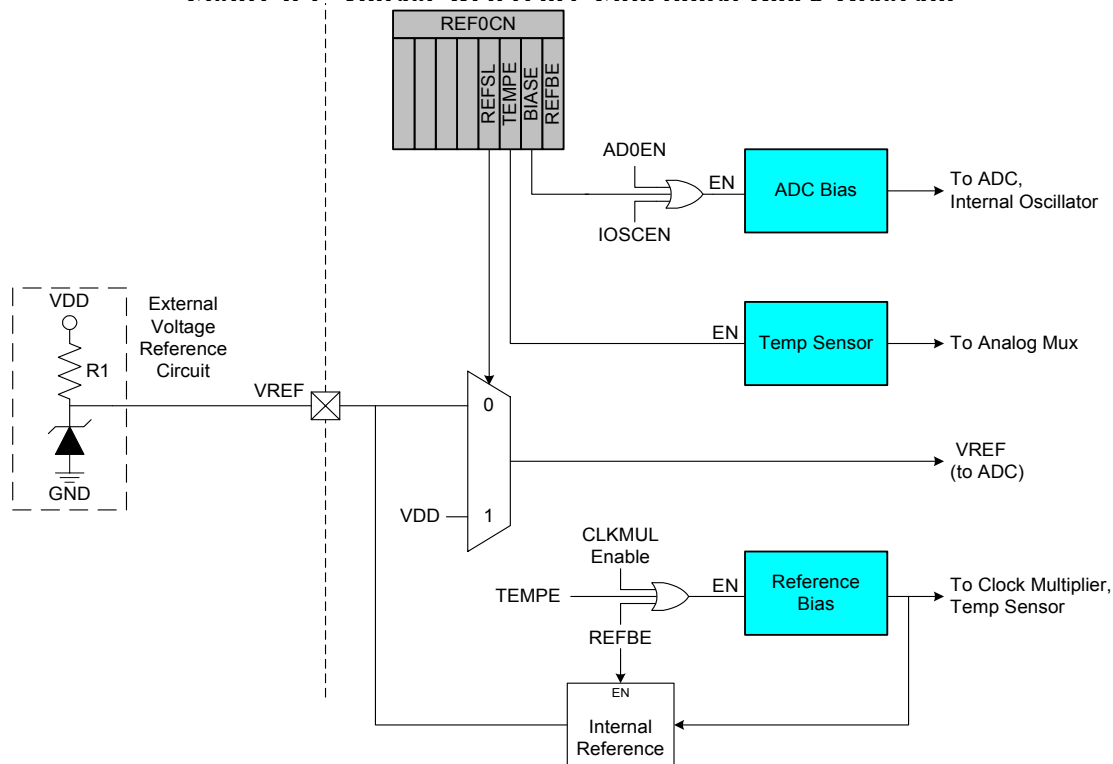
The Voltage reference MUX on C8051F320/1 devices is configurable to use an externally connected voltage reference, the internal reference voltage generator, or the power supply voltage VDD (see Figure 6.1). The REFSL bit in the Reference Control register (REF0CN) selects the reference source. For the internal reference or an external source, REFSL should be set to '0'; For VDD as the reference source, REFSL should be set to '1'.

The BIASE bit enables the internal ADC bias generator, which is used by the ADC and Internal Oscillator. This enable is forced to logic 1 when either of the aforementioned peripherals is enabled. The ADC bias generator may be enabled manually by writing a '1' to the BIASE bit in register REF0CN; see Figure 6.2 for REF0CN register details. The Reference bias generator (see Figure 6.1) is used by the Internal Voltage Reference, Temperature Sensor, and Clock Multiplier. The Reference bias is automatically enabled when any of the aforementioned peripherals are enabled. The electrical specifications for the voltage reference and bias circuits are given in Table 6.1.

**Important Note About the VREF Input:** Port pin P0.7 is used as the external VREF input. When using an external voltage reference, P0.7 should be configured as analog input and skipped by the Digital Crossbar. To configure P0.7 as analog input, set to '0' Bit7 in register P0MDIN. To configure the Crossbar to skip P0.7, set to '1' Bit7 in register POSKIP. Refer to **Section "14. Port Input/Output" on page 127** for complete Port I/O configuration details.

The temperature sensor connects to the ADC0 positive input multiplexer (see **Section "5.1. Analog Multiplexer" on page 40** for details). The TEMPE bit in register REF0CN enables/disables the temperature sensor. While disabled, the temperature sensor defaults to a high impedance state and any ADC0 measurements performed on the sensor result in meaningless data.

**Figure 6.1. Voltage Reference Functional Block Diagram**



**Figure 6.2. REF0CN: Reference Control Register**

R/W	R/W	R/W	R/W	R/W	R/W	R/W	R/W	Reset Value
-	-	-	-	REFSL	TEMPE	BIASE	REFBE	00000000
Bit7	Bit6	Bit5	Bit4	Bit3	Bit2	Bit1	Bit0	SFR Address: 0xD1

Bits7-3: UNUSED. Read = 00000b; Write = don't care.

Bit3: REFSL: Voltage Reference Select.  
This bit selects the source for the internal voltage reference.  
0: VREF pin used as voltage reference.  
1: VDD used as voltage reference.

Bit2: TEMPE: Temperature Sensor Enable Bit.  
0: Internal Temperature Sensor off.  
1: Internal Temperature Sensor on.

Bit1: BIASE: Internal Analog Bias Generator Enable Bit.  
0: Internal Bias Generator off.  
1: Internal Bias Generator on.

Bit0: REFBE: Internal Reference Buffer Enable Bit.  
0: Internal Reference Buffer disabled.  
1: Internal Reference Buffer enabled. Internal voltage reference driven on the VREF pin.

**Table 6.1. Voltage Reference Electrical Characteristics**

VDD = 3.0 V; -40°C TO +85°C UNLESS OTHERWISE SPECIFIED

PARAMETER	CONDITIONS	MIN	TYP	MAX	UNITS
<b>INTERNAL REFERENCE (REFBE = 1)</b>					
Output Voltage	25°C ambient	2.38	2.44	2.50	V
VREF Short-Circuit Current				10	mA
VREF Temperature Coefficient			15		ppm/°C
Load Regulation	Load = 0 to 200 μA to GND		1.5		ppm/μA
VREF Turn-on Time 1	4.7μF tantalum, 0.1μF ceramic bypass		2		ms
VREF Turn-on Time 2	0.1μF ceramic bypass		20		μs
VREF Turn-on Time 3	no bypass cap		10		μs
Power Supply Rejection			140		ppm/V
<b>EXTERNAL REFERENCE (REFBE = 0)</b>					
Input Voltage Range		0		VDD	V
Input Current	Sample Rate = 200 ksps; VREF = 3.0 V		12		μA
<b>BIAS GENERATORS</b>					
ADC Bias Generator	BIASE = '1'		100		μA
Reference Bias Generator			40		μA



## 7. COMPARATORS

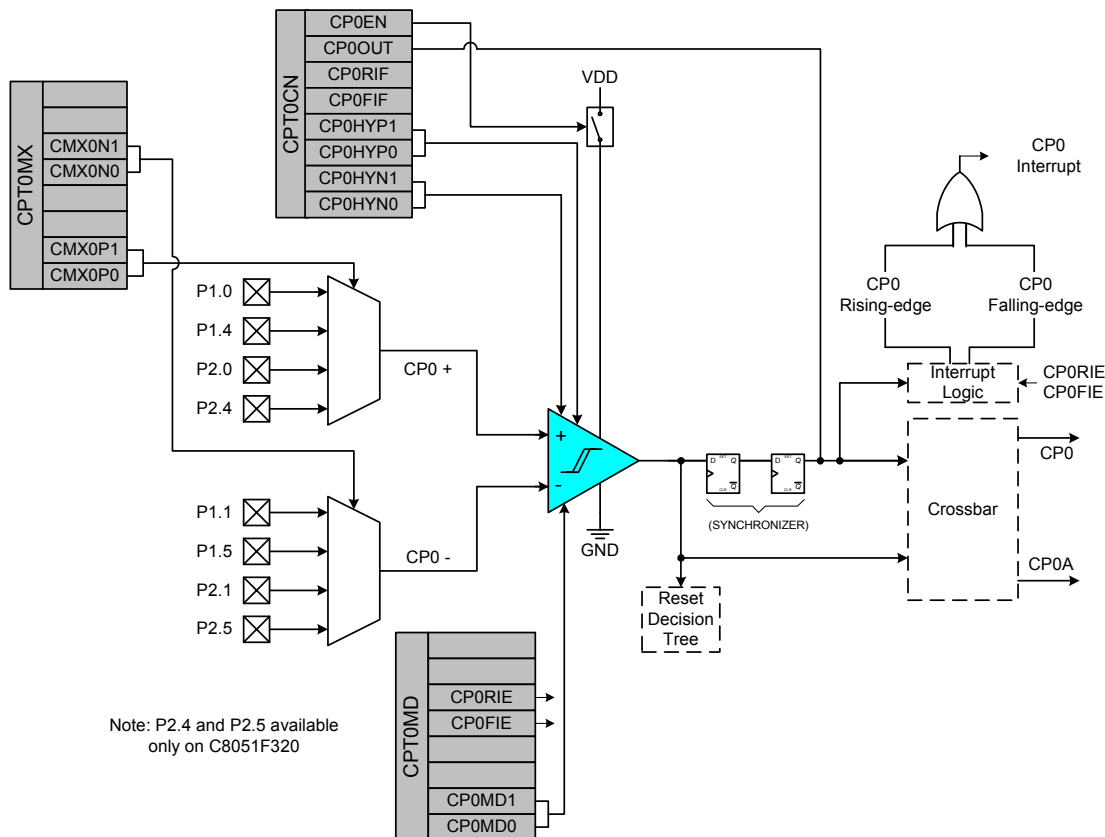
C8051F320/1 devices include two on-chip programmable voltage Comparators: Comparator0 is shown in Figure 7.1; Comparator1 is shown in Figure 7.2. The two Comparators operate identically with the following exceptions: (1) Their input selections differ as shown in Figure 7.1 and Figure 7.2; (2) Comparator0 can be used as a reset source.

Each Comparator offers programmable response time and hysteresis, an analog input multiplexer, and two outputs that are optionally available at the Port pins: a synchronous “latched” output (CP0, CP1), or an asynchronous “raw” output (CP0A, CP1A). The asynchronous signal is available even when the system clock is not active. This allows the Comparators to operate and generate an output with the device in STOP mode. When assigned to a Port pin, the Comparator outputs may be configured as open drain or push-pull (see **Section “14.2. Port I/O Initialization” on page 131**). Comparator0 may also be used as a reset source (see **Section “10.5. Comparator0 Reset” on page 102**).

The Comparator0 inputs are selected in the CPT0MX register (Figure 7.5). The CMX0P1-CMX0P0 bits select the Comparator0 positive input; the CMX0N1-CMX0N0 bits select the Comparator0 negative input. The Comparator1 inputs are selected in the CPT1MX register (Figure 7.8). The CMX1P1-CMX1P0 bits select the Comparator1 positive input; the CMX1N1-CMX1N0 bits select the Comparator1 negative input.

**Important Note About Comparator Inputs:** The Port pins selected as Comparator inputs should be configured as analog inputs in their associated Port configuration register, and configured to be skipped by the Crossbar (for details on Port configuration, see **Section “14.3. General Purpose Port I/O” on page 134**).

**Figure 7.1. Comparator0 Functional Block Diagram**



# C8051F320/1

Comparator outputs can be polled in software, used as an interrupt source, and/or routed to a Port pin. When routed to a Port pin, Comparator outputs are available asynchronous or synchronous to the system clock; the asynchronous output is available even in STOP mode (with no system clock active). When disabled, the Comparator output (if assigned to a Port I/O pin via the Crossbar) defaults to the logic low state, and supply current falls to less than 100 nA. See **Section “14.1. Priority Crossbar Decoder” on page 129** for details on configuring Comparator outputs via the digital Crossbar. Comparator inputs can be externally driven from -0.25 V to (VDD) + 0.25 V without damage or upset. The complete Comparator electrical specifications are given in Table 7.1.

Comparator response time may be configured in software via the CPTnMD registers (see Figure 7.6 and Figure 7.9). Selecting a longer response time reduces the Comparator supply current. See Table 7.1 for complete timing and supply current specifications.

**Figure 7.2. Comparator1 Functional Block Diagram**

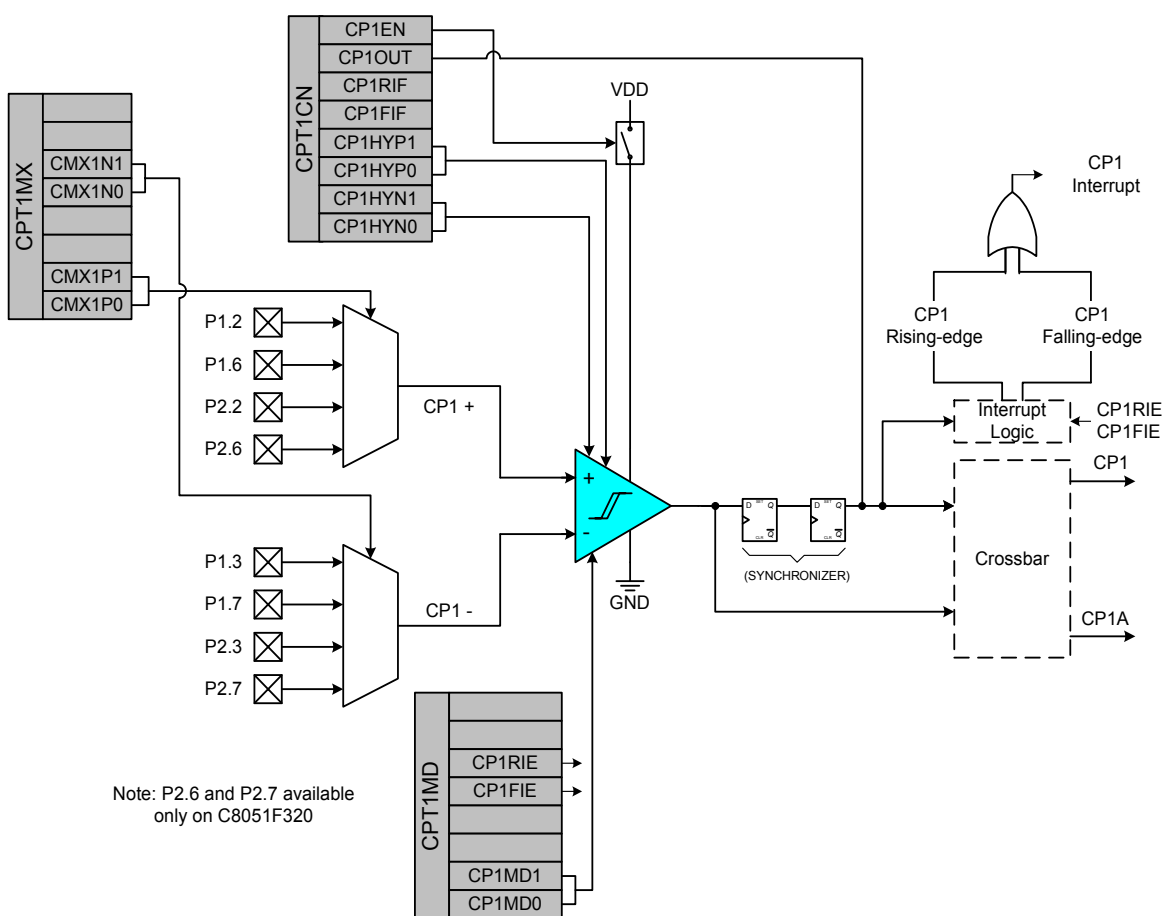
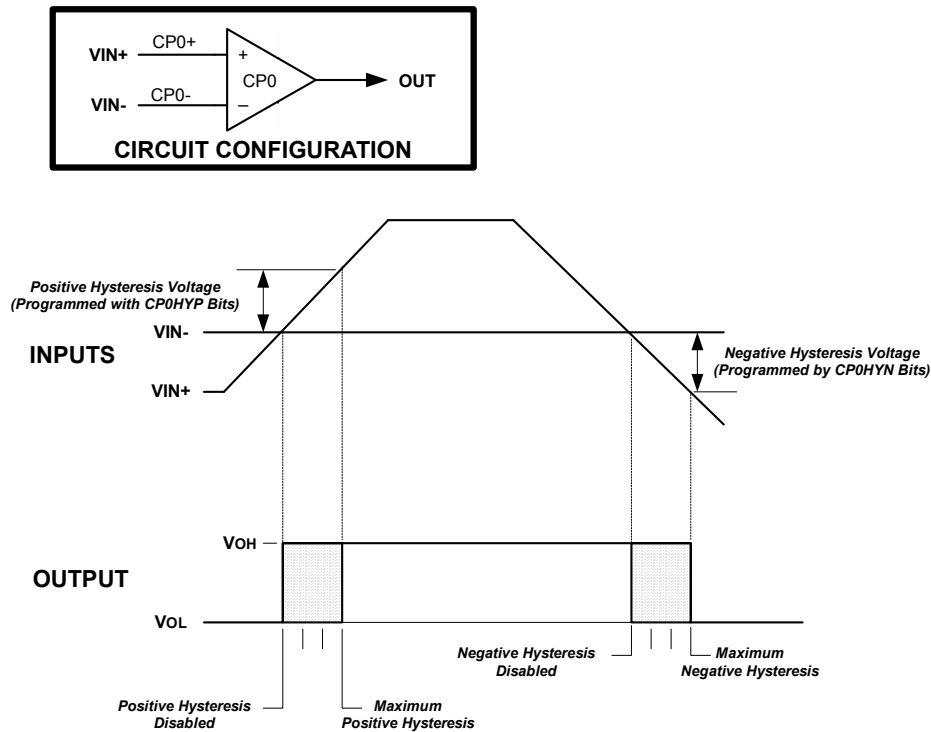


Figure 7.3. Comparator Hysteresis Plot



Comparator hysteresis is programmed using Bits3-0 in the Comparator Control Register CPTnCN (shown in Figure 7.4 and Figure 7.7). The amount of negative hysteresis voltage is determined by the settings of the CPnHYN bits. As shown in Figure 7.3, settings of 20, 10 or 5 mV of negative hysteresis can be programmed, or negative hysteresis can be disabled. In a similar way, the amount of positive hysteresis is determined by the setting of the CPnHYP bits.

Comparator interrupts can be generated on both rising-edge and falling-edge output transitions. (For Interrupt enable and priority control, see [Section “8.3. Interrupt Handler” on page 58](#).) The CPnFIF flag is set to ‘1’ upon a Comparator falling-edge, and the CPnRIF flag is set to ‘1’ upon the Comparator rising-edge. Once set, these bits remain set until cleared by software. The output state of the Comparator can be obtained at any time by reading the CPnOUT bit. The Comparator is enabled by setting the CPnEN bit to ‘1’, and is disabled by clearing this bit to ‘0’.

**Figure 7.4. CPT0CN: Comparator0 Control Register**

R/W	R	R/W	R/W	R/W	R/W	R/W	R/W	Reset Value
CP0EN	CP0OUT	CP0RIF	CP0FIF	CP0HYP1	CP0HYP0	CP0HYN1	CP0HYN0	00000000
Bit7	Bit6	Bit5	Bit4	Bit3	Bit2	Bit1	Bit0	SFR Address: 0x9B
<p>Bit7: CP0EN: Comparator0 Enable Bit. 0: Comparator0 Disabled. 1: Comparator0 Enabled.</p> <p>Bit6: CP0OUT: Comparator0 Output State Flag. 0: Voltage on CP0+ &lt; CP0-. 1: Voltage on CP0+ &gt; CP0-.</p> <p>Bit5: CP0RIF: Comparator0 Rising-Edge Flag. 0: No Comparator0 Rising Edge has occurred since this flag was last cleared. 1: Comparator0 Rising Edge has occurred.</p> <p>Bit4: CP0FIF: Comparator0 Falling-Edge Flag. 0: No Comparator0 Falling-Edge has occurred since this flag was last cleared. 1: Comparator0 Falling-Edge Interrupt has occurred.</p> <p>Bits3-2: CP0HYP1-0: Comparator0 Positive Hysteresis Control Bits. 00: Positive Hysteresis Disabled. 01: Positive Hysteresis = 5 mV. 10: Positive Hysteresis = 10 mV. 11: Positive Hysteresis = 20 mV.</p> <p>Bits1-0: CP0HYN1-0: Comparator0 Negative Hysteresis Control Bits. 00: Negative Hysteresis Disabled. 01: Negative Hysteresis = 5 mV. 10: Negative Hysteresis = 10 mV. 11: Negative Hysteresis = 20 mV.</p>								

**Figure 7.5. CPT0MX: Comparator0 MUX Selection Register**

R/W	R/W	R/W	R/W	R/W	R/W	R/W	R/W	Reset Value
-	-	CMX0N1	CMX0N0	-	-	CMX0P1	CMX0P0	00000000
Bit7	Bit6	Bit5	Bit4	Bit3	Bit2	Bit1	Bit0	SFR Address: 0x9F

Bits7-6: UNUSED. Read = 00b, Write = don't care.  
 Bits5-4: CMX0N1-CMX0N0: Comparator0 Negative Input MUX Select.  
 These bits select which Port pin is used as the Comparator0 negative input.

CMX0N1	CMX0N0	Negative Input
0	0	P1.1
0	1	P1.5
1	0	P2.1
1	1	P2.5 <sup>†</sup>

Bits3-2: UNUSED. Read = 00b, Write = don't care.  
 Bits1-0: CMX0P1-CMX0P0: Comparator0 Positive Input MUX Select.  
 These bits select which Port pin is used as the Comparator0 positive input.

CMX0P1	CMX0P0	Positive Input
0	0	P1.0
0	1	P1.4
1	0	P2.0
1	1	P2.4 <sup>†</sup>

<sup>†</sup>Note: P2.4 and P2.5 available only on C8051F320 devices; selection reserved on C8051F321 devices.

**Figure 7.6. CPT0MD: Comparator0 Mode Selection Register**

R/W	R/W	R/W	R/W	R/W	R/W	R/W	R/W	Reset Value
-	-	CP0RIE	CP0FIE	-	-	CP0MD1	CP0MD0	00000010
Bit7	Bit6	Bit5	Bit4	Bit3	Bit2	Bit1	Bit0	SFR Address: 0x9D

Bits7-6: UNUSED. Read = 00b. Write = don't care.

Bit5: CP0RIE: Comparator0 Rising-Edge Interrupt Enable.  
0: Comparator0 rising-edge interrupt disabled.  
1: Comparator0 rising-edge interrupt enabled.

Bit4: CP0FIE: Comparator0 Falling-Edge Interrupt Enable.  
0: Comparator0 falling-edge interrupt disabled.  
1: Comparator0 falling-edge interrupt enabled.

Bits3-2: UNUSED. Read = 00b. Write = don't care.

Bits1-0: CP0MD1-CP0MD0: Comparator0 Mode Select  
These bits select the response time for Comparator0.

Mode	CP0MD1	CP0MD0	CP0 Response Time (TYP)
0	0	0	100 ns
1	0	1	175 ns
2	1	0	320 ns
3	1	1	1050 ns

**Figure 7.7. CPT1CN: Comparator1 Control Register**

R/W	R	R/W	R/W	R/W	R/W	R/W	R/W	Reset Value
CP1EN	CP1OUT	CP1RIF	CP1FIF	CP1HYP1	CP1HYP0	CP1HYN1	CP1HYN0	00000000
Bit7	Bit6	Bit5	Bit4	Bit3	Bit2	Bit1	Bit0	SFR Address: 0x9A
<p>Bit7: CP1EN: Comparator1 Enable Bit. 0: Comparator1 Disabled. 1: Comparator1 Enabled.</p> <p>Bit6: CP1OUT: Comparator1 Output State Flag. 0: Voltage on CP1+ &lt; CP1-. 1: Voltage on CP1+ &gt; CP1-.</p> <p>Bit5: CP1RIF: Comparator1 Rising-Edge Flag. 0: No Comparator1 Rising Edge has occurred since this flag was last cleared. 1: Comparator1 Rising Edge has occurred.</p> <p>Bit4: CP1FIF: Comparator1 Falling-Edge Flag. 0: No Comparator1 Falling-Edge has occurred since this flag was last cleared. 1: Comparator1 Falling-Edge has occurred.</p> <p>Bits3-2: CP1HYP1-0: Comparator1 Positive Hysteresis Control Bits. 00: Positive Hysteresis Disabled. 01: Positive Hysteresis = 5 mV. 10: Positive Hysteresis = 10 mV. 11: Positive Hysteresis = 20 mV.</p> <p>Bits1-0: CP1HYN1-0: Comparator1 Negative Hysteresis Control Bits. 00: Negative Hysteresis Disabled. 01: Negative Hysteresis = 5 mV. 10: Negative Hysteresis = 10 mV. 11: Negative Hysteresis = 20 mV.</p>								

**Figure 7.8. CPT1MX: Comparator1 MUX Selection Register**

R/W	R/W	R/W	R/W	R/W	R/W	R/W	R/W	Reset Value
-	-	CMX1N1	CMX1N0	-	-	CMX1P1	CMX1P0	00000000
Bit7	Bit6	Bit5	Bit4	Bit3	Bit2	Bit1	Bit0	SFR Address: 0x9E

Bits7-6: UNUSED. Read = 00b, Write = don't care.  
 Bits5-4: CMX1N1-CMX1N0: Comparator1 Negative Input MUX Select.  
 These bits select which Port pin is used as the Comparator1 negative input.

CMX1N1	CMX1N0	Negative Input
0	0	P1.3
0	1	P1.7
1	0	P2.3
1	1	P2.7 <sup>†</sup>

Bits3-2: UNUSED. Read = 00b, Write = don't care.  
 Bits1-0: CMX1P1-CMX1P0: Comparator1 Positive Input MUX Select.  
 These bits select which Port pin is used as the Comparator1 positive input.

CMX1P1	CMX1P0	Positive Input
0	0	P1.2
0	1	P1.6
1	0	P2.2
1	1	P2.6 <sup>†</sup>

<sup>†</sup>Note: P2.6 and P2.7 available only on C8051F320 devices; selection reserved on C8051F321 devices.



**Figure 7.9. CPT1MD: Comparator1 Mode Selection Register**

R/W	R/W	R/W	R/W	R/W	R/W	R/W	R/W	Reset Value
-	-	CP1RIE	CP1FIE	-	-	CP1MD1	CP1MD0	00000010
Bit7	Bit6	Bit5	Bit4	Bit3	Bit2	Bit1	Bit0	SFR Address: 0x9C

Bits7-6: UNUSED. Read = 00b, Write = don't care.

Bit5: CP1RIE: Comparator1 Rising-Edge Interrupt Enable.  
0: Comparator1 rising-edge interrupt disabled.  
1: Comparator1 rising-edge interrupt enabled.

Bit4: CP1FIE: Comparator1 Falling-Edge Interrupt Enable.  
0: Comparator1 falling-edge interrupt disabled.  
1: Comparator1 falling-edge interrupt enabled.

Bits1-0: CP1MD1-CP1MD0: Comparator1 Mode Select.  
These bits select the response time for Comparator1.

Mode	CP1MD1	CP1MD0	CP1 Response Time (TYP)
0	0	0	100 ns
1	0	1	175 ns
2	1	0	320 ns
3	1	1	1050 ns

# C8051F320/1

**Table 7.1. Comparator Electrical Characteristics**

VDD = 3.0 V, -40°C to +85°C unless otherwise noted.

All specifications apply to both Comparator0 and Comparator1 unless otherwise noted.

PARAMETER	CONDITIONS	MIN	TYP	MAX	UNITS
Response Time: Mode 0, Vcm <sup>†</sup> = 1.5 V	CP0+ - CP0- = 100 mV		100		ns
	CP0+ - CP0- = -100 mV		250		ns
Response Time: Mode 1, Vcm <sup>†</sup> = 1.5 V	CP0+ - CP0- = 100 mV		175		ns
	CP0+ - CP0- = -100 mV		500		ns
Response Time: Mode 2, Vcm <sup>†</sup> = 1.5 V	CP0+ - CP0- = 100 mV		320		ns
	CP0+ - CP0- = -100 mV		1100		ns
Response Time: Mode 3, Vcm <sup>†</sup> = 1.5 V	CP0+ - CP0- = 100 mV		1050		ns
	CP0+ - CP0- = -100 mV		5200		ns
Common-Mode Rejection Ratio			1.5	4	mV/V
Positive Hysteresis 1	CP0HYP1-0 = 00		0	1	mV
Positive Hysteresis 2	CP0HYP1-0 = 01	2	5	10	mV
Positive Hysteresis 3	CP0HYP1-0 = 10	7	10	20	mV
Positive Hysteresis 4	CP0HYP1-0 = 11	15	20	30	mV
Negative Hysteresis 1	CP0HYN1-0 = 00		0	1	mV
Negative Hysteresis 2	CP0HYN1-0 = 01	2	5	10	mV
Negative Hysteresis 3	CP0HYN1-0 = 10	7	10	20	mV
Negative Hysteresis 4	CP0HYN1-0 = 11	15	20	30	mV
Inverting or Non-Inverting Input Voltage Range		-0.25		VDD + 0.25	V
Input Capacitance			3		pF
Input Bias Current			0.001		nA
Input Offset Voltage		-5		+5	mV
<b>POWER SUPPLY</b>					
Power Supply Rejection			0.1		mV/V
Power-up Time			10		μs
Supply Current at DC	Mode 0		7.6		μA
	Mode 1		3.2		μA
	Mode 2		1.3		μA
	Mode 3		0.4		μA

<sup>†</sup>Vcm is the common-mode voltage on CP0+ and CP0-.

---

## 8. VOLTAGE REGULATOR (REG0)

C8051F320/1 devices include a 5 V-to-3 V voltage regulator (REG0). When enabled, the REG0 output appears on the VDD pin and can be used to power external devices. REG0 can be enabled/disabled by software using bit REGEN in register REG0CN. See Table 8.1 for REG0 electrical characteristics.

Note that the VBUS signal must be connected to the VBUS pin when using the device in a USB network. The VBUS signal should only be connected to the REGIN pin when operating the device as a bus-powered function. REG0 configuration options are shown in Figure 8.1 - Figure 8.4.

## 8.1. Regulator Mode Selection

REG0 offers a low power mode intended for use when the device is in suspend mode. In this low power mode, the REG0 output remains as specified; however the REG0 dynamic performance (response time) is degraded. See Table 8.1 for normal and low power mode supply current specifications. The REG0 mode selection is controlled via the REGMOD bit in register REG0CN.

## 8.2. VBUS Detection

When the USB Function Controller is used (see section **Section “15. Universal Serial Bus Controller (USB0)” on page 143**), the VBUS signal should be connected to the VBUS pin. The VBSTAT bit (register REG0CN) indicates the current logic level of the VBUS signal. If enabled, a VBUS interrupt will be generated when the VBUS signal matches the polarity selected by the VBPOL bit in register REG0CN. The VBUS interrupt is level-sensitive, and has no associated interrupt pending flag. The VBUS interrupt will be active as long as the VBUS signal matches the polarity selected by VBPOL. See Table 8.1 for VBUS input parameters.

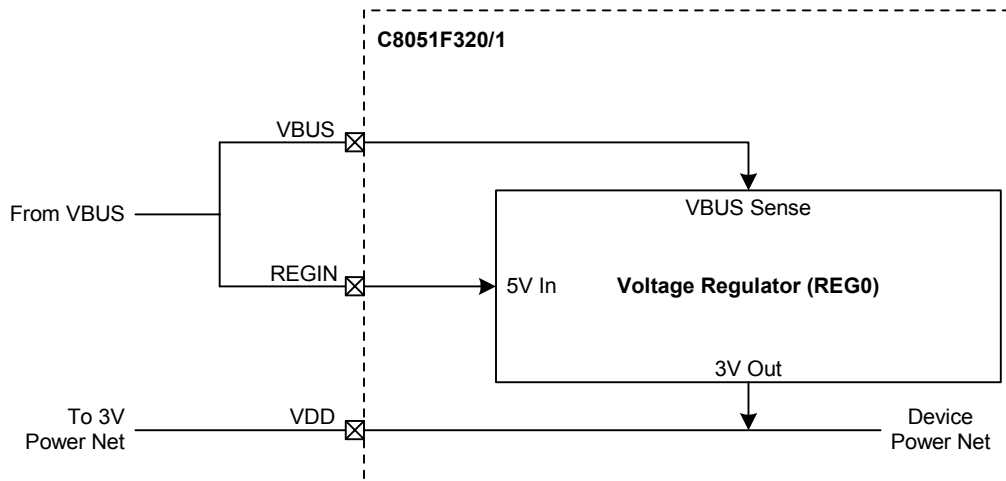
**Important Note:** When USB is selected as a reset source, a system reset will be generated when the VBUS signal matches the polarity selected by the VBPOL bit. See **Section “10. Reset Sources” on page 99** for details on selecting USB as a reset source.

**Table 8.1. Voltage Regulator Electrical Specifications**

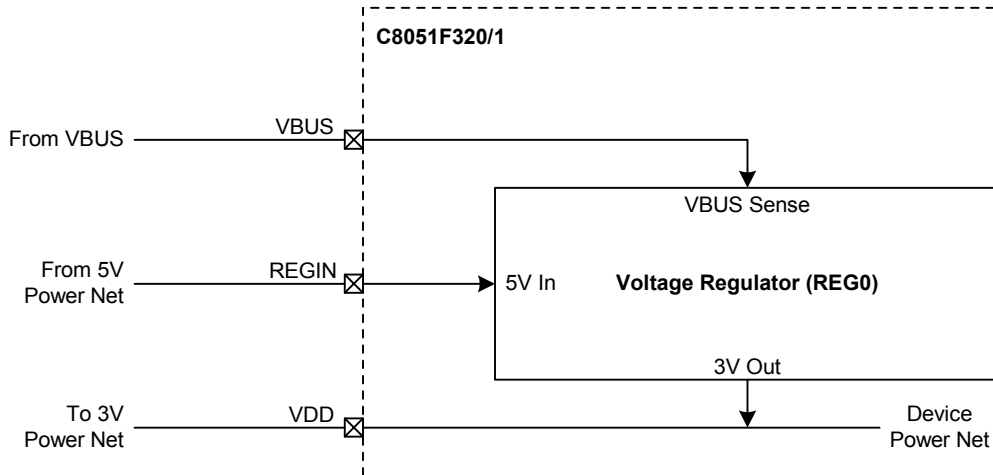
VDD = 3.0 V; -40°C to +85°C unless otherwise specified

PARAMETER	CONDITIONS	MIN	TYP	MAX	UNITS
Input Voltage Range		4.0		5.25	V
Output Voltage	Output Current = 1 to 100 mA	3.0	3.3	3.6	V
VBUS Detection Input Threshold		1.0	1.8	4.0	V
Bias Current	Normal Mode (REGMOD = ‘0’)		90	TBD	μA
	Low Power Mode (REGMOD = ‘1’)		60	TBD	

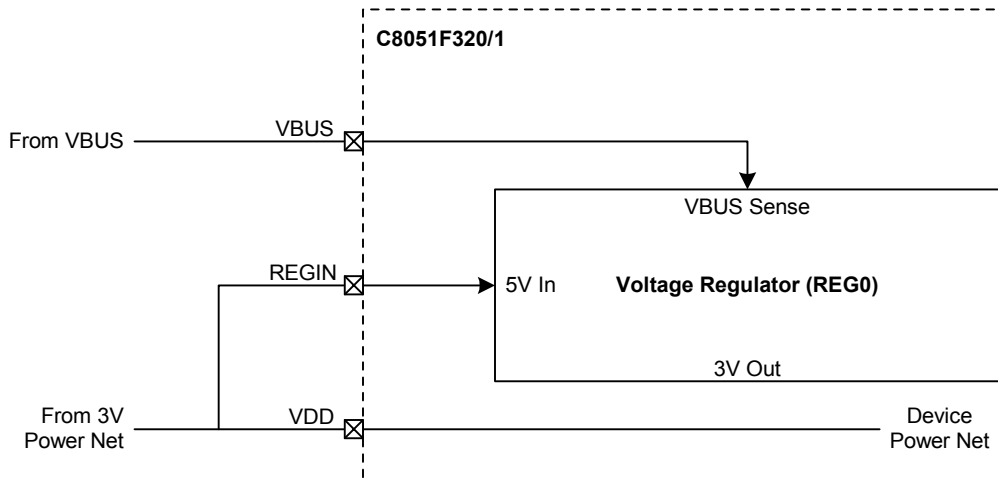
**Figure 8.1. REG0 Configuration: USB Bus-Powered**



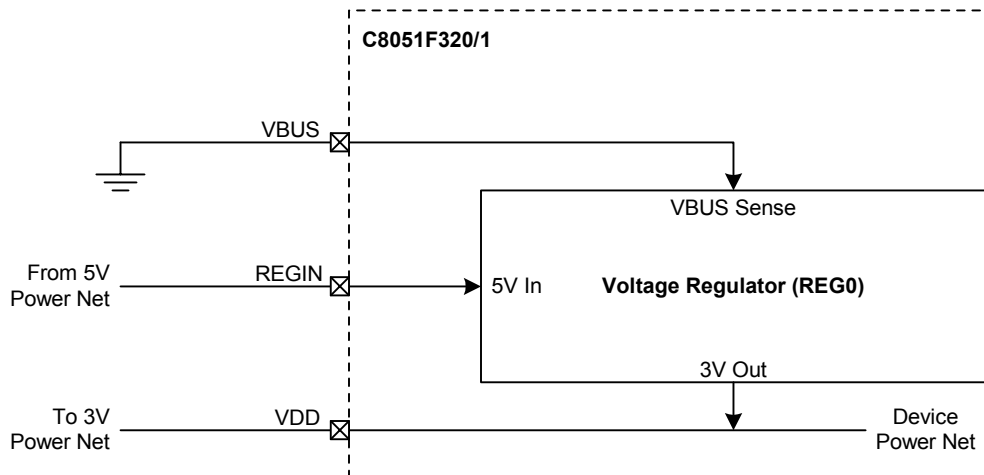
**Figure 8.2. REG0 Configuration: USB Self-Powered**



**Figure 8.3. REG0 Configuration: USB Self-Powered, Regulator Disabled**



**Figure 8.4. REG0 Configuration: No USB Connection**



**Figure 8.5. REG0CN: Voltage Regulator Control**

R/W	R	R/W	R/W	R/W	R/W	R/W	R/W	Reset Value
REGDIS	VBSTAT	VBPOL	REGMOD	Reserved	Reserved	Reserved	Reserved	00000000
Bit7	Bit6	Bit5	Bit4	Bit3	Bit2	Bit1	Bit0	SFR Address: 0xC9
Bit7:	REGDIS: Voltage Regulator Disable. 0: Voltage Regulator Enabled. 1: Voltage Regulator Disabled.							
Bit6:	VBSTAT: VBUS Signal Status. 0: VBUS signal currently absent (device not attached to USB network). 1: VBUS signal currently present (device attached to USB network).							
Bit5:	VBPOL: VBUS Interrupt Polarity Select. This bit selects the VBUS interrupt polarity. 0: VBUS interrupt active when VBUS is low. 1: VBUS interrupt active when VBUS is high.							
Bit4:	REGMOD: Voltage Regulator Mode Select. This bit selects the Voltage Regulator mode. When REGMOD is set to '1', the voltage regulator operates in low power (suspend) mode. 0: USB0 Voltage Regulator in normal mode. 1: USB0 Voltage Regulator in low power mode.							
Bits3-0:	Reserved. Read = 0000b. Must Write = 0000b.							



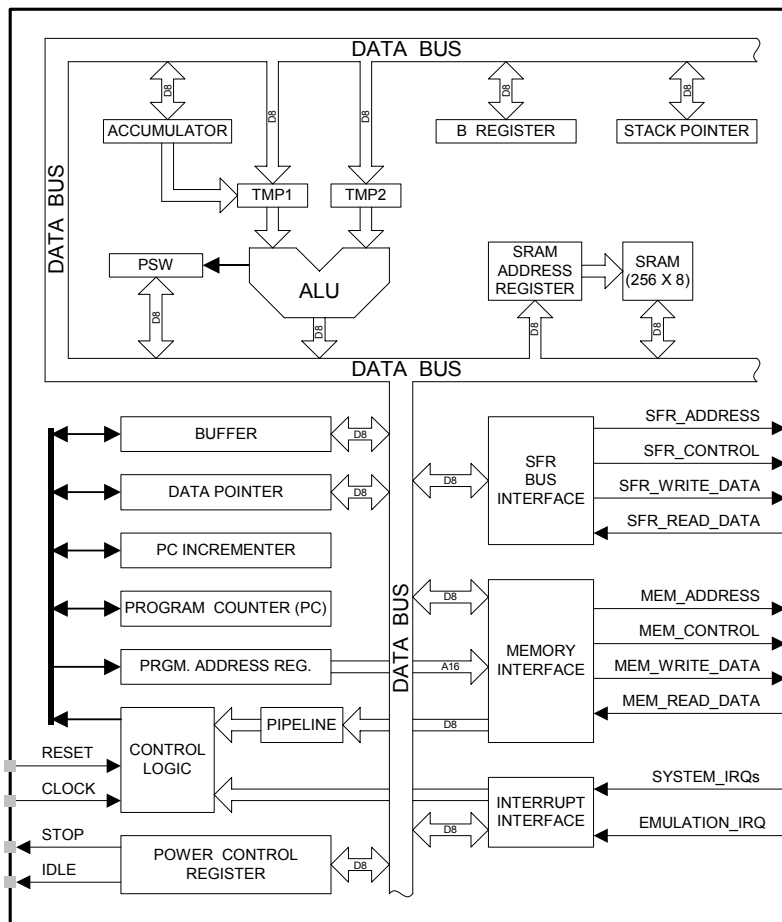
## 9. CIP-51 MICROCONTROLLER

The MCU system controller core is the CIP-51 microcontroller. The CIP-51 is fully compatible with the MCS-51™ instruction set; standard 803x/805x assemblers and compilers can be used to develop software. The MCU family has a superset of all the peripherals included with a standard 8051. Included are four 16-bit counter/timers (see description in [Section 19](#)), an enhanced full-duplex UART (see description in [Section 17](#)), an Enhanced SPI (see description in [Section 18](#)), 256 bytes of internal RAM, 128 byte Special Function Register (SFR) address space ([Section 9.2.6](#)), and 25 Port I/O (see description in [Section 14](#)). The CIP-51 also includes on-chip debug hardware (see description in [Section 21](#)), and interfaces directly with the analog and digital subsystems providing a complete data acquisition or control-system solution in a single integrated circuit.

The CIP-51 Microcontroller core implements the standard 8051 organization and peripherals as well as additional custom peripherals and functions to extend its capability (see Figure 9.1 for a block diagram). The CIP-51 includes the following features:

- Fully Compatible with MCS-51 Instruction Set
- 25 MIPS Peak Throughput with 25 MHz Clock
- 0 to 25 MHz Clock Frequency
- 256 Bytes of Internal RAM
- 25 Port I/O
- Extended Interrupt Handler
- Reset Input
- Power Management Modes
- On-chip Debug Logic
- Program and Data Memory Security

**Figure 9.1. CIP-51 Block Diagram**



# C8051F320/1

## Performance

The CIP-51 employs a pipelined architecture that greatly increases its instruction throughput over the standard 8051 architecture. In a standard 8051, all instructions except for MUL and DIV take 12 or 24 system clock cycles to execute, and usually have a maximum system clock of 12 MHz. By contrast, the CIP-51 core executes 70% of its instructions in one or two system clock cycles, with no instructions taking more than eight system clock cycles.

With the CIP-51's maximum system clock at 25 MHz, it has a peak throughput of 25 MIPS. The CIP-51 has a total of 109 instructions. The table below shows the total number of instructions that for execution time.

Clocks to Execute	1	2	2/3	3	3/4	4	4/5	5	8
Number of Instructions	26	50	5	14	7	3	1	2	1

## Programming and Debugging Support

In-system programming of the FLASH program memory and communication with on-chip debug support logic is accomplished via the Silicon Labs 2-Wire Development Interface (C2). Note that the re-programmable FLASH can also be read and changed a single byte at a time by the application software using the MOV<sub>C</sub> and MOV<sub>X</sub> instructions. This feature allows program memory to be used for non-volatile data storage as well as updating program code under software control.

The on-chip debug support logic facilitates full speed in-circuit debugging, allowing the setting of hardware breakpoints, starting, stopping and single stepping through program execution (including interrupt service routines), examination of the program's call stack, and reading/writing the contents of registers and memory. This method of on-chip debugging is completely non-intrusive, requiring no RAM, Stack, timers, or other on-chip resources. C2 details can be found in [Section "21. C2 Interface" on page 253](#).

The CIP-51 is supported by development tools from Silicon Labs and third party vendors. Silicon Labs provides an integrated development environment (IDE) including editor, macro assembler, debugger and programmer. The IDE's debugger and programmer interface to the CIP-51 via the C2 interface to provide fast and efficient in-system device programming and debugging. Third party macro assemblers and C compilers are also available.

## 9.1. Instruction Set

The instruction set of the CIP-51 System Controller is fully compatible with the standard MCS-51™ instruction set. Standard 8051 development tools can be used to develop software for the CIP-51. All CIP-51 instructions are the binary and functional equivalent of their MCS-51™ counterparts, including opcodes, addressing modes and effect on PSW flags. However, instruction timing is different than that of the standard 8051.

### 9.1.1. Instruction and CPU Timing

In many 8051 implementations, a distinction is made between machine cycles and clock cycles, with machine cycles varying from 2 to 12 clock cycles in length. However, the CIP-51 implementation is based solely on clock cycle timing. All instruction timings are specified in terms of clock cycles.

Due to the pipelined architecture of the CIP-51, most instructions execute in the same number of clock cycles as there are program bytes in the instruction. Conditional branch instructions take one less clock cycle to complete when the branch is not taken as opposed to when the branch is taken. Table 9.1 is the CIP-51 Instruction Set Summary, which includes the mnemonic, number of bytes, and number of clock cycles for each instruction.

### 9.1.2. MOVX Instruction and Program Memory

The MOVX instruction is typically used to access external data memory (Note: the C8051F320/1 does not support off-chip data or program memory). In the CIP-51, the MOVX write instruction is used to access external RAM (XRAM) and the on-chip program memory space implemented as re-programmable FLASH memory. The FLASH access feature provides a mechanism for the CIP-51 to update program code and use the program memory space for non-volatile data storage. Refer to [Section “11. FLASH Memory” on page 107](#) for further details.

**Table 9.1. CIP-51 Instruction Set Summary**

Mnemonic	Description	Bytes	Clock Cycles
<b>ARITHMETIC OPERATIONS</b>			
ADD A, Rn	Add register to A	1	1
ADD A, direct	Add direct byte to A	2	2
ADD A, @Ri	Add indirect RAM to A	1	2
ADD A, #data	Add immediate to A	2	2
ADDC A, Rn	Add register to A with carry	1	1
ADDC A, direct	Add direct byte to A with carry	2	2
ADDC A, @Ri	Add indirect RAM to A with carry	1	2
ADDC A, #data	Add immediate to A with carry	2	2
SUBB A, Rn	Subtract register from A with borrow	1	1
SUBB A, direct	Subtract direct byte from A with borrow	2	2
SUBB A, @Ri	Subtract indirect RAM from A with borrow	1	2
SUBB A, #data	Subtract immediate from A with borrow	2	2
INC A	Increment A	1	1
INC Rn	Increment register	1	1
INC direct	Increment direct byte	2	2
INC @Ri	Increment indirect RAM	1	2
DEC A	Decrement A	1	1
DEC Rn	Decrement register	1	1
DEC direct	Decrement direct byte	2	2
DEC @Ri	Decrement indirect RAM	1	2
INC DPTR	Increment Data Pointer	1	1

**Table 9.1. CIP-51 Instruction Set Summary**

Mnemonic	Description	Bytes	Clock Cycles
MUL AB	Multiply A and B	1	4
DIV AB	Divide A by B	1	8
DA A	Decimal adjust A	1	1
<b>LOGICAL OPERATIONS</b>			
ANL A, Rn	AND Register to A	1	1
ANL A, direct	AND direct byte to A	2	2
ANL A, @Ri	AND indirect RAM to A	1	2
ANL A, #data	AND immediate to A	2	2
ANL direct, A	AND A to direct byte	2	2
ANL direct, #data	AND immediate to direct byte	3	3
ORL A, Rn	OR Register to A	1	1
ORL A, direct	OR direct byte to A	2	2
ORL A, @Ri	OR indirect RAM to A	1	2
ORL A, #data	OR immediate to A	2	2
ORL direct, A	OR A to direct byte	2	2
ORL direct, #data	OR immediate to direct byte	3	3
XRL A, Rn	Exclusive-OR Register to A	1	1
XRL A, direct	Exclusive-OR direct byte to A	2	2
XRL A, @Ri	Exclusive-OR indirect RAM to A	1	2
XRL A, #data	Exclusive-OR immediate to A	2	2
XRL direct, A	Exclusive-OR A to direct byte	2	2
XRL direct, #data	Exclusive-OR immediate to direct byte	3	3
CLR A	Clear A	1	1
CPL A	Complement A	1	1
RL A	Rotate A left	1	1
RLC A	Rotate A left through Carry	1	1
RR A	Rotate A right	1	1
RRC A	Rotate A right through Carry	1	1
SWAP A	Swap nibbles of A	1	1
<b>DATA TRANSFER</b>			
MOV A, Rn	Move Register to A	1	1
MOV A, direct	Move direct byte to A	2	2
MOV A, @Ri	Move indirect RAM to A	1	2
MOV A, #data	Move immediate to A	2	2
MOV Rn, A	Move A to Register	1	1
MOV Rn, direct	Move direct byte to Register	2	2
MOV Rn, #data	Move immediate to Register	2	2
MOV direct, A	Move A to direct byte	2	2
MOV direct, Rn	Move Register to direct byte	2	2
MOV direct, direct	Move direct byte to direct byte	3	3
MOV direct, @Ri	Move indirect RAM to direct byte	2	2
MOV direct, #data	Move immediate to direct byte	3	3
MOV @Ri, A	Move A to indirect RAM	1	2
MOV @Ri, direct	Move direct byte to indirect RAM	2	2
MOV @Ri, #data	Move immediate to indirect RAM	2	2

Table 9.1. CIP-51 Instruction Set Summary

Mnemonic	Description	Bytes	Clock Cycles
MOV DPTR, #data16	Load DPTR with 16-bit constant	3	3
MOVC A, @A+DPTR	Move code byte relative DPTR to A	1	3
MOVC A, @A+PC	Move code byte relative PC to A	1	3
MOVX A, @Ri	Move external data (8-bit address) to A	1	3
MOVX @Ri, A	Move A to external data (8-bit address)	1	3
MOVX A, @DPTR	Move external data (16-bit address) to A	1	3
MOVX @DPTR, A	Move A to external data (16-bit address)	1	3
PUSH direct	Push direct byte onto stack	2	2
POP direct	Pop direct byte from stack	2	2
XCH A, Rn	Exchange Register with A	1	1
XCH A, direct	Exchange direct byte with A	2	2
XCH A, @Ri	Exchange indirect RAM with A	1	2
XCHD A, @Ri	Exchange low nibble of indirect RAM with A	1	2
<b>BOOLEAN MANIPULATION</b>			
CLR C	Clear Carry	1	1
CLR bit	Clear direct bit	2	2
SETB C	Set Carry	1	1
SETB bit	Set direct bit	2	2
CPL C	Complement Carry	1	1
CPL bit	Complement direct bit	2	2
ANL C, bit	AND direct bit to Carry	2	2
ANL C, /bit	AND complement of direct bit to Carry	2	2
ORL C, bit	OR direct bit to carry	2	2
ORL C, /bit	OR complement of direct bit to Carry	2	2
MOV C, bit	Move direct bit to Carry	2	2
MOV bit, C	Move Carry to direct bit	2	2
JC rel	Jump if Carry is set	2	2/3
JNC rel	Jump if Carry is not set	2	2/3
JB bit, rel	Jump if direct bit is set	3	3/4
JNB bit, rel	Jump if direct bit is not set	3	3/4
JBC bit, rel	Jump if direct bit is set and clear bit	3	3/4
<b>PROGRAM BRANCHING</b>			
ACALL addr11	Absolute subroutine call	2	3
LCALL addr16	Long subroutine call	3	4
RET	Return from subroutine	1	5
RETI	Return from interrupt	1	5
AJMP addr11	Absolute jump	2	3
LJMP addr16	Long jump	3	4
SJMP rel	Short jump (relative address)	2	3
JMP @A+DPTR	Jump indirect relative to DPTR	1	3
JZ rel	Jump if A equals zero	2	2/3
JNZ rel	Jump if A does not equal zero	2	2/3
CJNE A, direct, rel	Compare direct byte to A and jump if not equal	3	3/4
CJNE A, #data, rel	Compare immediate to A and jump if not equal	3	3/4
CJNE Rn, #data, rel	Compare immediate to Register and jump if not equal	3	3/4

**Table 9.1. CIP-51 Instruction Set Summary**

Mnemonic	Description	Bytes	Clock Cycles
CJNE @Ri, #data, rel	Compare immediate to indirect and jump if not equal	3	4/5
DJNZ Rn, rel	Decrement Register and jump if not zero	2	2/3
DJNZ direct, rel	Decrement direct byte and jump if not zero	3	3/4
NOP	No operation	1	1

**Notes on Registers, Operands and Addressing Modes:**

**Rn** - Register R0-R7 of the currently selected register bank.

**@Ri** - Data RAM location addressed indirectly through R0 or R1.

**rel** - 8-bit, signed (two's complement) offset relative to the first byte of the following instruction. Used by SJMP and all conditional jumps.

**direct** - 8-bit internal data location's address. This could be a direct-access Data RAM location (0x00-0x7F) or an SFR (0x80-0xFF).

**#data** - 8-bit constant

**#data16** - 16-bit constant

**bit** - Direct-accessed bit in Data RAM or SFR

**addr11** - 11-bit destination address used by ACALL and AJMP. The destination must be within the same 2K-byte page of program memory as the first byte of the following instruction.

**addr16** - 16-bit destination address used by LCALL and LJMP. The destination may be anywhere within the 8K-byte program memory space.

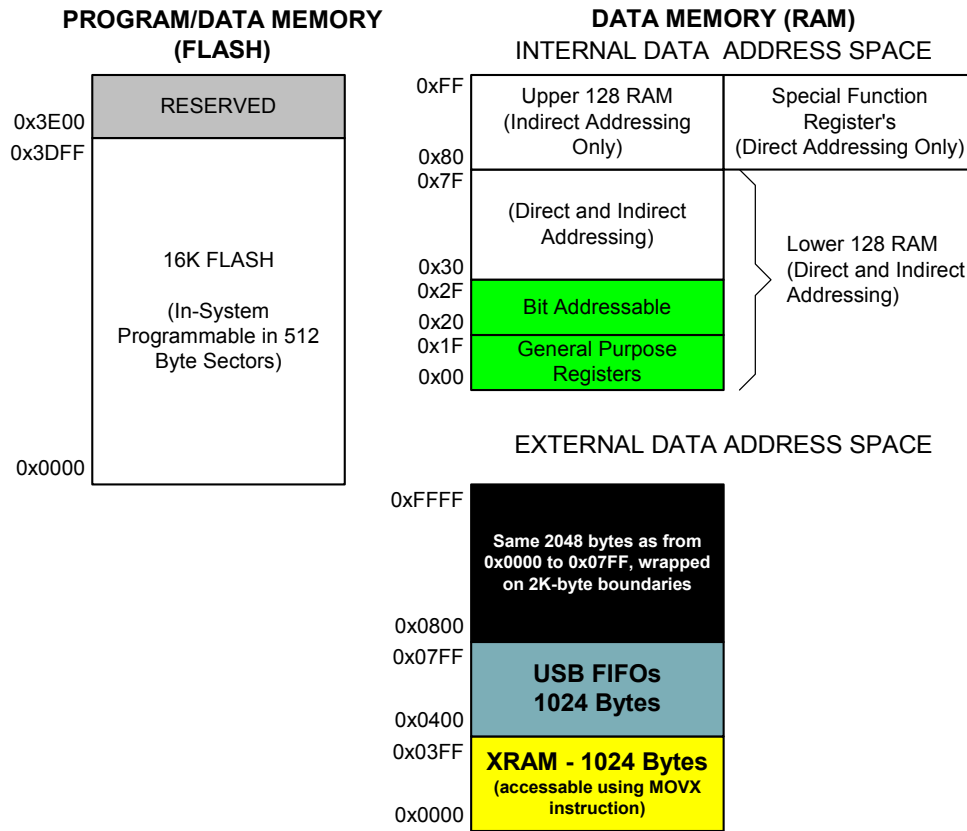
There is one unused opcode (0xA5) that performs the same function as NOP.

All mnemonics copyrighted © Intel Corporation 1980.

## 9.2. Memory Organization

The memory organization of the CIP-51 System Controller is similar to that of a standard 8051. There are two separate memory spaces: program memory and data memory. Program and data memory share the same address space but are accessed via different instruction types. The CIP-51 memory organization is shown in Figure 9.2.

**Figure 9.2. Memory Map**



### 9.2.1. Program Memory

The CIP-51 core has a 64k-byte program memory space. The C8051F320/1 implements 16k bytes of this program memory space as in-system, re-programmable FLASH memory, organized in a contiguous block from addresses 0x0000 to 0x3FFF. Addresses above 0x3DFF are reserved.

Program memory is normally assumed to be read-only. However, the CIP-51 can write to program memory by setting the Program Store Write Enable bit (PSCTL.0) and using the MOVX instruction. This feature provides a mechanism for the CIP-51 to update program code and use the program memory space for non-volatile data storage. Refer to **Section “11. FLASH Memory” on page 107** for further details.

## 9.2.2. Data Memory

The CIP-51 includes 256 of internal RAM mapped into the data memory space from 0x00 through 0xFF. The lower 128 bytes of data memory are used for general purpose registers and scratch pad memory. Either direct or indirect addressing may be used to access the lower 128 bytes of data memory. Locations 0x00 through 0x1F are addressable as four banks of general purpose registers, each bank consisting of eight byte-wide registers. The next 16 bytes, locations 0x20 through 0x2F, may either be addressed as bytes or as 128 bit locations accessible with the direct addressing mode.

The upper 128 bytes of data memory are accessible only by indirect addressing. This region occupies the same address space as the Special Function Registers (SFR) but is physically separate from the SFR space. The addressing mode used by an instruction when accessing locations above 0x7F determines whether the CPU accesses the upper 128 bytes of data memory space or the SFRs. Instructions that use direct addressing will access the SFR space. Instructions using indirect addressing above 0x7F access the upper 128 bytes of data memory. Figure 9.2 illustrates the data memory organization of the CIP-51.

## 9.2.3. General Purpose Registers

The lower 32 bytes of data memory, locations 0x00 through 0x1F, may be addressed as four banks of general-purpose registers. Each bank consists of eight byte-wide registers designated R0 through R7. Only one of these banks may be enabled at a time. Two bits in the program status word, RS0 (PSW.3) and RS1 (PSW.4), select the active register bank (see description of the PSW in Figure 9.6). This allows fast context switching when entering subroutines and interrupt service routines. Indirect addressing modes use registers R0 and R1 as index registers.

## 9.2.4. Bit Addressable Locations

In addition to direct access to data memory organized as bytes, the sixteen data memory locations at 0x20 through 0x2F are also accessible as 128 individually addressable bits. Each bit has a bit address from 0x00 to 0x7F. Bit 0 of the byte at 0x20 has bit address 0x00 while bit7 of the byte at 0x20 has bit address 0x07. Bit 7 of the byte at 0x2F has bit address 0x7F. A bit access is distinguished from a full byte access by the type of instruction used (bit source or destination operands as opposed to a byte source or destination).

The MCS-51™ assembly language allows an alternate notation for bit addressing of the form XX.B where XX is the byte address and B is the bit position within the byte. For example, the instruction:

```
MOV    C, 22h.3
```

moves the Boolean value at 0x13 (bit 3 of the byte at location 0x22) into the Carry flag.

## 9.2.5. Stack

A programmer's stack can be located anywhere in the 256-byte data memory. The stack area is designated using the Stack Pointer (SP, 0x81) SFR. The SP will point to the last location used. The next value pushed on the stack is placed at SP+1 and then SP is incremented. A reset initializes the stack pointer to location 0x07. Therefore, the first value pushed on the stack is placed at location 0x08, which is also the first register (R0) of register bank 1. Thus, if more than one register bank is to be used, the SP should be initialized to a location in the data memory not being used for data storage. The stack depth can extend up to 256 bytes.



## 9.2.6. Special Function Registers

The direct-access data memory locations from 0x80 to 0xFF constitute the special function registers (SFRs). The SFRs provide control and data exchange with the CIP-51's resources and peripherals. The CIP-51 duplicates the SFRs found in a typical 8051 implementation as well as implementing additional SFRs used to configure and access the sub-systems unique to the MCU. This allows the addition of new functionality while retaining compatibility with the MCS-51™ instruction set. Table 9.2 lists the SFRs implemented in the CIP-51 System Controller.

The SFR registers are accessed anytime the direct addressing mode is used to access memory locations from 0x80 to 0xFF. SFRs with addresses ending in 0x0 or 0x8 (e.g. P0, TCON, SCON0, IE, etc.) are bit-addressable as well as byte-addressable. All other SFRs are byte-addressable only. Unoccupied addresses in the SFR space are reserved for future use. Accessing these areas will have an indeterminate effect and should be avoided. Refer to the corresponding pages of the datasheet, as indicated in Table 9.3, for a detailed description of each register.

**Table 9.2. Special Function Register (SFR) Memory Map**

F8	SPI0CN	PCA0L	PCA0H	PCA0CPL0	PCA0CPH0	PCA0CPL4	PCA0CPH4	VDM0CN
F0	B	P0MDIN	P1MDIN	P2MDIN	P3MDIN		EIP1	EIP2
E8	ADC0CN	PCA0CPL1	PCA0CPH1	PCA0CPL2	PCA0CPH2	PCA0CPL3	PCA0CPH3	RSTSRC
E0	ACC	XBR0	XBR1		IT01CF		EIE1	EIE2
D8	PCA0CN	PCA0MD	PCA0CPM0	PCA0CPM1	PCA0CPM2	PCA0CPM3	PCA0CPM4	
D0	PSW	REF0CN			P0SKIP	P1SKIP	P2SKIP	USB0XCN
C8	TMR2CN	REG0CN	TMR2RLL	TMR2RLH	TMR2L	TMR2H		
C0	SMB0CN	SMB0CF	SMB0DAT	ADC0GTL	ADC0GTH	ADC0LTL	ADC0LTH	
B8	IP	CLKMUL	AMX0N	AMX0P	ADC0CF	ADC0L	ADC0H	
B0	P3	OSCXCN	OSCICN	OSCICL			FLSCL	FLKEY
A8	IE	CLKSEL	EMI0CN					
A0	P2	SPI0CFG	SPI0CKR	SPI0DAT	P0MDOUT	P1MDOUT	P2MDOUT	P3MDOUT
98	SCON0	SBUF0	CPT1CN	CPT0CN	CPT1MD	CPT0MD	CPT1MX	CPT0MX
90	P1	TMR3CN	TMR3RLL	TMR3RLH	TMR3L	TMR3H	USB0ADR	USB0DAT
88	TCON	TMOD	TL0	TL1	TH0	TH1	CKCON	PSCTL
80	P0	SP	DPL	DPH				PCON
	0(8) (bit addressable)	1(9)	2(A)	3(B)	4(C)	5(D)	6(E)	7(F)

**Table 9.3. Special Function Registers**

SFRs are listed in alphabetical order. All undefined SFR locations are reserved

Register	Address	Description	Page
ACC	0xE0	Accumulator	86
ADC0CF	0xBC	ADC0 Configuration	47
ADC0CN	0xE8	ADC0 Control	49
ADC0GTH	0xC4	ADC0 Greater-Than Compare High	50
ADC0GTL	0xC3	ADC0 Greater-Than Compare Low	50
ADC0H	0xBE	ADC0 High	47
ADC0L	0xBD	ADC0 Low	48
ADC0LTH	0xC6	ADC0 Less-Than Compare Word High	51

## Table 9.3. Special Function Registers

Register	Address	Description	Page No.
ADC0LTL	0xC5	ADC0 Less-Than Compare Word Low	51
AMX0N	0xBA	AMUX0 Negative Channel Select	46
AMX0P	0xBB	AMUX0 Positive Channel Select	45
B	0xF0	B Register	86
CKCON	0x8E	Clock Control	223
CLKSEL	0xA9	Clock Select	125
CPT0CN	0x9B	Comparator0 Control	60
CPT0MD	0x9D	Comparator0 Mode Selection	62
CPT0MX	0x9F	Comparator0 MUX Selection	61
CPT1CN	0x9A	Comparator1 Control	63
CPT1MD	0x9C	Comparator1 Mode Selection	65
CPT1MX	0x9E	Comparator1 MUX Selection	64
DPH	0x83	Data Pointer High	84
DPL	0x82	Data Pointer Low	84
EIE1	0xE6	Extended Interrupt Enable 1	92
EIE2	0xE7	Extended Interrupt Enable 2	94
EIP1	0xF6	Extended Interrupt Priority 1	93
EIP2	0xF7	Extended Interrupt Priority 2	94
EMIOCN	0xAA	External Memory Interface Control	115
FLKEY	0xB7	FLASH Lock and Key	111
FLSCL	0xB6	FLASH Scale	111
IE	0xA8	Interrupt Enable	90
IP	0xB8	Interrupt Priority	91
IT01CF	0xE4	INT0/INT1 Configuration	95
OSCICL	0xB3	Internal Oscillator Calibration	119
OSICN	0xB2	Internal Oscillator Control	119
OSCXCN	0xB1	External Oscillator Control	122
P0	0x80	Port 0 Latch	135
P0MDIN	0xF1	Port 0 Input Mode Configuration	135
P0MDOUT	0xA4	Port 0 Output Mode Configuration	136
P0SKIP	0xD4	Port 0 Skip	136
P1	0x90	Port 1 Latch	137
P1MDIN	0xF2	Port 1 Input Mode Configuration	137
P1MDOUT	0xA5	Port 1 Output Mode Configuration	138
P1SKIP	0xD5	Port 1 Skip	138
P2	0xA0	Port 2 Latch	139
P2MDIN	0xF3	Port 2 Input Mode Configuration	139
P2MDOUT	0xA6	Port 2 Output Mode Configuration	140
P2SKIP	0xD6	Port 2 Skip	140
P3	0xB0	Port 3 Latch	141
P3MDIN	0xF4	Port 3 Input Mode Configuration	141
P3MDOUT	0xA7	Port 3 Output Mode Configuration	142
PCA0CN	0xD8	PCA Control	248
PCA0CPH0	0xFC	PCA Capture 0 High	252
PCA0CPH1	0xEA	PCA Capture 1 High	252
PCA0CPH2	0xEC	PCA Capture 2 High	252

Table 9.3. Special Function Registers

Register	Address	Description	Page No.
PCA0CPH3	0xEE	PCA Capture 3High	252
PCA0CPH4	0xFE	PCA Capture 4 High	252
PCA0CPL0	0xFB	PCA Capture 0 Low	252
PCA0CPL1	0xE9	PCA Capture 1 Low	252
PCA0CPL2	0xEB	PCA Capture 2 Low	252
PCA0CPL3	0xED	PCA Capture 3Low	252
PCA0CPL4	0xFD	PCA Capture 4 Low	252
PCA0CPM0	0xDA	PCA Module 0 Mode Register	250
PCA0CPM1	0xDB	PCA Module 1 Mode Register	250
PCA0CPM2	0xDC	PCA Module 2 Mode Register	250
PCA0CPM3	0xDD	PCA Module 3 Mode Register	250
PCA0CPM4	0xDE	PCA Module 4 Mode Register	250
PCA0H	0xFA	PCA Counter High	251
PCA0L	0xF9	PCA Counter Low	251
PCA0MD	0xD9	PCA Mode	249
PCON	0x87	Power Control	97
PSCTL	0x8F	Program Store R/W Control	110
PSW	0xD0	Program Status Word	85
REF0CN	0xD1	Voltage Reference Control	56
RSTSRC	0xEF	Reset Source Configuration/Status	104
SBUF0	0x99	UART0 Data Buffer	199
SCON0	0x98	UART0 Control	198
SMB0CF	0xC1	SMBus Configuration	182
SMB0CN	0xC0	SMBus Control	184
SMB0DAT	0xC2	SMBus Data	186
SP	0x81	Stack Pointer	85
SPI0CFG	0xA1	SPI Configuration	210
SPI0CKR	0xA2	SPI Clock Rate Control	212
SPI0CN	0xF8	SPI Control	211
SPI0DAT	0xA3	SPI Data	213
TCON	0x88	Timer/Counter Control	221
TH0	0x8C	Timer/Counter 0 High	224
TH1	0x8D	Timer/Counter 1 High	224
TL0	0x8A	Timer/Counter 0 Low	224
TL1	0x8B	Timer/Counter 1 Low	224
TMOD	0x89	Timer/Counter Mode	222
TMR2CN	0xC8	Timer/Counter 2 Control	228
TMR2H	0xCD	Timer/Counter 2 High	229
TMR2L	0xCC	Timer/Counter 2 Low	229
TMR2RLH	0xCB	Timer/Counter 2 Reload High	229
TMR2RLL	0xCA	Timer/Counter 2 Reload Low	229
TMR3CN	0x91	Timer/Counter 3Control	233
TMR3H	0x95	Timer/Counter 3 High	234
TMR3L	0x94	Timer/Counter 3Low	234
TMR3RLH	0x93	Timer/Counter 3 Reload High	234
TMR3RLL	0x92	Timer/Counter 3 Reload Low	234

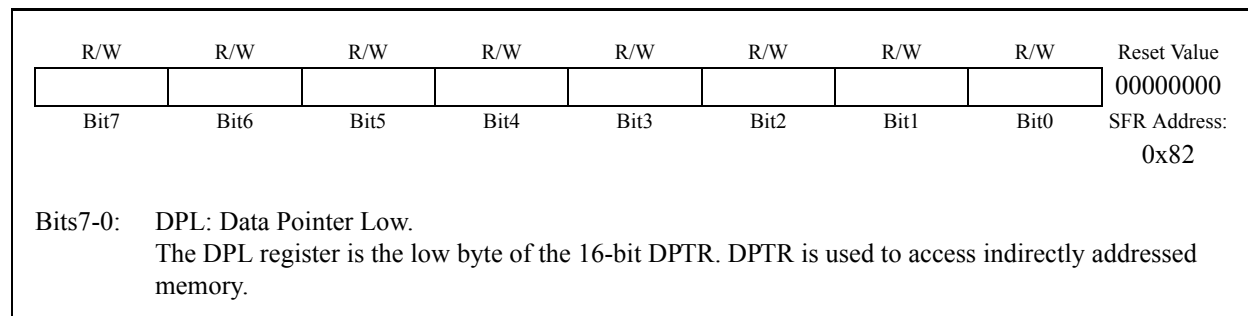
**Table 9.3. Special Function Registers**

Register	Address	Description	Page No.
VDM0CN	0xFF	VDD Monitor Control	101
XBR0	0xE1	Port I/O Crossbar Control 0	132
XBR1	0xE2	Port I/O Crossbar Control 1	133
0x84-0x86, 0xAB-0xAF, 0xB4, 0xB5, 0xBF, 0xC7, 0xCE, 0xCF, 0xD2, 0xD3, 0xDF, 0xE3, 0xE5, 0xF5		Reserved	

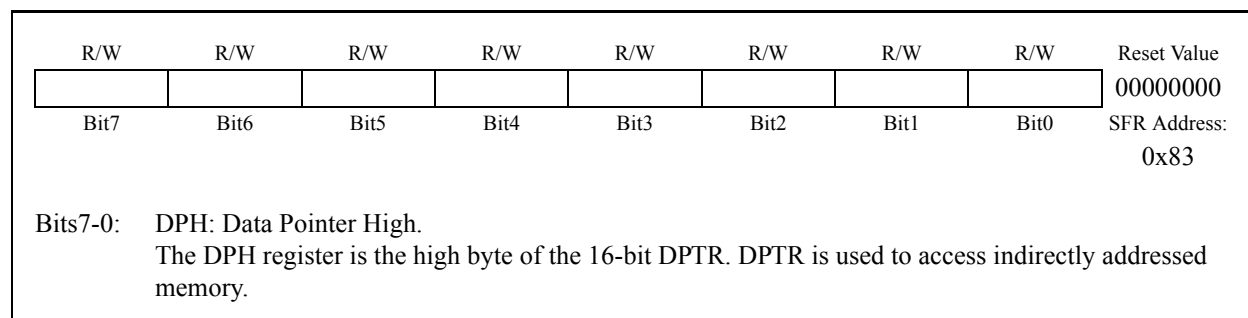
### 9.2.7. Register Descriptions

Following are descriptions of SFRs related to the operation of the CIP-51 System Controller. Reserved bits should not be set to logic 1. Future product versions may use these bits to implement new features in which case the reset value of the bit will be logic 0, selecting the feature's default state. Detailed descriptions of the remaining SFRs are included in the sections of the datasheet associated with their corresponding system function.

**Figure 9.3. DPL: Data Pointer Low Byte**



**Figure 9.4. DPH: Data Pointer High Byte**



**Figure 9.5. SP: Stack Pointer**

R/W	R/W	R/W	R/W	R/W	R/W	R/W	R/W	Reset Value
								00000111
Bit7	Bit6	Bit5	Bit4	Bit3	Bit2	Bit1	Bit0	SFR Address: 0x81

Bits7-0: SP: Stack Pointer.  
The Stack Pointer holds the location of the top of the stack. The stack pointer is incremented before every PUSH operation. The SP register defaults to 0x07 after reset.

**Figure 9.6. PSW: Program Status Word**

R/W	R/W	R/W	R/W	R/W	R/W	R/W	R	Reset Value
CY	AC	F0	RS1	RS0	OV	F1	PARITY	00000000
Bit7	Bit6	Bit5	Bit4	Bit3	Bit2	Bit1	Bit0	SFR Address: (bit addressable) 0xD0

Bit7: CY: Carry Flag.  
This bit is set when the last arithmetic operation resulted in a carry (addition) or a borrow (subtraction). It is cleared to logic 0 by all other arithmetic operations.

Bit6: AC: Auxiliary Carry Flag  
This bit is set when the last arithmetic operation resulted in a carry into (addition) or a borrow from (subtraction) the high order nibble. It is cleared to logic 0 by all other arithmetic operations.

Bit5: F0: User Flag 0.  
This is a bit-addressable, general purpose flag for use under software control.

Bits4-3: RS1-RS0: Register Bank Select.  
These bits select which register bank is used during register accesses.

RS1	RS0	Register Bank	Address
0	0	0	0x00 - 0x07
0	1	1	0x08 - 0x0F
1	0	2	0x10 - 0x17
1	1	3	0x18 - 0x1F

Bit2: OV: Overflow Flag.  
This bit is set to 1 under the following circumstances:

- An ADD, ADDC, or SUBB instruction causes a sign-change overflow.
- A MUL instruction results in an overflow (result is greater than 255).
- A DIV instruction causes a divide-by-zero condition.

The OV bit is cleared to 0 by the ADD, ADDC, SUBB, MUL, and DIV instructions in all other cases.

Bit1: F1: User Flag 1.  
This is a bit-addressable, general purpose flag for use under software control.

Bit0: PARITY: Parity Flag.  
This bit is set to logic 1 if the sum of the eight bits in the accumulator is odd and cleared if the sum is even.

**Figure 9.7. ACC: Accumulator**

R/W	R/W	R/W	R/W	R/W	R/W	R/W	R/W	Reset Value
ACC.7	ACC.6	ACC.5	ACC.4	ACC.3	ACC.2	ACC.1	ACC.0	00000000
Bit7	Bit6	Bit5	Bit4	Bit3	Bit2	Bit1	Bit0	SFR Address: (bit addressable) 0xE0

Bits7-0: ACC: Accumulator.  
This register is the accumulator for arithmetic operations.

**Figure 9.8. B: B Register**

R/W	R/W	R/W	R/W	R/W	R/W	R/W	R/W	Reset Value
B.7	B.6	B.5	B.4	B.3	B.2	B.1	B.0	00000000
Bit7	Bit6	Bit5	Bit4	Bit3	Bit2	Bit1	Bit0	SFR Address: (bit addressable) 0xF0

Bits7-0: B: B Register.  
This register serves as a second accumulator for certain arithmetic operations.

---

## 9.3. Interrupt Handler

The CIP-51 includes an extended interrupt system supporting a total of 16 interrupt sources with two priority levels. The allocation of interrupt sources between on-chip peripherals and external inputs pins varies according to the specific version of the device. Each interrupt source has one or more associated interrupt-pending flag(s) located in an SFR. When a peripheral or external source meets a valid interrupt condition, the associated interrupt-pending flag is set to logic 1.

If interrupts are enabled for the source, an interrupt request is generated when the interrupt-pending flag is set. As soon as execution of the current instruction is complete, the CPU generates an LCALL to a predetermined address to begin execution of an interrupt service routine (ISR). Each ISR must end with an RETI instruction, which returns program execution to the next instruction that would have been executed if the interrupt request had not occurred. If interrupts are not enabled, the interrupt-pending flag is ignored by the hardware and program execution continues as normal. (The interrupt-pending flag is set to logic 1 regardless of the interrupt's enable/disable state.)

Each interrupt source can be individually enabled or disabled through the use of an associated interrupt enable bit in an SFR (IE-EIE2). However, interrupts must first be globally enabled by setting the EA bit (IE.7) to logic 1 before the individual interrupt enables are recognized. Setting the EA bit to logic 0 disables all interrupt sources regardless of the individual interrupt-enable settings.

Some interrupt-pending flags are automatically cleared by the hardware when the CPU vectors to the ISR. However, most are not cleared by the hardware and must be cleared by software before returning from the ISR. If an interrupt-pending flag remains set after the CPU completes the return-from-interrupt (RETI) instruction, a new interrupt request will be generated immediately and the CPU will re-enter the ISR after the completion of the next instruction.

### 9.3.1. MCU Interrupt Sources and Vectors

The MCU supports 16 interrupt sources. Software can simulate an interrupt by setting any interrupt-pending flag to logic 1. If interrupts are enabled for the flag, an interrupt request will be generated and the CPU will vector to the ISR address associated with the interrupt-pending flag. MCU interrupt sources, associated vector addresses, priority order and control bits are summarized in Table 9.4 on page 89. Refer to the datasheet section associated with a particular on-chip peripheral for information regarding valid interrupt conditions for the peripheral and the behavior of its interrupt-pending flag(s).

## 9.3.2. External Interrupts

The /INT0 and /INT1 external interrupt sources are configurable as active high or low, edge or level sensitive. The IN0PL (/INT0 Polarity) and IN1PL (/INT1 Polarity) bits in the IT01CF register select active high or active low; the IT0 and IT1 bits in TCON (Section “19.1. Timer 0 and Timer 1” on page 217) select level or edge sensitive. The table below lists the possible configurations.

IT0	IN0PL	/INT0 Interrupt
1	0	Active low, edge sensitive
1	1	Active high, edge sensitive
0	0	Active low, level sensitive
0	1	Active high, level sensitive

IT1	IN1PL	/INT1 Interrupt
1	0	Active low, edge sensitive
1	1	Active high, edge sensitive
0	0	Active low, level sensitive
0	1	Active high, level sensitive

/INT0 and /INT1 are assigned to Port pins as defined in the IT01CF register (see Figure 9.15). Note that /INT0 and /INT0 Port pin assignments are independent of any Crossbar assignments. /INT0 and /INT1 will monitor their assigned Port pins without disturbing the peripheral that was assigned the Port pin via the Crossbar. To assign a Port pin only to /INT0 and/or /INT1, configure the Crossbar to skip the selected pin(s). This is accomplished by setting the associated bit in register XBR0 (see Section “14.1. Priority Crossbar Decoder” on page 129 for complete details on configuring the Crossbar).

IE0 (TCON.1) and IE1 (TCON.3) serve as the interrupt-pending flags for the /INT0 and /INT1 external interrupts, respectively. If an /INT0 or /INT1 external interrupt is configured as edge-sensitive, the corresponding interrupt-pending flag is automatically cleared by the hardware when the CPU vectors to the ISR. When configured as level sensitive, the interrupt-pending flag remains logic 1 while the input is active as defined by the corresponding polarity bit (IN0PL or IN1PL); the flag remains logic 0 while the input is inactive. The external interrupt source must hold the input active until the interrupt request is recognized. It must then deactivate the interrupt request before execution of the ISR completes or another interrupt request will be generated.

## 9.3.3. Interrupt Priorities

Each interrupt source can be individually programmed to one of two priority levels: low or high. A low priority interrupt service routine can be preempted by a high priority interrupt. A high priority interrupt cannot be preempted. Each interrupt has an associated interrupt priority bit in an SFR (IP or EIP2) used to configure its priority level. Low priority is the default. If two interrupts are recognized simultaneously, the interrupt with the higher priority is serviced first. If both interrupts have the same priority level, a fixed priority order is used to arbitrate, given in Table 9.4.

## 9.3.4. Interrupt Latency

Interrupt response time depends on the state of the CPU when the interrupt occurs. Pending interrupts are sampled and priority decoded each system clock cycle. Therefore, the fastest possible response time is 5 system clock cycles: 1 clock cycle to detect the interrupt and 4 clock cycles to complete the LCALL to the ISR. If an interrupt is pending when a RETI is executed, a single instruction is executed before an LCALL is made to service the pending interrupt. Therefore, the maximum response time for an interrupt (when no other interrupt is currently being serviced or the new interrupt is of greater priority) occurs when the CPU is performing an RETI instruction followed by a DIV as the next instruction. In this case, the response time is 18 system clock cycles: 1 clock cycle to detect the interrupt, 5 clock cycles to execute the RETI, 8 clock cycles to complete the DIV instruction and 4 clock cycles to execute the LCALL to the ISR. If the CPU is executing an ISR for an interrupt with equal or higher priority, the new interrupt will not be serviced until the current ISR completes, including the RETI and following instruction.

Note that the CPU is stalled during FLASH write/erase operations and USB FIFO MOVX accesses (see Section “12.2. Accessing USB FIFO Space” on page 114). Interrupt service latency will be increased for interrupts occurring while the CPU is stalled. The latency for these situations will be determined by the standard interrupt service procedure (as described above) and the amount of time the CPU is stalled.



**Table 9.4. Interrupt Summary**

Interrupt Source	Interrupt Vector	Priority Order	Pending Flag	Bit addressable?	Cleared by HW?	Enable Flag	Priority Control
Reset	0x0000	Top	None	N/A	N/A	Always Enabled	Always Highest
External Interrupt 0 (/INT0)	0x0003	0	IE0 (TCON.1)	Y	Y	EX0 (IE.0)	PX0 (IP.0)
Timer 0 Overflow	0x000B	1	TF0 (TCON.5)	Y	Y	ET0 (IE.1)	PT0 (IP.1)
External Interrupt 1 (/INT1)	0x0013	2	IE1 (TCON.3)	Y	Y	EX1 (IE.2)	PX1 (IP.2)
Timer 1 Overflow	0x001B	3	TF1 (TCON.7)	Y	Y	ET1 (IE.3)	PT1 (IP.3)
UART0	0x0023	4	RI0 (SCON0.0) TI0 (SCON0.1)	Y	N	ES0 (IE.4)	PS0 (IP.4)
Timer 2 Overflow	0x002B	5	TF2H (TMR2CN.7) TF2L (TMR2CN.6)	Y	N	ET2 (IE.5)	PT2 (IP.5)
SPI0	0x0033	6	SPIF (SPI0CN.7) WCOL (SPI0CN.6) MODF (SPI0CN.5) RXOVRN (SPI0CN.4)	Y	N	ESPI0 (IE.6)	PSPI0 (IP.6)
SMB0	0x003B	7	SI (SMB0CN.0)	Y	N	ESMB0 (EIE1.0)	PSMB0 (EIP1.0)
USB0	0x0043	8	Special	N	N	EUSB0 (EIE1.1)	PUSB0 (EIP1.1)
ADC0 Window Compare	0x004B	9	AD0WINT (ADC0CN.3)	Y	N	EWADC0 (EIE1.2)	PWADC0 (EIP1.2)
ADC0 Conversion Complete	0x0053	10	AD0INT (ADC0CN.5)	Y	N	EADC0 (EIE1.3)	PADC0 (EIP1.3)
Programmable Counter Array	0x005B	11	CF (PCA0CN.7) CCFn (PCA0CN.n)	Y	N	EPCA0 (EIE1.4)	PPCA0 (EIP1.4)
Comparator0	0x0063	12	CP0FIF (CPT0CN.4) CP0RIF (CPT0CN.5)	N	N	ECP0 (EIE1.5)	PCP0 (EIP1.5)
Comparator1	0x006B	13	CP1FIF (CPT1CN.4) CP1RIF (CPT1CN.5)	N	N	ECP1 (EIE1.6)	PCP1 (EIP1.6)
Timer 3 Overflow	0x0073	14	TF3H (TMR3CN.7) TF3L (TMR3CN.6)	N	N	ET3 (EIE1.7)	PT3 (EIP1.7)
VBUS Level	0x007B	15	N/A	N/A	N/A	EVBUS (EIE2.0)	PVBUS (EIP2.0)

## 9.3.5. Interrupt Register Descriptions

The SFRs used to enable the interrupt sources and set their priority level are described below. Refer to the datasheet section associated with a particular on-chip peripheral for information regarding valid interrupt conditions for the peripheral and the behavior of its interrupt-pending flag(s).

**Figure 9.9. IE: Interrupt Enable**

R/W	R/W	R/W	R/W	R/W	R/W	R/W	R/W	Reset Value
EA	ESPI0	ET2	ES0	ET1	EX1	ET0	EX0	00000000
Bit7	Bit6	Bit5	Bit4	Bit3	Bit2	Bit1	Bit0	SFR Address: (bit addressable) 0xA8
Bit7:	EA: Enable All Interrupts. This bit globally enables/disables all interrupts. It overrides the individual interrupt mask settings. 0: Disable all interrupt sources. 1: Enable each interrupt according to its individual mask setting.							
Bit6:	ESPI0: Enable Serial Peripheral Interface (SPI0) Interrupt. This bit sets the masking of the SPI0 interrupts. 0: Disable all SPI0 interrupts. 1: Enable interrupt requests generated by SPI0.							
Bit5:	ET2: Enable Timer 2 Interrupt. This bit sets the masking of the Timer 2 interrupt. 0: Disable Timer 2 interrupt. 1: Enable interrupt requests generated by the TF2L or TF2H flags.							
Bit4:	ES0: Enable UART0 Interrupt. This bit sets the masking of the UART0 interrupt. 0: Disable UART0 interrupt. 1: Enable UART0 interrupt.							
Bit3:	ET1: Enable Timer 1 Interrupt. This bit sets the masking of the Timer 1 interrupt. 0: Disable all Timer 1 interrupt. 1: Enable interrupt requests generated by the TF1 flag.							
Bit2:	EX1: Enable External Interrupt 1. This bit sets the masking of External Interrupt 1. 0: Disable external interrupt 1. 1: Enable interrupt requests generated by the /INT1 input.							
Bit1:	ET0: Enable Timer 0 Interrupt. This bit sets the masking of the Timer 0 interrupt. 0: Disable all Timer 0 interrupt. 1: Enable interrupt requests generated by the TF0 flag.							
Bit0:	EX0: Enable External Interrupt 0. This bit sets the masking of External Interrupt 0. 0: Disable external interrupt 0. 1: Enable interrupt requests generated by the /INT0 input.							

**Figure 9.10. IP: Interrupt Priority**

R/W	R/W	R/W	R/W	R/W	R/W	R/W	R/W	Reset Value
-	PSPI0	PT2	PS0	PT1	PX1	PT0	PX0	10000000
Bit7	Bit6	Bit5	Bit4	Bit3	Bit2	Bit1	Bit0	SFR Address: 0xB8 (bit addressable)

Bit7: UNUSED. Read = 1, Write = don't care.

Bit6: PSPI0: Serial Peripheral Interface (SPI0) Interrupt Priority Control.  
This bit sets the priority of the SPI0 interrupt.  
0: SPI0 interrupt set to low priority level.  
1: SPI0 interrupt set to high priority level.

Bit5: PT2: Timer 2 Interrupt Priority Control.  
This bit sets the priority of the Timer 2 interrupt.  
0: Timer 2 interrupt set to low priority level.  
1: Timer 2 interrupts set to high priority level.

Bit4: PS0: UART0 Interrupt Priority Control.  
This bit sets the priority of the UART0 interrupt.  
0: UART0 interrupt set to low priority level.  
1: UART0 interrupts set to high priority level.

Bit3: PT1: Timer 1 Interrupt Priority Control.  
This bit sets the priority of the Timer 1 interrupt.  
0: Timer 1 interrupt set to low priority level.  
1: Timer 1 interrupts set to high priority level.

Bit2: PX1: External Interrupt 1 Priority Control.  
This bit sets the priority of the External Interrupt 1 interrupt.  
0: External Interrupt 1 set to low priority level.  
1: External Interrupt 1 set to high priority level.

Bit1: PT0: Timer 0 Interrupt Priority Control.  
This bit sets the priority of the Timer 0 interrupt.  
0: Timer 0 interrupt set to low priority level.  
1: Timer 0 interrupt set to high priority level.

Bit0: PX0: External Interrupt 0 Priority Control.  
This bit sets the priority of the External Interrupt 0 interrupt.  
0: External Interrupt 0 set to low priority level.  
1: External Interrupt 0 set to high priority level.

**Figure 9.11. EIE1: Extended Interrupt Enable 1**

R/W	R/W	R/W	R/W	R/W	R/W	R/W	R/W	Reset Value
ET3	ECP1	ECP0	EPCA0	EADC0	EWADC0	EUSB0	ESMB0	00000000
Bit7	Bit6	Bit5	Bit4	Bit3	Bit2	Bit1	Bit0	SFR Address: 0xE6
Bit7:	ET3: Enable Timer 3 Interrupt. This bit sets the masking of the Timer 3 interrupt. 0: Disable Timer 3 interrupts. 1: Enable interrupt requests generated by the TF3L or TF3H flags.							
Bit6:	ECP1: Enable Comparator1 (CP1) Interrupt. This bit sets the masking of the CP1 interrupt. 0: Disable CP1 interrupts. 1: Enable interrupt requests generated by the CP1RIF or CP1FIF flags.							
Bit5:	ECP0: Enable Comparator0 (CP0) Interrupt. This bit sets the masking of the CP0 interrupt. 0: Disable CP0 interrupts. 1: Enable interrupt requests generated by the CP0RIF or CP0FIF flags.							
Bit4:	EPCA0: Enable Programmable Counter Array (PCA0) Interrupt. This bit sets the masking of the PCA0 interrupts. 0: Disable all PCA0 interrupts. 1: Enable interrupt requests generated by PCA0.							
Bit3:	EADC0: Enable ADC0 Conversion Complete Interrupt. This bit sets the masking of the ADC0 Conversion Complete interrupt. 0: Disable ADC0 Conversion Complete interrupt. 1: Enable interrupt requests generated by the AD0INT flag.							
Bit2:	EWADC0: Enable Window Comparison ADC0 Interrupt. This bit sets the masking of ADC0 Window Comparison interrupt. 0: Disable ADC0 Window Comparison interrupt. 1: Enable interrupt requests generated by ADC0 Window Compare flag (AD0WINT).							
Bit1:	EUSB0: Enable USB0 Interrupt. This bit sets the masking of the USB0 interrupt. 0: Disable all USB0 interrupts. 1: Enable interrupt requests generated by USB0.							
Bit0:	ESMB0: Enable SMBus (SMB0) Interrupt. This bit sets the masking of the SMB0 interrupt. 0: Disable all SMB0 interrupts. 1: Enable interrupt requests generated by SMB0.							

**Figure 9.12. EIP1: Extended Interrupt Priority 1**

R/W	R/W	R/W	R/W	R/W	R/W	R/W	R/W	Reset Value
PT3	PCP1	PCP0	PPCA0	PADC0	PWADC0	PUSB0	PSMB0	00000000
Bit7	Bit6	Bit5	Bit4	Bit3	Bit2	Bit1	Bit0	SFR Address: 0xF6
Bit7:	PT3: Timer 3 Interrupt Priority Control. This bit sets the priority of the Timer 3 interrupt. 0: Timer 3 interrupts set to low priority level. 1: Timer 3 interrupts set to high priority level.							
Bit6:	PCP1: Comparator1 (CP1) Interrupt Priority Control. This bit sets the priority of the CP1 interrupt. 0: CP1 interrupt set to low priority level. 1: CP1 interrupt set to high priority level.							
Bit5:	PCP0: Comparator0 (CP0) Interrupt Priority Control. This bit sets the priority of the CP0 interrupt. 0: CP0 interrupt set to low priority level. 1: CP0 interrupt set to high priority level.							
Bit4:	PPCA0: Programmable Counter Array (PCA0) Interrupt Priority Control. This bit sets the priority of the PCA0 interrupt. 0: PCA0 interrupt set to low priority level. 1: PCA0 interrupt set to high priority level.							
Bit3:	PADC0 ADC0 Conversion Complete Interrupt Priority Control. This bit sets the priority of the ADC0 Conversion Complete interrupt. 0: ADC0 Conversion Complete interrupt set to low priority level. 1: ADC0 Conversion Complete interrupt set to high priority level.							
Bit2:	PWADC0: ADC0 Window Comparator Interrupt Priority Control. This bit sets the priority of the ADC0 Window interrupt. 0: ADC0 Window interrupt set to low priority level. 1: ADC0 Window interrupt set to high priority level.							
Bit1:	PUSB0: USB0 Interrupt Priority Control. This bit sets the priority of the USB0 interrupt. 0: USB0 interrupt set to low priority level. 1: USB0 interrupt set to high priority level.							
Bit0:	PSMB0: SMBus (SMB0) Interrupt Priority Control. This bit sets the priority of the SMB0 interrupt. 0: SMB0 interrupt set to low priority level. 1: SMB0 interrupt set to high priority level.							

**Figure 9.13. EIE2: Extended Interrupt Enable 2**

R/W	R/W	R/W	R/W	R/W	R/W	R/W	R/W	Reset Value
-	-	-	-	-	-	-	EVBUS	00000000
Bit7	Bit6	Bit5	Bit4	Bit3	Bit2	Bit1	Bit0	SFR Address: 0xE7

Bits7-1: UNUSED. Read = 0000000b. Write = don't care.  
 Bit0: EVBUS: Enable VBUS Level Interrupt.  
 This bit sets the masking of the VBUS interrupt.  
 0: Disable all VBUS interrupts.  
 1: Enable interrupt requests generated by VBUS level sense.

**Figure 9.14. EIP2: Extended Interrupt Priority 2**

R/W	R/W	R/W	R/W	R/W	R/W	R/W	R/W	Reset Value
-	-	-	-	-	-	-	PVBUS	00000000
Bit7	Bit6	Bit5	Bit4	Bit3	Bit2	Bit1	Bit0	SFR Address: 0xF7

Bits7-1: UNUSED. Read = 0000000b. Write = don't care.  
 Bit0: PVBUS: VBUS Level Interrupt Priority Control.  
 This bit sets the priority of the VBUS interrupt.  
 0: VBUS interrupt set to low priority level.  
 1: VBUS interrupt set to high priority level.

**Figure 9.15. IT01CF: INT0/INT1 Configuration Register**

R/W	R/W	R/W	R/W	R/W	R/W	R/W	R/W	Reset Value
IN1PL	IN1SL2	IN1SL1	IN1SL0	IN0PL	IN0SL2	IN0SL1	IN0SL0	00000001
Bit7	Bit6	Bit5	Bit4	Bit3	Bit2	Bit1	Bit0	SFR Address: 0xE4

Note: Refer to Figure 19.4 for INT0/1 edge- or level-sensitive interrupt selection.

Bit7: IN1PL: /INT1 Polarity  
 0: /INT1 input is active low.  
 1: /INT1 input is active high.

Bits6-4: IN1SL2-0: /INT1 Port Pin Selection Bits  
 These bits select which Port pin is assigned to /INT1. Note that this pin assignment is independent of the Crossbar; /INT1 will monitor the assigned Port pin without disturbing the peripheral that has been assigned the Port pin via the Crossbar. The Crossbar will not assign the Port pin to a peripheral if it is configured to skip the selected pin (accomplished by setting to '1' the corresponding bit in register POSKIP).

IN1SL2-0	/INT1 Port Pin
000	P0.0
001	P0.1
010	P0.2
011	P0.3
100	P0.4
101	P0.5
110	P0.6
111	P0.7

Bit3: IN0PL: /INT0 Polarity  
 0: /INT0 interrupt is active low.  
 1: /INT0 interrupt is active high.

Bits2-0: IN0SL2-0: /INT0 Port Pin Selection Bits  
 These bits select which Port pin is assigned to /INT0. Note that this pin assignment is independent of the Crossbar. /INT0 will monitor the assigned Port pin without disturbing the peripheral that has been assigned the Port pin via the Crossbar. The Crossbar will not assign the Port pin to a peripheral if it is configured to skip the selected pin (accomplished by setting to '1' the corresponding bit in register POSKIP).

IN0SL2-0	/INT0 Port Pin
000	P0.0
001	P0.1
010	P0.2
011	P0.3
100	P0.4
101	P0.5
110	P0.6
111	P0.7

## 9.4. Power Management Modes

The CIP-51 core has two software programmable power management modes: Idle and Stop. Idle mode halts the CPU while leaving the peripherals and clocks active. In Stop mode, the CPU is halted, all interrupts, are inactive, and the internal oscillator is stopped (analog peripherals remain in their selected states; the external oscillator is not affected). Since clocks are running in Idle mode, power consumption is dependent upon the system clock frequency and the number of peripherals left in active mode before entering Idle. Stop mode consumes the least power. Figure 1.15 describes the Power Control Register (PCON) used to control the CIP-51's power management modes.

Although the CIP-51 has Idle and Stop modes built in (as with any standard 8051 architecture), power management of the entire MCU is better accomplished through system clock and individual peripheral management. Each analog peripheral can be disabled when not in use and placed in low power mode. Digital peripherals, such as timers or serial buses, draw little power when they are not in use. Turning off the oscillators lowers power consumption considerably; however a reset is required to restart the MCU.

The internal oscillator can be placed in Suspend mode (see [Section “13. Oscillators” on page 117](#)). In Suspend mode, the internal oscillator is stopped until a non-idle USB event is detected, or the VBUS input signal matches the polarity selected by the VBPOL bit in register REG0CN (Figure 8.5 on Page 72).

### 9.4.1. Idle Mode

Setting the Idle Mode Select bit (PCON.0) causes the CIP-51 to halt the CPU and enter Idle mode as soon as the instruction that sets the bit completes execution. All internal registers and memory maintain their original data. All analog and digital peripherals can remain active during Idle mode.

Idle mode is terminated when an enabled interrupt is asserted or a reset occurs. The assertion of an enabled interrupt will cause the Idle Mode Selection bit (PCON.0) to be cleared and the CPU to resume operation. The pending interrupt will be serviced and the next instruction to be executed after the return from interrupt (RETI) will be the instruction immediately following the one that set the Idle Mode Select bit. If Idle mode is terminated by an internal or external reset, the CIP-51 performs a normal reset sequence and begins program execution at address 0x0000.

If enabled, the Watchdog Timer (WDT) will eventually cause an internal watchdog reset and thereby terminate the Idle mode. This feature protects the system from an unintended permanent shutdown in the event of an inadvertent write to the PCON register. If this behavior is not desired, the WDT may be disabled by software prior to entering the Idle mode if the WDT was initially configured to allow this operation. This provides the opportunity for additional power savings, allowing the system to remain in the Idle mode indefinitely, waiting for an external stimulus to wake up the system. Refer to [Section “10.6. PCA Watchdog Timer Reset” on page 102](#) for more information on the use and configuration of the WDT.

### 9.4.2. Stop Mode

Setting the Stop Mode Select bit (PCON.1) causes the CIP-51 to enter Stop mode as soon as the instruction that sets the bit completes execution. In Stop mode the internal oscillator, CPU, and all digital peripherals are stopped; the state of the external oscillator circuit is not affected. Each analog peripheral (including the external oscillator circuit) may be shut down individually prior to entering Stop Mode. Stop mode can only be terminated by an internal or external reset. On reset, the CIP-51 performs the normal reset sequence and begins program execution at address 0x0000.

If enabled, the Missing Clock Detector will cause an internal reset and thereby terminate the Stop mode. The Missing Clock Detector should be disabled if the CPU is to be put to in STOP mode for longer than the MCD timeout of 100  $\mu$ sec.



**Figure 9.16. PCON: Power Control Register**

R/W	R/W	R/W	R/W	R/W	R/W	R/W	R/W	Reset Value
GF5	GF4	GF3	GF2	GF1	GF0	STOP	IDLE	00000000
Bit7	Bit6	Bit5	Bit4	Bit3	Bit2	Bit1	Bit0	SFR Address: 0x87

Bits7-2: GF5-GF0: General Purpose Flags 5-0.  
These are general purpose flags for use under software control.

Bit1: STOP: Stop Mode Select.  
Setting this bit will place the CIP-51 in Stop mode. This bit will always be read as 0.  
1: CPU goes into Stop mode (internal oscillator stopped).

Bit0: IDLE: Idle Mode Select.  
Setting this bit will place the CIP-51 in Idle mode. This bit will always be read as 0.  
1: CPU goes into Idle mode. (Shuts off clock to CPU, but clock to Timers, Interrupts, Serial Ports, and Analog Peripherals are still active.)

---

*Notes*

## 10. RESET SOURCES

Reset circuitry allows the controller to be easily placed in a predefined default condition. On entry to this reset state, the following occur:

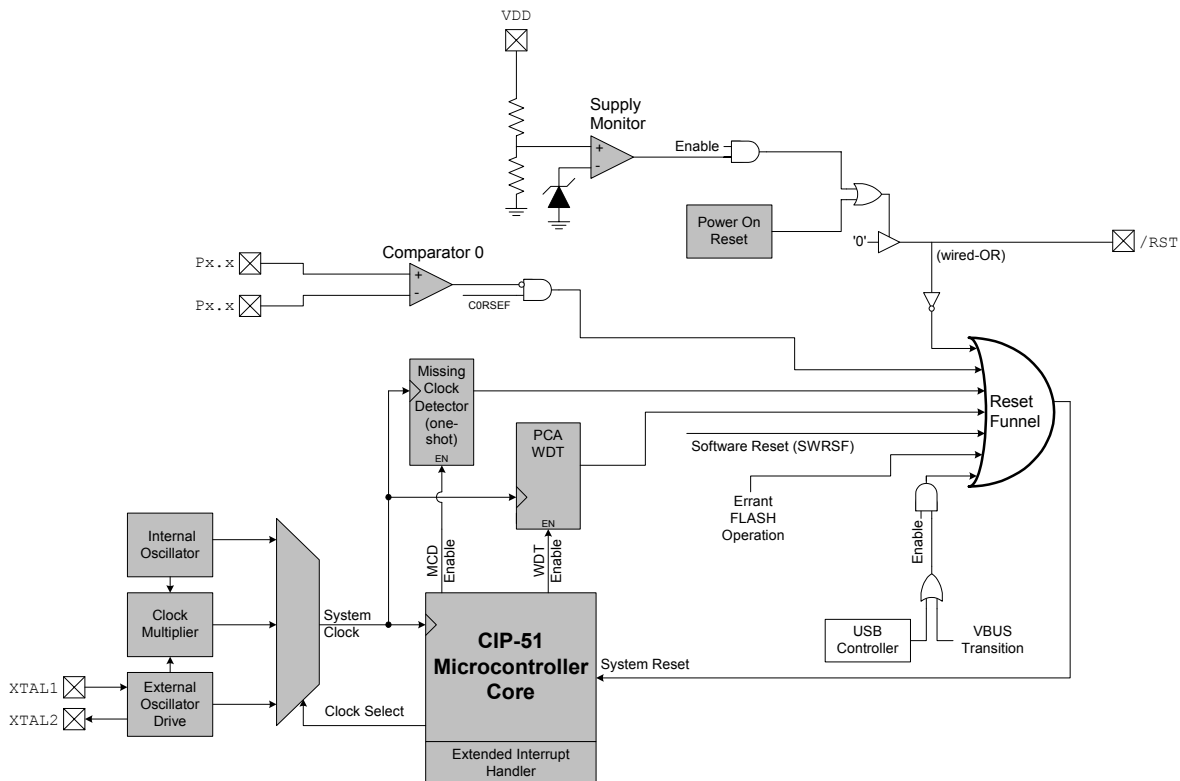
- CIP-51 halts program execution
- Special Function Registers (SFRs) are initialized to their defined reset values
- External Port pins are forced to a known state
- Interrupts and timers are disabled.

All SFRs are reset to the predefined values noted in the SFR detailed descriptions. The contents of internal data memory are unaffected during a reset; any previously stored data is preserved. However, since the stack pointer SFR is reset, the stack is effectively lost even though the data on the stack is not altered.

The Port I/O latches are reset to 0xFF (all logic ones) in open-drain mode. Weak pull-ups are enabled during and after the reset. For VDD Monitor and Power-On Resets, the /RST pin is driven low until the device exits the reset state.

On exit from the reset state, the program counter (PC) is reset, and the system clock defaults to the internal oscillator. Refer to **Section “13. Oscillators” on page 117** for information on selecting and configuring the system clock source. The Watchdog Timer is enabled with the system clock divided by 12 as its clock source (**Section “20.3. Watchdog Timer Mode” on page 246** details the use of the Watchdog Timer). Program execution begins at location 0x0000.

**Figure 10.1. Reset Sources**



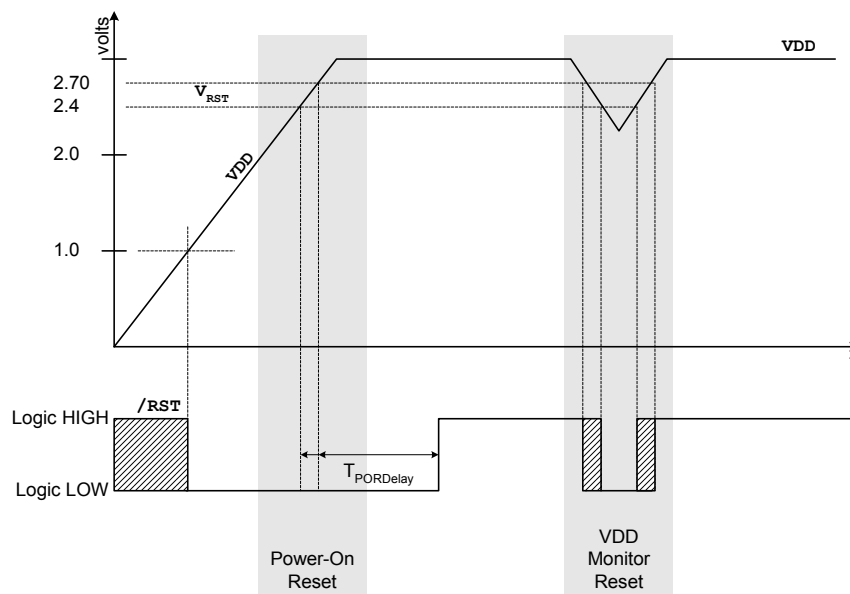
## 10.1. Power-On Reset

During power-up, the device is held in a reset state and the  $\overline{\text{RST}}$  pin is driven low until VDD settles above  $V_{\text{RST}}$ . A Power-On Reset delay ( $T_{\text{PORDelay}}$ ) occurs before the device is released from reset; this delay is typically less than 0.3 ms. Figure 10.2. plots the power-on and VDD monitor reset timing.

On exit from a power-on reset, the PORSF flag (RSTSRC.1) is set by hardware to logic 1. When PORSF is set, all of the other reset flags in the RSTSRC Register are indeterminate (PORSF is cleared by all other resets). Since all resets cause program execution to begin at the same location (0x0000) software can read the PORSF flag to determine if a power-up was the cause of reset. The content of internal data memory should be assumed to be undefined after a power-on reset. The VDD monitor is enabled following a power-on reset.

Software can force a power-on reset by writing '1' to the PINRSF bit in register RSTSRC.

**Figure 10.2. Power-On and VDD Monitor Reset Timing**



## 10.2. Power-Fail Reset / VDD Monitor

When a power-down transition or power irregularity causes VDD to drop below  $V_{RST}$ , the power supply monitor will drive the /RST pin low and hold the CIP-51 in a reset state (see Figure 10.2). When VDD returns to a level above  $V_{RST}$ , the CIP-51 will be released from the reset state. Note that even though internal data memory contents are not altered by the power-fail reset, it is impossible to determine if VDD dropped below the level required for data retention. If the PORSF flag reads ‘1’, the data may no longer be valid. The VDD monitor is enabled after power-on resets; however its defined state (enabled/disabled) is not altered by any other reset source. For example, if the VDD monitor is enabled and a software reset is performed, the VDD monitor will still be enabled after the reset.

**Important Note:** The VDD monitor must be enabled before it is selected as a reset source. Selecting the VDD monitor as a reset source before it is enabled and stabilized will cause a system reset. The procedure for configuring the VDD monitor as a reset source is shown below:

- Step 1. Enable the VDD monitor (VDM0CN.7 = ‘1’).
- Step 2. Wait for the VDD monitor to stabilize (see Table 10.1 for the VDD Monitor turn-on time).
- Step 3. Select the VDD monitor as a reset source (RSTSRC.1 = ‘1’).

See Figure 10.2 for VDD monitor timing. See Table 10.1 for complete electrical characteristics of the VDD monitor.

**Figure 10.3. VDM0CN: VDD Monitor Control**

R/W	R	R	R	R	R	R	R	Reset Value
VDMEN	VDDSTAT	Reserved	Reserved	Reserved	Reserved	Reserved	Reserved	Variable
Bit7	Bit6	Bit5	Bit4	Bit3	Bit2	Bit1	Bit0	SFR Address: 0xFF
Bit7:	VDMEN: VDD Monitor Enable. This bit turns the VDD monitor circuit on/off. The VDD Monitor cannot generate system resets until it is also selected as a reset source in register RSTSRC (Figure 10.4). The VDD Monitor must be allowed to stabilize before it is selected as a reset source. <b>Selecting the VDD monitor as a reset source before it has stabilized will generate a system reset.</b> See Table 10.1 for the minimum VDD Monitor turn-on time. The VDD Monitor is enabled following all POR resets. 0: VDD Monitor Disabled. 1: VDD Monitor Enabled.							
Bit6:	VDDSTAT: VDD Status. This bit indicates the current power supply status (VDD Monitor output). 0: VDD is at or below the VDD monitor threshold. 1: VDD is above the VDD monitor threshold.							
Bits5-0:	Reserved. Read = Variable. Write = don't care.							

## 10.3. External Reset

The external /RST pin provides a means for external circuitry to force the device into a reset state. Asserting an active-low signal on the /RST pin generates a reset; an external pull-up and/or decoupling of the /RST pin may be necessary to avoid erroneous noise-induced resets. See Table 10.1 for complete /RST pin specifications. The PINRSF flag (RSTSRC.0) is set on exit from an external reset.

## 10.4. Missing Clock Detector Reset

The Missing Clock Detector (MCD) is a one-shot circuit that is triggered by the system clock. If more than 100  $\mu$ s pass between rising edges on the system clock, the one-shot will time out and generate a reset. After a MCD reset, the MCDRSF flag (RSTSRC.2) will read '1', signifying the MCD as the reset source; otherwise, this bit reads '0'. Writing a '1' to the MCDRSF bit enables the Missing Clock Detector; writing a '0' disables it. The state of the /RST pin is unaffected by this reset.

## 10.5. Comparator0 Reset

Comparator0 can be configured as a reset source by writing a '1' to the CORSEF flag (RSTSRC.5). Comparator0 should be enabled and allowed to settle prior to writing to CORSEF to prevent any turn-on chatter on the output from generating an unwanted reset. The Comparator0 reset is active-low: if the non-inverting input voltage (on CP0+) is less than the inverting input voltage (on CP0-), a system reset is generated. After a Comparator0 reset, the CORSEF flag (RSTSRC.5) will read '1' signifying Comparator0 as the reset source; otherwise, this bit reads '0'. The state of the /RST pin is unaffected by this reset.

## 10.6. PCA Watchdog Timer Reset

The programmable Watchdog Timer (WDT) function of the Programmable Counter Array (PCA) can be used to prevent software from running out of control during a system malfunction. The PCA WDT function can be enabled or disabled by software as described in **Section "20.3. Watchdog Timer Mode" on page 246**; the WDT is enabled and clocked by SYSCLK / 12 following any reset. If a system malfunction prevents user software from updating the WDT, a reset is generated and the WDTRSF bit (RSTSRC.5) is set to '1'. The state of the /RST pin is unaffected by this reset.

## 10.7. FLASH Error Reset

If a FLASH read/write/erase or program read targets an illegal address, a system reset is generated. This may occur due to any of the following:

- A FLASH write or erase is attempted above user code space. This occurs when PSWE is set to '1' and a MOVX write operation is attempted above address 0x3DFF.
- A FLASH read is attempted above user code space. This occurs when a MOVC operation is attempted above address 0x3DFF.
- A Program read is attempted above user code space. This occurs when user code attempts to branch to an address above 0x3DFF.
- A FLASH read, write or erase attempt is restricted due to a FLASH security setting (see **Section "11.3. Security Options" on page 109**).

The FERROR bit (RSTSRC.6) is set following a FLASH error reset. The state of the /RST pin is unaffected by this reset.

## 10.8. Software Reset

Software may force a reset by writing a '1' to the SWRSF bit (RSTSRC.4). The SWRSF bit will read '1' following a software forced reset. The state of the /RST pin is unaffected by this reset.

## 10.9. USB Reset

Writing '1' to the USBRSF bit in register RSTSRC selects USB0 as a reset source. With USB0 selected as a reset source, a system reset will be generated when either of the following occur:

1. RESET signaling is detected on the USB network. The USB Function Controller (USB0) must be enabled for RESET signaling to be detected. See **Section "15. Universal Serial Bus Controller (USB0)" on page 143** for information on the USB Function Controller.
2. The voltage on the VBUS pin matches the polarity selected by the VBPOL bit in register REG0CN. See **Section "8. Voltage Regulator (REG0)" on page 67** for details on the VBUS detection circuit.

The USBRSF bit will read '1' following a USB reset. The state of the /RST pin is unaffected by this reset.

**Figure 10.4. RSTSRC: Reset Source Register**

R/W	R	R/W	R/W	R	R/W	R/W	R	Reset Value
USBRSF	FERROR	CORSEF	SWRSF	WDTRSF	MCDRSF	PORSF	PINRSF	Variable
Bit7	Bit6	Bit5	Bit4	Bit3	Bit2	Bit1	Bit0	SFR Address: 0xEF
Bit7:	USBRSF: USB Reset Flag 0: <b>Read:</b> Last reset was not a USB reset; <b>Write:</b> USB resets disabled. 1: <b>Read:</b> Last reset was a USB reset; <b>Write:</b> USB resets enabled.							
Bit6:	FERROR: FLASH Error Indicator. 0: Source of last reset was not a FLASH read/write/erase error. 1: Source of last reset was a FLASH read/write/erase error.							
Bit5:	CORSEF: Comparator0 Reset Enable and Flag. 0: <b>Read:</b> Source of last reset was not Comparator0; <b>Write:</b> Comparator0 is not a reset source. 1: <b>Read:</b> Source of last reset was Comparator0; <b>Write:</b> Comparator0 is a reset source (active-low).							
Bit4:	SWRSF: Software Reset Force and Flag. 0: <b>Read:</b> Source of last reset was not a write to the SWRSF bit; <b>Write:</b> No Effect. 1: <b>Read:</b> Source of last was a write to the SWRSF bit; <b>Write:</b> Forces a system reset.							
Bit3:	WDTRSF: Watchdog Timer Reset Flag. 0: Source of last reset was not a WDT timeout. 1: Source of last reset was a WDT timeout.							
Bit2:	MCDRSF: Missing Clock Detector Flag. 0: <b>Read:</b> Source of last reset was not a Missing Clock Detector timeout; <b>Write:</b> Missing Clock Detector disabled. 1: <b>Read:</b> Source of last reset was a Missing Clock Detector timeout; <b>Write:</b> Missing Clock Detector enabled; triggers a reset if a missing clock condition is detected.							
Bit1:	PORSF: Power-On / VDD Monitor Reset Flag. This bit is set anytime a power-on reset occurs. Writing this bit selects/deselects the VDD monitor as a reset source. <b>Note: writing '1' to this bit before the VDD monitor is enabled and stabilized can cause a system reset.</b> See register VDM0CN (Figure 10.3). 0: <b>Read:</b> Last reset was not a power-on or VDD monitor reset; <b>Write:</b> VDD monitor is not a reset source. 1: <b>Read:</b> Last reset was a power-on or VDD monitor reset; all other reset flags indeterminate; <b>Write:</b> VDD monitor is a reset source.							
Bit0:	PINRSF: HW Pin Reset Flag. 0: Source of last reset was not /RST pin. 1: Source of last reset was /RST pin.							
<p><b>Note: For bits that act as both reset source enables (on a write) and reset indicator flags (on a read), read-modify-write instructions read and modify the source enable only. This applies to bits: USBRSF, CORSEF, SWRSF, MCDRSF, PORSF.</b></p>								



**Table 10.1. Reset Electrical Characteristics**

-40°C to +85°C unless otherwise specified.

PARAMETER	CONDITIONS	MIN	TYP	MAX	UNITS
/RST Output Low Voltage	$I_{OL} = 8.5 \text{ mA}$ , $V_{DD} = 2.7 \text{ V}$ to $3.6 \text{ V}$			0.6	V
/RST Input High Voltage		$0.7 \times V_{DD}$			V
/RST Input Low Voltage				$0.3 \times V_{DD}$	
/RST Input Pull-Up Current	/RST = 0.0 V		25	40	$\mu\text{A}$
VDD POR Threshold ( $V_{RST}$ )		2.40	2.55	2.70	V
Missing Clock Detector Timeout	Time from last system clock rising edge to reset initiation	100	220	500	$\mu\text{s}$
Reset Time Delay	Delay between release of any reset source and code execution at location 0x0000	5.0			$\mu\text{s}$
Minimum /RST Low Time to Generate a System Reset		15			$\mu\text{s}$
VDD Monitor Turn-on Time		100			$\mu\text{s}$
VDD Monitor Supply Current			20	50	$\mu\text{A}$

*Notes*

---

## 11. FLASH MEMORY

On-chip, re-programmable FLASH memory is included for program code and non-volatile data storage. The FLASH memory can be programmed in-system, a single byte at a time, through the C2 interface or by software using the MOVX instruction. Once cleared to logic 0, a FLASH bit must be erased to set it back to logic 1. FLASH bytes would typically be erased (set to 0xFF) before being reprogrammed. The write and erase operations are automatically timed by hardware for proper execution; data polling to determine the end of the write/erase operation is not required. Code execution is stalled during a FLASH write/erase operation. Refer to Table 11.1 for complete FLASH memory electrical characteristics.

### 11.1. Programming The FLASH Memory

The simplest means of programming the FLASH memory is through the C2 interface using programming tools provided by Silicon Labs or a third party vendor. This is the only means for programming a non-initialized device. For details on the C2 commands to program FLASH memory, see **Section “21. C2 Interface” on page 253**.

**To ensure the integrity of FLASH contents, it is strongly recommended that the on-chip VDD Monitor be enabled in any system that includes code that writes and/or erases FLASH memory from software.**

#### 11.1.1. FLASH Lock and Key Functions

FLASH writes and erases by user software are protected with a lock and key function. The FLASH Lock and Key Register (FLKEY) must be written with the correct key codes, in sequence, before FLASH operations may be performed. The key codes are: 0xA5, 0xF1. The timing does not matter, but the codes must be written in order. If the key codes are written out of order, or the wrong codes are written, FLASH writes and erases will be disabled until the next system reset. FLASH writes and erases will also be disabled if a FLASH write or erase is attempted before the key codes have been written properly. The FLASH lock resets after each write or erase; the key codes must be written again before a following FLASH operation can be performed. The FLKEY register is detailed in Figure 11.3.

#### 11.1.2. FLASH Erase Procedure

The FLASH memory can be programmed by software using the MOVX write instruction with the address and data byte to be programmed provided as normal operands. Before writing to FLASH memory using MOVX, FLASH write operations must be enabled by: (1) Writing the FLASH key codes in sequence to the FLASH Lock register (FLKEY); and (2) Setting the PSWE Program Store Write Enable bit (PSCTL.0) to logic 1 (this directs the MOVX writes to target FLASH memory). The PSWE bit remains set until cleared by software.

A write to FLASH memory can clear bits to logic 0 but cannot set them; only an erase operation can set bits to logic 1 in FLASH. **A byte location to be programmed must be erased before a new value is written.** The FLASH memory is organized in 512-byte pages. The erase operation applies to an entire page (setting all bytes in the page to 0xFF). To erase an entire 512-byte page, perform the following steps:

- Step 1. Disable interrupts (recommended).
- Step 2. Write the first key code to FLKEY: 0xA5.
- Step 3. Write the second key code to FLKEY: 0xF1.
- Step 4. Set the PSEE bit (register PSCTL).
- Step 5. Set the PSWE bit (register PSCTL).
- Step 6. Using the MOVX instruction, write a data byte to any location within the 512-byte page to be erased.
- Step 7. Clear the PSWE bit (register PSCTL).
- Step 8. Clear the PSEE bit (register PSCTI).

# C8051F320/1

## 11.1.3. FLASH Write Procedure

FLASH bytes are programmed by software with the following sequence:

- Step 1. Disable interrupts (recommended).
- Step 2. Erase the 512-byte FLASH page containing the target location, as described in [Section 11.1.2](#).
- Step 3. Write the first key code to FLKEY: 0xA5.
- Step 4. Write the second key code to FLKEY: 0xF1.
- Step 5. Set the PSWE bit (register PSCTL).
- Step 6. Clear the PSEE bit (register PSCTL).
- Step 7. Using the MOVX instruction, write a single data byte to the desired location within the 512-byte sector.
- Step 8. Clear the PSWE bit (register PSCTL).

Steps 3-8 must be repeated for each byte to be written. After FLASH writes are complete, PSWE should be cleared so that MOVX instructions do not target program memory.

**Table 11.1. FLASH Electrical Characteristics**

PARAMETER	CONDITIONS	MIN	TYP	MAX	UNITS
FLASH Size	C8051F320/1	16384 <sup>†</sup>			bytes
Endurance		20k	100k		Erase/Write
Erase Cycle Time	25 MHz System Clock	10	15	20	ms
Write Cycle Time	25 MHz System Clock	40	55	70	μs

<sup>†</sup>Note: 512 bytes at location 0x3E00 to 0x3FFF are reserved.

## 11.2. Non-volatile Data Storage

The FLASH memory can be used for non-volatile data storage as well as program code. This allows data such as calibration coefficients to be calculated and stored at run time. Data is written using the MOVX write instruction and read using the MOVC instruction. Note: MOVX read instructions always target XRAM.

## 11.3. Security Options

The CIP-51 provides security options to protect the FLASH memory from inadvertent modification by software as well as to prevent the viewing of proprietary program code and constants. The Program Store Write Enable (bit PSWE in register PSCTL) and the Program Store Erase Enable (bit PSEE in register PSCTL) bits protect the FLASH memory from accidental modification by software. PSWE must be explicitly set to '1' before software can modify the FLASH memory; both PSWE and PSEE must be set to '1' before software can erase FLASH memory. Additional security features prevent proprietary program code and data constants from being read or altered across the C2 interface.

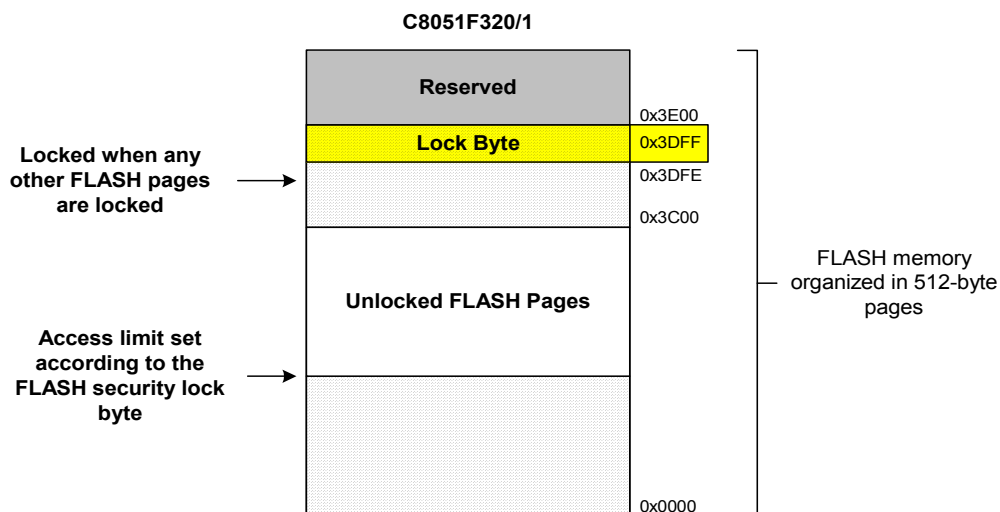
A Security Lock Byte located at the last byte of FLASH user space offers protection of the FLASH program memory from access (reads, writes, or erases) by unprotected code or the C2 interface. The FLASH security mechanism allows the user to lock  $n$  512-byte FLASH pages, starting at page 0 (addresses 0x0000 to 0x01FF), where  $n$  is the 1's compliment number represented by the Security Lock Byte. See example below.

Security Lock Byte:	11111101b
1's Compliment:	00000010b
FLASH pages locked:	2
Addresses locked:	0x0000 to 0x03FF

### Important Notes About the FLASH Security:

1. Clearing any bit of the Lock Byte to '0' will lock the FLASH page containing the Lock Byte (in addition to the selected pages).
2. Locked pages cannot be read, written, or erased via the C2 interface.
3. Locked pages cannot be read, written, or erased by user firmware executing from unlocked memory space.
4. User firmware executing in a locked page may read and write FLASH memory in any locked or unlocked page excluding the reserved area.
5. User firmware executing in a locked page may erase FLASH memory in any locked or unlocked page excluding the reserved area and the page containing the Lock Byte.
6. Locked pages can only be unlocked through the C2 interface with a C2 Device Erase command.
7. If a user firmware FLASH access attempt is denied (per restrictions #3, #4, and #5 above), a FLASH Error system reset will be generated.

**Figure 11.1. FLASH Program Memory Map and Security Byte**



**Figure 11.2. PSCTL: Program Store R/W Control**

R/W	R/W	R/W	R/W	R/W	R/W	R/W	R/W	Reset Value
-	-	-	-	-	Reserved	PSEE	PSWE	00000000
Bit7	Bit6	Bit5	Bit4	Bit3	Bit2	Bit1	Bit0	SFR Address: 0x8F

Bits7-3: Unused: Read = 00000b. Write = don't care.

Bit2: Reserved. Read = 0b. Must Write = 0b.

Bit1: PSEE: Program Store Erase Enable  
Setting this bit (in combination with PSWE) allows an entire page of FLASH program memory to be erased. If this bit is logic 1 and FLASH writes are enabled (PSWE is logic 1), a write to FLASH memory using the MOVX instruction will erase the entire page that contains the location addressed by the MOVX instruction. The value of the data byte written does not matter.  
0: FLASH program memory erasure disabled.  
1: FLASH program memory erasure enabled.

Bit0: PSWE: Program Store Write Enable  
Setting this bit allows writing a byte of data to the FLASH program memory using the MOVX write instruction. The FLASH location should be erased before writing data.  
0: Writes to FLASH program memory disabled.  
1: Writes to FLASH program memory enabled; the MOVX write instruction targets FLASH memory.

**Figure 11.3. FLKEY: FLASH Lock and Key Register**

R/W	R/W	R/W	R/W	R/W	R/W	R/W	R/W	Reset Value
								00000000
Bit7	Bit6	Bit5	Bit4	Bit3	Bit2	Bit1	Bit0	SFR Address: 0xB7

Bits7-0: FLKEY: FLASH Lock and Key Register

Write:  
This register must be written to before FLASH writes or erases can be performed. FLASH remains locked until this register is written to with the following key codes: 0xA5, 0xF1. The timing of the writes does not matter, as long as the codes are written in order. The key codes must be written for each FLASH write or erase operation. FLASH will be locked until the next system reset if the wrong codes are written or if a FLASH operation is attempted before the codes have been written correctly.

Read:  
When read, bits 1-0 indicate the current FLASH lock state.

00: FLASH is write/erase locked.  
01: The first key code has been written (0xA5).  
10: FLASH is unlocked (writes/erases allowed).  
11: FLASH writes/erases disabled until the next reset.

**Figure 11.4. FLSCS: FLASH Scale Register**

R/W	R/W	R/W	R/W	R/W	R/W	R/W	R/W	Reset Value
FOSE	Reserved	Reserved	Reserved	Reserved	Reserved	Reserved	Reserved	10000000
Bit7	Bit6	Bit5	Bit4	Bit3	Bit2	Bit1	Bit0	SFR Address: 0xB6

Bits7: FOSE: FLASH One-shot Enable  
This bit enables the FLASH read one-shot. When the FLASH one-shot disabled, the FLASH sense amps are enabled for a full clock cycle during FLASH reads. At system clock frequencies below 10 MHz, disabling the FLASH one-shot will increase system power consumption.  
0: FLASH one-shot disabled.  
1: FLASH one-shot enabled.

Bits6-0: RESERVED. Read = 0. Must Write 0.

---

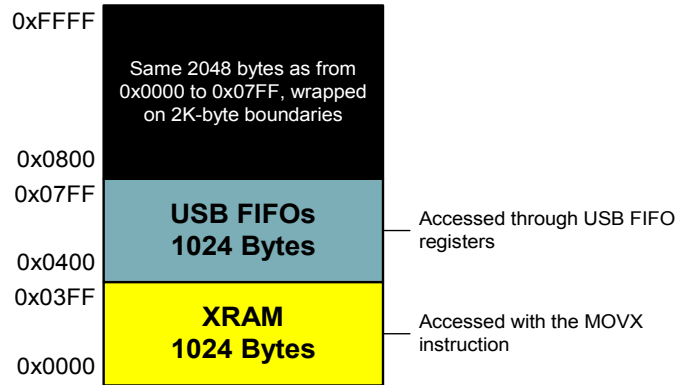
*Notes*



## 12. EXTERNAL RAM

The C8051F320/1 devices include 2048 bytes of on-chip XRAM. This XRAM space is split into user RAM (addresses 0x0000 - 0x03FF) and USB0 FIFO space (addresses 0x0400 - 0x07FF).

**Figure 12.1. External Ram Memory Map**



### 12.1. Accessing User XRAM

XRAM can be accessed using the external move instruction (MOVX) and the data pointer (DPTR), or using MOVX indirect addressing mode. If the MOVX instruction is used with an 8-bit address operand (such as @R1), then the high byte of the 16-bit address is provided by the External Memory Interface Control Register (EMI0CN as shown in Figure 12.3). Note: the MOVX instruction is also used for writes to the FLASH memory. See **Section “11. FLASH Memory” on page 107** for details. The MOVX instruction accesses XRAM by default.

For any of the addressing modes the upper 5 bits of the 16-bit external data memory address word are "don't cares". As a result, the 2048-byte RAM is mapped modulo style over the entire 64k external data memory address range. For example, the XRAM byte at address 0x0000 is also at address 0x0800, 0x1000, 0x1800, 0x2000, etc.

**Important Note:** The upper 1k of the 2k XRAM functions as USB FIFO space. See **Section 12.2** for details on accessing this memory space.

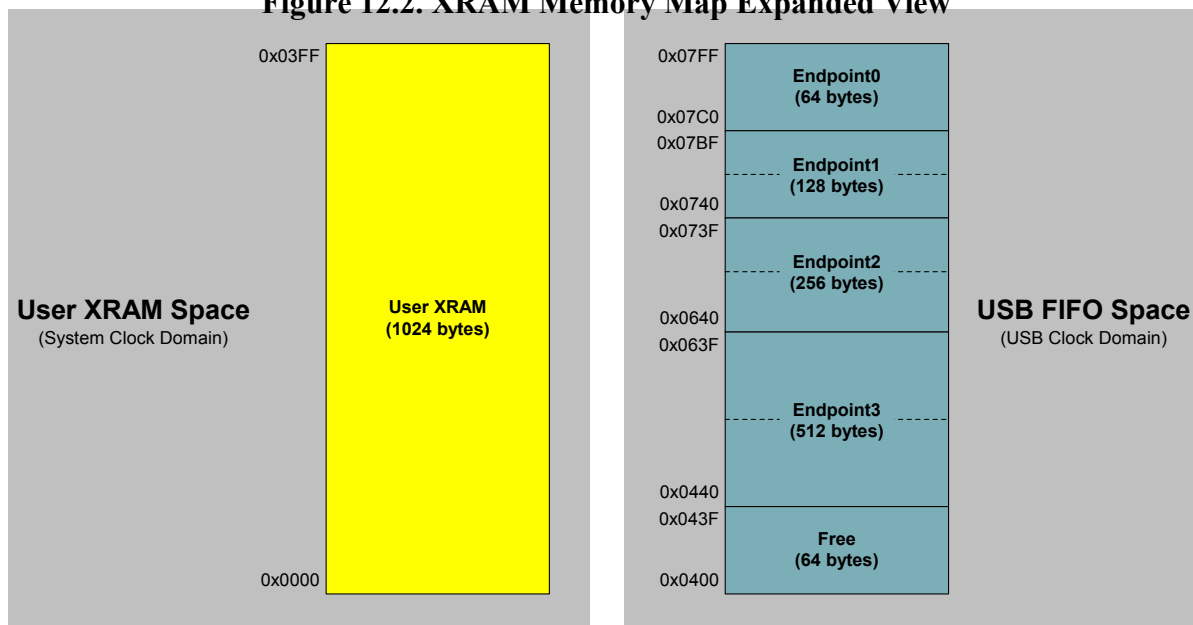
## 12.2. Accessing USB FIFO Space

The upper 1k of XRAM functions as USB FIFO space. Figure 12.2 shows an expanded view of the FIFO space and user XRAM. FIFO space is accessed via USB FIFO registers; see **Section “15.5. FIFO Management” on page 151** for more information on accessing these FIFOs. The MOVX instruction should not be used to load or modify USB data in the FIFO space.

Unused areas of the FIFO space may be used as general purpose XRAM, accessible as described in **Section 12.1**. The FIFO block operates on the USB clock domain; thus the USB clock must be active when accessing FIFO space. Note that the number of SYSCLK cycles required by the MOVX instruction is increased when accessing USB FIFO space.

**Important Note: The USB clock must be active when accessing FIFO space.**

**Figure 12.2. XRAM Memory Map Expanded View**



**Figure 12.3. EMI0CN: External Memory Interface Control**

R/W	R/W	R/W	R/W	R/W	R/W	R/W	R/W	Reset Value
-	-	-	-	-	PGSEL2	PGSEL1	PGSEL0	00000000
Bit7	Bit6	Bit5	Bit4	Bit3	Bit2	Bit1	Bit0	SFR Address: 0xAA

Bits7-3: Not Used - reads 00000b.  
 Bits2-0: PGSEL[2:0]: XRAM Page Select Bits.  
 The XRAM Page Select Bits provide the high byte of the 16-bit external data memory address when using an 8-bit MOVX command, effectively selecting a 256-byte page of RAM. The upper 5-bits are "don't cares", so the 2k address blocks are repeated modulo over the entire 64k external data memory address space.

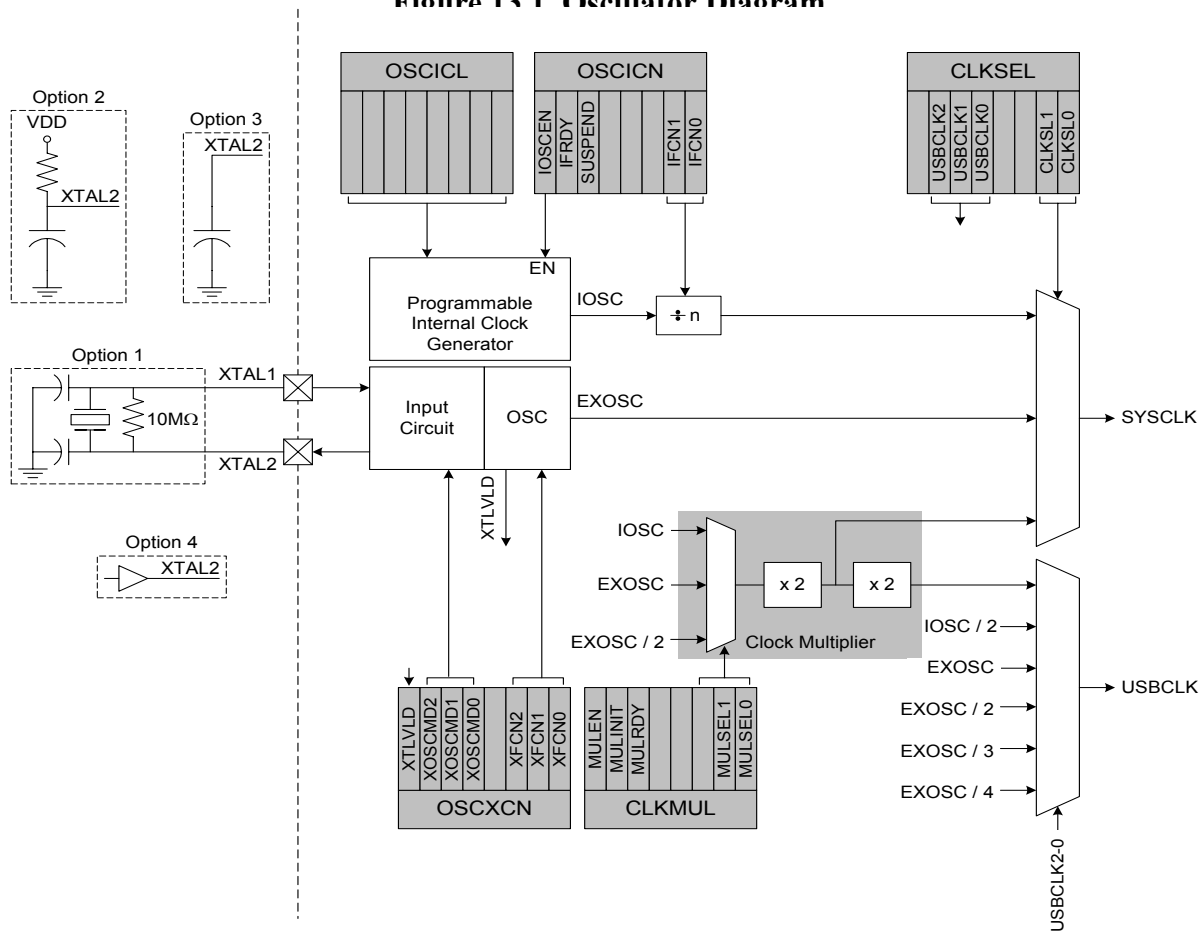
---

*Notes*

### 13. OSCILLATORS

C8051F320/1 devices include a programmable internal oscillator, an external oscillator drive circuit, and a 4x Clock Multiplier. The internal oscillator can be enabled/disabled and calibrated using the OSCICN and OSCICL registers, as shown in Figure 13.1. The system clock (SYSCLK) can be derived from the internal oscillator, external oscillator circuit, or the 4x Clock Multiplier divided by 2. The USB clock (USBCLK) can be derived from the internal oscillator, external oscillator, or 4x Clock Multiplier. Oscillator electrical specifications are given in Table 13.3 on page 126.

Figure 13.1 Oscillator Diagram



#### 13.1. Programmable Internal Oscillator

All C8051F320/1 devices include a programmable internal oscillator that defaults as the system clock after a system reset. The internal oscillator period can be programmed via the OSCICL register as defined by Equation 13.1, where  $f_{BASE}$  is the frequency of the internal oscillator following a reset,  $\Delta T$  is the change in internal oscillator period, and  $\Delta OSCICL$  is a change to the value held in register OSCICL.

Equation 13.1. Typical Change in Internal Oscillator Period with OSCICL

$$\Delta T \cong 0.0025 \times \frac{1}{f_{BASE}} \times \Delta OSCICL$$

# C8051F320/1

On C8051F320/1 devices, OSCICL is factory calibrated to obtain a 12 MHz base frequency ( $f_{BASE}$ ). **Section 13.1.1** details oscillator programming for C8051F320/1 devices. Electrical specifications for the precision internal oscillator are given in Table 13.3 on page 126. Note that the system clock may be derived from the programmed internal oscillator divided by 1, 2, 4, or 8, as defined by the IFCN bits in register OSCICN. The divide value defaults to 8 following a reset.

## 13.1.1. Programming the Internal Oscillator on C8051F320/1 Devices

The OSCICL reset value is factory calibrated to result in a 12 MHz internal oscillator with a  $\pm 1.5\%$  accuracy; this frequency is suitable for use as the USB clock (see **Section 13.4**). Software may modify the frequency of the internal oscillator as described below.

**Important Note:** Once the internal oscillator frequency has been modified, the internal oscillator may not be used as the USB clock as described in **Section 13.4**. The internal oscillator frequency will reset to its original factory-calibrated frequency following any device reset, at which point the oscillator is suitable for use as the USB clock.

Software should read and adjust the value of OSCICL according to Equation 13.1 to obtain the desired frequency. The example below shows how to obtain an 11.6 MHz internal oscillator frequency.

$f_{BASE}$  is the internal oscillator reset frequency;  $T_{BASE}$  is the reset oscillator period.  
 $f_{DES}$  is the desired internal oscillator frequency;  $T_{DES}$  is the desired oscillator period.

$$\begin{aligned} f_{BASE} &= 12000000\text{Hz} & f_{DES} &= 11600000\text{Hz} \\ T_{BASE} &= \frac{1}{12000000}\text{s} & T_{DES} &= \frac{1}{11600000}\text{s} \end{aligned}$$

The required change in period ( $\Delta T_{DES}$ ) is the difference between the base period and the desired period.

$$\Delta T_{DES} = \frac{1}{11600000} - \frac{1}{12000000} = 2.87 \times 10^{-9}\text{s}$$

Using Equation 13.1 and the above calculations, find  $\Delta OSCICL$ :

$$2.87 \times 10^{-9} = 0.0025 \times \frac{1}{f_{BASE}} \times \Delta OSCICL$$

$$\Delta OSCICL = 13.79$$

$\Delta OSCICL$  is rounded to the nearest integer (14) and added to the reset value of register OSCICL.

**Important Note:** If the sum of the reset value of OSCICL and  $\Delta OSCICL$  is greater than 31 or less than 0, then the device will not be capable of producing the desired frequency.

## 13.1.2. Internal Oscillator Suspend Mode

The internal oscillator may be placed in Suspend mode by writing ‘1’ to the SUSPEND bit in register OSCICN. In Suspend mode, the internal oscillator is stopped until a non-idle USB event is detected (**Section 15**) or VBUS matches the polarity selected by the VBPOL bit in register REG0CN (**Section 8.2**). Note that the USB transceiver must be enabled for a USB event to be detected.

**Figure 13.2. OSCICN: Internal Oscillator Control Register**

R/W	R	R/W	R	R/W	R/W	R/W	R/W	Reset Value
IOSCEN	IFRDY	SUSPEND	-	-	-	IFCN1	IFCN0	00010100
Bit7	Bit6	Bit5	Bit4	Bit3	Bit2	Bit1	Bit0	SFR Address: 0xB2

Bit7: IOSCEN: Internal Oscillator Enable Bit.  
0: Internal Oscillator Disabled.  
1: Internal Oscillator Enabled.

Bit6: IFRDY: Internal Oscillator Frequency Ready Flag.  
0: Internal Oscillator is not running at programmed frequency.  
1: Internal Oscillator is running at programmed frequency.

Bit5: SUSPEND: Force Suspend  
Writing a '1' to this bit will force the internal oscillator to be stopped. The oscillator will be re-started on the next non-idle USB event (i.e., RESUME signaling) or VBUS interrupt event (see Figure 8.5).

Bits4-2: UNUSED. Read = 000b, Write = don't care.

Bits1-0: IFCN1-0: Internal Oscillator Frequency Control Bits.  
00: SYSCLK derived from Internal Oscillator divided by 8.  
01: SYSCLK derived from Internal Oscillator divided by 4.  
10: SYSCLK derived from Internal Oscillator divided by 2.  
11: SYSCLK derived from Internal Oscillator divided by 1.

**Figure 13.3. OSCICL: Internal Oscillator Calibration Register**

R/W	R/W	R/W	R/W	R/W	R/W	R/W	R/W	Reset Value
-	-	-	OSCCAL				-	Variable
Bit7	Bit6	Bit5	Bit4	Bit3	Bit2	Bit1	Bit0	SFR Address: 0xB3

Bits4-0: OSCCAL: Oscillator Calibration Value  
These bits determine the internal oscillator period as per Equation 13.1.

**Note: The contents of this register are undefined when Clock Recovery is enabled. See Section “15.4. USB Clock Configuration” on page 150 for details on Clock Recovery.**

## 13.2. External Oscillator Drive Circuit

The external oscillator circuit may drive an external crystal, ceramic resonator, capacitor, or RC network. A CMOS clock may also provide a clock input. For a crystal or ceramic resonator configuration, the crystal/resonator must be wired across the XTAL1 and XTAL2 pins as shown in Option 1 of Figure 13.1. A 10 M $\Omega$  resistor also must be wired across the XTAL1 and XTAL2 pins for the crystal/resonator configuration. In RC, capacitor, or CMOS clock configuration, the clock source should be wired to the XTAL2 pin as shown in Option 2, 3, or 4 of Figure 13.1. The type of external oscillator must be selected in the OSCXCN register, and the frequency control bits (XFCN) must be selected appropriately (see Figure 13.4)

**Important Note on External Oscillator Usage:** Port pins must be configured when using the external oscillator circuit. When the external oscillator drive circuit is enabled in crystal/resonator mode, Port pins P0.2 and P0.3 are used as XTAL1 and XTAL2 respectively. When the external oscillator drive circuit is enabled in capacitor, RC, or CMOS clock mode, Port pin P0.3 is used as XTAL2. The Port I/O Crossbar should be configured to skip the Port pins used by the oscillator circuit; see [Section “14.1. Priority Crossbar Decoder” on page 129](#) for Crossbar configuration. Additionally, when using the external oscillator circuit in crystal/resonator, capacitor, or RC mode, the associated Port pins should be configured as **analog inputs**. In CMOS clock mode, the associated pin should be configured as a **digital input**. See [Section “14.2. Port I/O Initialization” on page 131](#) for details on Port input mode selection.

### 13.2.1. Clocking Timers Directly Through the External Oscillator

The external oscillator source divided by eight is a clock option for the timers ([Section “19. Timers” on page 217](#)) and the Programmable Counter Array (PCA) ([Section “20. Programmable Counter Array \(PCA0\)” on page 235](#)). When the external oscillator is used to clock these peripherals, but is not used as the system clock, the external oscillator frequency must be less than or equal to the system clock frequency. In this configuration, the clock supplied to the peripheral (external oscillator / 8) is synchronized with the system clock; the jitter associated with this synchronization is limited to  $\pm 0.5$  system clock cycles.

### 13.2.2. External Crystal Example

If a crystal or ceramic resonator is used as an external oscillator source for the MCU, the circuit should be configured as shown in Figure 13.1, Option 1. The External Oscillator Frequency Control value (XFCN) should be chosen from the Crystal column of the table in Figure 13.4 (OSCXCN register). For example, a 12 MHz crystal requires an XFCN setting of 111b.

When the crystal oscillator is first enabled, the oscillator amplitude detection circuit requires a settling time to achieve proper bias. Introducing a delay of 1 ms between enabling the oscillator and checking the XTLVLD bit will prevent a premature switch to the external oscillator as the system clock. Switching to the external oscillator before the crystal oscillator has stabilized can result in unpredictable behavior. The recommended procedure is:

- Step 1. Enable the external oscillator.
- Step 2. Wait at least 1 ms.
- Step 3. Poll for XTLVLD => ‘1’.
- Step 4. Switch the system clock to the external oscillator.

**Important Note on External Crystals:** Crystal oscillator circuits are quite sensitive to PCB layout. The crystal should be placed as close as possible to the XTAL pins on the device. The traces should be as short as possible and shielded with ground plane from any other traces which could introduce noise or interference.



### 13.2.3. External RC Example

If an RC network is used as an external oscillator source for the MCU, the circuit should be configured as shown in Figure 13.1, Option 2. The capacitor should be no greater than 100 pF; however for very small capacitors, the total capacitance may be dominated by parasitic capacitance in the PCB layout. To determine the required External Oscillator Frequency Control value (XFCN) in the OSCXCN Register, first select the RC network value to produce the desired frequency of oscillation. If the frequency desired is 100 kHz, let  $R = 246 \text{ k}\Omega$  and  $C = 50 \text{ pF}$ :

$$f = 1.23(10^3) / RC = 1.23(10^3) / [246 * 50] = 0.1 \text{ MHz} = 100 \text{ kHz}$$

Referring to the table in Figure 13.4, the required XFCN setting is 010b. Programming XFCN to a higher setting in RC mode will improve frequency accuracy at an increased external oscillator supply current.

### 13.2.4. External Capacitor Example

If a capacitor is used as an external oscillator for the MCU, the circuit should be configured as shown in Figure 13.1, Option 3. The capacitor should be no greater than 100 pF; however for very small capacitors, the total capacitance may be dominated by parasitic capacitance in the PCB layout. To determine the required External Oscillator Frequency Control value (XFCN) in the OSCXCN Register, select the capacitor to be used and find the frequency of oscillation from the equations below. Assume  $V_{DD} = 3.0 \text{ V}$  and  $C = 50 \text{ pF}$ :

$$f = KF / (C * V_{DD}) = KF / (50 * 3) \text{ MHz}$$
$$f = KF / 150 \text{ MHz}$$

If a frequency of roughly 150 kHz is desired, select the K Factor from the table in Figure 13.4 as  $KF = 22$ :

$$f = 22 / 150 = 0.146 \text{ MHz, or } 146 \text{ kHz}$$

Therefore, the XFCN value to use in this example is 011b.

**Figure 13.4. OSCXCN: External Oscillator Control Register**

R	R/W	R/W	R/W	R	R/W	R/W	R/W	Reset Value
XTLVLD	XOSCMD2	XOSCMD1	XOSCMD0	-	XFCN2	XFCN1	XFCN0	00000000
Bit7	Bit6	Bit5	Bit4	Bit3	Bit2	Bit1	Bit0	SFR Address: 0xB1

Bit7: XTLVLD: Crystal Oscillator Valid Flag.  
(Read only when XOSCMD = 11x.)  
0: Crystal Oscillator is unused or not yet stable.  
1: Crystal Oscillator is running and stable.

Bits6-4: XOSCMD2-0: External Oscillator Mode Bits.  
00x: External Oscillator circuit off.  
010: External CMOS Clock Mode.  
011: External CMOS Clock Mode with divide by 2 stage.  
100: RC Oscillator Mode.  
101: Capacitor Oscillator Mode.  
110: Crystal Oscillator Mode.  
111: Crystal Oscillator Mode with divide by 2 stage.

Bit3: RESERVED. Read = 0, Write = don't care.

Bits2-0: XFCN2-0: External Oscillator Frequency Control Bits.  
000-111: See table below:

XFCN	Crystal (XOSCMD = 11x)	RC (XOSCMD = 10x)	C (XOSCMD = 10x)
000	$f \leq 32\text{kHz}$	$f \leq 25\text{kHz}$	K Factor = 0.87
001	$32\text{kHz} < f \leq 84\text{kHz}$	$25\text{kHz} < f \leq 50\text{kHz}$	K Factor = 2.6
010	$84\text{kHz} < f \leq 225\text{kHz}$	$50\text{kHz} < f \leq 100\text{kHz}$	K Factor = 7.7
011	$225\text{kHz} < f \leq 590\text{kHz}$	$100\text{kHz} < f \leq 200\text{kHz}$	K Factor = 22
100	$590\text{kHz} < f \leq 1.5\text{MHz}$	$200\text{kHz} < f \leq 400\text{kHz}$	K Factor = 65
101	$1.5\text{MHz} < f \leq 4\text{MHz}$	$400\text{kHz} < f \leq 800\text{kHz}$	K Factor = 180
110	$4\text{MHz} < f \leq 10\text{MHz}$	$800\text{kHz} < f \leq 1.6\text{MHz}$	K Factor = 664
111	$10\text{MHz} < f \leq 30\text{MHz}$	$1.6\text{MHz} < f \leq 3.2\text{MHz}$	K Factor = 1590

**CRYSTAL MODE** (Circuit from Figure 13.1, Option 1; XOSCMD = 11x)  
Choose XFCN value to match crystal or resonator frequency.

**RC MODE** (Circuit from Figure 13.1, Option 2; XOSCMD = 10x)  
Choose XFCN value to match frequency range:  
 $f = 1.23(10^3) / (R * C)$ , where  
f = frequency of clock in MHz  
C = capacitor value in pF  
R = Pull-up resistor value in kΩ

**C MODE** (Circuit from Figure 13.1, Option 3; XOSCMD = 10x)  
Choose K Factor (KF) for the oscillation frequency desired:  
 $f = KF / (C * VDD)$ , where  
f = frequency of clock in MHz  
C = capacitor value the XTAL2 pin in pF  
VDD = Power Supply on MCU in volts

## 13.3. 4x Clock Multiplier

The 4x Clock Multiplier allows a 12 MHz oscillator to generate the 48 MHz clock required for Full Speed USB communication (see **Section “15.4. USB Clock Configuration” on page 150**). A divided version of the Multiplier output can also be used as the system clock. See **Section 13.4** for details on system clock and USB clock source selection.

The 4x Clock Multiplier is configured via the CLKMUL register. The procedure for configuring and enabling the 4x Clock Multiplier is as follows:

1. Reset the Multiplier by writing 0x00 to register CLKMUL.
2. Select the Multiplier input source via the MULSEL bits.
3. Enable the Multiplier with the MULEN bit (CLKMUL |= 0x80).
4. Delay for >5 μs.
5. Initialize the Multiplier with the MULINIT bit (CLKMUL |= 0xC0).
6. Poll for MULRDY => ‘1’.

**Important Note: When using an external oscillator as the input to the 4x Clock Multiplier, the external source must be enabled and stable before the Multiplier is initialized. See Section 13.4 for details on selecting an external oscillator source.**

**Figure 13.5. CLKMUL: Clock Multiplier Control Register**

	R/W	R/W	R	R/W	R/W	R/W	R/W	R/W	Reset Value
	MULEN	MULINIT	MULRDY	-	-	-	MULSEL		00000000
	Bit7	Bit6	Bit5	Bit4	Bit3	Bit2	Bit1	Bit0	SFR Address 0xB9
Bit7:	MULEN: Clock Multiplier Enable 0: Clock Multiplier disabled. 1: Clock Multiplier enabled.								
Bit6:	MULINIT: Clock Multiplier Initialize This bit should be a ‘0’ when the Clock Multiplier is enabled. Once enabled, writing a ‘1’ to this bit will initialize the Clock Multiplier. The MULRDY bit reads ‘1’ when the Clock Multiplier is stabilized.								
Bit5:	MULRDY: Clock Multiplier Ready This read-only bit indicates the status of the Clock Multiplier. 0: Clock Multiplier not ready. 1: Clock Multiplier ready (locked).								
Bits4-2:	Unused. Read = 000b; Write = don’t care.								
Bits1-0:	MULSEL: Clock Multiplier Input Select These bits select the clock supplied to the Clock Multiplier.								

MULSEL	Selected Clock
00	Internal Oscillator
01	External Oscillator
10	External Oscillator / 2
11	RESERVED

## 13.4. System and USB Clock Selection

The internal oscillator requires little start-up time and may be selected as the system or USB clock immediately following the OSCICN write that enables the internal oscillator. External crystals and ceramic resonators typically require a start-up time before they are settled and ready for use. The Crystal Valid Flag (XTLVLD in register OSCXCN) is set to '1' by hardware when the external oscillator is settled. **To avoid reading a false XTLVLD, in crystal mode software should delay at least 1 ms between enabling the external oscillator and checking XTLVLD.** RC and C modes typically require no startup time.

### 13.4.1. System Clock Selection

The CLKSL[1:0] bits in register CLKSEL select which oscillator source is used as the system clock. CLKSL[1:0] must be set to 01b for the system clock to run from the external oscillator; however the external oscillator may still clock certain peripherals (timers, PCA, USB) when the internal oscillator is selected as the system clock. The system clock may be switched on-the-fly between the internal oscillator, external oscillator, and 4x Clock Multiplier so long as the selected oscillator is enabled and has settled.

### 13.4.2. USB Clock Selection

The USBCLK[2:0] bits in register CLKSEL select which oscillator source is used as the USB clock. The USB clock may be derived from the 4x Clock Multiplier output, a divided version of the internal oscillator, or a divided version of the external oscillator. Note that the USB clock must be 48 MHz when operating USB0 as a Full Speed Function; the USB clock must be 6 MHz when operating USB0 as a Low Speed Function. See Figure 13.6 for USB clock selection options.

Some example USB clock configurations for Full and Low Speed mode are given below:

**Table 13.1. Typical USB Full Speed Clock Settings**

Internal Oscillator		
Clock Signal	Input Source Selection	Register Bit Settings
USB Clock	Clock Multiplier	USBCLK = 000b
Clock Multiplier Input	Internal Oscillator <sup>†</sup>	MULSEL = 00b
Internal Oscillator	Divide by 1	IFCN = 11b
External Oscillator		
Clock Signal	Input Source Selection	Register Bit Settings
USB Clock	Clock Multiplier	USBCLK = 000b
Clock Multiplier Input	External Oscillator	MULSEL = 01b
External Oscillator	Crystal Oscillator Mode 12 MHz Crystal	XOSCMD = 110b XFCN = 111b

<sup>†</sup>Clock Recovery must be enabled for this configuration.

**Table 13.2. Typical USB Low Speed Clock Settings**

Internal Oscillator		
Clock Signal	Input Source Selection	Register Bit Settings
USB Clock	Internal Oscillator / 2	USBCLK = 001b
Internal Oscillator	Divide by 1	IFCN = 11b
External Oscillator		
Clock Signal	Input Source Selection	Register Bit Settings
USB Clock	External Oscillator / 4	USBCLK = 101b
External Oscillator	Crystal Oscillator Mode 24 MHz Crystal	XOSCMD = 110b XFCN = 111b

**Figure 13.6. CLKSEL: Clock Select Register**

R/W	R/W	R/W	R/W	R/W	R/W	R/W	R/W	Reset Value
-	USBCLK			-	-	CLKSL		00000000
Bit7	Bit6	Bit5	Bit4	Bit3	Bit2	Bit1	Bit0	SFR Address 0xA9

Bit 7: Unused. Read = 0b; Write = don't care.

Bits6-4: USBCLK2-0: USB Clock Select  
 These bits select the clock supplied to USB0. When operating USB0 in full-speed mode, the selected clock should be 48 MHz. When operating USB0 in low-speed mode, the selected clock should be 6 MHz.

USBCLK	Selected Clock
000	4x Clock Multiplier
001	Internal Oscillator / 2
010	External Oscillator
011	External Oscillator / 2
100	External Oscillator / 3
101	External Oscillator / 4
110	RESERVED
111	RESERVED

Bits3-2: Unused. Read = 00b; Write = don't care.

Bits1-0: CLKSL1-0: System Clock Select  
 These bits select the system clock source.

CLKSL	Selected Clock
00	Internal Oscillator (as determined by the IFCN bits in register OSCICN)
01	External Oscillator
10	4x Clock Multiplier / 2
11	RESERVED

**Table 13.3. Internal Oscillator Electrical Characteristics**

-40°C to +85°C unless otherwise specified

PARAMETER	CONDITIONS	MIN	TYP	MAX	UNITS
Internal Oscillator Frequency	Reset Frequency	11.82	12	12.18	MHz
Internal Oscillator Supply Current (from VDD)	OSCICN.7 = 1		450		μA
USB Clock Frequency <sup>†</sup>	Full Speed Mode	47.88	48	48.12	MHz
	Low Speed Mode	5.91	6	6.09	

<sup>†</sup>Applies only to external oscillator sources.

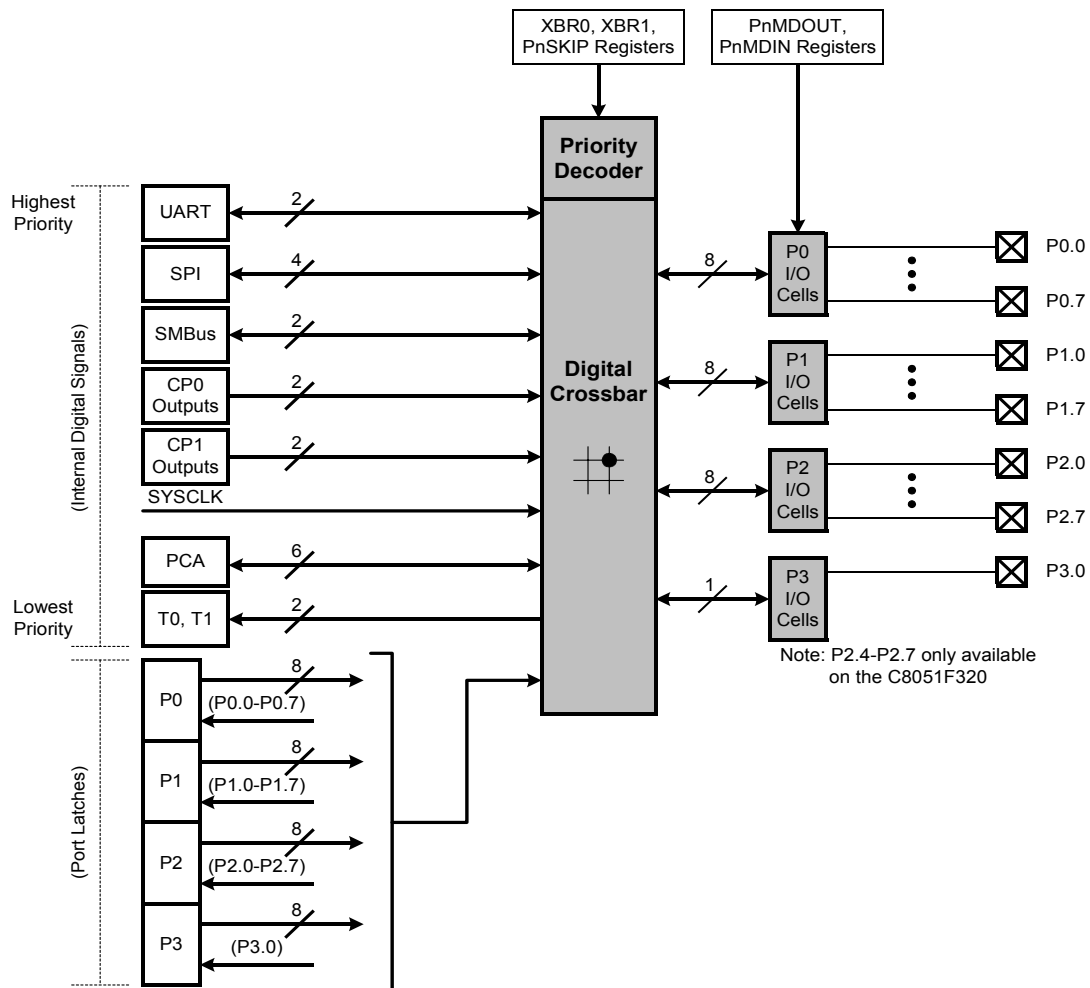
## 14. PORT INPUT/OUTPUT

Digital and analog resources are available through 25 I/O pins (C8051F320) or 21 I/O pins (C8051F321). Port pins are organized as shown in Figure 14.1. Each of the Port pins can be defined as general-purpose I/O (GPIO) or analog input; Port pins P0.0-P2.3 can be assigned to one of the internal digital resources as shown in Figure 14.3. The designer has complete control over which functions are assigned, limited only by the number of physical I/O pins. This resource assignment flexibility is achieved through the use of a Priority Crossbar Decoder. Note that the state of a Port I/O pin can always be read in the corresponding Port latch, regardless of the Crossbar settings.

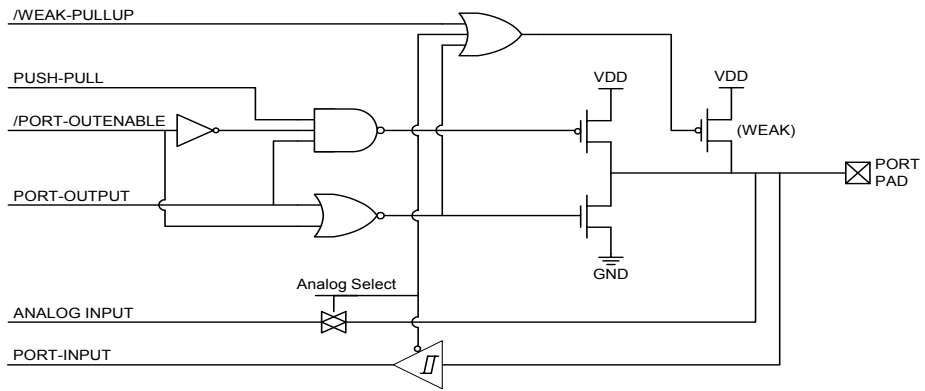
The Crossbar assigns the selected internal digital resources to the I/O pins based on the Priority Decoder (Figure 14.3 and Figure 14.4). The registers XBR0 and XBR1, defined in Figure 14.5 and Figure 14.6, are used to select internal digital functions.

All Port I/Os are 5 V tolerant (refer to Figure 14.2 for the Port cell circuit). The Port I/O cells are configured as either push-pull or open-drain in the Port Output Mode registers (PnMDOUT, where n = 0,1,2,3). Complete Electrical Specifications for Port I/O are given in Table 14.1 on page 142.

**Figure 14.1. Port I/O Functional Block Diagram**



**Figure 14.2. Port I/O Cell Block Diagram**






## 14.1. Priority Crossbar Decoder


The Priority Crossbar Decoder (Figure 14.3) assigns a priority to each I/O function, starting at the top with UART0. When a digital resource is selected, the least-significant unassigned Port pin is assigned to that resource (excluding UART0, which is always at pins 4 and 5). If a Port pin is assigned, the Crossbar skips that pin when assigning the next selected resource. Additionally, the Crossbar will skip Port pins whose associated bits in the PnSKIP registers are set. The PnSKIP registers allow software to skip Port pins that are to be used for analog input, dedicated functions, or GPIO.

**Important Note on Crossbar Configuration:** If a Port pin is claimed by a peripheral without use of the Crossbar, its corresponding PnSKIP bit should be set. This applies to P0.7 if VREF is used, P0.3 and/or P0.2 if the external oscillator circuit is enabled, P0.6 if the ADC is configured to use the external conversion start signal (CNVSTR), and any selected ADC or Comparator inputs. The Crossbar skips selected pins as if they were already assigned, and moves to the next unassigned pin. Figure 14.3 shows the Crossbar Decoder priority with no Port pins skipped (P0SKIP, P1SKIP, P2SKIP = 0x00); Figure 14.4 shows the Crossbar Decoder priority with the XTAL1 (P0.2) and XTAL2 (P0.3) pins skipped (P0SKIP = 0x0C).

Figure 14.3. Crossbar Priority Decoder with No Pins Skipped

	P0								P1								P2									
SF Signals	XTAL1		XTAL2		CNVSTR		VREF																			
PIN I/O	0	1	2	3	4	5	6	7	0	1	2	3	4	5	6	7	0	1	2	3	4	5	6	7		
TX0																										
RX0																										
SCK																										
MISO																										
MOSI																										
NSS*									*NSS is only pinned out in 4-wire SPI mode																	
SDA																										
SCL																										
CP0																										
CP0A																										
CP1																										
CP1A																										
SYSCLK																										
CEX0																										
CEX1																										
CEX2																										
CEX3																										
CEX4																										
ECI																										
T0																										
T1																										
	0	0	0	0	0	0	0	0	0	0	0	0	0	0	0	0	0	0	0	0	0	0	0	0		
	P0SKIP[0:7]								P1SKIP[0:7]								P2SKIP[0:3]									

 Port pin potentially available to peripheral


 **SF Signals** Special Function Signals are not assigned by the Crossbar. When these signals are enabled, the Crossbar must be manually configured to skip their corresponding port pins.


Signals Unavailable

**Figure 14.4. Crossbar Priority Decoder with Crystal Pins Skipped**

	P0							P1							P2									
SF Signals	XTAL1		XTAL2		CNVSTR		VREF																	
PIN I/O	0	1	2	3	4	5	6	7	0	1	2	3	4	5	6	7	0	1	2	3	4	5	6	7
TX0																								
RX0																								
SCK																								
MISO																								
MOSI																								
NSS*																								
SDA																								
SCL																								
CP0																								
CP0A																								
CP1																								
CP1A																								
SYSCLK																								
CEX0																								
CEX1																								
CEX2																								
CEX3																								
CEX4																								
ECI																								
T0																								
T1																								
	0	0	1	1	0	0	0	0	0	0	0	0	0	0	0	0	0	0	0	0	0	0	0	0
	P0SKIP[0:7]							P1SKIP[0:7]							P2SKIP[0:3]									

Signals Unavailable

 Port pin potentially available to peripheral

 **SF Signals** Special Function Signals are not assigned by the Crossbar. When these signals are enabled, the Crossbar must be manually configured to skip their corresponding port pins.

Registers XBR0 and XBR1 are used to assign the digital I/O resources to the physical I/O Port pins. Note that when the SMBus is selected, the Crossbar assigns both pins associated with the SMBus (SDA and SCL); when the UART is selected, the Crossbar assigns both pins associated with the UART (TX and RX). UART0 pin assignments are fixed for bootloading purposes: UART TX0 is always assigned to P0.4; UART RX0 is always assigned to P0.5. Standard Port I/Os appear contiguously after the prioritized functions have been assigned.

**Important Note:** The SPI can be operated in either 3-wire or 4-wire modes, depending on the state of the NSSMD1-NSSMD0 bits in register SPI0CN. According to the SPI mode, the NSS signal may or may not be routed to a Port pin.

---

## 14.2. Port I/O Initialization

Port I/O initialization consists of the following steps:

- Step 1. Select the input mode (analog or digital) for all Port pins, using the Port Input Mode register (PnMDIN).
- Step 2. Select the output mode (open-drain or push-pull) for all Port pins, using the Port Output Mode register (PnMDOUT).
- Step 3. Select any pins to be skipped by the I/O Crossbar using the Port Skip registers (PnSKIP).
- Step 4. Assign Port pins to desired peripherals (XBR0, XBR1).
- Step 5. Enable the Crossbar (XBARE = '1').

All Port pins must be configured as either analog or digital inputs. Any pins to be used as Comparator or ADC inputs should be configured as an analog inputs. When a pin is configured as an analog input, its weak pull-up, digital driver, and digital receiver are disabled. This process saves power and reduces noise on the analog input. Pins configured as digital inputs may still be used by analog peripherals; however this practice is not recommended. To configure a Port pin for digital input, write '0' to the corresponding bit in register PnMDOUT, and write '1' to the corresponding Port latch (register Pn).

Additionally, all analog input pins should be configured to be skipped by the Crossbar (accomplished by setting the associated bits in PnSKIP). Port input mode is set in the PnMDIN register, where a '1' indicates a digital input, and a '0' indicates an analog input. All pins default to digital inputs on reset. See Figure 14.8 for the PnMDIN register details.

The output driver characteristics of the I/O pins are defined using the Port Output Mode registers (PnMDOUT). Each Port Output driver can be configured as either open drain or push-pull. This selection is required even for the digital resources selected in the XBRn registers, and is not automatic. The only exception to this is the SMBus (SDA, SCL) pins, which are configured as open-drain regardless of the PnMDOUT settings. When the WEAKPUD bit in XBR1 is '0', a weak pull-up is enabled for all Port I/O configured as open-drain. WEAKPUD does not affect the push-pull Port I/O. Furthermore, the weak pull-up is turned off on an output that is driving a '0' to avoid unnecessary power dissipation.

Registers XBR0 and XBR1 must be loaded with the appropriate values to select the digital I/O functions required by the design. Setting the XBARE bit in XBR1 to '1' enables the Crossbar. Until the Crossbar is enabled, the external pins remain as standard Port I/O (in input mode), regardless of the XBRn Register settings. For given XBRn Register settings, one can determine the I/O pin-out using the Priority Decode Table; as an alternative, the Configuration Wizard utility of the Silicon Labs IDE software will determine the Port I/O pin-assignments based on the XBRn Register settings.

**Important Note:** The Crossbar must be enabled to use Ports P0, P1, and P2.0-P2.3 as standard Port I/O in output mode. These Port output drivers are disabled while the Crossbar is disabled. P2.4-P2.7 and P3.0 always function as standard GPIO.

**Figure 14.5. XBR0: Port I/O Crossbar Register 0**

R/W	R/W	R/W	R/W	R/W	R/W	R/W	R/W	Reset Value
CP1AE	CP1E	CP0AE	CP0E	SYSCKE	SMB0E	SPI0E	URT0E	00000000
Bit7	Bit6	Bit5	Bit4	Bit3	Bit2	Bit1	Bit0	SFR Address: 0xE1
Bit7:	CP1AE: Comparator1 Asynchronous Output Enable 0: Asynchronous CP1 unavailable at Port pin. 1: Asynchronous CP1 routed to Port pin.							
Bit6:	CP1E: Comparator1 Output Enable 0: CP1 unavailable at Port pin. 1: CP1 routed to Port pin.							
Bit5:	CP0AE: Comparator0 Asynchronous Output Enable 0: Asynchronous CP0 unavailable at Port pin. 1: Asynchronous CP0 routed to Port pin.							
Bit4:	CP0E: Comparator0 Output Enable 0: CP0 unavailable at Port pin. 1: CP0 routed to Port pin.							
Bit3:	SYSCKE: /SYSCLK Output Enable 0: /SYSCLK unavailable at Port pin. 1: /SYSCLK output routed to Port pin.							
Bit2:	SMB0E: SMBus I/O Enable 0: SMBus I/O unavailable at Port pins. 1: SMBus I/O routed to Port pins.							
Bit1:	SPI0E: SPI I/O Enable 0: SPI I/O unavailable at Port pins. 1: SPI I/O routed to Port pins.							
Bit0:	URT0E: UART I/O Output Enable 0: UART I/O unavailable at Port pin. 1: UART TX0, RX0 routed to Port pins P0.4 and P0.5.							

**Figure 14.6. XBR1: Port I/O Crossbar Register 1**

R/W	R/W	R/W	R/W	R/W	R/W	R/W	R/W	Reset Value
WEAKPUD	XBARE	T1E	T0E	ECIE	PCA0ME			00000000
Bit7	Bit6	Bit5	Bit4	Bit3	Bit2	Bit1	Bit0	SFR Address: 0xE2
<p>Bit7: WEAKPUD: Port I/O Weak Pull-up Disable. 0: Weak Pull-ups enabled (except for Ports whose I/O are configured as analog input or push-pull output). 1: Weak Pull-ups disabled.</p> <p>Bit6: XBARE: Crossbar Enable. 0: Crossbar disabled; all Port drivers disabled. 1: Crossbar enabled.</p> <p>Bit5: T1E: T1 Enable 0: T1 unavailable at Port pin. 1: T1 routed to Port pin.</p> <p>Bit4: T0E: T0 Enable 0: T0 unavailable at Port pin. 1: T0 routed to Port pin.</p> <p>Bit3: ECIE: PCA0 External Counter Input Enable 0: ECI unavailable at Port pin. 1: ECI routed to Port pin.</p> <p>Bits2-0: PCA0ME: PCA Module I/O Enable Bits. 000: All PCA I/O unavailable at Port pins. 001: CEX0 routed to Port pin. 010: CEX0, CEX1 routed to Port pins. 011: CEX0, CEX1, CEX2 routed to Port pins. 100: CEX0, CEX1, CEX2, CEX3 routed to Port pins. 101: CEX0, CEX1, CEX2, CEX3, CEX4 routed to Port pins. 110: Reserved. 111: Reserved.</p>								

## 14.3. General Purpose Port I/O

Port pins that remain unassigned by the Crossbar and are not used by analog peripherals can be used for general purpose I/O. Ports3-0 are accessed through corresponding special function registers (SFRs) that are both byte addressable and bit addressable. When writing to a Port, the value written to the SFR is latched to maintain the output data value at each pin. When reading, the logic levels of the Port's input pins are returned regardless of the XBRn settings (i.e., even when the pin is assigned to another signal by the Crossbar, the Port register can always read its corresponding Port I/O pin). The exception to this is the execution of the read-modify-write instructions. The read-modify-write instructions when operating on a Port SFR are the following: ANL, ORL, XRL, JBC, CPL, INC, DEC, DJNZ and MOV, CLR or SETB, when the destination is an individual bit in a Port SFR. For these instructions, the value of the register (not the pin) is read, modified, and written back to the SFR.

**Figure 14.7. P0: Port0 Register**

R/W	R/W	R/W	R/W	R/W	R/W	R/W	R/W	Reset Value
P0.7	P0.6	P0.5	P0.4	P0.3	P0.2	P0.1	P0.0	11111111
Bit7	Bit6	Bit5	Bit4	Bit3	Bit2	Bit1	Bit0	SFR Address:
								(bit addressable) 0x80

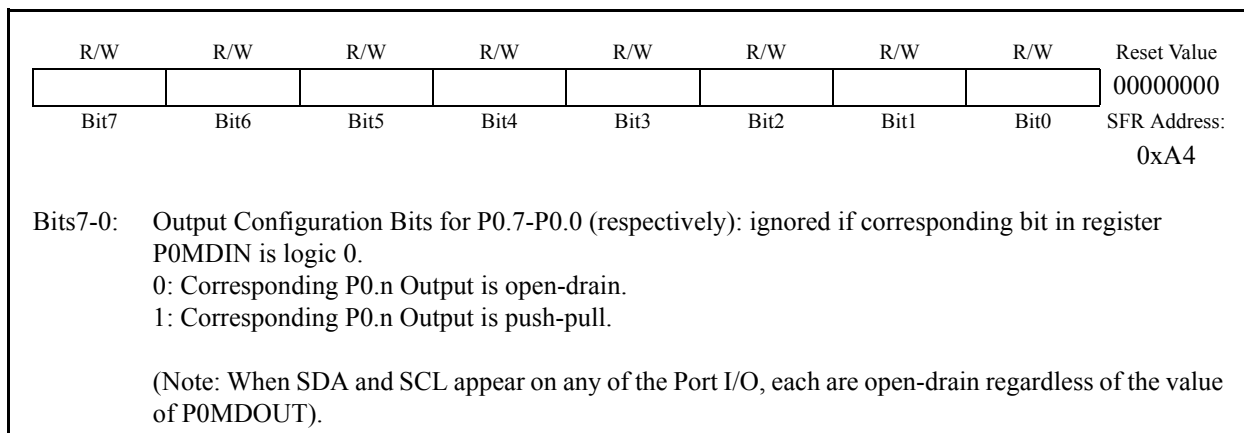
Bits7-0: P0.[7:0]  
 Write - Output appears on I/O pins per Crossbar Registers (when XBARE = '1').  
 0: Logic Low Output.  
 1: Logic High Output (high impedance if corresponding P0MDOUT.n bit = 0).  
 Read - Always reads '0' if selected as analog input in register P0MDIN. Directly reads Port pin when configured as digital input.  
 0: P0.n pin is logic low.  
 1: P0.n pin is logic high.

**Figure 14.8. P0MDIN: Port0 Input Mode Register**

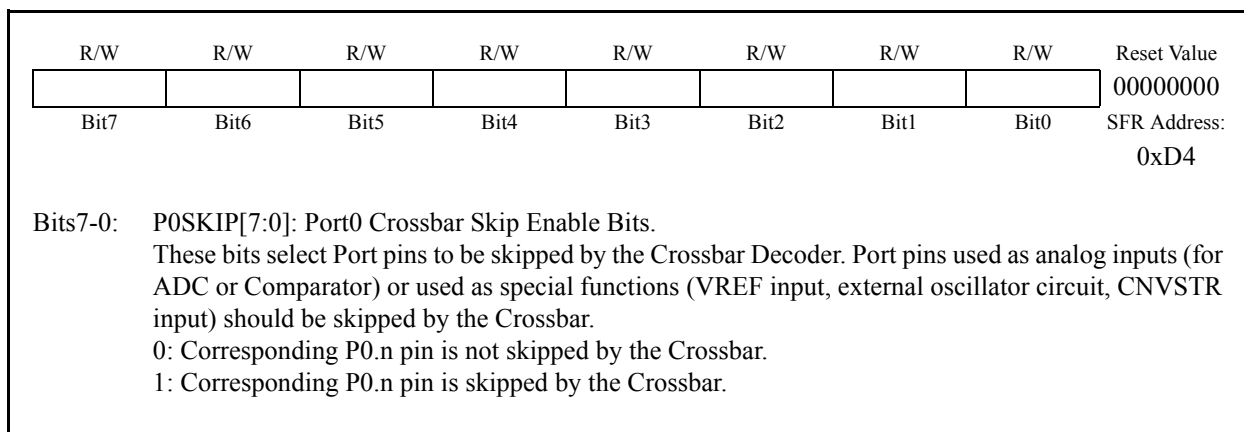
R/W	R/W	R/W	R/W	R/W	R/W	R/W	R/W	Reset Value
								11111111
Bit7	Bit6	Bit5	Bit4	Bit3	Bit2	Bit1	Bit0	SFR Address:
								0xF1

Bits7-0: Analog Input Configuration Bits for P0.7-P0.0 (respectively).  
 Port pins configured as analog inputs have their weak pull-up, digital driver, and digital receiver disabled.  
 0: Corresponding P0.n pin is configured as an analog input.  
 1: Corresponding P0.n pin is not configured as an analog input.

**Figure 14.9. P0MDOUT: Port0 Output Mode Register**



**Figure 14.10. P0SKIP: Port0 Skip Register**





**Figure 14.11. P1: Port1 Register**

R/W	R/W	R/W	R/W	R/W	R/W	R/W	R/W	Reset Value
P1.7	P1.6	P1.5	P1.4	P1.3	P1.2	P1.1	P1.0	11111111
Bit7	Bit6	Bit5	Bit4	Bit3	Bit2	Bit1	Bit0	SFR Address: (bit addressable) 0x90

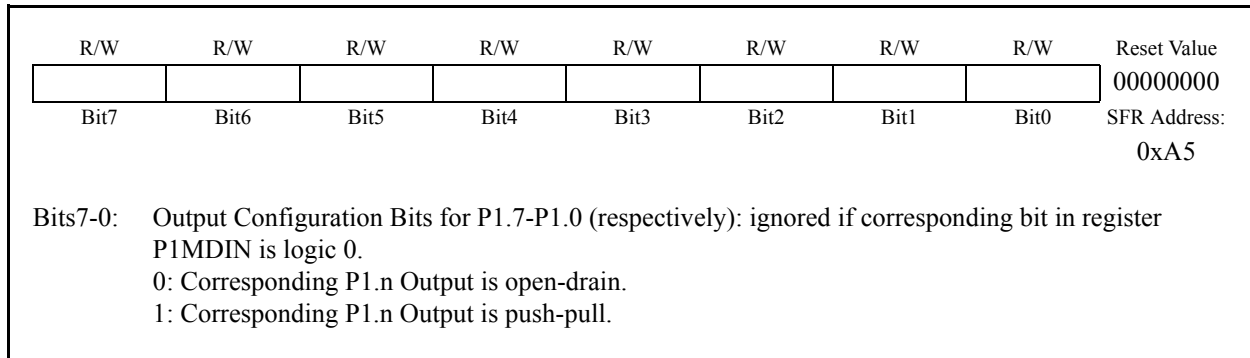
Bits7-0: P1.[7:0]  
 Write - Output appears on I/O pins per Crossbar Registers (when XBARE = '1').  
 0: Logic Low Output.  
 1: Logic High Output (high impedance if corresponding P1MDOUT.n bit = 0).  
 Read - Always reads '0' if selected as analog input in register P1MDIN. Directly reads Port pin when configured as digital input.  
 0: P1.n pin is logic low.  
 1: P1.n pin is logic high.

**Figure 14.12. P1MDIN: Port1 Input Mode Register**

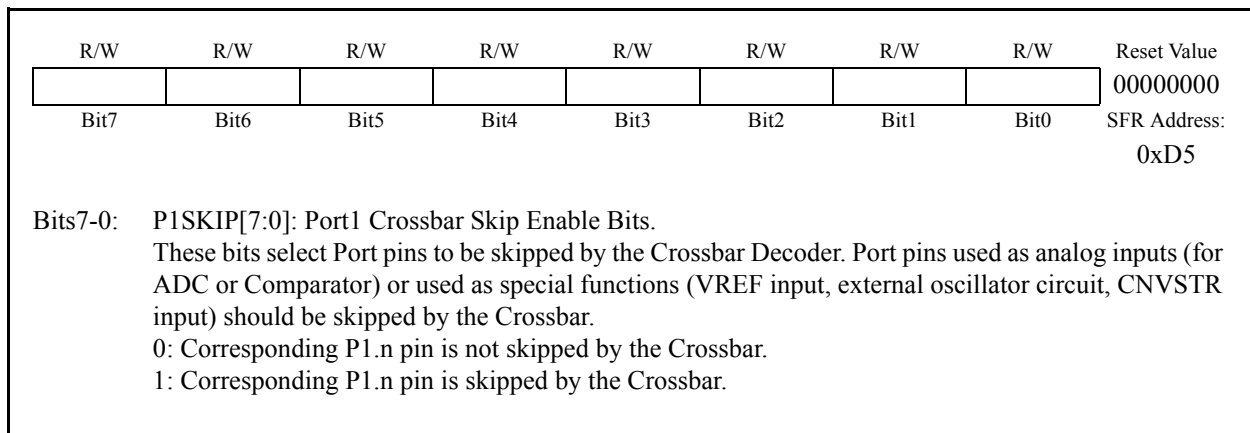
R/W	R/W	R/W	R/W	R/W	R/W	R/W	R/W	Reset Value
								11111111
Bit7	Bit6	Bit5	Bit4	Bit3	Bit2	Bit1	Bit0	SFR Address: 0xF2

Bits7-0: Analog Input Configuration Bits for P1.7-P1.0 (respectively).  
 Port pins configured as analog inputs have their weak pull-up, digital driver, and digital receiver disabled.  
 0: Corresponding P1.n pin is configured as an analog input.  
 1: Corresponding P1.n pin is not configured as an analog input.

**Figure 14.13. P1MDOUT: Port1 Output Mode Register**



**Figure 14.14. P1SKIP: Port1 Skip Register**



**Figure 14.15. P2: Port2 Register**

R/W	R/W	R/W	R/W	R/W	R/W	R/W	R/W	Reset Value
P2.7	P2.6	P2.5	P2.4	P2.3	P2.2	P2.1	P2.0	11111111
Bit7	Bit6	Bit5	Bit4	Bit3	Bit2	Bit1	Bit0	SFR Address:
								(bit addressable) 0xA0

Bits7-0: P2.[7:0]  
 Write - Output appears on I/O pins per Crossbar Registers (when XBARE = '1').  
 0: Logic Low Output.  
 1: Logic High Output (high impedance if corresponding P2MDOUT.n bit = 0).  
 Read - Always reads '0' if selected as analog input in register P2MDIN. Directly reads Port pin when configured as digital input.  
 0: P2.n pin is logic low.  
 1: P2.n pin is logic high.

*Note: P2.7-P2.4 only available on C8051F320 devices. Writes to these Ports do not require XBARE = '1'.*

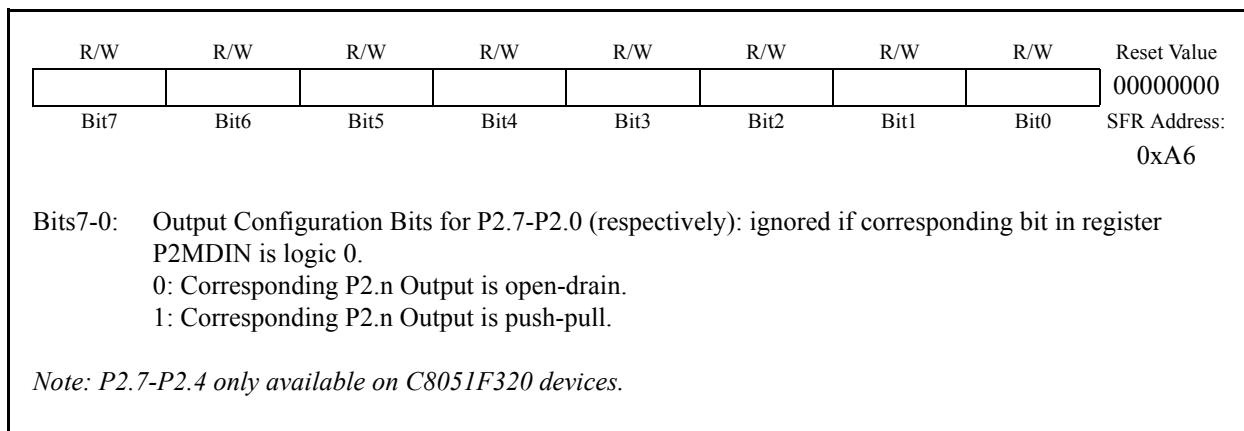
**Figure 14.16. P2MDIN: Port2 Input Mode Register**

R/W	R/W	R/W	R/W	R/W	R/W	R/W	R/W	Reset Value
								11111111
Bit7	Bit6	Bit5	Bit4	Bit3	Bit2	Bit1	Bit0	SFR Address:
								0xF3

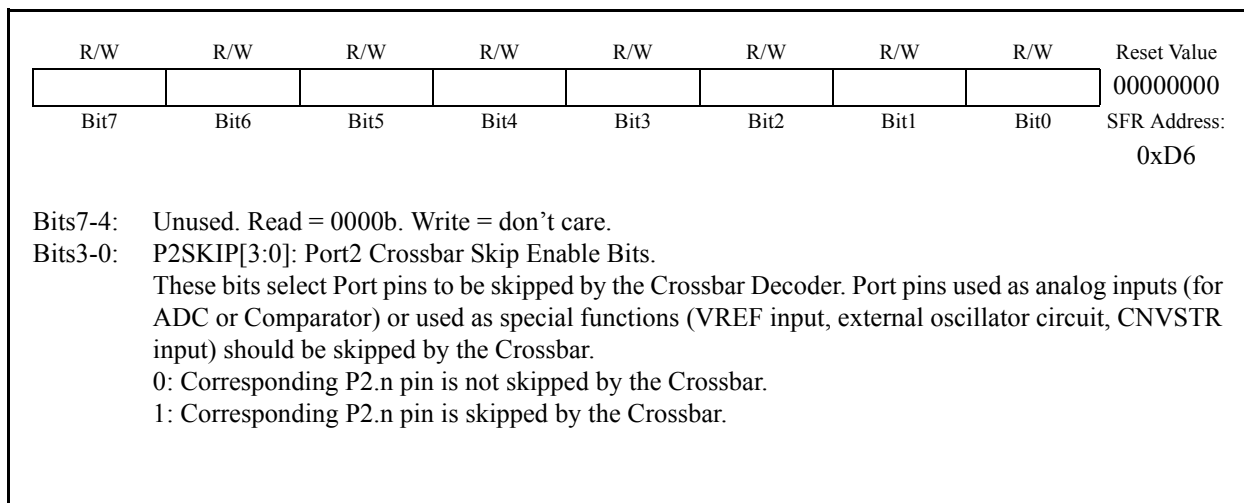
Bits7-0: Analog Input Configuration Bits for P2.7-P2.0 (respectively).  
 Port pins configured as analog inputs have their weak pull-up, digital driver, and digital receiver disabled.  
 0: Corresponding P2.n pin is configured as an analog input.  
 1: Corresponding P2.n pin is not configured as an analog input.

*Note: P2.7-P2.4 only available on C8051F320 devices.*

**Figure 14.17. P2MDOUT: Port2 Output Mode Register**



**Figure 14.18. P2SKIP: Port2 Skip Register**



**Figure 14.19. P3: Port3 Register**

R/W	R/W	R/W	R/W	R/W	R/W	R/W	R/W	Reset Value
P3.7	P3.6	P3.5	P3.4	P3.3	P3.2	P3.1	P3.0	11111111
Bit7	Bit6	Bit5	Bit4	Bit3	Bit2	Bit1	Bit0	SFR Address: (bit addressable) 0xB0

Bits7-0: P3.[7:0]  
 Write - Output appears on I/O pins.  
 0: Logic Low Output.  
 1: Logic High Output (high impedance if corresponding P3MDOUT.n bit = 0).  
 Read - Always reads '0' if selected as analog input in register P3MDIN. Directly reads Port pin when configured as digital input.  
 0: P3.n pin is logic low.  
 1: P3.n pin is logic high.

**Figure 14.20. P3MDIN: Port3 Input Mode Register**

R/W	R/W	R/W	R/W	R/W	R/W	R/W	R/W	Reset Value
								00000001
Bit7	Bit6	Bit5	Bit4	Bit3	Bit2	Bit1	Bit0	SFR Address: 0xF4

Bits7-1: UNUSED. Read = 0000000b; Write = don't care.  
 Bit0: Analog Input Configuration Bit for P3.0.  
 Port pins configured as analog inputs have their weak pull-up, digital driver, and digital receiver disabled.  
 0: Corresponding P3.n pin is configured as an analog input.  
 1: Corresponding P3.n pin is not configured as an analog input.

**Figure 14.21. P3MDOUT: Port3 Output Mode Register**

R/W	R/W	R/W	R/W	R/W	R/W	R/W	R/W	Reset Value
-	-	-						00000000
Bit7	Bit6	Bit5	Bit4	Bit3	Bit2	Bit1	Bit0	SFR Address: 0xA7

Bits7-1: UNUSED. Read = 0000000b; Write = don't care.  
 Bit0: Output Configuration Bit for P3.0; ignored if corresponding bit in register P3MDIN is logic 0.  
 0: Corresponding P3.n Output is open-drain.  
 1: Corresponding P3.n Output is push-pull.

**Table 14.1. Port I/O DC Electrical Characteristics**

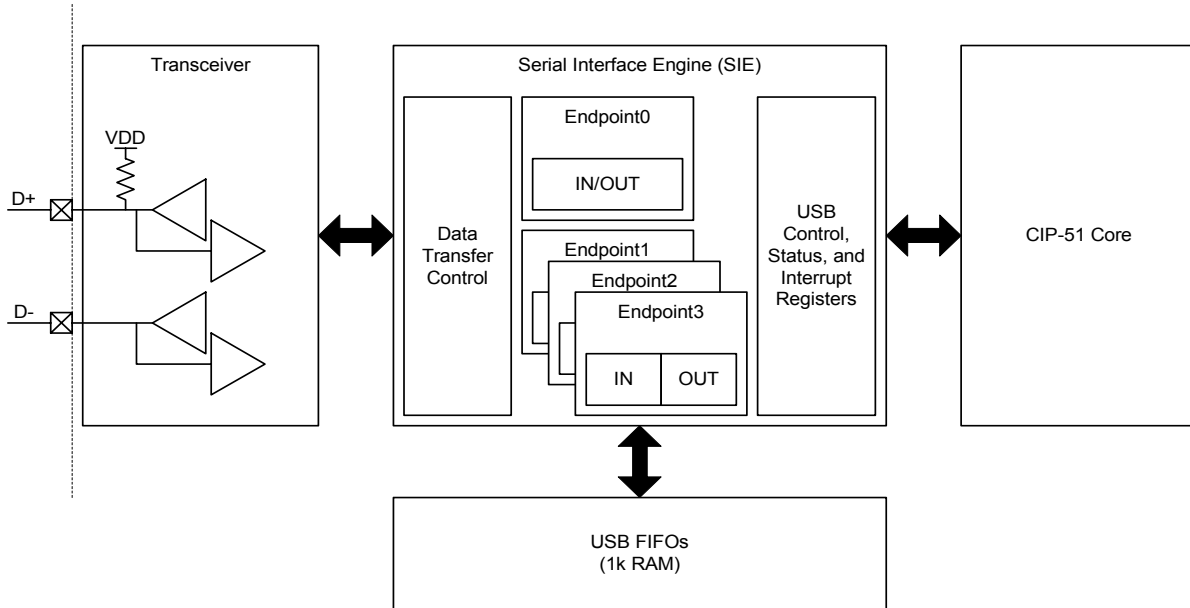
VDD = 2.7 to 3.6V, -40°C to +85°C unless otherwise specified

PARAMETERS	CONDITIONS	MIN	TYP	MAX	UNITS
Output High Voltage	$I_{OH} = -3\text{mA}$ , Port I/O push-pull $I_{OH} = -10\mu\text{A}$ , Port I/O push-pull $I_{OH} = -10\text{mA}$ , Port I/O push-pull	VDD-0.7 VDD-0.1	VDD-0.8		V
Output Low Voltage	$I_{OL} = 8.5\text{mA}$ $I_{OL} = 10\mu\text{A}$ $I_{OL} = 25\text{mA}$		1.0	0.6 0.1	V
Input High Voltage		2.0			V
Input Low Voltage				0.8	V
Input Leakage Current	Weak Pull-up Off Weak Pull-up On, $V_{IN} = 0\text{V}$		25	$\pm 1$ 50	$\mu\text{A}$

## 15. UNIVERSAL SERIAL BUS CONTROLLER (USB0)

C8051F320/1 devices include a complete Full/Low Speed USB function for USB peripheral implementations†. The USB Function Controller (USB0) consists of a Serial Interface Engine (SIE), USB Transceiver (including matching resistors and configurable pull-up resistors), 1k FIFO block, and clock recovery mechanism for crystal-less operation. No external components are required. The USB Function Controller and Transceiver is Universal Serial Bus Specification 2.0 compliant.

**Figure 15.1. USB0 Block Diagram**



**Important Note:** This document assumes a comprehensive understanding of the USB Protocol. Terms and abbreviations used in this document are defined in the USB Specification. We encourage you to review the latest version of the USB Specification before proceeding.

† The C8051F320/1 cannot be used as a USB Host device.

## 15.1. Endpoint Addressing

A total of eight endpoint pipes are available. The control endpoint (Endpoint0) always functions as a bi-directional IN/OUT endpoint. The other endpoints are implemented as three pairs of IN/OUT endpoint pipes:

**Table 15.1. Endpoint Addressing Scheme**

Endpoint	Associated Pipes	USB Protocol Address
Endpoint0	Endpoint0 IN	0x00
	Endpoint0 OUT	0x00
Endpoint1	Endpoint1 IN	0x81
	Endpoint1 OUT	0x01
Endpoint2	Endpoint2 IN	0x82
	Endpoint2 OUT	0x02
Endpoint3	Endpoint3 IN	0x83
	Endpoint3 OUT	0x03

## 15.2. USB Transceiver

The USB Transceiver is configured via the USB0XCN register shown in Figure 15.2. This configuration includes Transceiver enable/disable, pull-up resistor enable/disable, and device speed selection (Full or Low Speed). When bit SPEED = '1', USB0 operates as a Full Speed USB function, and the on-chip pull-up resistor (if enabled) appears on the D+ pin. When bit SPEED = '0', USB0 operates as a Low Speed USB function, and the on-chip pull-up resistor (if enabled) appears on the D- pin. Bits4-0 of register USB0XCN can be used for Transceiver testing as described in Figure 15.2. The pull-up resistor is enabled only when VBUS is present (see [Section "8.2. VBUS Detection" on page 69](#) for details on VBUS detection).

**Important Note: The USB clock should be active before the Transceiver is enabled.**



**Figure 15.2. USB0XCN: USB0 Transceiver Control**

R/W	R/W	R/W	R/W	R/W	R	R	R	Reset Value
PREN	PHYEN	SPEED	PHYTST1	PHYTST0	DFREC	Dp	Dn	00000000
Bit7	Bit6	Bit5	Bit4	Bit3	Bit2	Bit1	Bit0	SFR Address: 0xD7

Bit7: PREN: Internal Pull-up Resistor Enable  
The location of the pull-up resistor (D+ or D-) is determined by the SPEED bit.  
0: Internal pull-up resistor disabled (device effectively detached from the USB network).  
1: Internal pull-up resistor enabled when VBUS is present (device attached to the USB network).

Bit6: PHYEN: Physical Layer Enable  
This bit enables/disables the USB0 physical layer transceiver.  
0: Transceiver disabled (suspend).  
1: Transceiver enabled (normal).

Bit5: SPEED: USB0 Speed Select  
This bit selects the USB0 speed.  
0: USB0 operates as a Low Speed device. If enabled, the internal pull-up resistor appears on the D-line.  
1: USB0 operates as a Full Speed device. If enabled, the internal pull-up resistor appears on the D+ line.

Bits4-3: PHYTST1-0: Physical Layer Test  
These bits can be used to test the USB0 transceiver.

PHYTST[1:0]	Mode	D+	D-
00b	Mode 0: Normal (non-test mode)	X	X
01b	Mode 1: Differential '1' Forced	1	0
10b	Mode 2: Differential '0' Forced	0	1
11b	Mode 3: Single-Ended '0' Forced	0	0

Bit2: DFREC: Differential Receiver  
The state of this bit indicates the current differential value present on the D+ and D- lines when PHYEN = '1'.  
0: Differential '0' signaling on the bus.  
1: Differential '1' signaling on the bus.

Bit1: Dp: D+ Signal Status  
This bit indicates the current logic level of the D+ pin.  
0: D+ signal currently at logic 0.  
1: D+ signal currently at logic 1.

Bit0: Dn: D- Signal Status  
This bit indicates the current logic level of the D- pin.  
0: D- signal currently at logic 0.  
1: D- signal currently at logic 1.

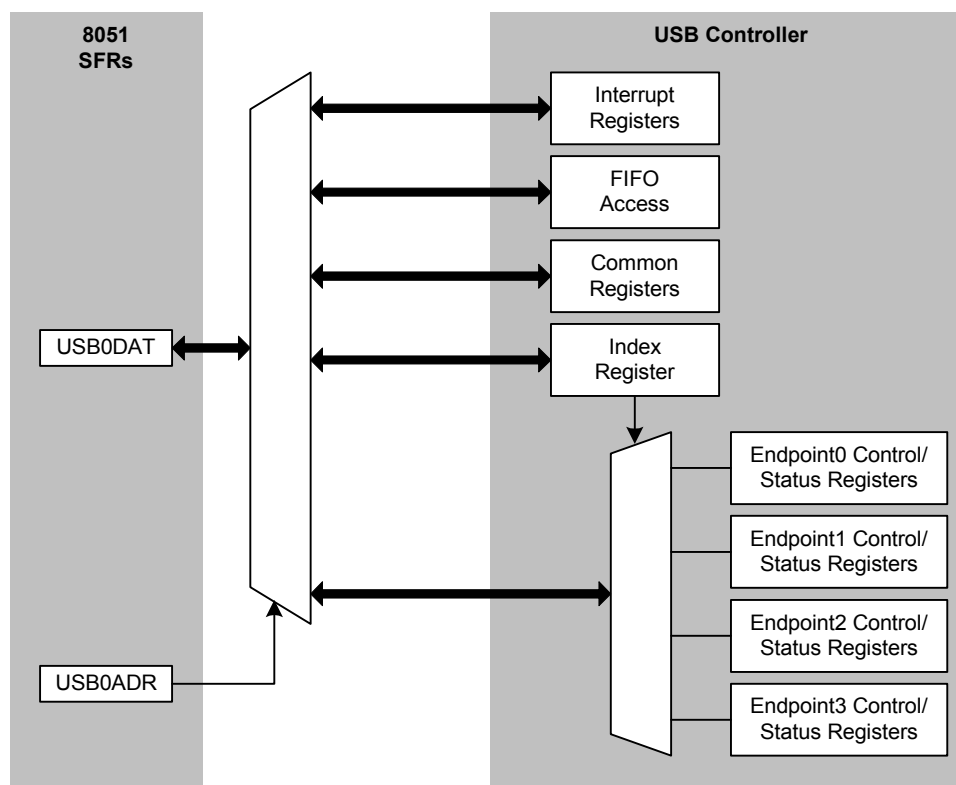
## 15.3. USB Register Access

The USB0 controller registers listed in Table 15.2 are accessed through two SFRs: USB0 Address (USB0ADR) and USB0 Data (USB0DAT). The USB0ADR register selects which USB register is targeted by reads/writes of the USB0DAT register. See Figure 15.3.

Endpoint control/status registers are accessed by first writing the USB register INDEX with the target endpoint number. Once the target endpoint number is written to the INDEX register, the control/status registers associated with the target endpoint may be accessed. See the “Indexed Registers” section of Table 15.2 for a list of endpoint control/status registers.

**Important Note: The USB clock must be active when accessing USB registers.**

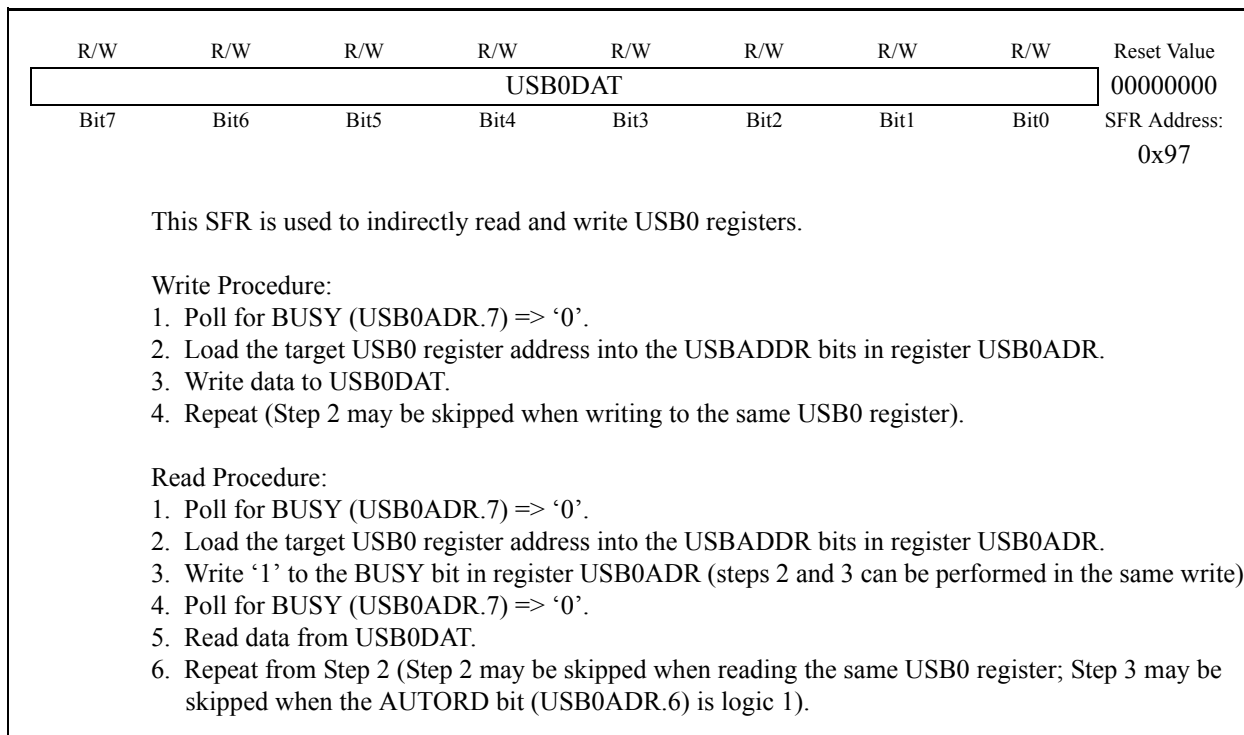
**Figure 15.3. USB0 Register Access Scheme**



**Figure 15.4. USB0ADR: USB0 Indirect Address Register**

R/W	R/W	R/W	R/W	R/W	R/W	R/W	R/W	Reset Value
BUSY	AUTORD	USBADDR						00000000
Bit7	Bit6	Bit5	Bit4	Bit3	Bit2	Bit1	Bit0	SFR Address: 0x96
<p><b>Bits7:</b>     <b>BUSY: USB0 Register Read Busy Flag</b>  This bit is used during indirect USB0 register accesses. Software should write ‘1’ to this bit to initiate a read of the USB0 register targeted by the USBADDR bits (USB0ADR.[5-0]). The target address and BUSY bit may be written in the same write to USB0ADR. After BUSY is set to ‘1’, hardware will clear BUSY when the targeted register data is ready in the USB0DAT register. Software should check BUSY for ‘0’ before writing to USB0DAT.  Write:  0: No effect.  1: A USB0 indirect register read is initiated at the address specified by the USBADDR bits.  Read:  0: USB0DAT register data is valid.  1: USB0 is busy accessing an indirect register; USB0DAT register data is invalid.</p> <p><b>Bit6:</b>     <b>AUTORD: USB0 Register Auto-read Flag</b>  This bit is used for block FIFO reads.  0: BUSY must be written manually for each USB0 indirect register read.  1: The next indirect register read will automatically be initiated when software reads USB0DAT (USBADDR bits will not be changed).</p> <p><b>Bits5-0:</b>   <b>USBADDR: USB0 Indirect Register Address</b>  These bits hold a 6-bit address used to indirectly access the USB0 core registers. Table 15.2 lists the USB0 core registers and their indirect addresses. Reads and writes to USB0DAT will target the register indicated by the USBADDR bits.</p>								

**Figure 15.5. USB0DAT: USB0 Data Register**



**Figure 15.6. INDEX: USB0 Endpoint Index (USB Register)**

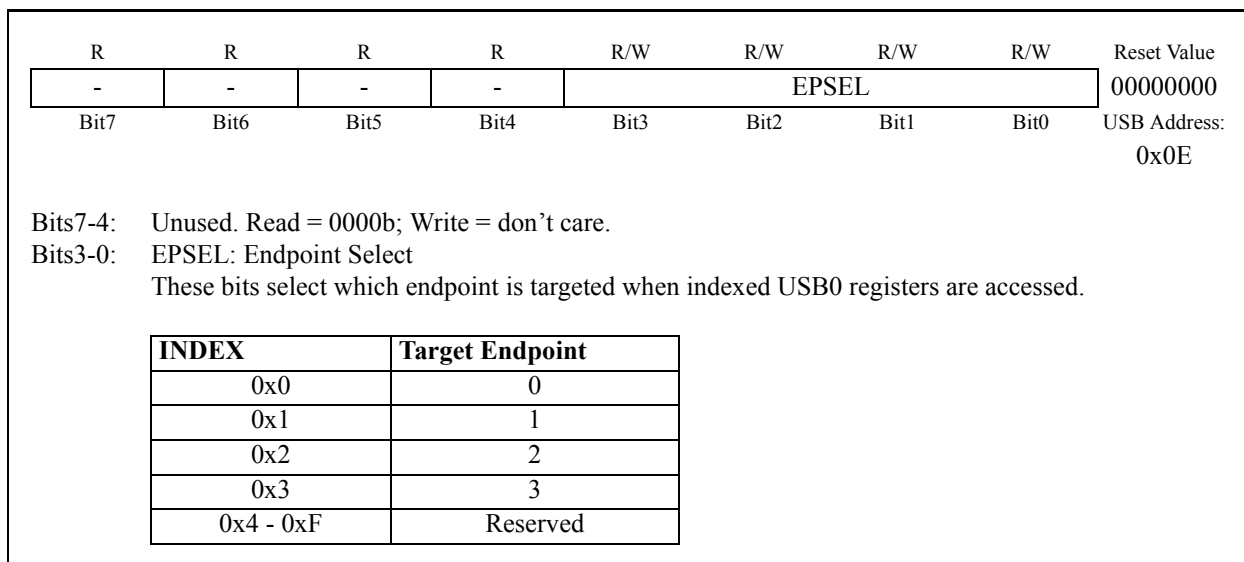


Table 15.2. USB0 Controller Registers

USB Register Name	USB Register Address	Description	Page Number
<b>Interrupt Registers</b>			
INIINT	0x02	Endpoint0 and Endpoints1-3 IN Interrupt Flags	157
OUTIINT	0x04	Endpoints1-3 OUT Interrupt Flags	158
CMINT	0x06	Common USB Interrupt Flags	159
INIIE	0x07	Endpoint0 and Endpoints1-3 IN Interrupt Enables	160
OUTIIE	0x09	Endpoints1-3 OUT Interrupt Enables	160
CMIE	0x0B	Common USB Interrupt Enables	161
<b>Common Registers</b>			
FADDR	0x00	Function Address	153
POWER	0x01	Power Management	155
FRAMEL	0x0C	Frame Number Low Byte	156
FRAMEH	0x0D	Frame Number High Byte	156
INDEX	0x0E	Endpoint Index Selection	148
CLKREC	0x0F	Clock Recovery Control	150
FIFO <sub>n</sub>	0x20-0x23	Endpoints0-3 FIFOs	152
<b>Indexed Registers</b>			
E0CSR	0x11	Endpoint0 Control / Status	164
EINCSRL		Endpoint IN Control / Status Low Byte	168
EINCSRH	0x12	Endpoint IN Control / Status High Byte	169
EOUTCSRL	0x14	Endpoint OUT Control / Status Low Byte	171
EOUTCSRH	0x15	Endpoint OUT Control / Status High Byte	172
E0CNT	0x16	Number of Received Bytes in Endpoint0 FIFO	165
EOUTCNTL		Endpoint OUT Packet Count Low Byte	172
EOUTCNTH	0x17	Endpoint OUT Packet Count High Byte	172

## 15.4. USB Clock Configuration

USB0 is capable of communication as a Full or Low Speed USB function. Communication speed is selected via the SPEED bit in SFR USB0XCN. When operating as a Low Speed function, the USB0 clock must be 6 MHz. When operating as a Full Speed function, the USB0 clock must be 48 MHz. Clock options are described in **Section “13. Oscillators” on page 117**. The USB0 clock is selected via SFR CLKSEL (see Figure 13.6 on Page 125).

Clock Recovery circuitry uses the incoming USB data stream to adjust the internal oscillator; this allows the internal oscillator (and 4x Clock Multiplier) to meet the requirements for USB clock tolerance. Clock Recovery should be used in the following configurations:

Communication Speed	USB Clock	4x Clock Multiplier Input
Full Speed	4x Clock Multiplier	Internal Oscillator
Low Speed	Internal Oscillator / 2	N/A

When operating USB0 as a Low Speed function with Clock Recovery, software must write ‘1’ to the CRLOW bit to enable Low Speed Clock Recovery. Clock Recovery is typically not necessary in Low Speed mode.

Single Step Mode can be used to help the Clock Recovery circuitry to lock when high noise levels are present on the USB network. This mode is not required (or recommended) in typical USB environments.

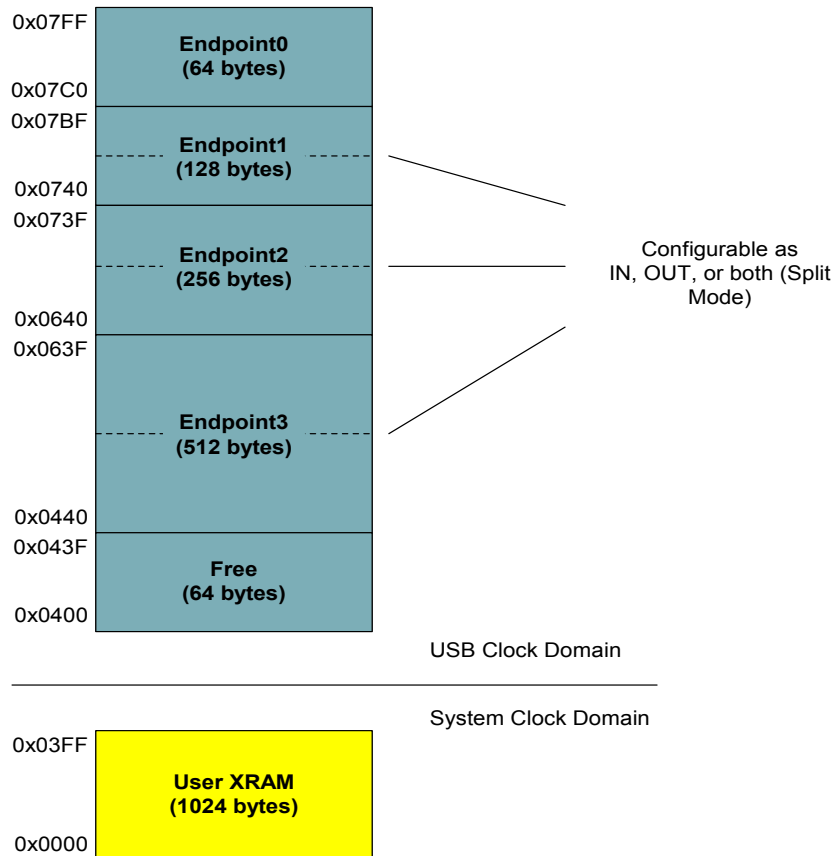
**Figure 15.7. CLKREC: Clock Recovery Control (USB Register)**

R/W	R/W	R/W	R/W	R/W	R/W	R/W	R/W	Reset Value
CRE	CRSSEN	CRLOW	Reserved					00001001
Bit7	Bit6	Bit5	Bit4	Bit3	Bit2	Bit1	Bit0	USB Address: 0x0F
Bit7:	CRE: Clock Recovery Enable. This bit enables/disables the USB clock recovery feature. 0: Clock recovery disabled. 1: Clock recovery enabled.							
Bit6:	CRSSEN: Clock Recovery Single Step. This bit forces the oscillator calibration into ‘single-step’ mode during clock recovery. 0: Normal calibration mode. 1: Single step mode.							
Bit5:	CRLOW: Low Speed Clock Recovery Mode. This bit must be set to ‘1’ if clock recovery is used when operating as a Low Speed USB device. 0: Full Speed Mode. 1: Low Speed Mode.							
Bits4-0:	Reserved. Read = Variable. Must Write = 1001b.							

## 15.5. FIFO Management

1024 bytes of on-chip XRAM are used as FIFO space for USB0. This FIFO space is split between Endpoints0-3 as shown in Figure 15.8. FIFO space allocated for Endpoints1-3 is configurable as IN, OUT, or both (Split Mode: half IN, half OUT).

**Figure 15.8. USB FIFO Allocation**



### 15.5.1. FIFO Split Mode

The FIFO space for Endpoints1-3 can be split such that the upper half of the FIFO space is used by the IN endpoint, and the lower half is used by the OUT endpoint. For example: if the Endpoint3 FIFO is configured for Split Mode, the upper 256 bytes (0x0540 to 0x063F) are used by Endpoint3 IN and the lower 256 bytes (0x0440 to 0x053F) are used by Endpoint3 OUT.

If an endpoint FIFO is not configured for Split Mode, that endpoint IN/OUT pair's FIFOs are combined to form a single IN *or* OUT FIFO. In this case only one direction of the endpoint IN/OUT pair may be used at a time. The endpoint direction (IN/OUT) is determined by the DIRSEL bit in the corresponding endpoint's EINCSRH register (see Figure 15.23).

### 15.5.2. FIFO Double Buffering

FIFO slots for Endpoints1-3 can be configured for double-buffered mode. In this mode, the maximum packet size is halved and the FIFO may contain two packets at a time. This mode is available for Endpoints1-3. When an endpoint is configured for Split Mode, double buffering may be enabled for the IN Endpoint and/or the OUT endpoint. When

Split Mode is not enabled, double-buffering may be enabled for the entire endpoint FIFO. See Table 15.3 for a list of maximum packet sizes for each FIFO configuration.

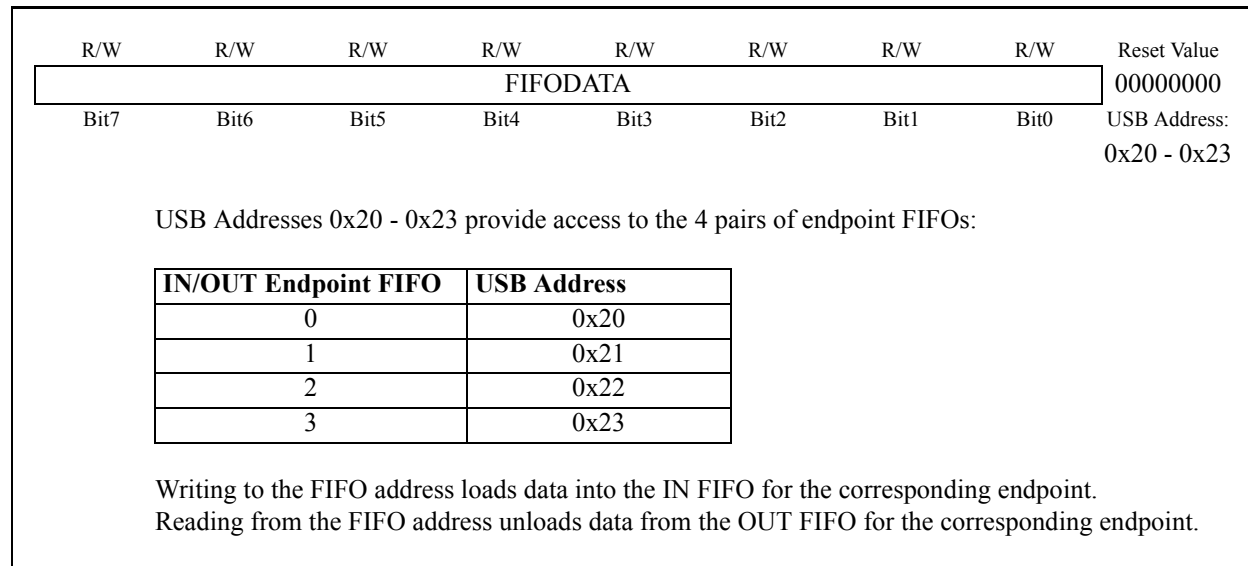
**Table 15.3. FIFO Configurations**

Endpoint Number	Split Mode Enabled?	Maximum IN Packet Size (Double Buffer Disabled / Enabled)	Maximum OUT Packet Size (Double Buffer Disabled / Enabled)
0	N/A	64	
1	N	128 / 64	
	Y	64 / 32	64 / 32
2	N	256 / 128	
	Y	128 / 64	128 / 64
3	N	512 / 256	
	Y	256 / 128	256 / 128

### 15.5.3. FIFO Access

Each endpoint FIFO is accessed through a corresponding FIFOn register. A read of an endpoint FIFOn register unloads one byte from the FIFO; a write of an endpoint FIFOn register loads one byte into the endpoint FIFO. When an endpoint FIFO is configured for Split Mode, a read of the endpoint FIFOn register unloads one byte from the OUT endpoint FIFO; a write of the endpoint FIFOn register loads one byte into the IN endpoint FIFO.

**Figure 15.9. FIFOn: USB0 Endpoint FIFO Access (USB Registers)**





## 15.6. Function Addressing

The FADDR register holds the current USB0 function address. Software should write the host-assigned 7-bit function address to the FADDR register when received as part of a SET\_ADDRESS command. A new address written to FADDR will not take effect (USB0 will not respond to the new address) until the end of the current transfer (typically following the status phase of the SET\_ADDRESS command transfer). The UPDATE bit (FADDR.7) is set to '1' by hardware when software writes a new address to the FADDR register. Hardware clears the UPDATE bit when the new address takes effect as described above.

**Figure 15.10. FADDR: USB0 Function Address (USB Register)**

R	R/W	R/W	R/W	R/W	R/W	R/W	R/W	Reset Value
Update	Function Address							00000000
Bit7	Bit6	Bit5	Bit4	Bit3	Bit2	Bit1	Bit0	USB Address: 0x00
Bit7:	Update: Function Address Update Set to '1' when software writes the FADDR register. USB0 clears this bit to '0' when the new address takes effect. 0: The last address written to FADDR is in effect. 1: The last address written to FADDR is not yet in effect.							
Bits6-0:	Function Address Holds the 7-bit function address for USB0. This address should be written by software when the SET_ADDRESS standard device request is received on Endpoint0. The new address takes effect when the device request completes.							

## 15.7. Function Configuration and Control

The USB register POWER (Figure 15.11) is used to configure and control USB0 at the device level (enable/disable, Reset/Suspend/Resume handling, etc.).

**USB Reset:** The USBRST bit (POWER.3) is set to '1' by hardware when Reset signaling is detected on the bus. Upon this detection, the following occur:

1. The USB0 Address is reset (FADDR = 0x00).
2. Endpoint FIFOs are flushed.
3. Control/status registers are reset to 0x00 (E0CSR, EINCSRL, EINCSRH, EOUTCSRL, EOUTCSRH).
4. USB register INDEX is reset to 0x00.
5. All USB interrupts (excluding the Suspend interrupt) are enabled and their corresponding flags cleared.
6. A USB Reset interrupt is generated if enabled.

Writing a '1' to the USBRST bit will generate an asynchronous USB0 reset. All USB registers are reset to their default values following this asynchronous reset.

**Suspend Mode:** With Suspend Detection enabled (SUSEN = '1'), USB0 will enter Suspend Mode when Suspend signaling is detected on the bus. An interrupt will be generated if enabled (SUSINTE = '1'). The Suspend Interrupt Service Routine (ISR) should perform application-specific configuration tasks such as disabling appropriate peripherals and/or configuring clock sources for low power modes. See **Section "13. Oscillators" on page 117** for more details on internal oscillator configuration, including the Suspend mode feature of the internal oscillator.

USB0 exits Suspend mode when any of the following occur: (1) Resume signaling is detected or generated, (2) Reset signaling is detected, or (3) a device or USB reset occurs. If suspended, the internal oscillator will exit Suspend mode upon any of the above listed events.

**Resume Signaling:** USB0 will exit Suspend mode if Resume signaling is detected on the bus. A Resume interrupt will be generated upon detection if enabled (RESINTE = '1'). Software may force a Remote Wakeup by writing '1' to the RESUME bit (POWER.2). When forcing a Remote Wakeup, software should write RESUME = '0' to end Resume signaling 10-15 ms after the Remote Wakeup is initiated (RESUME = '1').

**ISO Update:** When software writes '1' to the ISOUP bit (POWER.7), the ISO Update function is enabled. With ISO Update enabled, new packets written to an ISO IN endpoint will not be transmitted until a new Start-Of-Frame (SOF) is received. If the ISO IN endpoint receives an IN token before a SOF, USB0 will transmit a zero-length packet. When ISOUP = '1', ISO Update is enabled for all ISO endpoints.

**USB Enable:** USB0 is disabled following a Power-On-Reset (POR). USB0 is enabled by clearing the USBINH bit (POWER.4). Once written to '0', the USBINH can only be set to '1' by one of the following: (1) a Power-On-Reset (POR), or (2) an asynchronous USB0 reset generated by writing '1' to the USBRST bit (POWER.3).

Software should perform all USB0 configuration before enabling USB0. The configuration sequence should be performed as follows:

- Step 1. Select and enable the USB clock source.
- Step 2. Reset USB0 by writing USBRST = '1'.
- Step 3. Configure and enable the USB Transceiver.
- Step 4. Perform any USB0 function configuration (interrupts, Suspend detect).
- Step 5. Enable USB0 by writing USBINH = '0'.

**Figure 15.11. POWER: USB0 Power (USB Register)**

R/W	R/W	R/W	R/W	R/W	R/W	R	R/W	Reset Value
ISOUD	-	-	USBINH	USBRST	RESUME	SUSMD	SUSEN	00010000
Bit7	Bit6	Bit5	Bit4	Bit3	Bit2	Bit1	Bit0	USB Address: 0x01

Bit7: ISOUD: ISO Update  
This bit affects all IN Isochronous endpoints.  
0: When software writes INPRDY = '1', USB0 will send the packet when the next IN token is received.  
1: When software writes INPRDY = '1', USB0 will wait for a SOF token before sending the packet. If an IN token is received before a SOF token, USB0 will send a zero-length data packet.

Bits6-5: Unused. Read = 00b. Write = don't care.

Bit4: USBINH: USB0 Inhibit  
This bit is set to '1' following a power-on reset (POR) or an asynchronous USB0 reset (see Bit3: RESET). Software should clear this bit after all USB0 and transceiver initialization is complete. Software cannot set this bit to '1'.  
0: USB0 enabled.  
1: USB0 inhibited. All USB traffic is ignored.

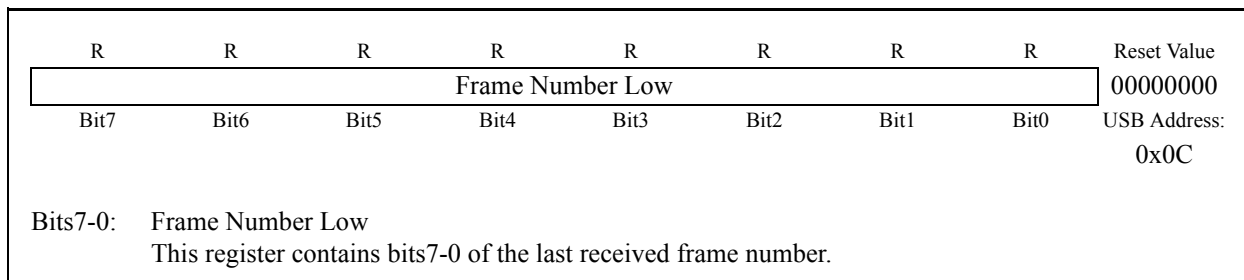
Bit3: USBRST: Reset Detect  
Writing '1' to this bit forces an asynchronous USB0 reset. Reading this bit provides bus reset status information.  
Read:  
0: Reset signaling is not present on the bus.  
1: Reset signaling detected on the bus.

Bit2: RESUME: Force Resume  
Software can force resume signaling on the bus to wake USB0 from suspend mode. Writing a '1' to this bit while in Suspend mode (SUSMD = '1') forces USB0 to generate Resume signaling on the bus (a remote Wakeup event). Software should write RESUME = '0' after 10 ms to 15 ms to end the Resume signaling. An interrupt is generated, and hardware clears SUSMD, when software writes RESUME = '0'.

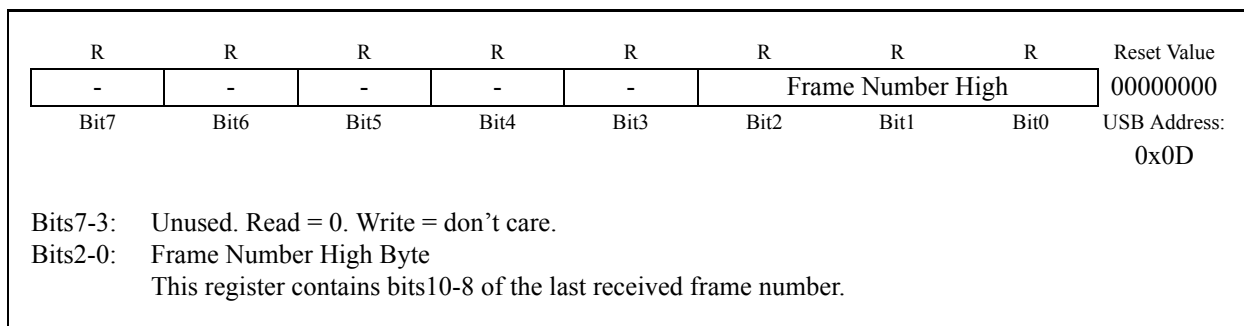
Bit1: SUSMD: Suspend Mode  
Set to '1' by hardware when USB0 enters suspend mode. Cleared by hardware when software writes RESUME = '0' (following a remote wakeup) or reads the CMINT register after detection of Resume signaling on the bus.  
0: USB0 not in suspend mode.  
1: USB0 in suspend mode.

Bit0: SUSEN: Suspend Detection Enable  
0: Suspend detection disabled. USB0 will ignore suspend signaling on the bus.  
1: Suspend detection enabled. USB0 will enter suspend mode if it detects suspend signaling on the bus.

**Figure 15.12. FRAMEL: USB0 Frame Number Low (USB Register)**



**Figure 15.13. FRAMEH: USB0 Frame Number High (USB Register)**



## 15.8. Interrupts

The read-only USB0 interrupt flags are located in the USB registers shown in Figure 15.14 through Figure 15.16. The associated interrupt enable bits are located in the USB registers shown in Figure 15.17 through Figure 15.19. A USB0 interrupt is generated when any of the USB interrupt flags is set to ‘1’. The USB0 interrupt is enabled via the EIE1 SFR (see **Section “9.3. Interrupt Handler” on page 87**).

**Important Note: Reading a USB interrupt flag register resets all flags in that register to ‘0’.**

**Figure 15.14. IN1INT: USB0 IN Endpoint Interrupt (USB Register)**

R	R	R	R	R	R	R	R	Reset Value
-	-	-	-	IN3	IN2	IN1	EP0	00000000
Bit7	Bit6	Bit5	Bit4	Bit3	Bit2	Bit1	Bit0	USB Address: 0x02

Bits7-4: Unused. Read = 0000b. Write = don’t care.

Bit3: IN3: IN Endpoint 3 Interrupt-pending Flag  
This bit is cleared when software reads the IN1INT register.  
0: IN Endpoint 3 interrupt inactive.  
1: IN Endpoint 3 interrupt active.

Bit2: IN2: IN Endpoint 2 Interrupt-pending Flag  
This bit is cleared when software reads the IN1INT register.  
0: IN Endpoint 2 interrupt inactive.  
1: IN Endpoint 2 interrupt active.

Bit1: IN1: IN Endpoint 1 Interrupt-pending Flag  
This bit is cleared when software reads the IN1INT register.  
0: IN Endpoint 1 interrupt inactive.  
1: IN Endpoint 1 interrupt active.

Bit0: EP0: Endpoint 0 Interrupt-pending Flag  
This bit is cleared when software reads the IN1INT register.  
0: Endpoint 0 interrupt inactive.  
1: Endpoint 0 interrupt active.

**Figure 15.15. OUT1INT: USB0 Out Endpoint Interrupt (USB Register)**

R	R	R	R	R	R	R	R	Reset Value
-	-	-	-	OUT3	OUT2	OUT1	-	00000000
Bit7	Bit6	Bit5	Bit4	Bit3	Bit2	Bit1	Bit0	USB Address: 0x04

Bits7-4: Unused. Read = 0000b. Write = don't care.  
 Bit3: OUT3: OUT Endpoint 3 Interrupt-pending Flag  
 This bit is cleared when software reads the OUT1INT register.  
 0: OUT Endpoint 3 interrupt inactive.  
 1: OUT Endpoint 3 interrupt active.  
 Bit2: OUT2: OUT Endpoint 2 Interrupt-pending Flag  
 This bit is cleared when software reads the OUT1INT register.  
 0: OUT Endpoint 2 interrupt inactive.  
 1: OUT Endpoint 2 interrupt active.  
 Bit1: OUT1: OUT Endpoint 1 Interrupt-pending Flag  
 This bit is cleared when software reads the OUT1INT register.  
 0: OUT Endpoint 1 interrupt inactive.  
 1: OUT Endpoint 1 interrupt active.  
 Bit0: Unused. Read = 0; Write = don't care.

**Figure 15.16. CMINT: USB0 Common Interrupt (USB Register)**

R	R	R	R	R	R	R	R	Reset Value
-	-	-	-	SOF	RSTINT	RSUINT	SUSINT	00000000
Bit7	Bit6	Bit5	Bit4	Bit3	Bit2	Bit1	Bit0	USB Address: 0x06

Bits7-4: Unused. Read = 0000b; Write = don't care.

Bit3: SOF: Start of Frame Interrupt  
Set by hardware when a SOF token is received. This interrupt event is synthesized by hardware: an interrupt will be generated when hardware expects to receive a SOF event, even if the actual SOF signal is missed or corrupted.  
This bit is cleared when software reads the CMINT register.  
0: SOF interrupt inactive.  
1: SOF interrupt active.

Bit2: RSTINT: Reset Interrupt-pending Flag  
Set by hardware when Reset signaling is detected on the bus.  
This bit is cleared when software reads the CMINT register.  
0: Reset interrupt inactive.  
1: Reset interrupt active.

Bit1: RSUINT: Resume Interrupt-pending Flag  
Set by hardware when Resume signaling is detected on the bus while USB0 is in suspend mode.  
This bit is cleared when software reads the CMINT register.  
0: Resume interrupt inactive.  
1: Resume interrupt active.

Bit0: SUSINT: Suspend Interrupt-pending Flag  
When Suspend detection is enabled (bit SUSEN in register POWER), this bit is set by hardware when Suspend signaling is detected on the bus. This bit is cleared when software reads the CMINT register.  
0: Suspend interrupt inactive.  
1: Suspend interrupt active.

**Figure 15.17. IN1IE: USB0 IN Endpoint Interrupt Enable (USB Register)**

R/W	R/W	R/W	R/W	R/W	R/W	R/W	R/W	Reset Value
-	-	-	-	IN3E	IN2E	IN1E	EP0E	00001111
Bit7	Bit6	Bit5	Bit4	Bit3	Bit2	Bit1	Bit0	USB Address: 0x07

Bits7-4: Unused. Read = 0000b. Write = don't care.  
 Bit3: IN3E: IN Endpoint 3 Interrupt Enable  
 0: IN Endpoint 3 interrupt disabled.  
 1: IN Endpoint 3 interrupt enabled.  
 Bit2: IN2E: IN Endpoint 2 Interrupt Enable  
 0: IN Endpoint 2 interrupt disabled.  
 1: IN Endpoint 2 interrupt enabled.  
 Bit1: IN1E: IN Endpoint 1 Interrupt Enable  
 0: IN Endpoint 1 interrupt disabled.  
 1: IN Endpoint 1 interrupt enabled.  
 Bit0: EP0E: Endpoint 0 Interrupt Enable  
 0: Endpoint 0 interrupt disabled.  
 1: Endpoint 0 interrupt enabled.

**Figure 15.18. OUT1IE: USB0 Out Endpoint Interrupt Enable (USB Register)**

R/W	R/W	R/W	R/W	R/W	R/W	R/W	R/W	Reset Value
-	-	-	-	OUT3E	OUT2E	OUT1E	-	00001110
Bit7	Bit6	Bit5	Bit4	Bit3	Bit2	Bit1	Bit0	USB Address: 0x09

Bits7-4: Unused. Read = 0000b. Write = don't care.  
 Bit3: OUT3E: OUT Endpoint 3 Interrupt Enable  
 0: OUT Endpoint 3 interrupt disabled.  
 1: OUT Endpoint 3 interrupt enabled.  
 Bit2: OUT2E: OUT Endpoint 2 Interrupt Enable  
 0: OUT Endpoint 2 interrupt disabled.  
 1: OUT Endpoint 2 interrupt enabled.  
 Bit1: OUT1E: OUT Endpoint 1 Interrupt Enable  
 0: OUT Endpoint 1 interrupt disabled.  
 1: OUT Endpoint 1 interrupt enabled.  
 Bit0: Unused. Read = 0; Write = don't care.



**Figure 15.19. CMIE: USB0 Common Interrupt Enable (USB Register)**

R/W	R/W	R/W	R/W	R/W	R/W	R/W	R/W	Reset Value
-	-	-	-	SOFE	RSTINTE	RSUINTE	SUSINTE	00000110
Bit7	Bit6	Bit5	Bit4	Bit3	Bit2	Bit1	Bit0	USB Address: 0x0B

Bits7-4: Unused. Read = 0000b; Write = don't care.  
 Bit3: SOFE: Start of Frame Interrupt Enable  
 0: SOF interrupt disabled.  
 1: SOF interrupt enabled.  
 Bit2: RSTINTE: Reset Interrupt Enable  
 0: Reset interrupt disabled.  
 1: Reset interrupt enabled.  
 Bit1: RSUINTE: Resume Interrupt Enable  
 0: Resume interrupt disabled.  
 1: Resume interrupt enabled.  
 Bit0: SUSINTE: Suspend Interrupt Enable  
 0: Suspend interrupt disabled.  
 1: Suspend interrupt enabled.

## 15.9. The Serial Interface Engine

The Serial Interface Engine (SIE) performs all low level USB protocol tasks, interrupting the processor when data has successfully been transmitted or received. When receiving data, the SIE will interrupt the processor when a complete data packet has been received; appropriate handshaking signals are automatically generated by the SIE. When transmitting data, the SIE will interrupt the processor when a complete data packet has been transmitted and the appropriate handshake signal has been received.

The SIE will not interrupt the processor when corrupted/erroneous packets are received.

## 15.10. Endpoint0

Endpoint0 is managed through the USB register E0CSR (Figure 15.20). The INDEX register must be loaded with 0x00 to access the E0CSR register.

An Endpoint0 interrupt is generated when:

1. A data packet (OUT or SETUP) has been received and loaded into the Endpoint0 FIFO. The OPRDY bit (E0CSR.0) is set to '1' by hardware.
2. An IN data packet has successfully been unloaded from the Endpoint0 FIFO and transmitted to the host; INPRDY is reset to '0' by hardware.
3. An IN transaction is completed (this interrupt generated during the status stage of the transaction).
4. Hardware sets the STSTL bit (E0CSR.2) after a control transaction ended due to a protocol violation.
5. Hardware sets the SUEND bit (E0CSR.4) because a control transfer ended before firmware sets the DATAEND bit (E0CSR.3).

The E0CNT register (Figure 15.21) holds the number of received data bytes in the Endpoint0 FIFO.

Hardware will automatically detect protocol errors and send a STALL condition in response. Firmware may force a STALL condition to abort the current transfer. When a STALL condition is generated, the STSTL bit will be set to '1' and an interrupt generated. The following conditions will cause hardware to generate a STALL condition:

1. The host sends an OUT token during a OUT data phase after the DATAEND bit has been set to '1'.
2. The host sends an IN token during an IN data phase after the DATAEND bit has been set to '1'.
3. The host sends a packet that exceeds the maximum packet size for Endpoint0.
4. The host sends a non-zero length DATA1 packet during the status phase of an IN transaction.

Firmware sets the SDSTL bit (E0CSR.5) to '1'.

## 15.10.1.Endpoint0 SETUP Transactions

All control transfers must begin with a SETUP packet. SETUP packets are similar to OUT packets, containing an 8-byte data field sent by the host. Any SETUP packet containing a command field of anything other than 8 bytes will be automatically rejected by USB0. An Endpoint0 interrupt is generated when the data from a SETUP packet is loaded into the Endpoint0 FIFO. Software should unload the command from the Endpoint0 FIFO, decode the command, perform any necessary tasks, and set the SOPRDY bit to indicate that it has serviced the OUT packet.

## 15.10.2.Endpoint0 IN Transactions

When a SETUP request is received that requires USB0 to transmit data to the host, one or more IN requests will be sent by the host. For the first IN transaction, firmware should load an IN packet into the Endpoint0 FIFO, and set the INPRDY bit (E0CSR.1). An interrupt will be generated when an IN packet is transmitted successfully. Note that no interrupt will be generated if an IN request is received before firmware has loaded a packet into the Endpoint0 FIFO. If the requested data exceeds the maximum packet size for Endpoint0 (as reported to the host), the data should be split into multiple packets; each packet should be of the maximum packet size excluding the last (residual) packet. If the requested data is an integer multiple of the maximum packet size for Endpoint0, the last data packet should be a zero-length packet signaling the end of the transfer. Firmware should set the DATAEND bit to '1' after loading into the Endpoint0 FIFO the last data packet for a transfer.

Upon reception of the first IN token for a particular control transfer, Endpoint0 is said to be in Transmit Mode. In this mode, only IN tokens should be sent by the host to Endpoint0. The SUEND bit (E0CSR.4) is set to '1' if a SETUP or OUT token is received while Endpoint0 is in Transmit Mode.

Endpoint0 will remain in Transmit Mode until any of the following occur:

1. USB0 receives an Endpoint0 SETUP or OUT token.
2. Firmware sends a packet less than the maximum Endpoint0 packet size.
3. Firmware sends a zero-length packet.

Firmware should set the DATAEND bit (E0CSR.3) to '1' when performing (2) and (3) above.

The SIE will transmit a NAK in response to an IN token if there is no packet ready in the IN FIFO (INPRDY = '0').

---

### 15.10.3.Endpoint0 OUT Transactions

When a SETUP request is received that requires the host to transmit data to USB0, one or more OUT requests will be sent by the host. When an OUT packet is successfully received by USB0, hardware will set the OPRDY bit (E0CSR.0) to '1' and generate an Endpoint0 interrupt. Following this interrupt, firmware should unload the OUT packet from the Endpoint0 FIFO and set the SOPRDY bit (E0CSR.6) to '1'.

If the amount of data required for the transfer exceeds the maximum packet size for Endpoint0, the data will be split into multiple packets. If the requested data is an integer multiple of the maximum packet size for Endpoint0 (as reported to the host), the host will send a zero-length data packet signaling the end of the transfer.

Upon reception of the first OUT token for a particular control transfer, Endpoint0 is said to be in Receive Mode. In this mode, only OUT tokens should be sent by the host to Endpoint0. The SUEND bit (E0CSR.4) is set to '1' if a SETUP or IN token is received while Endpoint0 is in Receive Mode.

Endpoint0 will remain in Receive mode until:

1. The SIE receives a SETUP or IN token.
2. The host sends a packet less than the maximum Endpoint0 packet size.
3. The host sends a zero-length packet.

Firmware should set the DATAEND bit (E0CSR.3) to '1' when the expected amount of data has been received. The SIE will transmit a STALL condition if the host sends an OUT packet after the DATAEND bit has been set by firmware. An interrupt will be generated with the STSTL bit (E0CSR.2) set to '1' after the STALL is transmitted.

**Figure 15.20. E0CSR: USB0 Endpoint0 Control (USB Register)**

	R/W	R/W	R/W	R	R/W	R/W	R/W	R	Reset Value
	SSUEND	SOPRDY	SDSTL	SUEND	DATAEND	STSTL	INPRDY	OPRDY	00000000
	Bit7	Bit6	Bit5	Bit4	Bit3	Bit2	Bit1	Bit0	USB Address: 0x11

Bit7: SSUEND: Serviced Setup End  
**Write:** Software should set this bit to ‘1’ after servicing a Setup End (bit SUEND) event. Hardware clears the SUEND bit when software writes ‘1’ to SSUEND.  
**Read:** This bit always reads ‘0’.

Bit6: SOPRDY: Serviced OPRDY  
**Write:** Software should write ‘1’ to this bit after servicing a received Endpoint0 packet. The OPRDY bit will be cleared by a write of ‘1’ to SOPRDY.  
**Read:** This bit always reads ‘0’.

Bit5: SDSTL: Send Stall  
Software can write ‘1’ to this bit to terminate the current transfer (due to an error condition, unexpected transfer request, etc.). Hardware will clear this bit to ‘0’ when the STALL handshake is transmitted.

Bit4: SUEND: Setup End  
Hardware sets this read-only bit to ‘1’ when a control transaction ends before software has written ‘1’ to the DATAEND bit. Hardware clears this bit when software writes ‘1’ to SSUEND.

Bit3: DATAEND: Data End  
Software should write ‘1’ to this bit:

1. When writing ‘1’ to INPRDY for the last outgoing data packet.
2. When writing ‘1’ to INPRDY for a zero-length data packet.
3. When writing ‘1’ to SOPRDY after servicing the last incoming data packet.

This bit is automatically cleared by hardware.

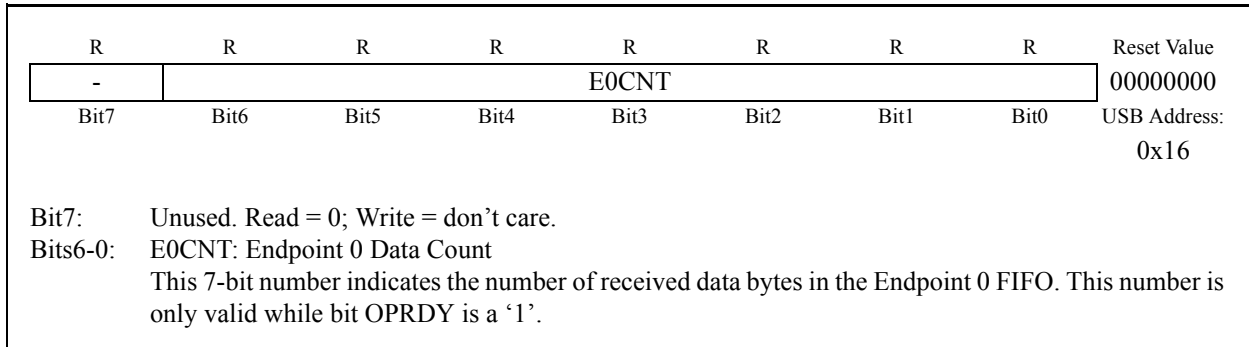
Bit2: STSTL: Sent Stall  
Hardware sets this bit to ‘1’ after transmitting a STALL handshake signal. This flag must be cleared by software.

Bit1: INPRDY: IN Packet Ready  
Software should write ‘1’ to this bit after loading a data packet into the Endpoint0 FIFO for transmit. Hardware clears this bit and generates an interrupt under either of the following conditions:

1. The packet is transmitted.
2. The packet is overwritten by an incoming SETUP packet.
3. The packet is overwritten by an incoming OUT packet.

Bit0: OPRDY: OUT Packet Ready  
Hardware sets this read-only bit and generates an interrupt when a data packet has been received. This bit is cleared only when software writes ‘1’ to the SOPRDY bit.

**Figure 15.21. E0CNT: USB0 Endpoint 0 Data Count (USB Register)**



## 15.11. Configuring Endpoints1-3

Endpoints1-3 are configured and controlled through their own sets of the following control/status registers: IN registers EINCSSL and EINCSRH, and OUT registers EOUTCSRL and EOUTCSRH. Only one set of endpoint control/status registers is mapped into the USB register address space at a time, defined by the contents of the INDEX register (Figure 15.6).

Endpoints1-3 can be configured as IN, OUT, or both IN/OUT (Split Mode) as described in [Section 15.5.1](#). The endpoint mode (Split/Normal) is selected via the SPLIT bit in register EINCSRH.

When SPLIT = '1', the corresponding endpoint FIFO is split, and both IN and OUT pipes are available.

When SPLIT = '0', the corresponding endpoint functions as either IN or OUT; the endpoint direction is selected by the DIRSEL bit in register EINCSRH.

## 15.12. Controlling Endpoints1-3 IN

Endpoints1-3 IN are managed via USB registers EINCSSL and EINCSRH. All IN endpoints can be used for Interrupt, Bulk, or Isochronous transfers. Isochronous (ISO) mode is enabled by writing '1' to the ISO bit in register EINCSRH. Bulk and Interrupt transfers are handled identically by hardware.

An Endpoint1-3 IN interrupt is generated by any of the following conditions:

1. An IN packet is successfully transferred to the host.
2. Software writes '1' to the FLUSH bit (EINCSSL.3) when the target FIFO is not empty.
3. Hardware generates a STALL condition.

### 15.12.1. Endpoints1-3 IN Interrupt or Bulk Mode

When the ISO bit (EINCSRH.6) = '0' the target endpoint operates in Bulk or Interrupt Mode. Once an endpoint has been configured to operate in Bulk/Interrupt IN mode (typically following an Endpoint0 SET\_INTERFACE command), firmware should load an IN packet into the endpoint IN FIFO and set the INPRDY bit (EINCSSL.0). Upon reception of an IN token, hardware will transmit the data, clear the INPRDY bit, and generate an interrupt.

Writing '1' to INPRDY without writing any data to the endpoint FIFO will cause a zero-length packet to be transmitted upon reception of the next IN token.

A Bulk or Interrupt pipe can be shut down (or Halted) by writing '1' to the SDSTL bit (EINCSSL.4). While SDSTL = '1', hardware will respond to all IN requests with a STALL condition. Each time hardware generates a STALL condition, an interrupt will be generated and the STSTL bit (EINCSSL.5) set to '1'. The STSTL bit must be reset to '0' by firmware.

Hardware will automatically reset INPRDY to '0' when a packet slot is open in the endpoint FIFO. Note that if double buffering is enabled for the target endpoint, it is possible for firmware to load two packets into the IN FIFO at a time. In this case, hardware will reset INPRDY to '0' immediately after firmware loads the first packet into the FIFO and sets INPRDY to '1'. An interrupt will not be generated in this case; an interrupt will only be generated when a data packet is transmitted.

When firmware writes '1' to the FCDT bit (EINCSRH.3), the data toggle for each IN packet will be toggled continuously, regardless of the handshake received from the host. This feature is typically used by Interrupt endpoints functioning as rate feedback communication for Isochronous endpoints. When FCDT = '0', the data toggle bit will only be toggled when an ACK is sent from the host in response to an IN packet.

---

## 15.12.2.Endpoints1-3 IN Isochronous Mode

When the ISO bit (EINCSRH.6) is set to '1', the target endpoint operates in Isochronous (ISO) mode. Once an endpoint has been configured for ISO IN mode, the host will send one IN token (data request) per frame; the location of data within each frame may vary. Because of this, it is recommended that double buffering be enabled for ISO IN endpoints.

Hardware will automatically reset INPRDY (EINCSRL.0) to '0' when a packet slot is open in the endpoint FIFO. Note that if double buffering is enabled for the target endpoint, it is possible for firmware to load two packets into the IN FIFO at a time. In this case, hardware will reset INPRDY to '0' immediately after firmware loads the first packet into the FIFO and sets INPRDY to '1'. An interrupt will not be generated in this case; an interrupt will only be generated when a data packet is transmitted.

If there is not a data packet ready in the endpoint FIFO when USB0 receives an IN token from the host, USB0 will transmit a zero-length data packet and set the UNDRUN bit (EINCSRL.2) to '1'.

The ISO Update feature (see [Section 15.7](#)) can be useful in starting a double buffered ISO IN endpoint. If the host has already set up the ISO IN pipe (has begun transmitting IN tokens) when firmware writes the first data packet to the endpoint FIFO, the next IN token may arrive and the first data packet sent before firmware has written the second (double buffered) data packet to the FIFO. The ISO Update feature ensures that any data packet written to the endpoint FIFO will not be transmitted during the current frame; the packet will only be sent after a SOF signal has been received.

**Figure 15.22. EINCSSL: USB0 IN Endpoint Control High Byte (USB Register)**

R	W	R/W	R/W	W	R/W	R/W	R/W	Reset Value
-	CLRDT	STSTL	SDSTL	FLUSH	UNDRUN	FIFONE	INPRDY	00000000
Bit7	Bit6	Bit5	Bit4	Bit3	Bit2	Bit1	Bit0	USB Address: 0x11

Bit7: Unused. Read = 0; Write = don't care.

Bit6: CLRDT: Clear Data Toggle.  
**Write:** Software should write '1' to this bit to reset the IN Endpoint data toggle to '0'.  
**Read:** This bit always reads '0'.

Bit5: STSTL: Sent Stall  
Hardware sets this bit to '1' when a STALL handshake signal is transmitted. The FIFO is flushed, and the INPRDY bit cleared. This flag must be cleared by software.

Bit4: SDSTL: Send Stall.  
Software should write '1' to this bit to generate a STALL handshake in response to an IN token. Software should write '0' to this bit to terminate the STALL signal. This bit has no effect in ISO mode.

Bit3: FLUSH: FIFO Flush.  
Writing a '1' to this bit flushes the next packet to be transmitted from the IN Endpoint FIFO. The FIFO pointer is reset and the INPRDY bit is cleared. If the FIFO contains multiple packets, software must write '1' to FLUSH for each packet. Hardware resets the FLUSH bit to '0' when the FIFO flush is complete.

Bit2: UNDRUN: Data Underrun.  
The function of this bit depends on the IN Endpoint mode:  
ISO: Set when a zero-length packet is sent after an IN token is received while bit INPRDY = '0'.  
Interrupt/Bulk: Set when a NAK is returned in response to an IN token.  
This bit must be cleared by software.

Bit1: FIFONE: FIFO Not Empty.  
0: The IN Endpoint FIFO is empty.  
1: The IN Endpoint FIFO contains one or more packets.

Bit0: INPRDY: In Packet Ready.  
Software should write '1' to this bit after loading a data packet into the IN Endpoint FIFO. Hardware clears INPRDY due to any of the following:  
1. A data packet is transmitted.  
2. Double buffering is enabled (DBIEN = '1') and there is an open FIFO packet slot.  
3. If the endpoint is in Isochronous Mode (ISO = '1') and ISOUD = '1', INPRDY will read '0' until the next SOF is received.  
**An interrupt (if enabled) will be generated when hardware clears INPRDY as a result of a packet being transmitted.**



**Figure 15.23. EINCSRH: USB0 IN Endpoint Control Low Byte (USB Register)**

R/W	R/W	R/W	R	R/W	R/W	R	R	Reset Value
DBIEN	ISO	DIRSEL	-	FCDT	SPLIT	-	-	00000000
Bit7	Bit6	Bit5	Bit4	Bit3	Bit2	Bit1	Bit0	USB Address: 0x12

Bit7: DBIEN: IN Endpoint Double-buffer Enable.  
0: Double-buffering disabled for the selected IN endpoint.  
1: Double-buffering enabled for the selected IN endpoint.

Bit6: ISO: Isochronous Transfer Enable.  
This bit enables/disables isochronous transfers on the current endpoint.  
0: Endpoint configured for bulk/interrupt transfers.  
1: Endpoint configured for isochronous transfers.

Bit5: DIRSEL: Endpoint Direction Select.  
This bit is valid only when the selected FIFO is not split (SPLIT = '0').  
0: Endpoint direction selected as OUT.  
1: Endpoint direction selected as IN.

Bit4: Unused. Read = '0'. Write = don't care.

Bit3: FCDT: Force Data Toggle.  
0: Endpoint data toggle switches only when an ACK is received following a data packet transmission.  
1: Endpoint data toggle forced to switch after every data packet is transmitted, regardless of ACK reception.

Bit2: SPLIT: FIFO Split Enable.  
When SPLIT = '1', the selected endpoint FIFO is split. The upper half of the selected FIFO is used by the IN endpoint; the lower half of the selected FIFO is used by the OUT endpoint.

Bits1-0: Unused. Read = 00b; Write = don't care.

## 15.13. Controlling Endpoints1-3 OUT

Endpoints1-3 OUT are managed via USB registers EOUTCSRL and EOUTCSRH. All OUT endpoints can be used for Interrupt, Bulk, or Isochronous transfers. Isochronous (ISO) mode is enabled by writing '1' to the ISO bit in register EOUTCSRH. Bulk and Interrupt transfers are handled identically by hardware.

An Endpoint1-3 OUT interrupt may be generated by the following:

1. Hardware sets the OPRDY bit (EINCSRL.0) to '1'.
2. Hardware generates a STALL condition.

### 15.13.1.Endpoints1-3 OUT Interrupt or Bulk Mode

When the ISO bit (EOUTCSRH.6) = '0' the target endpoint operates in Bulk or Interrupt mode. Once an endpoint has been configured to operate in Bulk/Interrupt OUT mode (typically following an Endpoint0 SET\_INTERFACE command), hardware will set the OPRDY bit (EOUTCSRL.0) to '1' and generate an interrupt upon reception of an OUT token and data packet. The number of bytes in the current OUT data packet (the packet ready to be unloaded from the FIFO) is given in the EOUTCNTH and EOUTCNTL registers. In response to this interrupt, firmware should unload the data packet from the OUT FIFO and reset the OPRDY bit to '0'.

A Bulk or Interrupt pipe can be shut down (or Halted) by writing '1' to the SDSTL bit (EOUTCSRL.5). While SDSTL = '1', hardware will respond to all OUT requests with a STALL condition. Each time hardware generates a STALL condition, an interrupt will be generated and the STSTL bit (EOUTCSRL.6) set to '1'. The STSTL bit must be reset to '0' by firmware.

Hardware will automatically set OPRDY when a packet is ready in the OUT FIFO. Note that if double buffering is enabled for the target endpoint, it is possible for two packets to be ready in the OUT FIFO at a time. In this case, hardware will set OPRDY to '1' immediately after firmware unloads the first packet and resets OPRDY to '0'. A second interrupt will be generated in this case.

### 15.13.2.Endpoints1-3 OUT Isochronous Mode

When the ISO bit (EOUTCSRH.6) is set to '1', the target endpoint operates in Isochronous (ISO) mode. Once an endpoint has been configured for ISO OUT mode, the host will send exactly one data per USB frame; the location of the data packet within each frame may vary, however. Because of this, it is recommended that double buffering be enabled for ISO OUT endpoints.

Each time a data packet is received, hardware will load the received data packet into the endpoint FIFO, set the OPRDY bit (EOUTCSRL.0) to '1', and generate an interrupt (if enabled). Firmware would typically use this interrupt to unload the data packet from the endpoint FIFO and reset the OPRDY bit to '0'.

If a data packet is received when there is no room in the endpoint FIFO, an interrupt will be generated and the OVRUN bit (EOUTCSRL.2) set to '1'. If USB0 receives an ISO data packet with a CRC error, the data packet will be loaded into the endpoint FIFO, OPRDY will be set to '1', an interrupt (if enabled) will be generated, and the DATAERR bit (EOUTCSRL.3) will be set to '1'. Software should check the DATAERR bit each time a data packet is unloaded from an ISO OUT endpoint FIFO.

**Figure 15.24. EOUTCSRL: USB0 OUT Endpoint Control High Byte (USB Register)**

	W	R/W	R/W	W	R	R/W	R	R/W	Reset Value
	CLRDT	STSTL	SDSTL	FLUSH	DATERR	OVRUN	FIFOFUL	OPRDY	00000000
	Bit7	Bit6	Bit5	Bit4	Bit3	Bit2	Bit1	Bit0	USB Address: 0x14
Bit7:	<p>CLRDT: Clear Data Toggle  <b>Write:</b> Software should write ‘1’ to this bit to reset the OUT endpoint data toggle to ‘0’.  <b>Read:</b> This bit always reads ‘0’.</p>								
Bit6:	<p>STSTL: Sent Stall  Hardware sets this bit to ‘1’ when a STALL handshake signal is transmitted. This flag must be cleared by software.</p>								
Bit5:	<p>SDSTL: Send Stall  Software should write ‘1’ to this bit to generate a STALL handshake. Software should write ‘0’ to this bit to terminate the STALL signal. This bit has no effect in ISO mode.</p>								
Bit4:	<p>FLUSH: FIFO Flush  Writing a ‘1’ to this bit flushes the next packet to be read from the OUT endpoint FIFO. The FIFO pointer is reset and the OPRDY bit is cleared. If the FIFO contains multiple packets, software must write ‘1’ to FLUSH for each packet. Hardware resets the FLUSH bit to ‘0’ when the FIFO flush is complete.</p>								
Bit3:	<p>DATERR: Data Error  In ISO mode, this bit is set by hardware if a received packet has a CRC or bit-stuffing error. It is cleared when software clears OPRDY. This bit is only valid in ISO mode.</p>								
Bit2:	<p>OVRUN: Data Overrun  This bit is set by hardware when an incoming data packet cannot be loaded into the OUT endpoint FIFO. This bit is only valid in ISO mode, and must be cleared by software.  0: No data overrun.  1: A data packet was lost because of a full FIFO since this flag was last cleared.</p>								
Bit1:	<p>FIFOFUL: OUT FIFO Full  This bit indicates the contents of the OUT FIFO. If double buffering is enabled for the endpoint (DBIEN = ‘1’), the FIFO is full when the FIFO contains two packets. If DBIEN = ‘0’, the FIFO is full when the FIFO contains one packet.  0: OUT endpoint FIFO is not full.  1: OUT endpoint FIFO is full.</p>								
Bit0:	<p>OPRDY: OUT Packet Ready  Hardware sets this bit to ‘1’ and generates an interrupt when a data packet is available. Software should clear this bit after each data packet is unloaded from the OUT endpoint FIFO.</p>								

**Figure 15.25. EOUTCSRH: USB0 OUT Endpoint Control Low Byte (USB Register)**

R/W	R/W	R/W	R/W	R	R	R	R	Reset Value
DBOEN	ISO	-	-	-	-	-	-	00000000
Bit7	Bit6	Bit5	Bit4	Bit3	Bit2	Bit1	Bit0	USB Address: 0x15

Bit7: DBOEN: Double-buffer Enable  
0: Double-buffering disabled for the selected OUT endpoint.  
1: Double-buffering enabled for the selected OUT endpoint.

Bit6: ISO: Isochronous Transfer Enable  
This bit enables/disables isochronous transfers on the current endpoint.  
0: Endpoint configured for bulk/interrupt transfers.  
1: Endpoint configured for isochronous transfers.

Bits5-0: Unused. Read = 000000b; Write = don't care.

**Figure 15.26. EOUTCNTL: USB0 OUT Endpoint Count Low (USB Register)**

R	R	R	R	R	R	R	R	Reset Value
EOCL								00000000
Bit7	Bit6	Bit5	Bit4	Bit3	Bit2	Bit1	Bit0	USB Address: 0x16

Bits7-0: EOCL: OUT Endpoint Count Low Byte  
EOCL holds the lower 8-bits of the 10-bit number of data bytes in the last received packet in the current OUT endpoint FIFO. This number is only valid while OPRDY = '1'.

**Figure 15.27. EOUTCNTH: USB0 OUT Endpoint Count High (USB Register)**

R	R	R	R	R	R	R	R	Reset Value
-	-	-	-	-	-	EOCH		00000000
Bit7	Bit6	Bit5	Bit4	Bit3	Bit2	Bit1	Bit0	USB Address: 0x17

Bits7-2: Unused. Read = 00000. Write = don't care.

Bits1-0: EOCH: OUT Endpoint Count High Byte  
EOCH holds the upper 2-bits of the 10-bit number of data bytes in the last received packet in the current OUT endpoint FIFO. This number is only valid while OPRDY = '1'.

**Table 15.4. USB Transceiver Electrical Characteristics**

VDD = 3.0 to 3.6V, -40°C to +85°C unless otherwise specified

PARAMETERS	SYMBOL	CONDITIONS	MIN	TYP	MAX	UNITS
<b>TRANSMITTER</b>						
Output High Voltage	$V_{OH}$		2.8			V
Output Low Voltage	$V_{OL}$				0.8	V
Output Crossover Point	$V_{CRS}$		1.3		2.0	V
Output Impedance	$Z_{DRV}$	Driving High		38		$\Omega$
		Driving Low		38		
Pull-up Resistance	$R_{PU}$	Full Speed (D+ Pull-up)	1.425	1.5	1.575	k $\Omega$
		Low Speed (D- Pull-up)				
Output Rise Time	$T_R$	Low Speed	75		300	ns
		Full Speed	4		20	
Output Fall Time	$T_F$	Low Speed	75		300	ns
		Full Speed	4		20	
<b>RECEIVER</b>						
Differential Input Sensitivity	$V_{DI}$	(D+) - (D-)	0.2			V
Differential Input Common Mode Range	$V_{CM}$		0.8		2.5	V
Input Leakage Current	$I_L$	Pullups Disabled		<1.0		$\mu$ A

Note: Refer to the USB Specification for timing diagrams and symbol definitions.

---

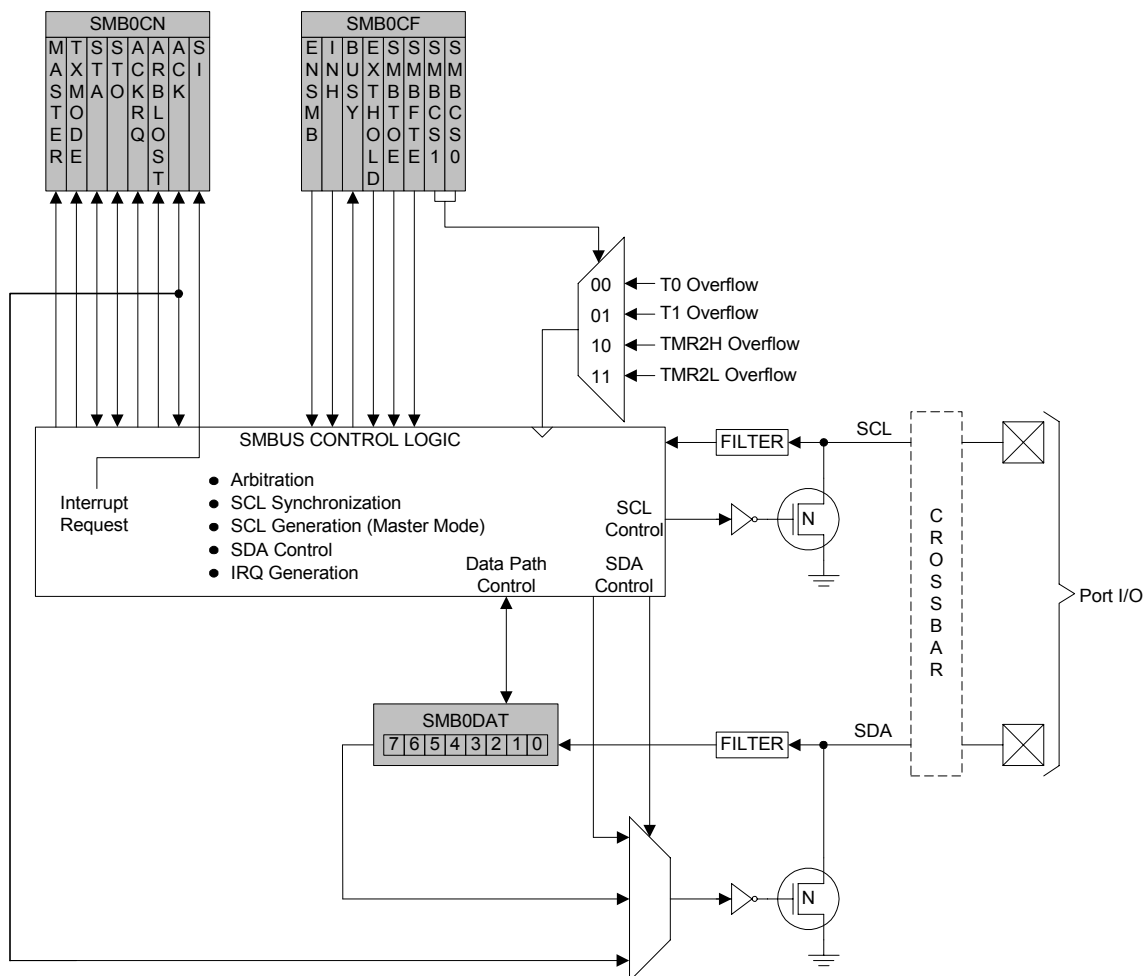
*Notes*

## 16. SMBUS

The SMBus I/O interface is a two-wire, bi-directional serial bus. The SMBus is compliant with the System Management Bus Specification, version 1.1, and compatible with the I<sup>2</sup>C serial bus. Reads and writes to the interface by the system controller are byte oriented with the SMBus interface autonomously controlling the serial transfer of the data. Data can be transferred at up to 1/10th of the system clock as a master or slave (this can be faster than allowed by the SMBus specification, depending on the system clock used). A method of extending the clock-low duration is available to accommodate devices with different speed capabilities on the same bus.

The SMBus interface may operate as a master and/or slave, and may function on a bus with multiple masters. The SMBus provides control of SDA (serial data), SCL (serial clock) generation and synchronization, arbitration logic, and START/STOP control and generation. Three SFRs are associated with the SMBus: SMB0CN configures the SMBus; SMB0CF controls the status of the SMBus; and SMB0DAT is the data register, used for both transmitting and receiving SMBus data and slave addresses.

**Figure 16.1. SMBus Block Diagram**



## 16.1. Supporting Documents

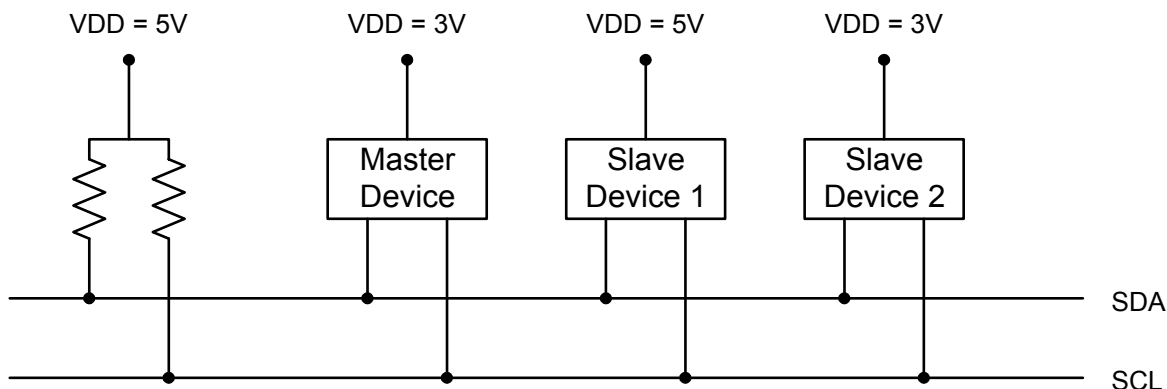
It is assumed the reader is familiar with or has access to the following supporting documents:

1. The I<sup>2</sup>C-Bus and How to Use It (including specifications), Philips Semiconductor.
2. The I<sup>2</sup>C-Bus Specification -- Version 2.0, Philips Semiconductor.
3. System Management Bus Specification -- Version 1.1, SBS Implementers Forum.

## 16.2. SMBus Configuration

Figure 16.2 shows a typical SMBus configuration. The SMBus specification allows any recessive voltage between 3.0 V and 5.0 V; different devices on the bus may operate at different voltage levels. The bi-directional SCL (serial clock) and SDA (serial data) lines must be connected to a positive power supply voltage through a pull-up resistor or similar circuit. Every device connected to the bus must have an open-drain or open-collector output for both the SCL and SDA lines, so that both are pulled high (recessive state) when the bus is free. The maximum number of devices on the bus is limited only by the requirement that the rise and fall times on the bus not exceed 300 ns and 1000 ns, respectively.

**Figure 16.2. Typical SMBus Configuration**





### 16.3. SMBus Operation

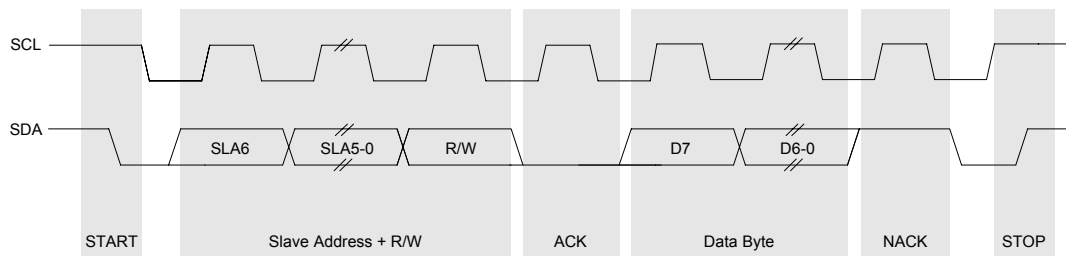
Two types of data transfers are possible: data transfers from a master transmitter to an addressed slave receiver (WRITE), and data transfers from an addressed slave transmitter to a master receiver (READ). The master device initiates both types of data transfers and provides the serial clock pulses on SCL. The SMBus interface may operate as a master or a slave, and multiple master devices on the same bus are supported. If two or more masters attempt to initiate a data transfer simultaneously, an arbitration scheme is employed with a single master always winning the arbitration. Note that it is not necessary to specify one device as the Master in a system; any device who transmits a START and a slave address becomes the master for the duration of that transfer.

A typical SMBus transaction consists of a START condition followed by an address byte (Bits7-1: 7-bit slave address; Bit0: R/W direction bit), one or more bytes of data, and a STOP condition. Each byte that is received (by a master or slave) must be acknowledged (ACK) with a low SDA during a high SCL (see Figure 16.3). If the receiving device does not ACK, the transmitting device will read a NACK (not acknowledge), which is a high SDA during a high SCL.

The direction bit (R/W) occupies the least-significant bit position of the address byte. The direction bit is set to logic 1 to indicate a "READ" operation and cleared to logic 0 to indicate a "WRITE" operation.

All transactions are initiated by a master, with one or more addressed slave devices as the target. The master generates the START condition and then transmits the slave address and direction bit. If the transaction is a WRITE operation from the master to the slave, the master transmits the data a byte at a time waiting for an ACK from the slave at the end of each byte. For READ operations, the slave transmits the data waiting for an ACK from the master at the end of each byte. At the end of the data transfer, the master generates a STOP condition to terminate the transaction and free the bus. Figure 16.3 illustrates a typical SMBus transaction.

**Figure 16.3. SMBus Transaction**



#### 16.3.1. Arbitration

A master may start a transfer only if the bus is free. The bus is free after a STOP condition or after the SCL and SDA lines remain high for a specified time (see [Section "16.3.4. SCL High \(SMBus Free\) Timeout" on page 178](#)). In the event that two or more devices attempt to begin a transfer at the same time, an arbitration scheme is employed to force one master to give up the bus. The master devices continue transmitting until one attempts a HIGH while the other transmits a LOW. Since the bus is open-drain, the bus will be pulled LOW. The master attempting the HIGH will detect a LOW SDA and lose the arbitration. The winning master continues its transmission without interruption; the losing master becomes a slave and receives the rest of the transfer if addressed. This arbitration scheme is non-destructive: one device always wins, and no data is lost.

## 16.3.2. Clock Low Extension

SMBus provides a clock synchronization mechanism, similar to I<sup>2</sup>C, which allows devices with different speed capabilities to coexist on the bus. A clock-low extension is used during a transfer in order to allow slower slave devices to communicate with faster masters. The slave may temporarily hold the SCL line LOW to extend the clock low period, effectively decreasing the serial clock frequency.

## 16.3.3. SCL Low Timeout

If the SCL line is held low by a slave device on the bus, no further communication is possible. Furthermore, the master cannot force the SCL line high to correct the error condition. To solve this problem, the SMBus protocol specifies that devices participating in a transfer must detect any clock cycle held low longer than 25 ms as a “timeout” condition. Devices that have detected the timeout condition must reset the communication no later than 10 ms after detecting the timeout condition.

When the SMBTOE bit in SMB0CF is set, Timer 3 is used to detect SCL low timeouts. Timer 3 is forced to reload when SCL is high, and allowed to count when SCL is low. With Timer 3 enabled and configured to overflow after 25 ms (and SMBTOE set), the Timer 3 interrupt service routine can be used to reset (disable and re-enable) the SMBus in the event of an SCL low timeout.

## 16.3.4. SCL High (SMBus Free) Timeout

The SMBus specification stipulates that if the SCL and SDA lines remain high for more than 50  $\mu$ s, the bus is designated as free. When the SMBFTE bit in SMB0CF is set, the bus will be considered free if SCL and SDA remain high for more than 10 SMBus clock source periods. If the SMBus is waiting to generate a Master START, the START will be generated following this timeout. Note that a clock source is required for free timeout detection, even in a slave-only implementation.

---

## 16.4. Using the SMBus

The SMBus can operate in both Master and Slave modes. The interface provides timing and shifting control for serial transfers; higher level protocol is determined by user software. The SMBus interface provides the following application-independent features:

- Byte-wise serial data transfers
- Clock signal generation on SCL (Master Mode only) and SDA data synchronization
- Timeout/bus error recognition, as defined by the SMB0CF configuration register
- START/STOP timing, detection, and generation
- Bus arbitration
- Interrupt generation
- Status information

SMBus interrupts are generated for each data byte or slave address that is transferred. When transmitting, this interrupt is generated after the ACK cycle so that software may read the received ACK value; when receiving data, this interrupt is generated before the ACK cycle so that software may define the outgoing ACK value. See [Section “16.5. SMBus Transfer Modes” on page 187](#) for more details on transmission sequences.

Interrupts are also generated to indicate the beginning of a transfer when a master (START generated), or the end of a transfer when a slave (STOP detected). Software should read the SMB0CN (SMBus Control register) to find the cause of the SMBus interrupt. The SMB0CN register is described in [Section “16.4.2. SMB0CN Control Register” on page 183](#); Table 16.4 provides a quick SMB0CN decoding reference.

SMBus configuration options include:

- Timeout detection (SCL Low Timeout and/or Bus Free Timeout)
- SDA setup and hold time extensions
- Slave event enable/disable
- Clock source selection

These options are selected in the SMB0CF register, as described in [Section “16.4.1. SMBus Configuration Register” on page 180](#).

## 16.4.1. SMBus Configuration Register

The SMBus Configuration register (SMB0CF) is used to enable the SMBus Master and/or Slave modes, select the SMBus clock source, and select the SMBus timing and timeout options. When the ENSMB bit is set, the SMBus is enabled for all master and slave events. Slave events may be disabled by setting the INH bit. With slave events inhibited, the SMBus interface will still monitor the SCL and SDA pins; however, the interface will NACK all received addresses and will not generate any slave interrupts. When the INH bit is set, all slave events will be inhibited following the next START (interrupts will continue for the duration of the current transfer).

**Table 16.1. SMBus Clock Source Selection**

SMBCS1	SMBCS0	SMBus Clock Source
0	0	Timer 0 Overflow
0	1	Timer 1 Overflow
1	0	Timer 2 High Byte Overflow
1	1	Timer 2 Low Byte Overflow

The SMBCS1-0 bits select the SMBus clock source, which is used only when operating as a master or when the Free Timeout detection is enabled. When operating as a master, overflows from the selected source determine the absolute minimum SCL low and high times as defined in Equation 16.1. Note that the selected clock source may be shared by other peripherals so long as the timer is left running at all times. For example, Timer 1 overflows may generate the SMBus and UART baud rates simultaneously. Timer configuration is covered in [Section “19. Timers” on page 217](#).

### Equation 16.1. Minimum SCL High and Low Times

$$T_{HighMin} = T_{LowMin} = \frac{1}{f_{ClockSourceOverflow}}$$

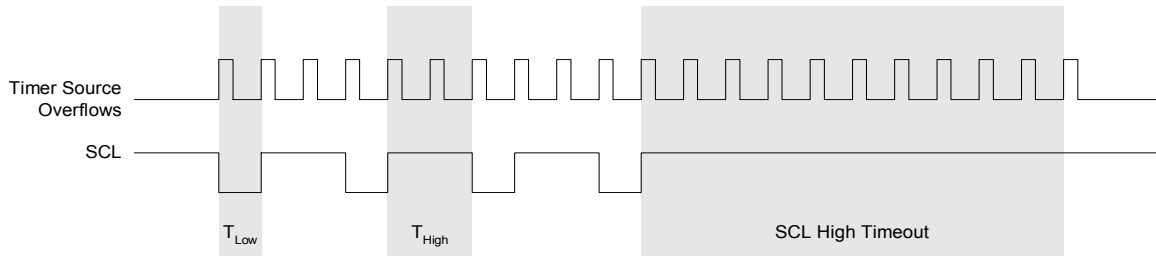
The selected clock source should be configured to establish the minimum SCL High and Low times as per Equation 16.1. When the interface is operating as a master (and SCL is not driven or extended by any other devices on the bus), the typical SMBus bit rate is approximated by Equation 16.2.

### Equation 16.2. Typical SMBus Bit Rate

$$BitRate = \frac{f_{ClockSourceOverflow}}{3}$$

Figure 16.4 shows the typical SCL generation described by Equation 16.2. Notice that  $T_{HIGH}$  is typically twice as large as  $T_{LOW}$ . The actual SCL output may vary due to other devices on the bus (SCL may be extended low by slower slave devices, or driven low by contending master devices). The bit rate when operating as a master will never exceed the limits defined by equation Equation 16.1.

**Figure 16.4. Typical SMBus SCL Generation**



Setting the EXTHOLD bit extends the minimum setup and hold times for the SDA line. The minimum SDA setup time defines the absolute minimum time that SDA is stable before SCL transitions from low-to-high. The minimum SDA hold time defines the absolute minimum time that the current SDA value remains stable after SCL transitions from high-to-low. EXTHOLD should be set so that the minimum setup and hold times meet the SMBus Specification requirements of 250 ns and 300 ns, respectively. Table 16.2 shows the minimum setup and hold times for the two EXTHOLD settings. Setup and hold time extensions are typically necessary when SYSCLK is above 10 MHz.

**Table 16.2. Minimum SDA Setup and Hold Times**

EXTHOLD	Minimum SDA Setup Time	Minimum SDA Hold Time
0	$T_{low} - 4$ system clocks OR 1 system clock + s/w delay <sup>†</sup>	3 system clocks
1	11 system clocks	12 system clocks

<sup>†</sup>Setup Time for ACK bit transmissions and the MSB of all data transfers. The s/w delay occurs between the time SMB0DAT or ACK is written and when SI is cleared. Note that if SI is cleared in the same write that defines the outgoing ACK value, s/w delay is zero.

With the SMBTOE bit set, Timer 3 should be configured to overflow after 25 ms in order to detect SCL low timeouts (see **Section “16.3.3. SCL Low Timeout” on page 178**). The SMBus interface will force Timer 3 to reload while SCL is high, and allow Timer 3 to count when SCL is low. The Timer 3 interrupt service routine should be used to reset SMBus communication by disabling and re-enabling the SMBus.

SMBus Free Timeout detection can be enabled by setting the SMBFTE bit. When this bit is set, the bus will be considered free if SDA and SCL remain high for more than 10 SMBus clock source periods (see Figure 16.4). When a Free Timeout is detected, the interface will respond as if a STOP was detected (an interrupt will be generated, and STO will be set).

**Figure 16.5. SMB0CF: SMBus Clock/Configuration Register**

R/W	R/W	R	R/W	R/W	R/W	R/W	R/W	Reset Value
ENSMB	INH	BUSY	EXTHOLD	SMBTOE	SMBFTE	SMBCS1	SMBCS0	00000000
Bit7	Bit6	Bit5	Bit4	Bit3	Bit2	Bit1	Bit0	

SFR Address: 0xC1

Bit7: ENSMB: SMBus Enable.  
This bit enables/disables the SMBus interface. When enabled, the interface constantly monitors the SDA and SCL pins.  
0: SMBus interface disabled.  
1: SMBus interface enabled.

Bit6: INH: SMBus Slave Inhibit.  
When this bit is set to logic 1, the SMBus does not generate an interrupt when slave events occur. This effectively removes the SMBus slave from the bus. Master Mode interrupts are not affected.  
0: SMBus Slave Mode enabled.  
1: SMBus Slave Mode inhibited.

Bit5: BUSY: SMBus Busy Indicator.  
This bit is set to logic 1 by hardware when a transfer is in progress. It is cleared to logic 0 when a STOP or free-timeout is sensed.

Bit4: EXTHOLD: SMBus Setup and Hold Time Extension Enable.  
This bit controls the SDA setup and hold times according to .  
0: SDA Extended Setup and Hold Times disabled.  
1: SDA Extended Setup and Hold Times enabled.

Bit3: SMBTOE: SMBus SCL Timeout Detection Enable.  
This bit enables SCL low timeout detection. If set to logic 1, the SMBus forces Timer 3 to reload while SCL is high and allows Timer 3 to count when SCL goes low. Timer 3 should be programmed to generate interrupts at 25 ms, and the Timer 3 interrupt service routine should reset SMBus communication.

Bit2: SMBFTE: SMBus Free Timeout Detection Enable.  
When this bit is set to logic 1, the bus will be considered free if SCL and SDA remain high for more than 10 SMBus clock source periods.

Bits1-0: SMBCS1-SMBCS0: SMBus Clock Source Selection.  
These two bits select the SMBus clock source, which is used to generate the SMBus bit rate. The selected device should be configured according to Equation 16.1.

SMBCS1	SMBCS0	SMBus Clock Source
0	0	Timer 0 Overflow
0	1	Timer 1 Overflow
1	0	Timer 2 High Byte Overflow
1	1	Timer 2 Low Byte Overflow

---

## 16.4.2. SMB0CN Control Register

SMB0CN is used to control the interface and to provide status information (see Figure 16.6). The higher four bits of SMB0CN (MASTER, TXMODE, STA, and STO) form a status vector that can be used to jump to service routines. MASTER and TXMODE indicate the master/slave state and transmit/receive modes, respectively.

STA and STO indicate that a START and/or STOP has been detected or generated since the last SMBus interrupt. STA and STO are also used to generate START and STOP conditions when operating as a master. Writing a '1' to STA will cause the SMBus interface to enter Master Mode and generate a START when the bus becomes free (STA is not cleared by hardware after the START is generated). Writing a '1' to STO while in Master Mode will cause the interface to generate a STOP and end the current transfer after the next ACK cycle. If STO and STA are both set (while in Master Mode), a STOP followed by a START will be generated.

As a receiver, writing the ACK bit defines the outgoing ACK value; as a transmitter, reading the ACK bit indicates the value received on the last ACK cycle. ACKRQ is set each time a byte is received, indicating that an outgoing ACK value is needed. When ACKRQ is set, software should write the desired outgoing value to the ACK bit before clearing SI. A NACK will be generated if software does not write the ACK bit before clearing SI. SDA will reflect the defined ACK value immediately following a write to the ACK bit; however SCL will remain low until SI is cleared. If a received slave address is not acknowledged, further slave events will be ignored until the next START is detected.

The ARBLOST bit indicates that the interface has lost an arbitration. This may occur anytime the interface is transmitting (master or slave). A lost arbitration while operating as a slave indicates a bus error condition. ARBLOST is cleared by hardware each time SI is cleared.

The SI bit (SMBus Interrupt Flag) is set at the beginning and end of each transfer, after each byte frame, or when an arbitration is lost; see Table 16.3 for more details.

**Important Note About the SI Bit:** The SMBus interface is stalled while SI is set; thus SCL is held low, and the bus is stalled until software clears SI.

Table 16.3 lists all sources for hardware changes to the SMB0CN bits. Refer to Table 16.4 for SMBus status decoding using the SMB0CN register.

**Figure 16.6. SMB0CN: SMBus Control Register**

R	R	R/W	R/W	R	R	R/W	R/W	Reset Value
MASTER	TXMODE	STA	STO	ACKRQ	ARBLOST	ACK	SI	00000000
Bit7	Bit6	Bit5	Bit4	Bit3	Bit2	Bit1	Bit0	Bit Addressable
								SFR Address: 0xC0
Bit7:	<p>MASTER: SMBus Master/Slave Indicator. This read-only bit indicates when the SMBus is operating as a master. 0: SMBus operating in Slave Mode. 1: SMBus operating in Master Mode.</p>							
Bit6:	<p>TXMODE: SMBus Transmit Mode Indicator. This read-only bit indicates when the SMBus is operating as a transmitter. 0: SMBus in Receiver Mode. 1: SMBus in Transmitter Mode.</p>							
Bit5:	<p>STA: SMBus Start Flag. Write: 0: No Start generated. 1: When operating as a master, a START condition is transmitted if the bus is free (If the bus is not free, the START is transmitted after a STOP is received or a timeout is detected). If STA is set by software as an active Master, a repeated START will be generated after the next ACK cycle. Read: 0: No Start or repeated Start detected. 1: Start or repeated Start detected.</p>							
Bit4:	<p>STO: SMBus Stop Flag. Write: 0: No STOP condition is transmitted. 1: Setting STO to logic 1 causes a STOP condition to be transmitted after the next ACK cycle. When the STOP condition is generated, hardware clears STO to logic 0. If both STA and STO are set, a STOP condition is transmitted followed by a START condition. Read: 0: No Stop condition detected. 1: Stop condition detected (if in Slave Mode) or pending (if in Master Mode).</p>							
Bit3:	<p>ACKRQ: SMBus Acknowledge Request This read-only bit is set to logic 1 when the SMBus has received a byte and needs the ACK bit to be written with the correct ACK response value.</p>							
Bit2:	<p>ARBLOST: SMBus Arbitration Lost Indicator. This read-only bit is set to logic 1 when the SMBus loses arbitration while operating as a transmitter. A lost arbitration while a slave indicates a bus error condition.</p>							
Bit1:	<p>ACK: SMBus Acknowledge Flag. This bit defines the out-going ACK level and records incoming ACK levels. It should be written each time a byte is received (when ACKRQ=1), or read after each byte is transmitted. 0: A "not acknowledge" has been received (if in Transmitter Mode) OR will be transmitted (if in Receiver Mode). 1: An "acknowledge" has been received (if in Transmitter Mode) OR will be transmitted (if in Receiver Mode).</p>							
Bit0:	<p>SI: SMBus Interrupt Flag. This bit is set by hardware under the conditions listed in Table 16.3. SI must be cleared by software. While SI is set, SCL is held low and the SMBus is stalled.</p>							



Table 16.3. Sources for Hardware Changes to SMB0CN

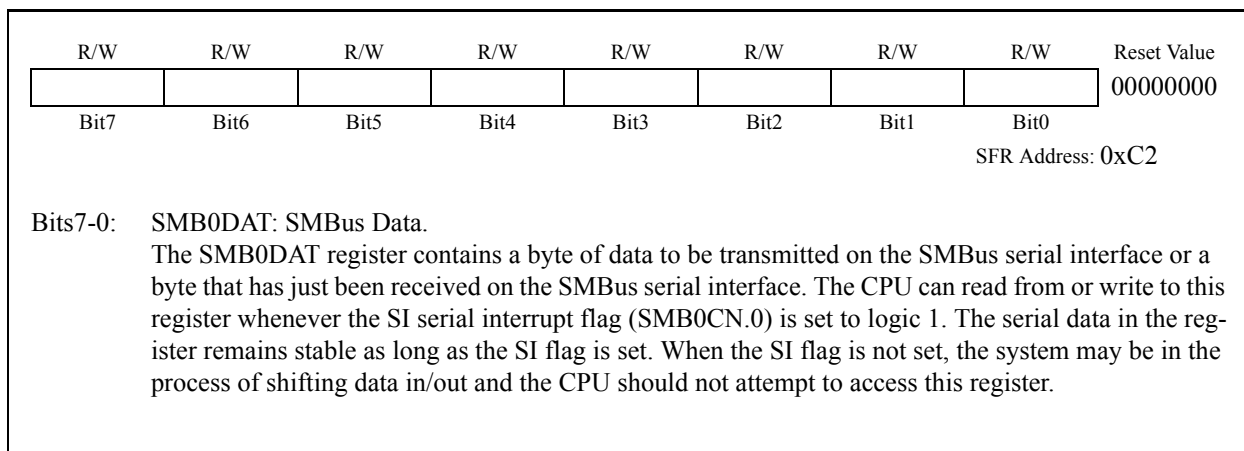
Bit	Set by Hardware When:	Cleared by Hardware When:
MASTER	<ul style="list-style-type: none"> <li>• A START is generated.</li> </ul>	<ul style="list-style-type: none"> <li>• A STOP is generated.</li> <li>• Arbitration is lost.</li> </ul>
TXMODE	<ul style="list-style-type: none"> <li>• START is generated.</li> <li>• SMB0DAT is written before the start of an SMBus frame.</li> </ul>	<ul style="list-style-type: none"> <li>• A START is detected.</li> <li>• Arbitration is lost.</li> <li>• SMB0DAT is not written before the start of an SMBus frame.</li> </ul>
STA	<ul style="list-style-type: none"> <li>• A START followed by an address byte is received.</li> </ul>	<ul style="list-style-type: none"> <li>• Must be cleared by software.</li> </ul>
STO	<ul style="list-style-type: none"> <li>• A STOP is detected while addressed as a slave.</li> <li>• Arbitration is lost due to a detected STOP.</li> </ul>	<ul style="list-style-type: none"> <li>• A pending STOP is generated.</li> </ul>
ACKRQ	<ul style="list-style-type: none"> <li>• A byte has been received and an ACK response value is needed.</li> </ul>	<ul style="list-style-type: none"> <li>• After each ACK cycle.</li> </ul>
ARBLOST	<ul style="list-style-type: none"> <li>• A repeated START is detected as a MASTER when STA is low (unwanted repeated START).</li> <li>• SCL is sensed low while attempting to generate a STOP or repeated START condition.</li> <li>• SDA is sensed low while transmitting a '1' (excluding ACK bits).</li> </ul>	<ul style="list-style-type: none"> <li>• Each time SI is cleared.</li> </ul>
ACK	<ul style="list-style-type: none"> <li>• The incoming ACK value is low (ACKNOWLEDGE).</li> </ul>	<ul style="list-style-type: none"> <li>• The incoming ACK value is high (NOT ACKNOWLEDGE).</li> </ul>
SI	<ul style="list-style-type: none"> <li>• A START has been generated.</li> <li>• Lost arbitration.</li> <li>• A byte has been transmitted and an ACK/NACK received.</li> <li>• A byte has been received.</li> <li>• A START or repeated START followed by a slave address + R/W has been received.</li> <li>• A STOP has been received.</li> </ul>	<ul style="list-style-type: none"> <li>• Must be cleared by software.</li> </ul>

## 16.4.3. Data Register

The SMBus Data register SMB0DAT holds a byte of serial data to be transmitted or one that has just been received. Software may safely read or write to the data register when the SI flag is set. Software should not attempt to access the SMB0DAT register when the SMBus is enabled and the SI flag is cleared to logic 0, as the interface may be in the process of shifting a byte of data into or out of the register.

Data in SMB0DAT is always shifted out MSB first. After a byte has been received, the first bit of received data is located at the MSB of SMB0DAT. While data is being shifted out, data on the bus is simultaneously being shifted in. SMB0DAT always contains the last data byte present on the bus. In the event of lost arbitration, the transition from master transmitter to slave receiver is made with the correct data or address in SMB0DAT.

**Figure 16.7. SMB0DAT: SMBus Data Register**



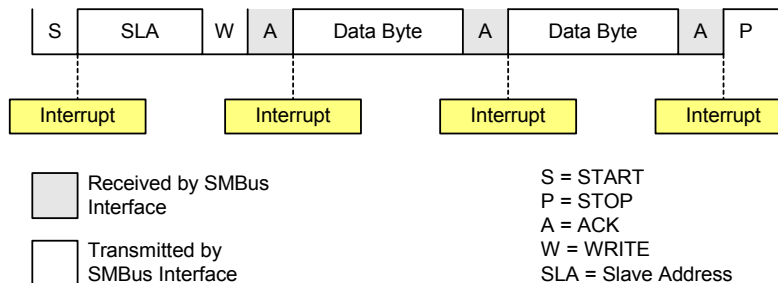
## 16.5. SMBus Transfer Modes

The SMBus interface may be configured to operate as master and/or slave. At any particular time, it will be operating in one of the following four modes: Master Transmitter, Master Receiver, Slave Transmitter, or Slave Receiver. The SMBus interface enters Master Mode any time a START is generated, and remains in Master Mode until it loses an arbitration or generates a STOP. An SMBus interrupt is generated at the end of all SMBus byte frames; however, note that the interrupt is generated before the ACK cycle when operating as a receiver, and after the ACK cycle when operating as a transmitter.

### 16.5.1. Master Transmitter Mode

Serial data is transmitted on SDA while the serial clock is output on SCL. The SMBus interface generates the START condition and transmits the first byte containing the address of the target slave and the data direction bit. In this case the data direction bit (R/W) will be logic 0 (WRITE). The master then transmits one or more bytes of serial data. After each byte is transmitted, an acknowledge bit is generated by the slave. The transfer is ended when the STO bit is set and a STOP is generated. Note that the interface will switch to Master Receiver Mode if SMB0DAT is not written following a Master Transmitter interrupt. Figure 16.8 shows a typical Master Transmitter sequence. Two transmit data bytes are shown, though any number of bytes may be transmitted. Notice that the ‘data byte transferred’ interrupts occur **after** the ACK cycle in this mode.

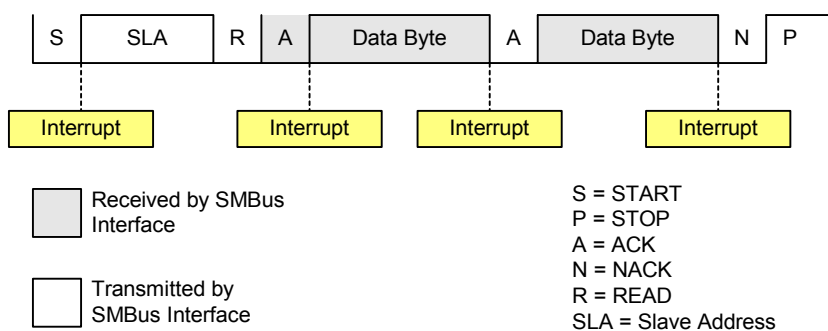
**Figure 16.8. Typical Master Transmitter Sequence**



## 16.5.2. Master Receiver Mode

Serial data is received on SDA while the serial clock is output on SCL. The SMBus interface generates the START condition and transmits the first byte containing the address of the target slave and the data direction bit. In this case the data direction bit (R/W) will be logic 1 (READ). Serial data is then received from the slave on SDA while the SMBus outputs the serial clock. The slave transmits one or more bytes of serial data. After each byte is received, ACKRQ is set to '1' and an interrupt is generated. Software must write the ACK bit (SMB0CN.1) to define the outgoing acknowledge value (Note: writing a '1' to the ACK bit generates an ACK; writing a '0' generates a NACK). Software should write a '0' to the ACK bit after the last byte is received, to transmit a NACK. The interface exits Master Receiver Mode after the STO bit is set and a STOP is generated. Note that the interface will switch to Master Transmitter Mode if SMB0DAT is written while an active Master Receiver. Figure 16.9 shows a typical Master Receiver sequence. Two received data bytes are shown, though any number of bytes may be received. Notice that the 'data byte transferred' interrupts occur **before** the ACK cycle in this mode.

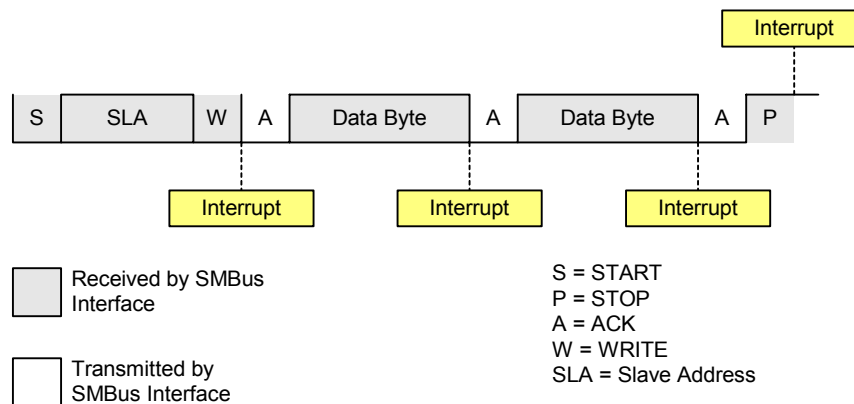
**Figure 16.9. Typical Master Receiver Sequence**



### 16.5.3. Slave Receiver Mode

Serial data is received on SDA and the clock is received on SCL. When slave events are enabled ( $INH = 0$ ), the interface enters Slave Receiver Mode when a START followed by a slave address and direction bit (WRITE in this case) is received. Upon entering Slave Receiver Mode, an interrupt is generated and the ACKRQ bit is set. Software responds to the received slave address with an ACK, or ignores the received slave address with a NACK. If the received slave address is ignored, slave interrupts will be inhibited until the next START is detected. If the received slave address is acknowledged, zero or more data bytes are received. Software must write the ACK bit after each received byte to ACK or NACK the received byte. The interface exits Slave Receiver Mode after receiving a STOP. Note that the interface will switch to Slave Transmitter Mode if SMB0DAT is written while an active Slave Receiver. Figure 16.10 shows a typical Slave Receiver sequence. Two received data bytes are shown, though any number of bytes may be received. Notice that the ‘data byte transferred’ interrupts occur **before** the ACK cycle in this mode.

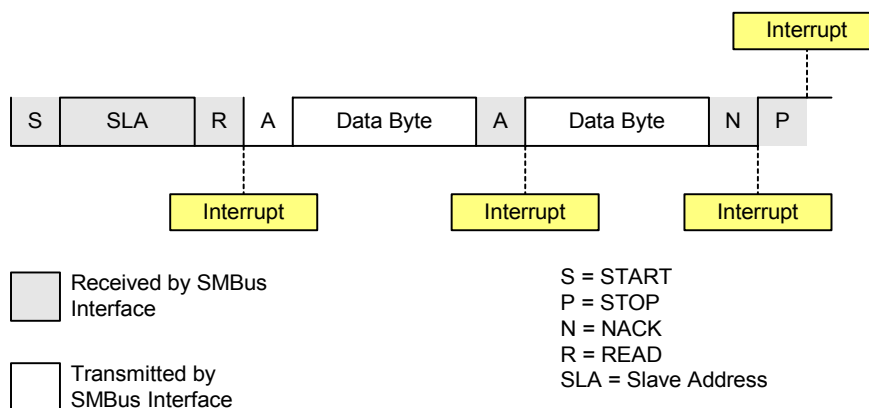
**Figure 16.10. Typical Slave Receiver Sequence**



## 16.5.4. Slave Transmitter Mode

Serial data is transmitted on SDA and the clock is received on SCL. When slave events are enabled (INH = 0), the interface enters Slave Receiver Mode (to receive the slave address) when a START followed by a slave address and direction bit (READ in this case) is received. Upon entering Slave Transmitter Mode, an interrupt is generated and the ACKRQ bit is set. Software responds to the received slave address with an ACK, or ignores the received slave address with a NACK. If the received slave address is ignored, slave interrupts will be inhibited until a START is detected. If the received slave address is acknowledged, data should be written to SMB0DAT to be transmitted. The interface enters Slave Transmitter Mode, and transmits one or more bytes of data. After each byte is transmitted, the master sends an acknowledge bit; if the acknowledge bit is an ACK, SMB0DAT should be written with the next data byte. If the acknowledge bit is a NACK, SMB0DAT should not be written to before SI is cleared (Note: an error condition may be generated if SMB0DAT is written following a received NACK while in Slave Transmitter Mode). The interface exits Slave Transmitter Mode after receiving a STOP. Note that the interface will switch to Slave Receiver Mode if SMB0DAT is not written following a Slave Transmitter interrupt. Figure 16.11 shows a typical Slave Transmitter sequence. Two transmitted data bytes are shown, though any number of bytes may be transmitted. Notice that the ‘data byte transferred’ interrupts occur **after** the ACK cycle in this mode.

**Figure 16.11. Typical Slave Transmitter Sequence**



## 16.6. SMBus Status Decoding

The current SMBus status can be easily decoded using the SMB0CN register. In the table below, STATUS VECTOR refers to the four upper bits of SMB0CN: MASTER, TXMODE, STA, and STO. Note that the shown response options are only the typical responses; application-specific procedures are allowed as long as they conform to the SMBus specification. Highlighted responses are allowed but do not conform to the SMBus specification.

**Table 16.4. SMBus Status Decoding**

MODE	VALUES READ			CURRENT SMBUS STATE	TYPICAL RESPONSE OPTIONS	VALUES WRITTEN			
	STATUS VECTOR	ACKRQ	ARBLOST			ACK	STA	STO	ACK
Master Transmitter	1110	0	0	X	A master START was generated.	Load slave address + R/W into SMB0DAT.	0	0	X
	1100	0	0	0	A master data or address byte was transmitted; NACK received.	Set STA to restart transfer.	1	0	X
						Abort transfer.	0	1	X
					A master data or address byte was transmitted; ACK received.	Load next data byte into SMB0DAT.	0	0	X
						End transfer with STOP.	0	1	X
						End transfer with STOP and start another transfer.	1	1	X
						Send repeated START.	1	0	X
Switch to Master Receiver Mode (clear SI without writing new data to SMB0DAT).	0	0	X						
Master Receiver	1000	1	0	X	A master data byte was received; ACK requested.	Acknowledge received byte; Read SMB0DAT.	0	0	1
						Send NACK to indicate last byte, and send STOP.	0	1	0
						Send NACK to indicate last byte, and send STOP followed by START.	1	1	0
						Send ACK followed by repeated START.	1	0	1
						Send NACK to indicate last byte, and send repeated START.	1	0	0
						Send ACK and switch to Master Transmitter Mode (write to SMB0DAT before clearing SI).	0	0	1
						Send NACK and switch to Master Transmitter Mode (write to SMB0DAT before clearing SI).	0	0	0

**Table 16.4. SMBus Status Decoding**

MODE	VALUES READ			CURRENT SMBUS STATE	TYPICAL RESPONSE OPTIONS	VALUES WRITTEN			
	STATUS VECTOR	ACKRQ	ARBLOST			ACK	STA	STO	ACK
Slave Transmitter	0100	0	0	0	A slave byte was transmitted; NACK received.	No action required (expecting STOP condition).	0	0	X
		0	0	1	A slave byte was transmitted; ACK received.	Load SMB0DAT with next data byte to transmit.	0	0	X
		0	1	X	A Slave byte was transmitted; error detected.	No action required (expecting Master to end transfer).	0	0	X
	0101	0	X	X	A STOP was detected while an addressed Slave Transmitter.	No action required (transfer complete).	0	0	X
Slave Receiver	0010	1	0	X	A slave address was received; ACK requested.	Acknowledge received address.	0	0	1
						Do not acknowledge received address.	0	0	0
		1	1	X	Lost arbitration as master; slave address received; ACK requested.	Acknowledge received address.	0	0	1
						Do not acknowledge received address.	0	0	0
	0010	0	1	X	Lost arbitration while attempting a repeated START.	Reschedule failed transfer; do not acknowledge received address.	1	0	0
						Abort failed transfer.	0	0	X
	0001	1	1	X	Lost arbitration while attempting a STOP.	Reschedule failed transfer.	1	0	X
						No action required (transfer complete/aborted).	0	0	0
						A STOP was detected while an addressed slave receiver.	0	0	X
		0	0	X	Lost arbitration due to a detected STOP.	Abort transfer.	0	0	X
						Reschedule failed transfer.	1	0	X
						No action required (transfer complete).	0	0	X
	0000	1	0	X	A slave byte was received; ACK requested.	Acknowledge received byte; Read SMB0DAT.	0	0	1
						Do not acknowledge received byte.	0	0	0
		1	1	X	Lost arbitration while transmitting a data byte as master.	Abort failed transfer.	0	0	0
						Reschedule failed transfer.	1	0	0



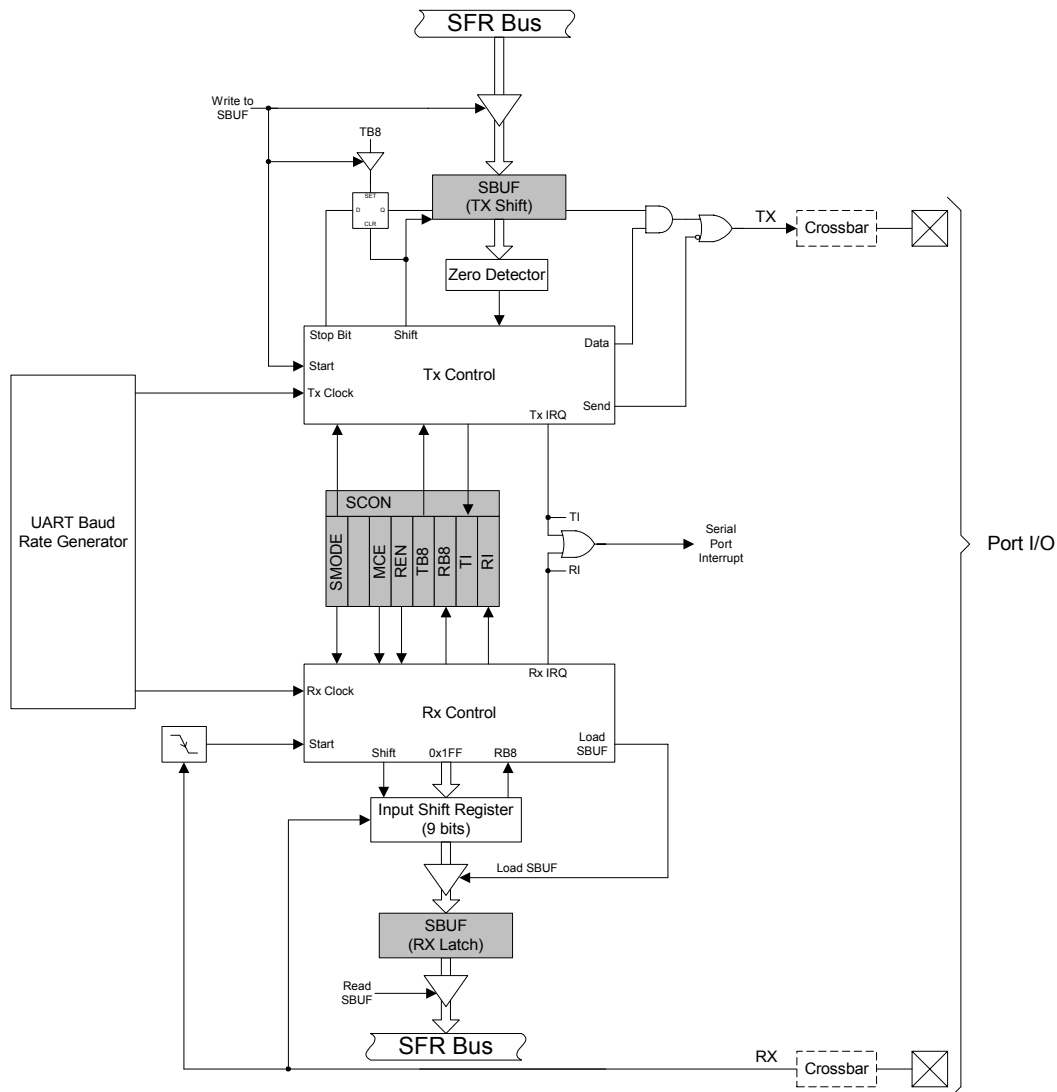
## 17. UART0

UART0 is an asynchronous, full duplex serial port offering modes 1 and 3 of the standard 8051 UART. Enhanced baud rate support allows a wide range of clock sources to generate standard baud rates (details in [Section “17.1. Enhanced Baud Rate Generation” on page 194](#)). Received data buffering allows UART0 to start reception of a second incoming data byte before software has finished reading the previous data byte.

UART0 has two associated SFRs: Serial Control Register 0 (SCON0) and Serial Data Buffer 0 (SBUF0). The single SBUF0 location provides access to both transmit and receive registers. **Writes to SBUF0 always access the Transmit register. Reads of SBUF0 always access the buffered Receive register; it is not possible to read data from the Transmit register.**

With UART0 interrupts enabled, an interrupt is generated each time a transmit is completed (TI0 is set in SCON0), or a data byte has been received (RI0 is set in SCON0). The UART0 interrupt flags are not cleared by hardware when the CPU vectors to the interrupt service routine. They must be cleared manually by software, allowing software to determine the cause of the UART0 interrupt (transmit complete or receive complete).

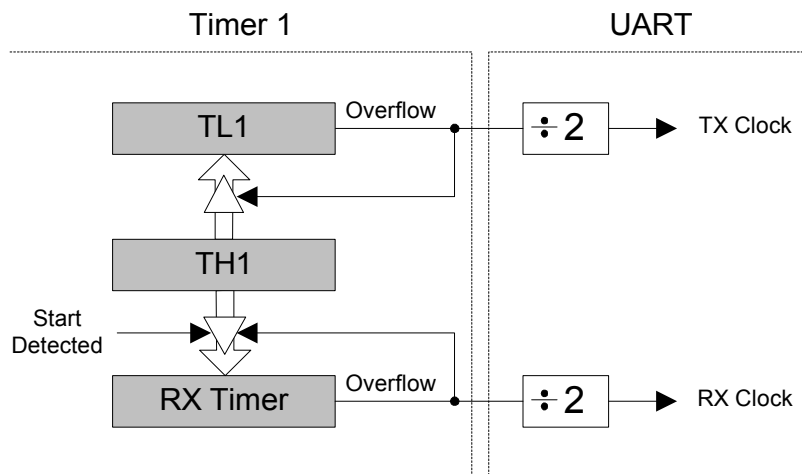
**Figure 17.1. UART0 Block Diagram**



## 17.1. Enhanced Baud Rate Generation

The UART0 baud rate is generated by Timer 1 in 8-bit auto-reload mode. The TX clock is generated by TL1; the RX clock is generated by a copy of TL1 (shown as RX Timer in Figure 17.2), which is not user-accessible. Both TX and RX Timer overflows are divided by two to generate the TX and RX baud rates. The RX Timer runs when Timer 1 is enabled, and uses the same reload value (TH1). However, an RX Timer reload is forced when a START condition is detected on the RX pin. This allows a receive to begin any time a START is detected, independent of the TX Timer state.

**Figure 17.2. UART0 Baud Rate Logic**



Timer 1 should be configured for Mode 2, 8-bit auto-reload (see [Section “19.1.3. Mode 2: 8-bit Counter/Timer with Auto-Reload” on page 219](#)). The Timer 1 reload value should be set so that overflows will occur at two times the desired UART baud rate frequency. Note that Timer 1 may be clocked by one of six sources: SYSCLK, SYSCLK / 4, SYSCLK / 12, SYSCLK / 48, the external oscillator clock / 8, or an external input T1. For any given Timer 1 clock source, the UART0 baud rate is determined by Equation 17.1.

### Equation 17.1. UART0 Baud Rate

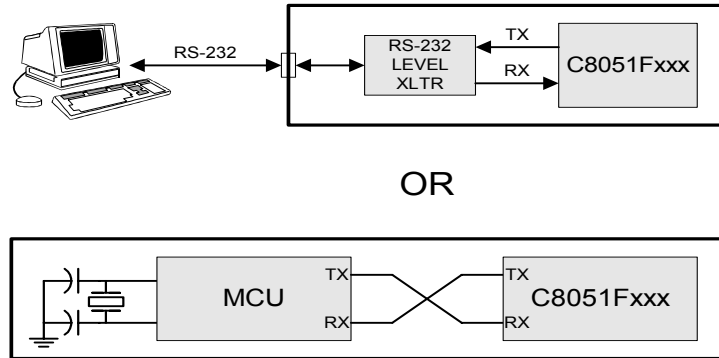
$$UartBaudRate = \frac{T1_{CLK}}{(256 - T1H)} \times \frac{1}{2}$$

Where  $T1_{CLK}$  is the frequency of the clock supplied to Timer 1, and  $T1H$  is the high byte of Timer 1 (reload value). Timer 1 clock frequency is selected as described in [Section “19. Timers” on page 217](#). A quick reference for typical baud rates and system clock frequencies is given in Table 17.1 through Table 17.6. Note that the internal oscillator may still generate the system clock when the external oscillator is driving Timer 1.

## 17.2. Operational Modes

UART0 provides standard asynchronous, full duplex communication. The UART mode (8-bit or 9-bit) is selected by the S0MODE bit (SCON0.7). Typical UART connection options are shown below.

**Figure 17.3. UART Interconnect Diagram**



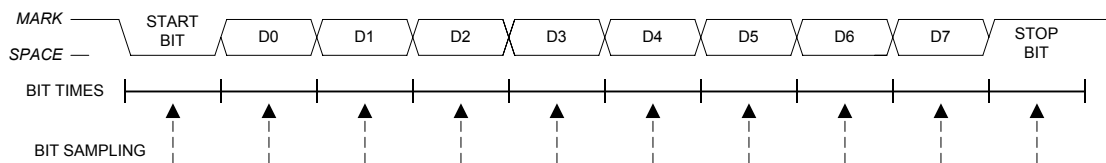
### 17.2.1. 8-Bit UART

8-Bit UART mode uses a total of 10 bits per data byte: one start bit, eight data bits (LSB first), and one stop bit. Data are transmitted LSB first from the TX0 pin and received at the RX0 pin. On receive, the eight data bits are stored in SBUF0 and the stop bit goes into RB80 (SCON0.2).

Data transmission begins when software writes a data byte to the SBUF0 register. The TI0 Transmit Interrupt Flag (SCON0.1) is set at the end of the transmission (the beginning of the stop-bit time). Data reception can begin any time after the REN0 Receive Enable bit (SCON0.4) is set to logic 1. After the stop bit is received, the data byte will be loaded into the SBUF0 receive register if the following conditions are met: RI0 must be logic 0, and if MCE0 is logic 1, the stop bit must be logic 1. In the event of a receive data overrun, the first received 8 bits are latched into the SBUF0 receive register and the following overrun data bits are lost.

If these conditions are met, the eight bits of data is stored in SBUF0, the stop bit is stored in RB80 and the RI0 flag is set. If these conditions are not met, SBUF0 and RB80 will not be loaded and the RI0 flag will not be set. An interrupt will occur if enabled when either TI0 or RI0 is set.

**Figure 17.4. 8-Bit UART Timing Diagram**

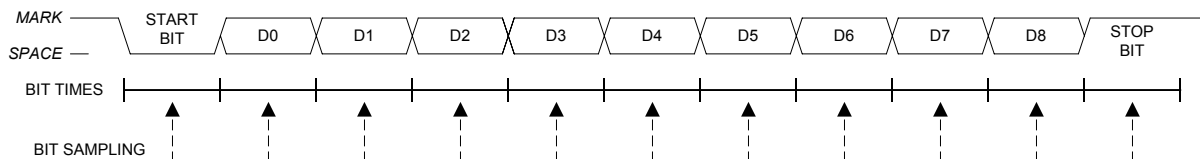


## 17.2.2. 9-Bit UART

9-bit UART mode uses a total of eleven bits per data byte: a start bit, 8 data bits (LSB first), a programmable ninth data bit, and a stop bit. The state of the ninth transmit data bit is determined by the value in TB80 (SCON0.3), which is assigned by user software. It can be assigned the value of the parity flag (bit P in register PSW) for error detection, or used in multiprocessor communications. On receive, the ninth data bit goes into RB80 (SCON0.2) and the stop bit is ignored.

Data transmission begins when an instruction writes a data byte to the SBUF0 register. The TI0 Transmit Interrupt Flag (SCON0.1) is set at the end of the transmission (the beginning of the stop-bit time). Data reception can begin any time after the RENO Receive Enable bit (SCON0.4) is set to '1'. After the stop bit is received, the data byte will be loaded into the SBUF0 receive register if the following conditions are met: (1) RI0 must be logic 0, and (2) if MCE0 is logic 1, the 9th bit must be logic 1 (when MCE0 is logic 0, the state of the ninth data bit is unimportant). If these conditions are met, the eight bits of data are stored in SBUF0, the ninth bit is stored in RB80, and the RI0 flag is set to '1'. If the above conditions are not met, SBUF0 and RB80 will not be loaded and the RI0 flag will not be set to '1'. A UART0 interrupt will occur if enabled when either TI0 or RI0 is set to '1'.

**Figure 17.5. 9-Bit UART Timing Diagram**



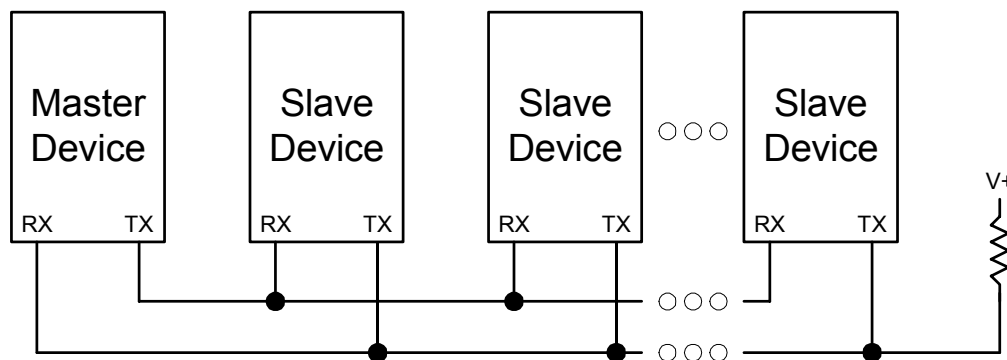
### 17.3. Multiprocessor Communications

9-Bit UART mode supports multiprocessor communication between a master processor and one or more slave processors by special use of the ninth data bit. When a master processor wants to transmit to one or more slaves, it first sends an address byte to select the target(s). An address byte differs from a data byte in that its ninth bit is logic 1; in a data byte, the ninth bit is always set to logic 0.

Setting the MCE0 bit (SCON0.5) of a slave processor configures its UART such that when a stop bit is received, the UART will generate an interrupt only if the ninth bit is logic 1 ( $RB80 = 1$ ) signifying an address byte has been received. In the UART interrupt handler, software will compare the received address with the slave's own assigned 8-bit address. If the addresses match, the slave will clear its MCE0 bit to enable interrupts on the reception of the following data byte(s). Slaves that weren't addressed leave their MCE0 bits set and do not generate interrupts on the reception of the following data bytes, thereby ignoring the data. Once the entire message is received, the addressed slave resets its MCE0 bit to ignore all transmissions until it receives the next address byte.

Multiple addresses can be assigned to a single slave and/or a single address can be assigned to multiple slaves, thereby enabling "broadcast" transmissions to more than one slave simultaneously. The master processor can be configured to receive all transmissions or a protocol can be implemented such that the master/slave role is temporarily reversed to enable half-duplex transmission between the original master and slave(s).

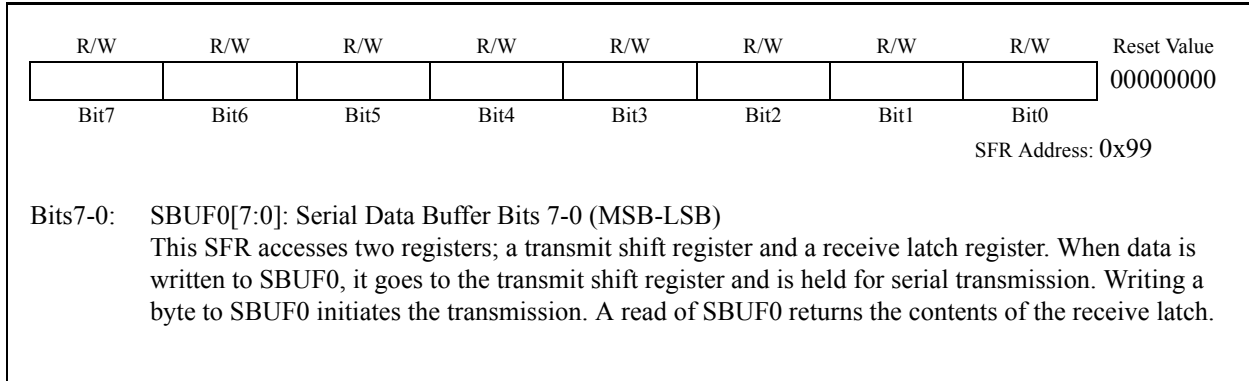
**Figure 17.6. UART Multi-Processor Mode Interconnect Diagram**



**Figure 17.7. SCON0: Serial Port 0 Control Register**

R/W	R	R/W	R/W	R/W	R/W	R/W	R/W	Reset Value
S0MODE	-	MCE0	REN0	TB80	RB80	TI0	RI0	01000000
Bit7	Bit6	Bit5	Bit4	Bit3	Bit2	Bit1	Bit0	Bit Addressable
								SFR Address: 0x98
Bit7:	S0MODE: Serial Port 0 Operation Mode. This bit selects the UART0 Operation Mode. 0: 8-bit UART with Variable Baud Rate. 1: 9-bit UART with Variable Baud Rate.							
Bit6:	UNUSED. Read = 1b. Write = don't care.							
Bit5:	MCE0: Multiprocessor Communication Enable. The function of this bit is dependent on the Serial Port 0 Operation Mode. S0MODE = 0: Checks for valid stop bit. 0: Logic level of stop bit is ignored. 1: RI0 will only be activated if stop bit is logic level 1. S0MODE = 1: Multiprocessor Communications Enable. 0: Logic level of ninth bit is ignored. 1: RI0 is set and an interrupt is generated only when the ninth bit is logic 1.							
Bit4:	REN0: Receive Enable. This bit enables/disables the UART receiver. 0: UART0 reception disabled. 1: UART0 reception enabled.							
Bit3:	TB80: Ninth Transmission Bit. The logic level of this bit will be assigned to the ninth transmission bit in 9-bit UART Mode. It is not used in 8-bit UART Mode. Set or cleared by software as required.							
Bit2:	RB80: Ninth Receive Bit. RB80 is assigned the value of the STOP bit in Mode 0; it is assigned the value of the 9th data bit in Mode 1.							
Bit1:	TI0: Transmit Interrupt Flag. Set by hardware when a byte of data has been transmitted by UART0 (after the 8th bit in 8-bit UART Mode, or at the beginning of the STOP bit in 9-bit UART Mode). When the UART0 interrupt is enabled, setting this bit causes the CPU to vector to the UART0 interrupt service routine. This bit must be cleared manually by software.							
Bit0:	RI0: Receive Interrupt Flag. Set to '1' by hardware when a byte of data has been received by UART0 (set at the STOP bit sampling time). When the UART0 interrupt is enabled, setting this bit to '1' causes the CPU to vector to the UART0 interrupt service routine. This bit must be cleared manually by software.							

**Figure 17.8. SBUF0: Serial (UART0) Port Data Buffer Register**



**Table 17.1. Timer Settings for Standard Baud Rates Using The Internal Oscillator**

Frequency: 24.5 MHz							
	Target Baud Rate (bps)	Baud Rate % Error	Oscillator Divide Factor	Timer Clock Source	SCA1-SCA0 (pre-scale select) <sup>†</sup>	T1M <sup>†</sup>	Timer 1 Reload Value (hex)
SYSCLK from Internal Osc.	230400	-0.32%	106	SYSCLK	XX	1	0xCB
	115200	-0.32%	212	SYSCLK	XX	1	0x96
	57600	0.15%	426	SYSCLK	XX	1	0x2B
	28800	-0.32%	848	SYSCLK / 4	01	0	0x96
	14400	0.15%	1704	SYSCLK / 12	00	0	0xB9
	9600	-0.32%	2544	SYSCLK / 12	00	0	0x96
	2400	-0.32%	10176	SYSCLK / 48	10	0	0x96
	1200	0.15%	20448	SYSCLK / 48	10	0	0x2B

X = Don't care

<sup>†</sup>SCA1-SCA0 and T1M bit definitions can be found in [Section 19.1](#).

**Table 17.2. Timer Settings for Standard Baud Rates Using an External Oscillator**

Frequency: 25.0 MHz							
	Target Baud Rate (bps)	Baud Rate % Error	Oscillator Divide Factor	Timer Clock Source	SCA1-SCA0 (pre-scale select) <sup>†</sup>	T1M <sup>†</sup>	Timer 1 Reload Value (hex)
SYSCLK from External Osc.	230400	-0.47%	108	SYSCLK	XX	1	0xCA
	115200	0.45%	218	SYSCLK	XX	1	0x93
	57600	-0.01%	434	SYSCLK	XX	1	0x27
	28800	0.45%	872	SYSCLK / 4	01	0	0x93
	14400	-0.01%	1736	SYSCLK / 4	01	0	0x27
	9600	0.15%	2608	EXTCLK / 8	11	0	0x5D
	2400	0.45%	10464	SYSCLK / 48	10	0	0x93
	1200	-0.01%	20832	SYSCLK / 48	10	0	0x27
SYSCLK from Internal Osc.	57600	-0.47%	432	EXTCLK / 8	11	0	0xE5
	28800	-0.47%	864	EXTCLK / 8	11	0	0xCA
	14400	0.45%	1744	EXTCLK / 8	11	0	0x93
	9600	0.15%	2608	EXTCLK / 8	11	0	0x5D

X = Don't care

<sup>†</sup>SCA1-SCA0 and T1M bit definitions can be found in [Section 19.1](#).



**Table 17.3. Timer Settings for Standard Baud Rates Using an External Oscillator**

Frequency: 22.1184 MHz							
	Target Baud Rate (bps)	Baud Rate % Error	Oscillator Divide Factor	Timer Clock Source	SCA1-SCA0 (pre-scale select) <sup>†</sup>	T1M <sup>†</sup>	Timer 1 Reload Value (hex)
SYSCLK from External Osc.	230400	0.00%	96	SYSCLK	XX	1	0xD0
	115200	0.00%	192	SYSCLK	XX	1	0xA0
	57600	0.00%	384	SYSCLK	XX	1	0x40
	28800	0.00%	768	SYSCLK / 12	00	0	0xE0
	14400	0.00%	1536	SYSCLK / 12	00	0	0xC0
	9600	0.00%	2304	SYSCLK / 12	00	0	0xA0
	2400	0.00%	9216	SYSCLK / 48	10	0	0xA0
	1200	0.00%	18432	SYSCLK / 48	10	0	0x40
SYSCLK from Internal Osc.	230400	0.00%	96	EXTCLK / 8	11	0	0xFA
	115200	0.00%	192	EXTCLK / 8	11	0	0xF4
	57600	0.00%	384	EXTCLK / 8	11	0	0xE8
	28800	0.00%	768	EXTCLK / 8	11	0	0xD0
	14400	0.00%	1536	EXTCLK / 8	11	0	0xA0
	9600	0.00%	2304	EXTCLK / 8	11	0	0x70

X = Don't care

<sup>†</sup>SCA1-SCA0 and T1M bit definitions can be found in [Section 19.1](#).

**Table 17.4. Timer Settings for Standard Baud Rates Using an External Oscillator**

Frequency: 18.432 MHz							
	Target Baud Rate (bps)	Baud Rate % Error	Oscillator Divide Factor	Timer Clock Source	SCA1-SCA0 (pre-scale select) <sup>†</sup>	T1M <sup>†</sup>	Timer 1 Reload Value (hex)
SYSCLK from External Osc.	230400	0.00%	80	SYSCLK	XX	1	0xD8
	115200	0.00%	160	SYSCLK	XX	1	0xB0
	57600	0.00%	320	SYSCLK	XX	1	0x60
	28800	0.00%	640	SYSCLK / 4	01	0	0xB0
	14400	0.00%	1280	SYSCLK / 4	01	0	0x60
	9600	0.00%	1920	SYSCLK / 12	00	0	0xB0
	2400	0.00%	7680	SYSCLK / 48	10	0	0xB0
	1200	0.00%	15360	SYSCLK / 48	10	0	0x60
SYSCLK from Internal Osc.	230400	0.00%	80	EXTCLK / 8	11	0	0xFB
	115200	0.00%	160	EXTCLK / 8	11	0	0xF6
	57600	0.00%	320	EXTCLK / 8	11	0	0xEC
	28800	0.00%	640	EXTCLK / 8	11	0	0xD8
	14400	0.00%	1280	EXTCLK / 8	11	0	0xB0
	9600	0.00%	1920	EXTCLK / 8	11	0	0x88

X = Don't care

<sup>†</sup>SCA1-SCA0 and T1M bit definitions can be found in [Section 19.1](#).

**Table 17.5. Timer Settings for Standard Baud Rates Using an External Oscillator**

Frequency: 11.0592 MHz							
	Target Baud Rate (bps)	Baud Rate % Error	Oscillator Divide Factor	Timer Clock Source	SCA1-SCA0 (pre-scale select) <sup>†</sup>	T1M <sup>†</sup>	Timer 1 Reload Value (hex)
SYSCLK from External Osc.	230400	0.00%	48	SYSCLK	XX	1	0xE8
	115200	0.00%	96	SYSCLK	XX	1	0xD0
	57600	0.00%	192	SYSCLK	XX	1	0xA0
	28800	0.00%	384	SYSCLK	XX	1	0x40
	14400	0.00%	768	SYSCLK / 12	00	0	0xE0
	9600	0.00%	1152	SYSCLK / 12	00	0	0xD0
	2400	0.00%	4608	SYSCLK / 12	00	0	0x40
	1200	0.00%	9216	SYSCLK / 48	10	0	0xA0
SYSCLK from Internal Osc.	230400	0.00%	48	EXTCLK / 8	11	0	0xFD
	115200	0.00%	96	EXTCLK / 8	11	0	0xFA
	57600	0.00%	192	EXTCLK / 8	11	0	0xF4
	28800	0.00%	384	EXTCLK / 8	11	0	0xE8
	14400	0.00%	768	EXTCLK / 8	11	0	0xD0
	9600	0.00%	1152	EXTCLK / 8	11	0	0xB8

X = Don't care

<sup>†</sup>SCA1-SCA0 and T1M bit definitions can be found in [Section 19.1](#).

**Table 17.6. Timer Settings for Standard Baud Rates Using an External Oscillator**

Frequency: 3.6864 MHz							
	Target Baud Rate (bps)	Baud Rate % Error	Oscillator Divide Factor	Timer Clock Source	SCA1-SCA0 (pre-scale select) <sup>†</sup>	T1M <sup>†</sup>	Timer 1 Reload Value (hex)
SYSCLK from External Osc.	230400	0.00%	16	SYSCLK	XX	1	0xF8
	115200	0.00%	32	SYSCLK	XX	1	0xF0
	57600	0.00%	64	SYSCLK	XX	1	0xE0
	28800	0.00%	128	SYSCLK	XX	1	0xC0
	14400	0.00%	256	SYSCLK	XX	1	0x80
	9600	0.00%	384	SYSCLK	XX	1	0x40
	2400	0.00%	1536	SYSCLK / 12	00	0	0xC0
	1200	0.00%	3072	SYSCLK / 12	00	0	0x80
SYSCLK from Internal Osc.	230400	0.00%	16	EXTCLK / 8	11	0	0xFF
	115200	0.00%	32	EXTCLK / 8	11	0	0xFE
	57600	0.00%	64	EXTCLK / 8	11	0	0xFC
	28800	0.00%	128	EXTCLK / 8	11	0	0xF8
	14400	0.00%	256	EXTCLK / 8	11	0	0xF0
	9600	0.00%	384	EXTCLK / 8	11	0	0xE8

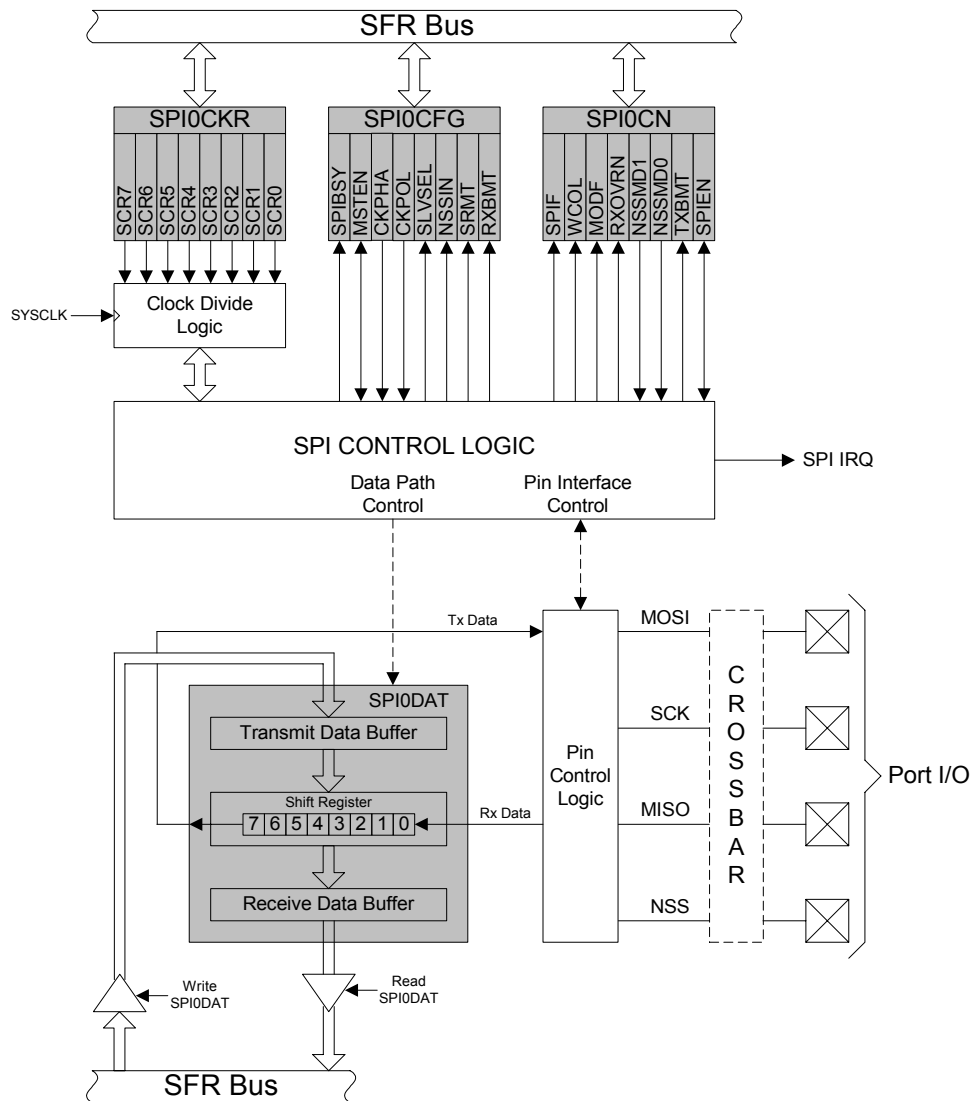
X = Don't care

<sup>†</sup>SCA1-SCA0 and T1M bit definitions can be found in [Section 19.1](#).

## 18. ENHANCED SERIAL PERIPHERAL INTERFACE (SPI0)

The Enhanced Serial Peripheral Interface (SPI0) provides access to a flexible, full-duplex synchronous serial bus. SPI0 can operate as a master or slave device in both 3-wire or 4-wire modes, and supports multiple masters and slaves on a single SPI bus. The slave-select (NSS) signal can be configured as an input to select SPI0 in slave mode, or to disable Master Mode operation in a multi-master environment, avoiding contention on the SPI bus when more than one master attempts simultaneous data transfers. NSS can also be configured as a chip-select output in master mode, or disabled for 3-wire operation. Additional general purpose port I/O pins can be used to select multiple slave devices in master mode.

Figure 18.1. SPI Block Diagram



## 18.1. Signal Descriptions

The four signals used by SPI0 (MOSI, MISO, SCK, NSS) are described below.

### 18.1.1. Master Out, Slave In (MOSI)

The master-out, slave-in (MOSI) signal is an output from a master device and an input to slave devices. It is used to serially transfer data from the master to the slave. This signal is an output when SPI0 is operating as a master and an input when SPI0 is operating as a slave. Data is transferred most-significant bit first. When configured as a master, MOSI is driven by the MSB of the shift register in both 3- and 4-wire mode.

### 18.1.2. Master In, Slave Out (MISO)

The master-in, slave-out (MISO) signal is an output from a slave device and an input to the master device. It is used to serially transfer data from the slave to the master. This signal is an input when SPI0 is operating as a master and an output when SPI0 is operating as a slave. Data is transferred most-significant bit first. The MISO pin is placed in a high-impedance state when the SPI module is disabled and when the SPI operates in 4-wire mode as a slave that is not selected. When acting as a slave in 3-wire mode, MISO is always driven by the MSB of the shift register.

### 18.1.3. Serial Clock (SCK)

The serial clock (SCK) signal is an output from the master device and an input to slave devices. It is used to synchronize the transfer of data between the master and slave on the MOSI and MISO lines. SPI0 generates this signal when operating as a master. The SCK signal is ignored by a SPI slave when the slave is not selected ( $NSS = 1$ ) in 4-wire slave mode.

### 18.1.4. Slave Select (NSS)

The function of the slave-select (NSS) signal is dependent on the setting of the NSSMD1 and NSSMD0 bits in the SPI0CN register. There are three possible modes that can be selected with these bits:

1. NSSMD[1:0] = 00: 3-Wire Master or 3-Wire Slave Mode: SPI0 operates in 3-wire mode, and NSS is disabled. When operating as a slave device, SPI0 is always selected in 3-wire mode. Since no select signal is present, SPI0 must be the only slave on the bus in 3-wire mode. This is intended for point-to-point communication between a master and one slave.
2. NSSMD[1:0] = 01: 4-Wire Slave or Multi-Master Mode: SPI0 operates in 4-wire mode, and NSS is enabled as an input. When operating as a slave, NSS selects the SPI0 device. When operating as a master, a 1-to-0 transition of the NSS signal disables the master function of SPI0 so that multiple master devices can be used on the same SPI bus.
3. NSSMD[1:0] = 1x: 4-Wire Master Mode: SPI0 operates in 4-wire mode, and NSS is enabled as an output. The setting of NSSMD0 determines what logic level the NSS pin will output. This configuration should only be used when operating SPI0 as a master device.

See Figure 18.2, Figure 18.3, and Figure 18.4 for typical connection diagrams of the various operational modes. **Note that the setting of NSSMD bits affects the pinout of the device.** When in 3-wire master or 3-wire slave mode, the NSS pin will not be mapped by the crossbar. In all other modes, the NSS signal will be mapped to a pin on the device. See Section “**14. Port Input/Output**” on page 127 for general purpose port I/O and crossbar information.

---

## 18.2. SPI0 Master Mode Operation

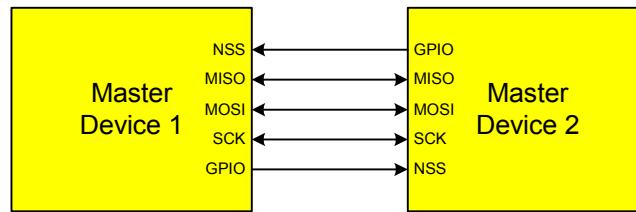
A SPI master device initiates all data transfers on a SPI bus. SPI0 is placed in master mode by setting the Master Enable flag (MSTEN, SPI0CN.6). Writing a byte of data to the SPI0 data register (SPI0DAT) when in master mode writes to the transmit buffer. If the SPI shift register is empty, the byte in the transmit buffer is moved to the shift register, and a data transfer begins. The SPI0 master immediately shifts out the data serially on the MOSI line while providing the serial clock on SCK. The SPIF (SPI0CN.7) flag is set to logic 1 at the end of the transfer. If interrupts are enabled, an interrupt request is generated when the SPIF flag is set. While the SPI0 master transfers data to a slave on the MOSI line, the addressed SPI slave device simultaneously transfers the contents of its shift register to the SPI master on the MISO line in a full-duplex operation. Therefore, the SPIF flag serves as both a transmit-complete and receive-data-ready flag. The data byte received from the slave is transferred MSB-first into the master's shift register. When a byte is fully shifted into the register, it is moved to the receive buffer where it can be read by the processor by reading SPI0DAT.

When configured as a master, SPI0 can operate in one of three different modes: multi-master mode, 3-wire single-master mode, and 4-wire single-master mode. The default, multi-master mode is active when NSSMD1 (SPI0CN.3) = 0 and NSSMD0 (SPI0CN.2) = 1. In this mode, NSS is an input to the device, and is used to disable the master SPI0 when another master is accessing the bus. When NSS is pulled low in this mode, MSTEN (SPI0CN.6) and SPIEN (SPI0CN.0) are set to 0 to disable the SPI master device, and a Mode Fault is generated (MODF, SPI0CN.5 = 1). Mode Fault will generate an interrupt if enabled. SPI0 must be manually re-enabled in software under these circumstances. In multi-master systems, devices will typically default to being slave devices while they are not acting as the system master device. In multi-master mode, slave devices can be addressed individually (if needed) using general-purpose I/O pins. Figure 18.2 shows a connection diagram between two master devices in multiple-master mode.

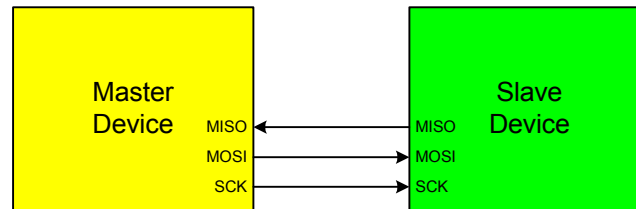
3-wire single-master mode is active when NSSMD1 (SPI0CN.3) = 0 and NSSMD0 (SPI0CN.2) = 0. In this mode, NSS is not used, and is not mapped to an external port pin through the crossbar. Any slave devices that must be addressed in this mode should be selected using general-purpose I/O pins. Figure 18.3 shows a connection diagram between a master device in 3-wire master mode and a slave device.

4-wire single-master mode is active when NSSMD1 (SPI0CN.3) = 1. In this mode, NSS is configured as an output pin, and can be used as a slave-select signal for a single SPI device. In this mode, the output value of NSS is controlled (in software) with the bit NSSMD0 (SPI0CN.2). Additional slave devices can be addressed using general-purpose I/O pins. Figure 18.4 shows a connection diagram for a master device in 4-wire master mode and two slave devices.

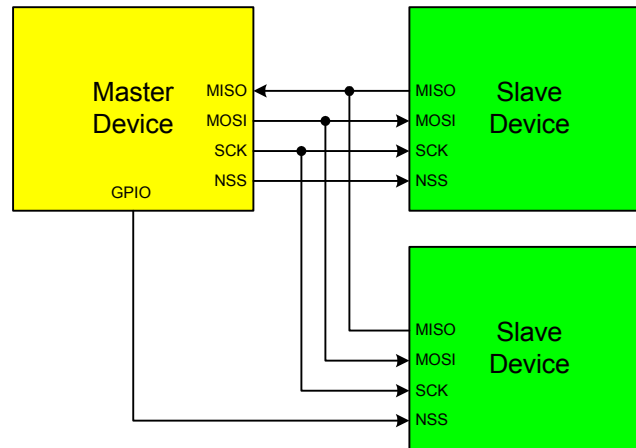
**Figure 18.2. Multiple-Master Mode Connection Diagram**



**Figure 18.3. 3-Wire Single Master and 3-Wire Single Slave Mode Connection Diagram**



**Figure 18.4. 4-Wire Single Master Mode and 4-Wire Slave Mode Connection Diagram**



## 18.3. SPI0 Slave Mode Operation

When SPI0 is enabled and not configured as a master, it will operate as a SPI slave. As a slave, bytes are shifted in through the MOSI pin and out through the MISO pin by a master device controlling the SCK signal. A bit counter in the SPI0 logic counts SCK edges. When 8 bits have been shifted through the shift register, the SPIF flag is set to logic 1, and the byte is copied into the receive buffer. Data is read from the receive buffer by reading SPI0DAT. A slave device cannot initiate transfers. Data to be transferred to the master device is pre-loaded into the shift register by writing to SPI0DAT. Writes to SPI0DAT are double-buffered, and are placed in the transmit buffer first. If the shift register is empty, the contents of the transmit buffer will immediately be transferred into the shift register. When the shift register already contains data, the SPI will load the shift register with the transmit buffer's contents after the last SCK edge of the next (or current) SPI transfer.

When configured as a slave, SPI0 can be configured for 4-wire or 3-wire operation. The default, 4-wire slave mode, is active when NSSMD1 (SPI0CN.3) = 0 and NSSMD0 (SPI0CN.2) = 1. In 4-wire mode, the NSS signal is routed to a port pin and configured as a digital input. SPI0 is enabled when NSS is logic 0, and disabled when NSS is logic 1. The bit counter is reset on a falling edge of NSS. Note that the NSS signal must be driven low at least 2 system clocks before the first active edge of SCK for each byte transfer. Figure 18.4 shows a connection diagram between two slave devices in 4-wire slave mode and a master device.

3-wire slave mode is active when NSSMD1 (SPI0CN.3) = 0 and NSSMD0 (SPI0CN.2) = 0. NSS is not used in this mode, and is not mapped to an external port pin through the crossbar. Since there is no way of uniquely addressing the device in 3-wire slave mode, SPI0 must be the only slave device present on the bus. It is important to note that in 3-wire slave mode there is no external means of resetting the bit counter that determines when a full byte has been received. The bit counter can only be reset by disabling and re-enabling SPI0 with the SPIEN bit. Figure 18.3 shows a connection diagram between a slave device in 3-wire slave mode and a master device.

## 18.4. SPI0 Interrupt Sources

When SPI0 interrupts are enabled, the following four flags will generate an interrupt when they are set to logic 1:

*Note that all of the following bits must be cleared by software.*

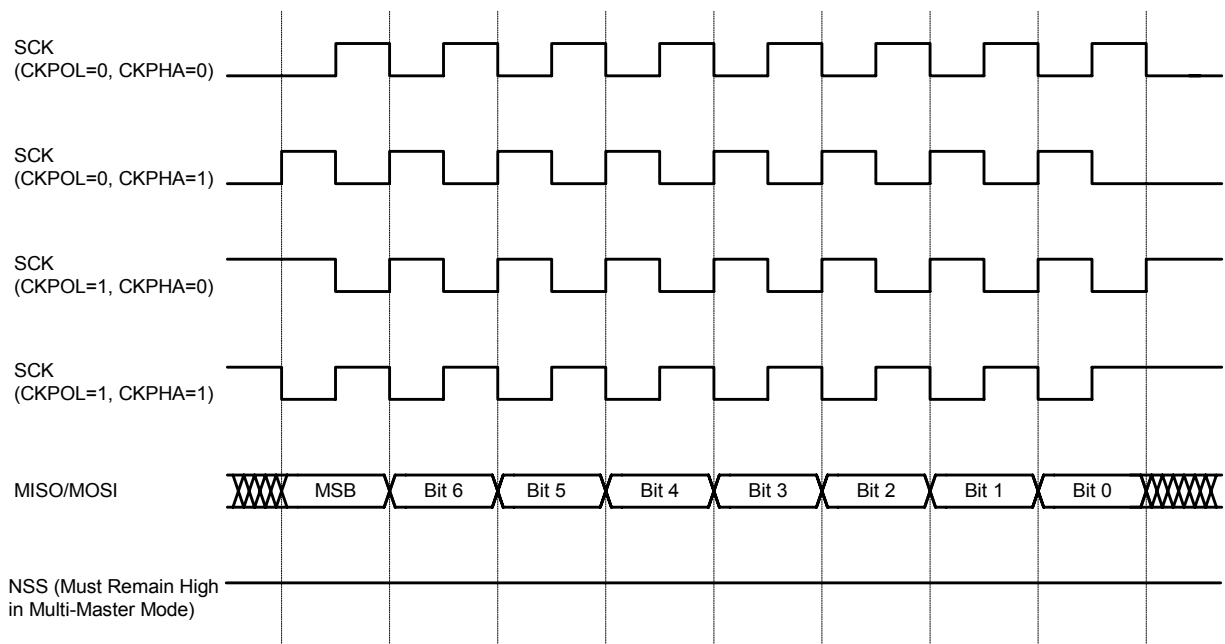
1. The SPI Interrupt Flag, SPIF (SPI0CN.7) is set to logic 1 at the end of each byte transfer. This flag can occur in all SPI0 modes.
2. The Write Collision Flag, WCOL (SPI0CN.6) is set to logic 1 if a write to SPI0DAT is attempted when the transmit buffer has not been emptied to the SPI shift register. When this occurs, the write to SPI0DAT will be ignored, and the transmit buffer will not be written. This flag can occur in all SPI0 modes.
3. The Mode Fault Flag MODF (SPI0CN.5) is set to logic 1 when SPI0 is configured as a master, and for multi-master mode and the NSS pin is pulled low. When a Mode Fault occurs, the MSTEN and SPIEN bits in SPI0CN are set to logic 0 to disable SPI0 and allow another master device to access the bus.
4. The Receive Overrun Flag RXOVRN (SPI0CN.4) is set to logic 1 when configured as a slave, and a transfer is completed and the receive buffer still holds an unread byte from a previous transfer. The new byte is not transferred to the receive buffer, allowing the previously received data byte to be read. The data byte which caused the overrun is lost.

## 18.5. Serial Clock Timing

Four combinations of serial clock phase and polarity can be selected using the clock control bits in the SPI0 Configuration Register (SPI0CFG). The CKPHA bit (SPI0CFG.5) selects one of two clock phases (edge used to latch the data). The CKPOL bit (SPI0CFG.4) selects between an active-high or active-low clock. Both master and slave devices must be configured to use the same clock phase and polarity. SPI0 should be disabled (by clearing the SPIEN bit, SPI0CN.0) when changing the clock phase or polarity. The clock and data line relationships for master mode are shown in Figure 18.5. For slave mode, the clock and data relationships are shown in Figure 18.6 and Figure 18.7. Note that CKPHA must be set to '0' on both the master and slave SPI when communicating between two of the following devices: C8051F04x, C8051F06x, C8051F12x, C8051F31x, C8051F32x, and C8051F33x

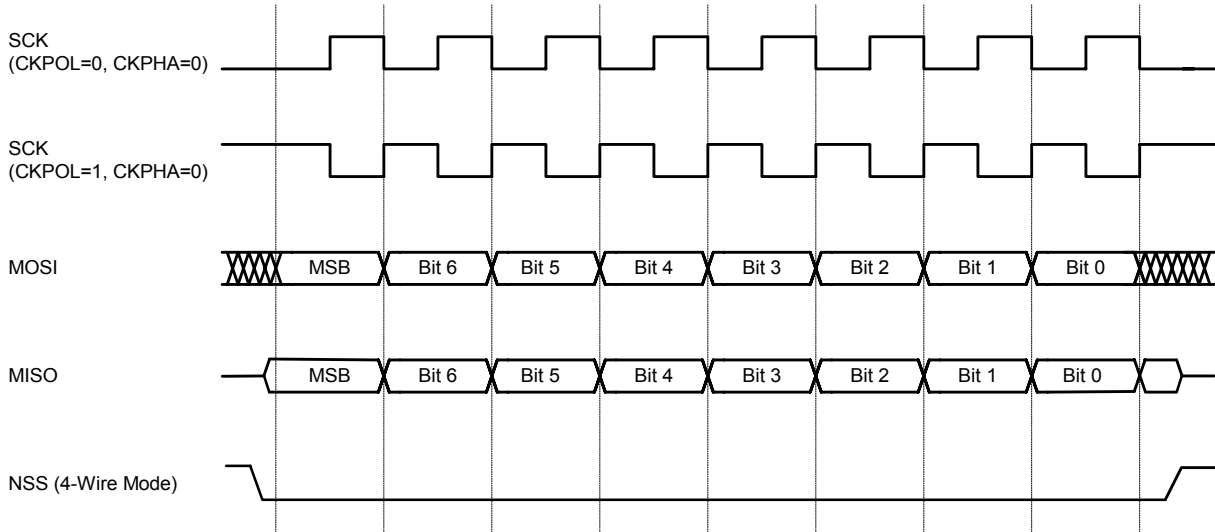
The SPI0 Clock Rate Register (SPI0CKR) as shown in Figure 18.10 controls the master mode serial clock frequency. This register is ignored when operating in slave mode. When the SPI is configured as a master, the maximum data transfer rate (bits/sec) is one-half the system clock frequency or 12.5 MHz, whichever is slower. When the SPI is configured as a slave, the maximum data transfer rate (bits/sec) for full-duplex operation is 1/10 the system clock frequency, provided that the master issues SCK, NSS (in 4-wire slave mode), and the serial input data synchronously with the slave's system clock. If the master issues SCK, NSS, and the serial input data asynchronously, the maximum data transfer rate (bits/sec) must be less than 1/10 the system clock frequency. In the special case where the master only wants to transmit data to the slave and does not need to receive data from the slave (i.e. half-duplex operation), the SPI slave can receive data at a maximum data transfer rate (bits/sec) of 1/4 the system clock frequency. This is provided that the master issues SCK, NSS, and the serial input data synchronously with the slave's system clock.

**Figure 18.5. Master Mode Data/Clock Timing**

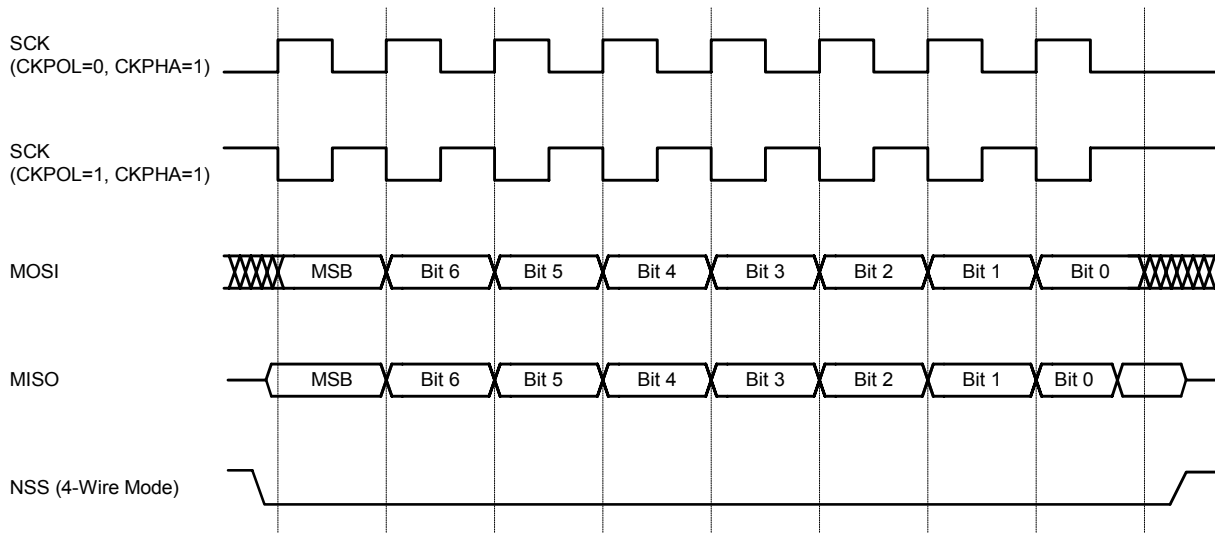




**Figure 18.6. Slave Mode Data/Clock Timing (CKPHA = 0)**



**Figure 18.7. Slave Mode Data/Clock Timing (CKPHA = 1)**



## 18.6. SPI Special Function Registers

SPI0 is accessed and controlled through four special function registers in the system controller: SPI0CN Control Register, SPI0DAT Data Register, SPI0CFG Configuration Register, and SPI0CKR Clock Rate Register. The four special function registers related to the operation of the SPI0 Bus are described in the following figures.

**Figure 18.8. SPI0CFG: SPI0 Configuration Register**

R	R/W	R/W	R/W	R	R	R	R	Reset Value
SPIBSY	MSTEN	CKPHA	CKPOL	SLVSEL	NSSIN	SRMT	RXBMT	00000111
Bit7	Bit6	Bit5	Bit4	Bit3	Bit2	Bit1	Bit0	

SFR Address: 0xA1

Bit 7: SPIBSY: SPI Busy (read only).  
This bit is set to logic 1 when a SPI transfer is in progress (Master or slave Mode).

Bit 6: MSTEN: Master Mode Enable.  
0: Disable master mode. Operate in slave mode.  
1: Enable master mode. Operate as a master.

Bit 5: CKPHA: SPI0 Clock Phase.  
This bit controls the SPI0 clock phase.  
0: Data centered on first edge of SCK period.<sup>†</sup>  
1: Data centered on second edge of SCK period.<sup>†</sup>

Bit 4: CKPOL: SPI0 Clock Polarity.  
This bit controls the SPI0 clock polarity.  
0: SCK line low in idle state.  
1: SCK line high in idle state.

Bit 3: SLVSEL: Slave Selected Flag (read only).  
This bit is set to logic 1 whenever the NSS pin is low indicating SPI0 is the selected slave. It is cleared to logic 0 when NSS is high (slave not selected). This bit does not indicate the instantaneous value at the NSS pin, but rather a de-glitched version of the pin input.

Bit 2: NSSIN: NSS Instantaneous Pin Input (read only).  
This bit mimics the instantaneous value that is present on the NSS port pin at the time that the register is read. This input is not de-glitched.

Bit 1: SRMT: Shift Register Empty (Valid in Slave Mode, read only).  
This bit will be set to logic 1 when all data has been transferred in/out of the shift register, and there is no new information available to read from the transmit buffer or write to the receive buffer. It returns to logic 0 when a data byte is transferred to the shift register from the transmit buffer or by a transition on SCK.  
NOTE: SRMT = 1 when in Master Mode.

Bit 0: RXBMT: Receive Buffer Empty (Valid in Slave Mode, read only).  
This bit will be set to logic 1 when the receive buffer has been read and contains no new information. If there is new information available in the receive buffer that has not been read, this bit will return to logic 0.  
NOTE: RXBMT = 1 when in Master Mode.

<sup>†</sup>In slave mode, data on MOSI is sampled in the center of each data bit. In master mode, data on MISO is sampled one SYSCLK before the end of each data bit, to provide maximum settling time for the slave device. See Table 18.1 for timing parameters.

Figure 18.9. SPI0CN: SPI0 Control Register

R/W	R/W	R/W	R/W	R/W	R/W	R	R/W	Reset Value
SPIF	WCOL	MODF	RXOVRN	NSSMD1	NSSMD0	TXBMT	SPIEN	00000110
Bit7	Bit6	Bit5	Bit4	Bit3	Bit2	Bit1	Bit0	Bit Addressable
SFR Address: 0xF8								
Bit 7:	SPIF: SPI0 Interrupt Flag. This bit is set to logic 1 by hardware at the end of a data transfer. If interrupts are enabled, setting this bit causes the CPU to vector to the SPI0 interrupt service routine. This bit is not automatically cleared by hardware. It must be cleared by software.							
Bit 6:	WCOL: Write Collision Flag. This bit is set to logic 1 by hardware (and generates a SPI0 interrupt) to indicate a write to the SPI0 data register was attempted while a data transfer was in progress. It must be cleared by software.							
Bit 5:	MODF: Mode Fault Flag. This bit is set to logic 1 by hardware (and generates a SPI0 interrupt) when a master mode collision is detected (NSS is low, MSTEN = 1, and NSSMD[1:0] = 01). This bit is not automatically cleared by hardware. It must be cleared by software.							
Bit 4:	RXOVRN: Receive Overrun Flag (Slave Mode only). This bit is set to logic 1 by hardware (and generates a SPI0 interrupt) when the receive buffer still holds unread data from a previous transfer and the last bit of the current transfer is shifted into the SPI0 shift register. This bit is not automatically cleared by hardware. It must be cleared by software.							
Bits 3-2:	NSSMD1-NSSMD0: Slave Select Mode. Selects between the following NSS operation modes: (See <a href="#">Section “18.2. SPI0 Master Mode Operation” on page 205</a> and <a href="#">Section “18.3. SPI0 Slave Mode Operation” on page 207</a> ). 00: 3-Wire Slave or 3-wire Master Mode. NSS signal is not routed to a port pin. 01: 4-Wire Slave or Multi-Master Mode (Default). NSS is always an input to the device. 1x: 4-Wire Single-Master Mode. NSS signal is mapped as an output from the device and will assume the value of NSSMD0.							
Bit 1:	TXBMT: Transmit Buffer Empty. This bit will be set to logic 0 when new data has been written to the transmit buffer. When data in the transmit buffer is transferred to the SPI shift register, this bit will be set to logic 1, indicating that it is safe to write a new byte to the transmit buffer.							
Bit 0:	SPIEN: SPI0 Enable. This bit enables/disables the SPI. 0: SPI disabled. 1: SPI enabled.							

**Figure 18.10. SPI0CKR: SPI0 Clock Rate Register**

R/W	R/W	R/W	R/W	R/W	R/W	R/W	R/W	Reset Value
SCR7	SCR6	SCR5	SCR4	SCR3	SCR2	SCR1	SCR0	00000000
Bit7	Bit6	Bit5	Bit4	Bit3	Bit2	Bit1	Bit0	

SFR Address: 0xA2

Bits 7-0: SCR7-SCR0: SPI0 Clock Rate.  
 These bits determine the frequency of the SCK output when the SPI0 module is configured for master mode operation. The SCK clock frequency is a divided version of the system clock, and is given in the following equation, where *SYSCLK* is the system clock frequency and *SPI0CKR* is the 8-bit value held in the SPI0CKR register.

$$f_{SCK} = \frac{SYSCLK}{2 \times (SPI0CKR + 1)}$$

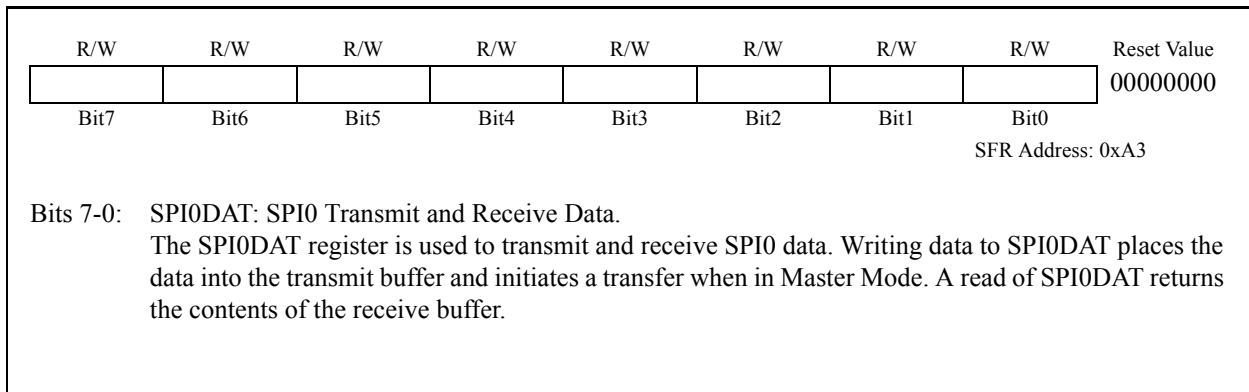
for  $0 \leq SPI0CKR \leq 255$

Example: If *SYSCLK* = 2 MHz and *SPI0CKR* = 0x04,

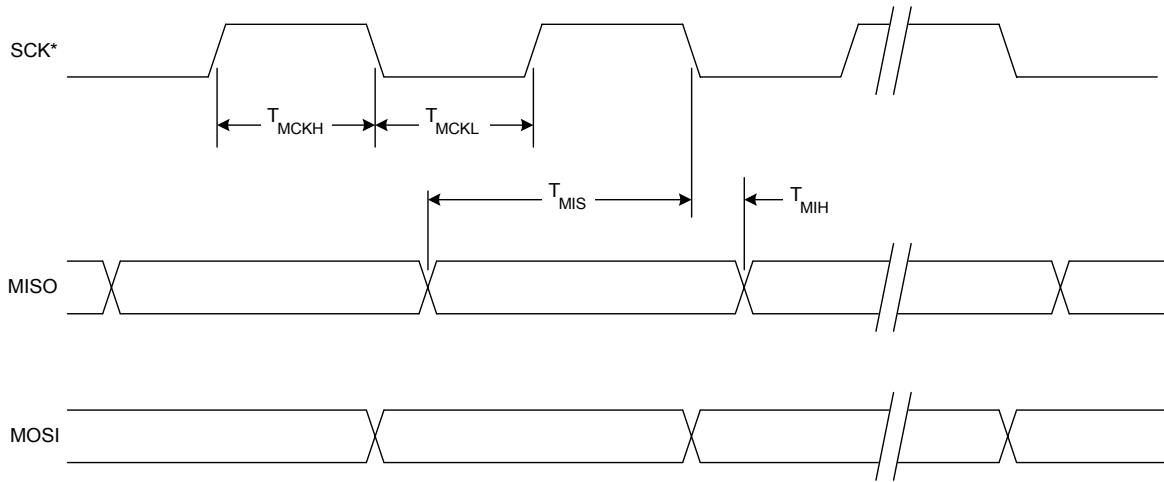
$$f_{SCK} = \frac{2000000}{2 \times (4 + 1)}$$

$$f_{SCK} = 200kHz$$

**Figure 18.11. SPI0DAT: SPI0 Data Register**

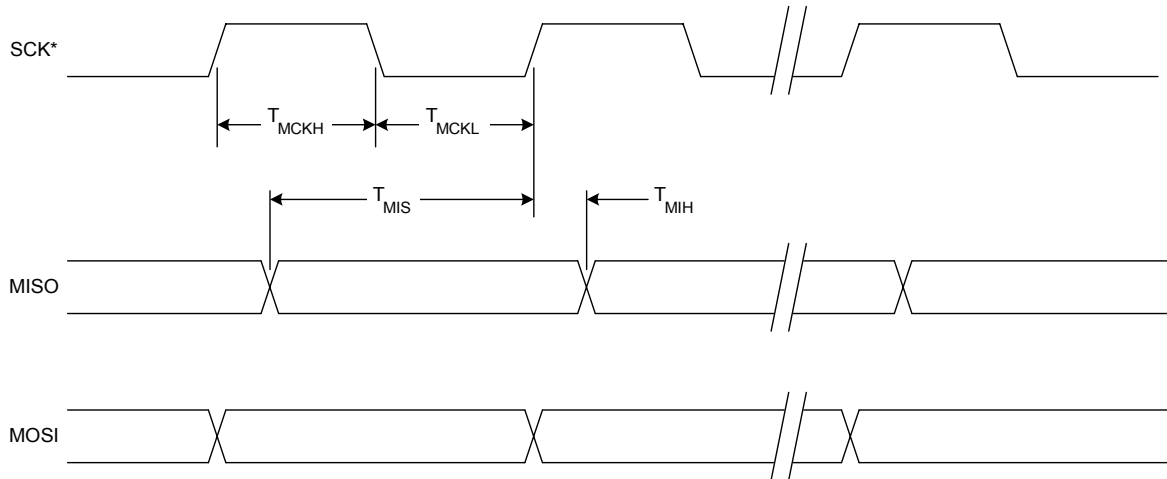


**Figure 18.12. SPI Master Timing (CKPHA = 0)**



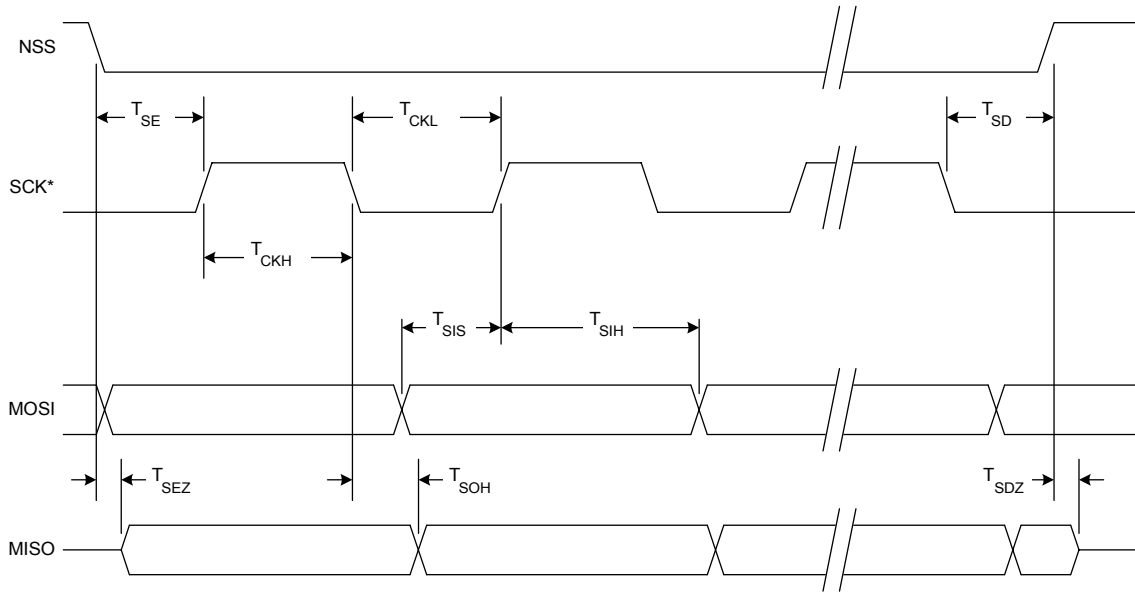
\* SCK is shown for CKPOL = 0. SCK is the opposite polarity for CKPOL = 1.

**Figure 18.13. SPI Master Timing (CKPHA = 1)**



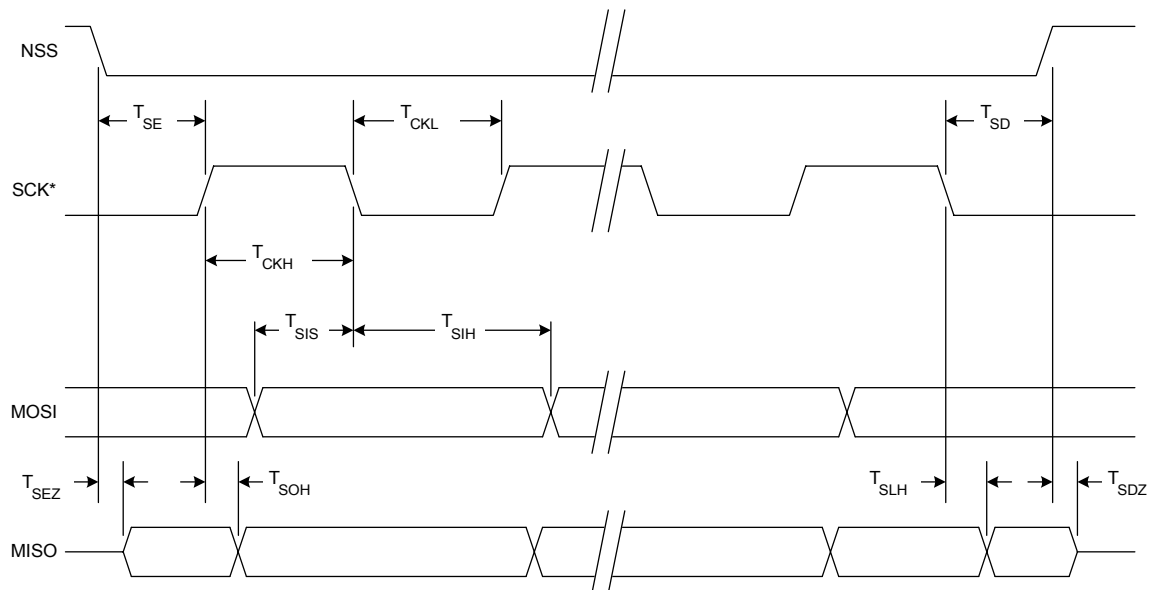
\* SCK is shown for CKPOL = 0. SCK is the opposite polarity for CKPOL = 1.

**Figure 18.14. SPI Slave Timing (CKPHA = 0)**



\* SCK is shown for CKPOL = 0. SCK is the opposite polarity for CKPOL = 1.

**Figure 18.15. SPI Slave Timing (CKPHA = 1)**



\* SCK is shown for CKPOL = 0. SCK is the opposite polarity for CKPOL = 1.

**Table 18.1. SPI Slave Timing Parameters**

PARAMETER	DESCRIPTION	MIN	MAX	UNITS
<b>MASTER MODE TIMING</b> <sup>†</sup> (See Figure 18.12 and Figure 18.13)				
<b>T<sub>MCKH</sub></b>	SCK High Time	1*T <sub>SYSClk</sub>		ns
<b>T<sub>MCKL</sub></b>	SCK Low Time	1*T <sub>SYSClk</sub>		ns
<b>T<sub>MIS</sub></b>	MISO Valid to SCK Shift Edge	1*T <sub>SYSClk</sub> + 20		ns
<b>T<sub>MIH</sub></b>	SCK Shift Edge to MISO Change	0		ns
<b>SLAVE MODE TIMING</b> <sup>†</sup> (See Figure 18.14 and Figure 18.15)				
<b>T<sub>SE</sub></b>	NSS Falling to First SCK Edge	2*T <sub>SYSClk</sub>		ns
<b>T<sub>SD</sub></b>	Last SCK Edge to NSS Rising	2*T <sub>SYSClk</sub>		ns
<b>T<sub>SEZ</sub></b>	NSS Falling to MISO Valid		4*T <sub>SYSClk</sub>	ns
<b>T<sub>SDZ</sub></b>	NSS Rising to MISO High-Z		4*T <sub>SYSClk</sub>	ns
<b>T<sub>CKH</sub></b>	SCK High Time	5*T <sub>SYSClk</sub>		ns
<b>T<sub>CKL</sub></b>	SCK Low Time	5*T <sub>SYSClk</sub>		ns
<b>T<sub>SIS</sub></b>	MOSI Valid to SCK Sample Edge	2*T <sub>SYSClk</sub>		ns
<b>T<sub>SIH</sub></b>	SCK Sample Edge to MOSI Change	2*T <sub>SYSClk</sub>		ns
<b>T<sub>SOH</sub></b>	SCK Shift Edge to MISO Change		4*T <sub>SYSClk</sub>	ns
<b>T<sub>SLH</sub></b>	Last SCK Edge to MISO Change (CKPHA = 1 ONLY)	6*T <sub>SYSClk</sub>	8*T <sub>SYSClk</sub>	ns
<sup>†</sup> T <sub>SYSClk</sub> is equal to one period of the device system clock (SYSClk).				



## 19. TIMERS

Each MCU includes four counter/timers: two are 16-bit counter/timers compatible with those found in the standard 8051, and two are 16-bit auto-reload timer for use with the ADC, SMBus, USB (frame measurements), or for general purpose use. These timers can be used to measure time intervals, count external events and generate periodic interrupt requests. Timer 0 and Timer 1 are nearly identical and have four primary modes of operation. Timer 2 and Timer 3 offer 16-bit and split 8-bit timer functionality with auto-reload.

Timer 0 and Timer 1 Modes:	Timer 2 Modes:	Timer 3 Modes:
13-bit counter/timer	16-bit timer with auto-reload	16-bit timer with auto-reload
16-bit counter/timer		
8-bit counter/timer with auto-reload	Two 8-bit timers with auto-reload	Two 8-bit timers with auto-reload
Two 8-bit counter/timers (Timer 0 only)		

Timers 0 and 1 may be clocked by one of five sources, determined by the Timer Mode Select bits (T1M-T0M) and the Clock Scale bits (SCA1-SCA0). The Clock Scale bits define a pre-scaled clock from which Timer 0 and/or Timer 1 may be clocked (See Figure 19.6 for pre-scaled clock selection).

Timer 0/1 may then be configured to use this pre-scaled clock signal or the system clock. Timer 2 and Timer 3 may be clocked by the system clock, the system clock divided by 12, or the external oscillator clock source divided by 8.

Timer 0 and Timer 1 may also be operated as counters. When functioning as a counter, a counter/timer register is incremented on each high-to-low transition at the selected input pin (T0 or T1). Events with a frequency of up to one-fourth the system clock's frequency can be counted. The input signal need not be periodic, but it should be held at a given level for at least two full system clock cycles to ensure the level is properly sampled.

### 19.1. Timer 0 and Timer 1

Each timer is implemented as a 16-bit register accessed as two separate bytes: a low byte (TL0 or TL1) and a high byte (TH0 or TH1). The Counter/Timer Control register (TCON) is used to enable Timer 0 and Timer 1 as well as indicate status. Timer 0 interrupts can be enabled by setting the ET0 bit in the IE register (**Section "8.3.5. Interrupt Register Descriptions" on page 61**); Timer 1 interrupts can be enabled by setting the ET1 bit in the IE register (**Section 8.3.5**). Both counter/timers operate in one of four primary modes selected by setting the Mode Select bits T1M1-T0M0 in the Counter/Timer Mode register (TMOD). Each timer can be configured independently. Each operating mode is described below.

#### 19.1.1. Mode 0: 13-bit Counter/Timer

Timer 0 and Timer 1 operate as 13-bit counter/timers in Mode 0. The following describes the configuration and operation of Timer 0. However, both timers operate identically, and Timer 1 is configured in the same manner as described for Timer 0.

The TH0 register holds the eight MSBs of the 13-bit counter/timer. TL0 holds the five LSBs in bit positions TL0.4-TL0.0. The three upper bits of TL0 (TL0.7-TL0.5) are indeterminate and should be masked out or ignored when reading. As the 13-bit timer register increments and overflows from 0x1FFF (all ones) to 0x0000, the timer overflow flag TF0 (TCON.5) is set and an interrupt will occur if Timer 0 interrupts are enabled.

The C/T0 bit (TMOD.2) selects the counter/timer's clock source. When C/T0 is set to logic 1, high-to-low transitions at the selected Timer 0 input pin (T0) increment the timer register (Refer to **Section "14.1. Priority Crossbar Decoder" on page 129** for information on selecting and configuring external I/O pins). Clearing C/T selects the clock defined by the T0M bit (CKCON.3). When T0M is set, Timer 0 is clocked by the system clock. When T0M is cleared, Timer 0 is clocked by the source selected by the Clock Scale bits in CKCON (see Figure 19.6).

# C8051F320/1

Setting the TR0 bit (TCON.4) enables the timer when either GATE0 (TMOD.3) is logic 0 or the input signal /INT0 is active as defined by bit IN0PL in register INT01CF (see Figure 8.13). Setting GATE0 to '1' allows the timer to be controlled by the external input signal /INT0 (see **Section “8.3.5. Interrupt Register Descriptions” on page 61**), facilitating pulse width measurements.

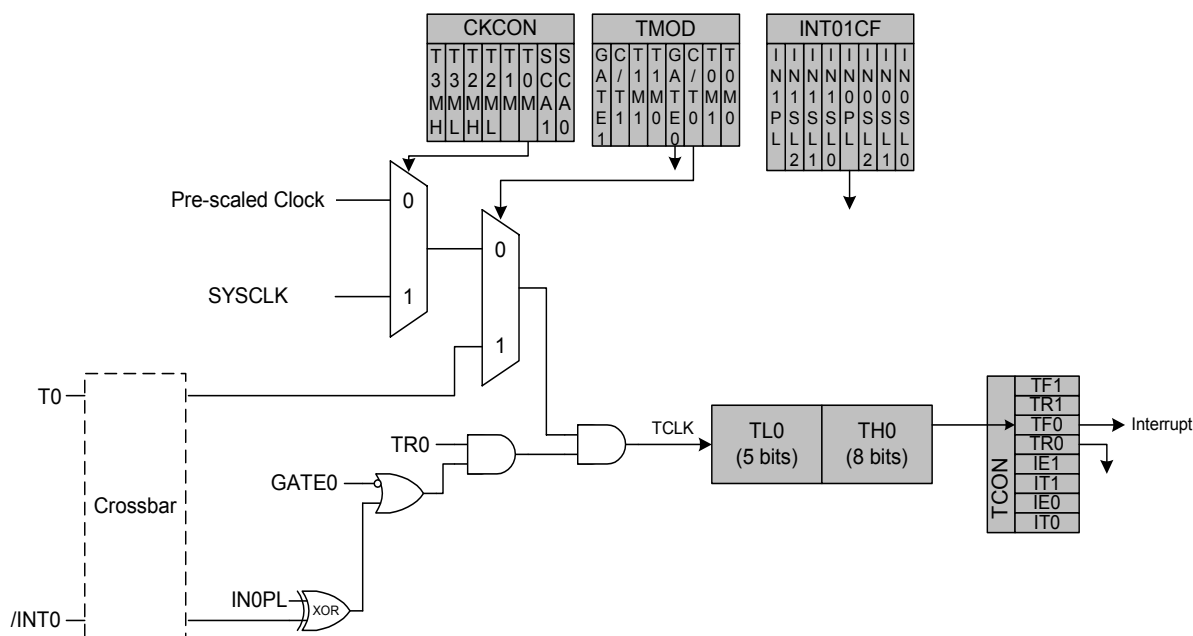
TR0	GATE0	/INT0	Counter/Timer
0	X	X	Disabled
1	0	X	Enabled
1	1	0	Disabled
1	1	1	Enabled

X = Don't Care

Setting TR0 does not force the timer to reset. The timer registers should be loaded with the desired initial value before the timer is enabled.

TL1 and TH1 form the 13-bit register for Timer 1 in the same manner as described above for TL0 and TH0. Timer 1 is configured and controlled using the relevant TCON and TMOD bits just as with Timer 0. The input signal /INT1 is used with Timer 1; the /INT1 polarity is defined by bit IN1PL in register INT01CF (see Figure 8.13).

**Figure 19.1. T0 Mode 0 Block Diagram**



## 19.1.2. Mode 1: 16-bit Counter/Timer

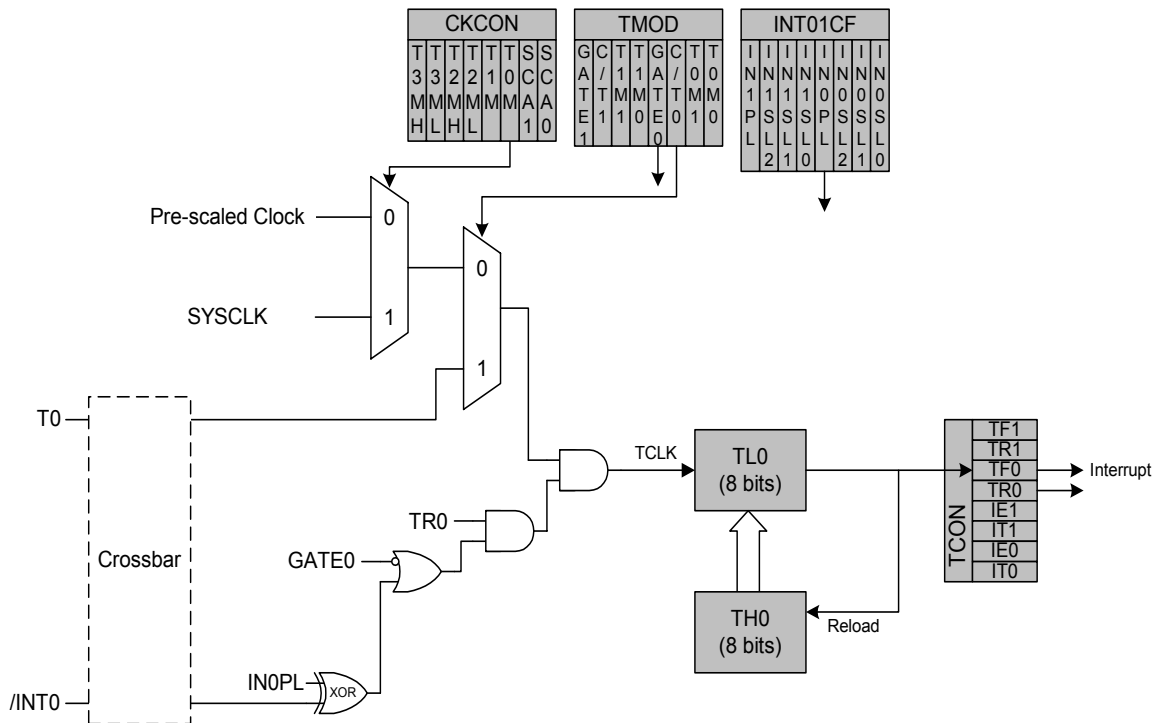
Mode 1 operation is the same as Mode 0, except that the counter/timer registers use all 16 bits. The counter/timers are enabled and configured in Mode 1 in the same manner as for Mode 0.

## 19.1.3. Mode 2: 8-bit Counter/Timer with Auto-Reload

Mode 2 configures Timer 0 and Timer 1 to operate as 8-bit counter/timers with automatic reload of the start value. TL0 holds the count and TH0 holds the reload value. When the counter in TL0 overflows from all ones to 0x00, the timer overflow flag TF0 (TCON.5) is set and the counter in TL0 is reloaded from TH0. If Timer 0 interrupts are enabled, an interrupt will occur when the TF0 flag is set. The reload value in TH0 is not changed. TL0 must be initialized to the desired value before enabling the timer for the first count to be correct. When in Mode 2, Timer 1 operates identically to Timer 0.

Both counter/timers are enabled and configured in Mode 2 in the same manner as Mode 0. Setting the TR0 bit (TCON.4) enables the timer when either GATE0 (TMOD.3) is logic 0 or when the input signal /INT0 is active as defined by bit IN0PL in register INT01CF (see **Section “8.3.2. External Interrupts” on page 59** for details on the external input signals /INT0 and /INT1).

**Figure 19.2. T0 Mode 2 Block Diagram**

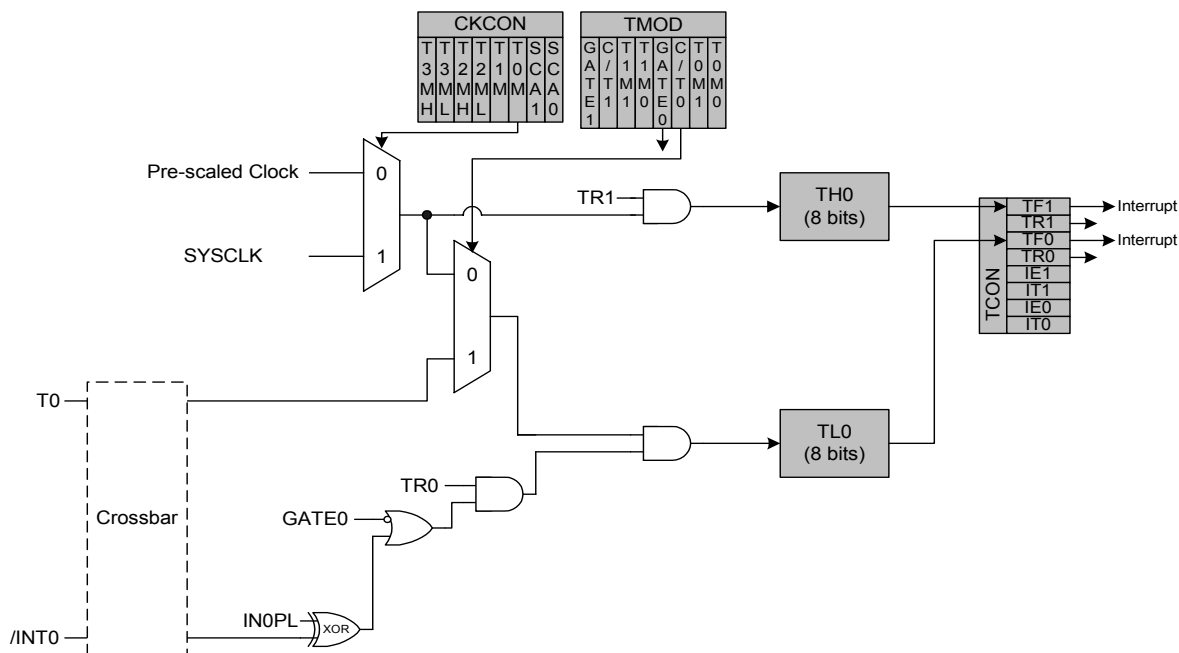


## 19.1.4. Mode 3: Two 8-bit Counter/Timers (Timer 0 Only)

In Mode 3, Timer 0 is configured as two separate 8-bit counter/timers held in TL0 and TH0. The counter/timer in TL0 is controlled using the Timer 0 control/status bits in TCON and TMOD: TR0, C/T0, GATE0 and TF0. TL0 can use either the system clock or an external input signal as its timebase. The TH0 register is restricted to a timer function sourced by the system clock or prescaled clock. TH0 is enabled using the Timer 1 run control bit TR1. TH0 sets the Timer 1 overflow flag TF1 on overflow and thus controls the Timer 1 interrupt.

Timer 1 is inactive in Mode 3. When Timer 0 is operating in Mode 3, Timer 1 can be operated in Modes 0, 1 or 2, but cannot be clocked by external signals nor set the TF1 flag and generate an interrupt. However, the Timer 1 overflow can be used to generate baud rates for the SMBus and/or UART, and/or initiate ADC conversions. While Timer 0 is operating in Mode 3, Timer 1 run control is handled through its mode settings. To run Timer 1 while Timer 0 is in Mode 3, set the Timer 1 Mode as 0, 1, or 2. To disable Timer 1, configure it for Mode 3.

**Figure 19.3. T0 Mode 3 Block Diagram**



**Figure 19.4. TCON: Timer Control Register**

R/W	R/W	R/W	R/W	R/W	R/W	R/W	R/W	Reset Value
TF1	TR1	TF0	TR0	IE1	IT1	IE0	IT0	00000000
Bit7	Bit6	Bit5	Bit4	Bit3	Bit2	Bit1	Bit0	SFR Address: (bit addressable) 0x88

Bit7: TF1: Timer 1 Overflow Flag.  
Set by hardware when Timer 1 overflows. This flag can be cleared by software but is automatically cleared when the CPU vectors to the Timer 1 interrupt service routine.  
0: No Timer 1 overflow detected.  
1: Timer 1 has overflowed.

Bit6: TR1: Timer 1 Run Control.  
0: Timer 1 disabled.  
1: Timer 1 enabled.

Bit5: TF0: Timer 0 Overflow Flag.  
Set by hardware when Timer 0 overflows. This flag can be cleared by software but is automatically cleared when the CPU vectors to the Timer 0 interrupt service routine.  
0: No Timer 0 overflow detected.  
1: Timer 0 has overflowed.

Bit4: TR0: Timer 0 Run Control.  
0: Timer 0 disabled.  
1: Timer 0 enabled.

Bit3: IE1: External Interrupt 1.  
This flag is set by hardware when an edge/level of type defined by IT1 is detected. It can be cleared by software but is automatically cleared when the CPU vectors to the External Interrupt 1 service routine if IT1 = 1. When IT1 = 0, this flag is set to '1' when /INT1 is active as defined by bit IN1PL in register INT01CF (see Figure 8.13).

Bit2: IT1: Interrupt 1 Type Select.  
This bit selects whether the configured /INT1 interrupt will be edge or level sensitive. /INT1 is configured active low or high by the IN1PL bit in the IT01CF register (see Figure 8.13).  
0: /INT1 is level triggered.  
1: /INT1 is edge triggered.

Bit1: IE0: External Interrupt 0.  
This flag is set by hardware when an edge/level of type defined by IT0 is detected. It can be cleared by software but is automatically cleared when the CPU vectors to the External Interrupt 0 service routine if IT0 = 1. When IT0 = 0, this flag is set to '1' when /INT0 is active as defined by bit IN0PL in register INT01CF (see Figure 8.13).

Bit0: IT0: Interrupt 0 Type Select.  
This bit selects whether the configured /INT0 interrupt will be edge or level sensitive. /INT0 is configured active low or high by the IN0PL bit in register IT01CF (see Figure 8.13).  
0: /INT0 is level triggered.  
1: /INT0 is edge triggered.

**Figure 19.5. TMOD: Timer Mode Register**

<b>R/W</b>	<b>R/W</b>	<b>R/W</b>	<b>R/W</b>	<b>R/W</b>	<b>R/W</b>	<b>R/W</b>	<b>R/W</b>	<b>Reset Value</b>
<b>GATE1</b>	<b>C/T1</b>	<b>T1M1</b>	<b>T1M0</b>	<b>GATE0</b>	<b>C/T0</b>	<b>T0M1</b>	<b>T0M0</b>	<b>00000000</b>
Bit7	Bit6	Bit5	Bit4	Bit3	Bit2	Bit1	Bit0	SFR Address: <b>0x89</b>

Bit7: GATE1: Timer 1 Gate Control.  
 0: Timer 1 enabled when TR1 = 1 irrespective of /INT1 logic level.  
 1: Timer 1 enabled only when TR1 = 1 AND /INT1 is active as defined by bit IN1PL in register INT01CF (see Figure 8.13).

Bit6: C/T1: Counter/Timer 1 Select.  
 0: Timer Function: Timer 1 incremented by clock defined by T1M bit (CKCON.4).  
 1: Counter Function: Timer 1 incremented by high-to-low transitions on external input pin (T1).

Bits5-4: T1M1-T1M0: Timer 1 Mode Select.  
 These bits select the Timer 1 operation mode.

<b>T1M1</b>	<b>T1M0</b>	<b>Mode</b>
0	0	Mode 0: 13-bit counter/timer
0	1	Mode 1: 16-bit counter/timer
1	0	Mode 2: 8-bit counter/timer with auto-reload
1	1	Mode 3: Timer 1 inactive

Bit3: GATE0: Timer 0 Gate Control.  
 0: Timer 0 enabled when TR0 = 1 irrespective of /INT0 logic level.  
 1: Timer 0 enabled only when TR0 = 1 AND /INT0 is active as defined by bit IN0PL in register INT01CF (see Figure 8.13).

Bit2: C/T0: Counter/Timer Select.  
 0: Timer Function: Timer 0 incremented by clock defined by T0M bit (CKCON.3).  
 1: Counter Function: Timer 0 incremented by high-to-low transitions on external input pin (T0).

Bits1-0: T0M1-T0M0: Timer 0 Mode Select.  
 These bits select the Timer 0 operation mode.

<b>T0M1</b>	<b>T0M0</b>	<b>Mode</b>
0	0	Mode 0: 13-bit counter/timer
0	1	Mode 1: 16-bit counter/timer
1	0	Mode 2: 8-bit counter/timer with auto-reload
1	1	Mode 3: Two 8-bit counter/timers

**Figure 19.6. CKCON: Clock Control Register**

R/W	R/W	R/W	R/W	R/W	R/W	R/W	R/W	Reset Value
T3MH	T3ML	T2MH	T2ML	T1M	T0M	SCA1	SCA0	00000000
Bit7	Bit6	Bit5	Bit4	Bit3	Bit2	Bit1	Bit0	SFR Address: 0x8E

Bit7:     **T3MH: Timer 3 High Byte Clock Select.**  
This bit selects the clock supplied to the Timer 3 high byte if Timer 3 is configured in split 8-bit timer mode. T3MH is ignored if Timer 3 is in any other mode.  
0: Timer 3 high byte uses the clock defined by the T3XCLK bit in TMR3CN.  
1: Timer 3 high byte uses the system clock.

Bit6:     **T3ML: Timer 3 Low Byte Clock Select.**  
This bit selects the clock supplied to Timer 3. If Timer 3 is configured in split 8-bit timer mode, this bit selects the clock supplied to the lower 8-bit timer.  
0: Timer 3 low byte uses the clock defined by the T3XCLK bit in TMR3CN.  
1: Timer 3 low byte uses the system clock.

Bit5:     **T2MH: Timer 2 High Byte Clock Select.**  
This bit selects the clock supplied to the Timer 2 high byte if Timer 2 is configured in split 8-bit timer mode. T2MH is ignored if Timer 2 is in any other mode.  
0: Timer 2 high byte uses the clock defined by the T2XCLK bit in TMR2CN.  
1: Timer 2 high byte uses the system clock.

Bit4:     **T2ML: Timer 2 Low Byte Clock Select.**  
This bit selects the clock supplied to Timer 2. If Timer 2 is configured in split 8-bit timer mode, this bit selects the clock supplied to the lower 8-bit timer.  
0: Timer 2 low byte uses the clock defined by the T2XCLK bit in TMR2CN.  
1: Timer 2 low byte uses the system clock.

Bit3:     **T1M: Timer 1 Clock Select.**  
This select the clock source supplied to Timer 1. T1M is ignored when C/T1 is set to logic 1.  
0: Timer 1 uses the clock defined by the prescale bits, SCA1-SCA0.  
1: Timer 1 uses the system clock.

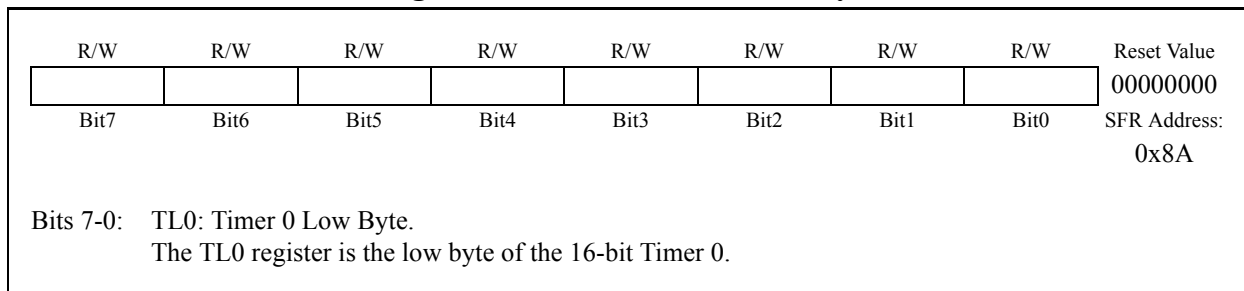
Bit2:     **T0M: Timer 0 Clock Select.**  
This bit selects the clock source supplied to Timer 0. T0M is ignored when C/T0 is set to logic 1.  
0: Counter/Timer 0 uses the clock defined by the prescale bits, SCA1-SCA0.  
1: Counter/Timer 0 uses the system clock.

Bits1-0:   **SCA1-SCA0: Timer 0/1 Prescale Bits.**  
These bits control the division of the clock supplied to Timer 0 and/or Timer 1 if configured to use prescaled clock inputs.

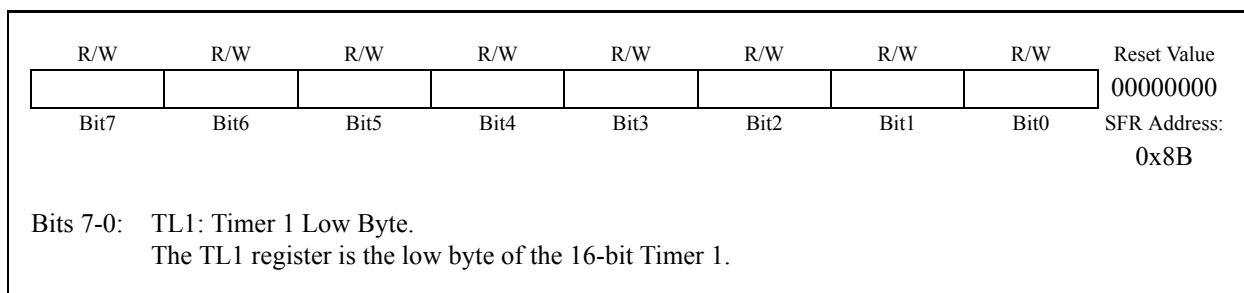
SCA1	SCA0	Prescaled Clock
0	0	System clock divided by 12
0	1	System clock divided by 4
1	0	System clock divided by 48
1	1	External clock divided by 8

Note: External clock divided by 8 is synchronized with the system clock.

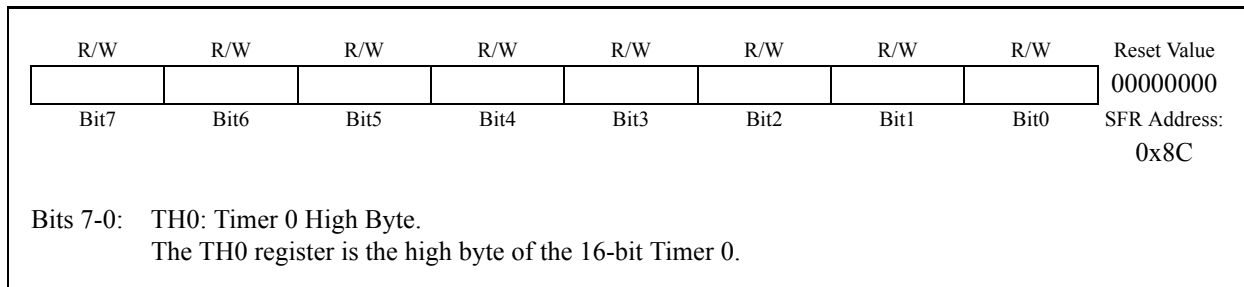
**Figure 19.7. TL0: Timer 0 Low Byte**



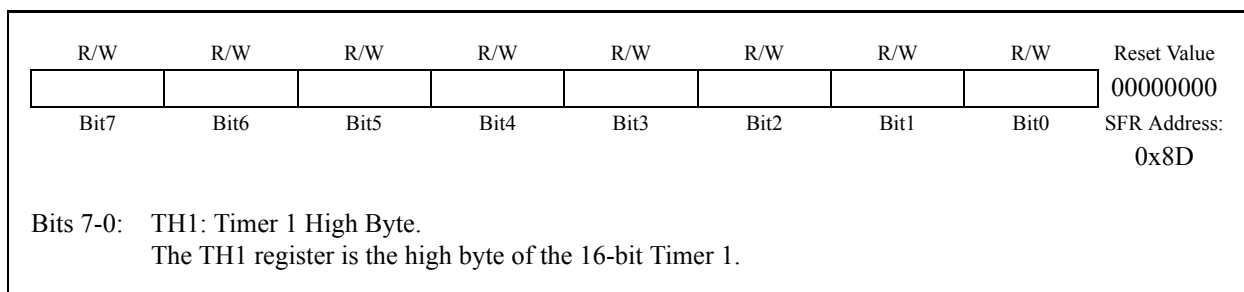
**Figure 19.8. TL1: Timer 1 Low Byte**



**Figure 19.9. TH0: Timer 0 High Byte**



**Figure 19.10. TH1: Timer 1 High Byte**





## 19.2. Timer 2

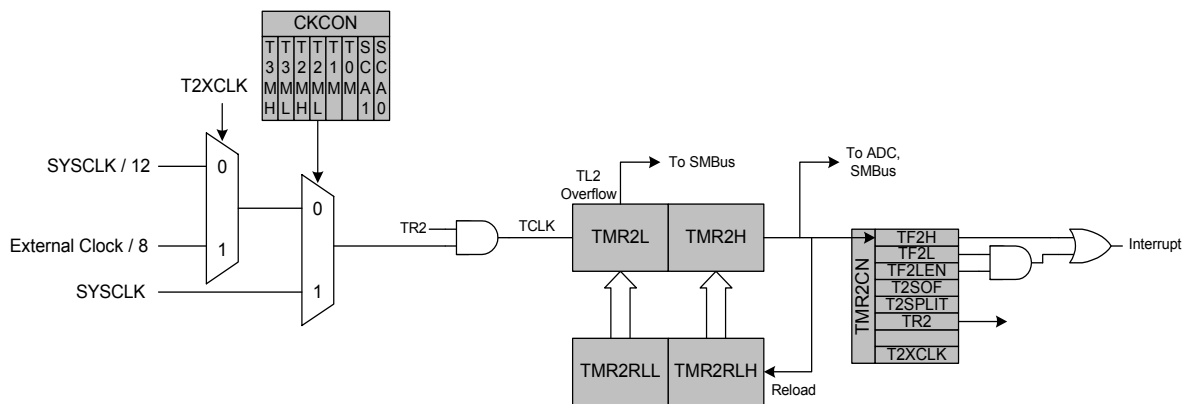
Timer 2 is a 16-bit timer formed by two 8-bit SFRs: TMR2L (low byte) and TMR2H (high byte). Timer 2 may operate in 16-bit auto-reload mode, (split) 8-bit auto-reload mode, or USB Start-of-Frame (SOF) capture mode. The Timer 2 operation mode is defined by the T2SPLIT (TMR2CN.3) and T2SOF (TMR2CN.4) bits.

Timer 2 may be clocked by the system clock, the system clock divided by 12, or the external oscillator source divided by 8. The external clock mode is ideal for real-time clock (RTC) functionality, where the internal oscillator drives the system clock while Timer 2 (and/or the PCA) is clocked by an external precision oscillator. Note that the external oscillator source divided by 8 is synchronized with the system clock.

### 19.2.1. 16-bit Timer with Auto-Reload

When T2SPLIT = '0' and T2SOF = '0', Timer 2 operates as a 16-bit timer with auto-reload. Timer 2 can be clocked by SYSCLK, SYSCLK divided by 12, or the external oscillator clock source divided by 8. As the 16-bit timer register increments and overflows from 0xFFFF to 0x0000, the 16-bit value in the Timer 2 reload registers (TMR2RLH and TMR2RLL) is loaded into the Timer 2 register as shown in Figure 19.11, and the Timer 2 High Byte Overflow Flag (TMR2CN.7) is set. If Timer 2 interrupts are enabled (if IE.5 is set), an interrupt will be generated on each Timer 2 overflow. Additionally, if Timer 2 interrupts are enabled and the TF2LEN bit is set (TMR2CN.5), an interrupt will be generated each time the lower 8 bits (TMR2L) overflow from 0xFF to 0x00.

**Figure 19.11. Timer 2 16-Bit Mode Block Diagram**



## 19.2.2. 8-bit Timers with Auto-Reload

When T2SPLIT = '1' and T2SOF = '0', Timer 2 operates as two 8-bit timers (TMR2H and TMR2L). Both 8-bit timers operate in auto-reload mode as shown in Figure 19.12. TMR2RLL holds the reload value for TMR2L; TMR2RLH holds the reload value for TMR2H. The TR2 bit in TMR2CN handles the run control for TMR2H. TMR2L is always running when configured for 8-bit Mode.

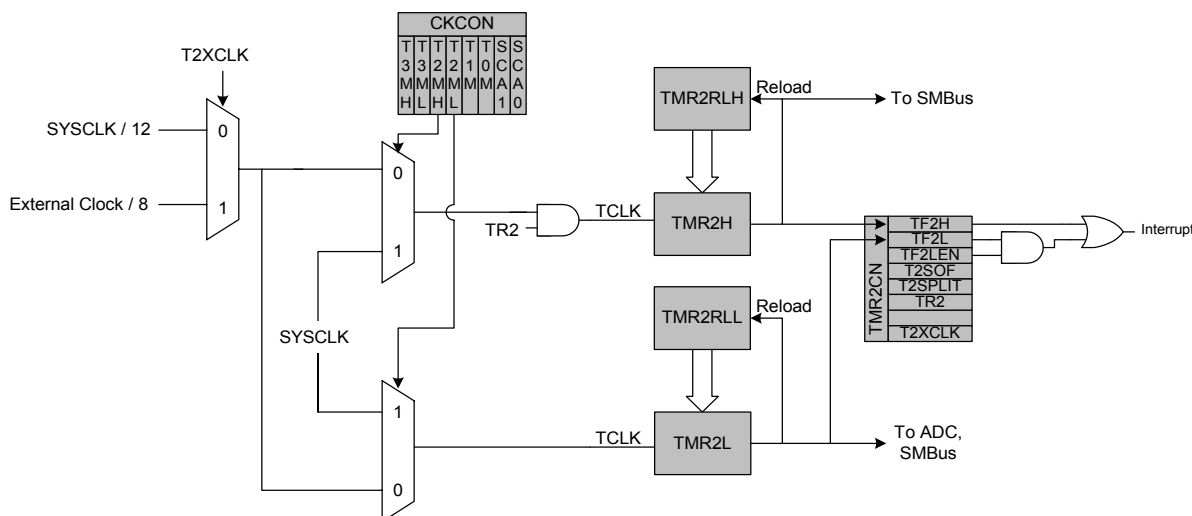
Each 8-bit timer may be configured to use SYSCLK, SYSCLK divided by 12, or the external oscillator clock source divided by 8. The Timer 2 Clock Select bits (T2MH and T2ML in CKCON) select either SYSCLK or the clock defined by the Timer 2 External Clock Select bit (T2XCLK in TMR2CN), as follows:

T2MH	T2XCLK	TMR2H Clock Source
0	0	SYSCLK / 12
0	1	External Clock / 8
1	X	SYSCLK

T2ML	T2XCLK	TMR2L Clock Source
0	0	SYSCLK / 12
0	1	External Clock / 8
1	X	SYSCLK

The TF2H bit is set when TMR2H overflows from 0xFF to 0x00; the TF2L bit is set when TMR2L overflows from 0xFF to 0x00. When Timer 2 interrupts are enabled (IE.5), an interrupt is generated each time TMR2H overflows. If Timer 2 interrupts are enabled and TF2LEN (TMR2CN.5) is set, an interrupt is generated each time either TMR2L or TMR2H overflows. When TF2LEN is enabled, software must check the TF2H and TF2L flags to determine the source of the Timer 2 interrupt. The TF2H and TF2L interrupt flags are not cleared by hardware and must be manually cleared by software.

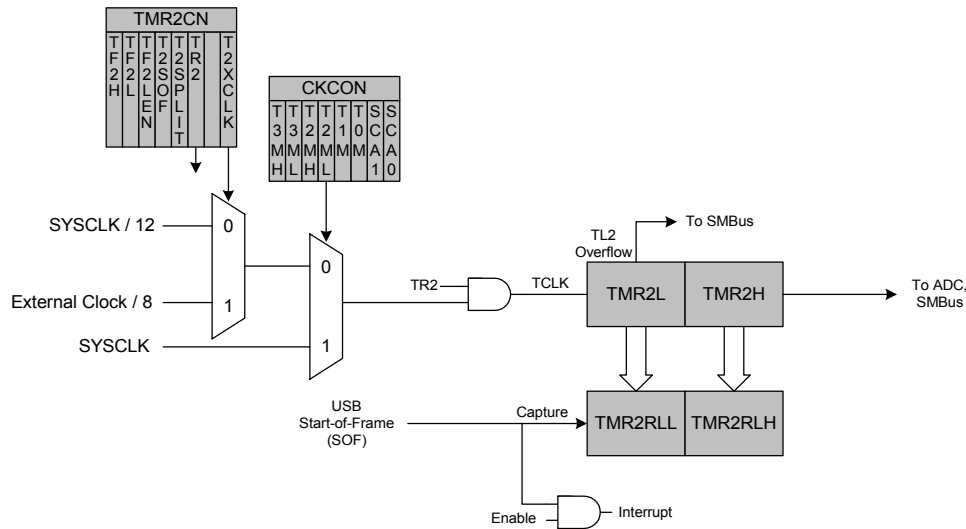
**Figure 19.12. Timer 2 8-Bit Mode Block Diagram**



## 19.2.3. USB Start-of-Frame Capture

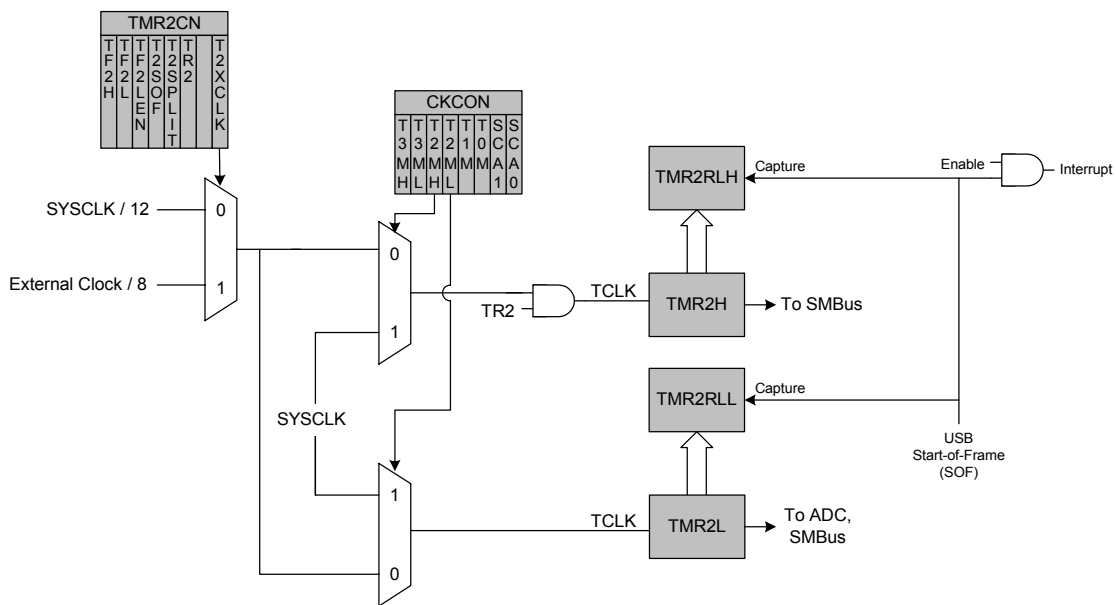
When T2SOF = '1', Timer 2 operates in USB Start-of-Frame (SOF) capture mode. When T2SPLIT = '0', Timer 2 counts up and overflows from 0xFFFF to 0x0000. Each time a USB SOF is received, the contents of the Timer 2 registers (TMR2H:TMR2L) are latched into the Timer 2 Reload registers (TMR2RLH:TMR2RLL). A Timer 2 interrupt is generated if enabled. This mode can be used to calibrate the system clock or external oscillator against the known USB host SOF clock.

**Figure 19.13. Timer 2 SOF Capture Mode (T2SPLIT = '0')**



When T2SPLIT = '1', the Timer 2 registers (TMR2H and TMR2L) act as two 8-bit counters. Each counter counts up independently and overflows from 0xFF to 0x00. Each time a USB SOF is received, the contents of the Timer 2 registers are latched into the Timer 2 Reload registers (TMR2RLH and TMR2RLL). A Timer 2 interrupt is generated if enabled.

**Figure 19.14. Timer 2 SOF Capture Mode (T2SPLIT = '1')**



**Figure 19.15. TMR2CN: Timer 2 Control Register**

R/W	R/W	R/W	R/W	R/W	R/W	R/W	R/W	Reset Value
TF2H	TF2L	TF2LEN	T2SOF	T2SPLIT	TR2	-	T2XCLK	00000000
Bit7	Bit6	Bit5	Bit4	Bit3	Bit2	Bit1	Bit0	SFR Address: 0xC8 (bit addressable)

Bit7: TF2H: Timer 2 High Byte Overflow Flag.  
Set by hardware when the Timer 2 high byte overflows from 0xFF to 0x00. In 16 bit mode, this will occur when Timer 2 overflows from 0xFFFF to 0x0000. When the Timer 2 interrupt is enabled, setting this bit causes the CPU to vector to the Timer 2 interrupt service routine. TF2H is not automatically cleared by hardware and must be cleared by software.

Bit6: TF2L: Timer 2 Low Byte Overflow Flag.  
Set by hardware when the Timer 2 low byte overflows from 0xFF to 0x00. When this bit is set, an interrupt will be generated if TF2LEN is set and Timer 2 interrupts are enabled. TF2L will set when the low byte overflows regardless of the Timer 2 mode. This bit is not automatically cleared by hardware.

Bit5: TF2LEN: Timer 2 Low Byte Interrupt Enable.  
This bit enables/disables Timer 2 Low Byte interrupts. If TF2LEN is set and Timer 2 interrupts are enabled, an interrupt will be generated when the low byte of Timer 2 overflows.  
0: Timer 2 Low Byte interrupts disabled.  
1: Timer 2 Low Byte interrupts enabled.

Bit4: T2SOF: Timer 2 Start-Of-Frame Capture Enable  
0: SOF Capture disabled.  
1: SOF Capture enabled. Each time a USB SOF is received, the contents of the Timer 2 registers (TMR2H and TMR2L) are latched into the Timer 2 reload registers (TMR2RLH and TMR2RLH), and a Timer 2 interrupt is generated (if enabled).

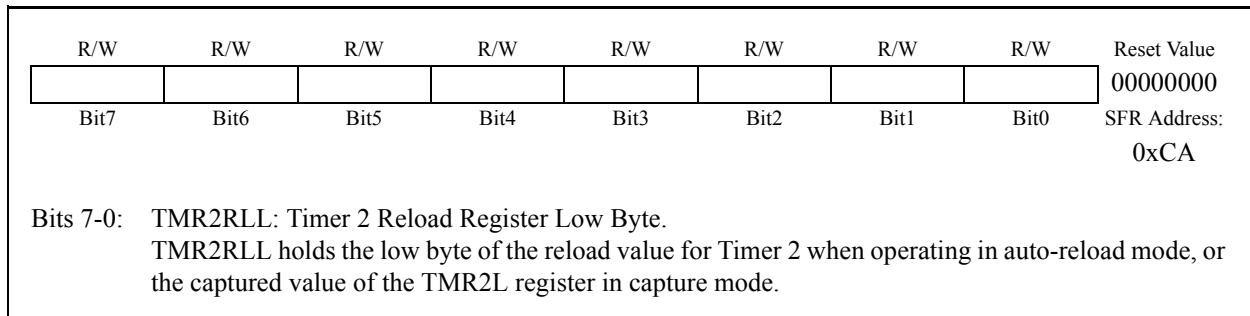
Bit3: T2SPLIT: Timer 2 Split Mode Enable.  
When this bit is set, Timer 2 operates as two 8-bit timers with auto-reload.  
0: Timer 2 operates in 16-bit auto-reload mode.  
1: Timer 2 operates as two 8-bit auto-reload timers.

Bit2: TR2: Timer 2 Run Control.  
This bit enables/disables Timer 2. In 8-bit mode, this bit enables/disables TMR2H only; TMR2L is always enabled in this mode.  
0: Timer 2 disabled.  
1: Timer 2 enabled.

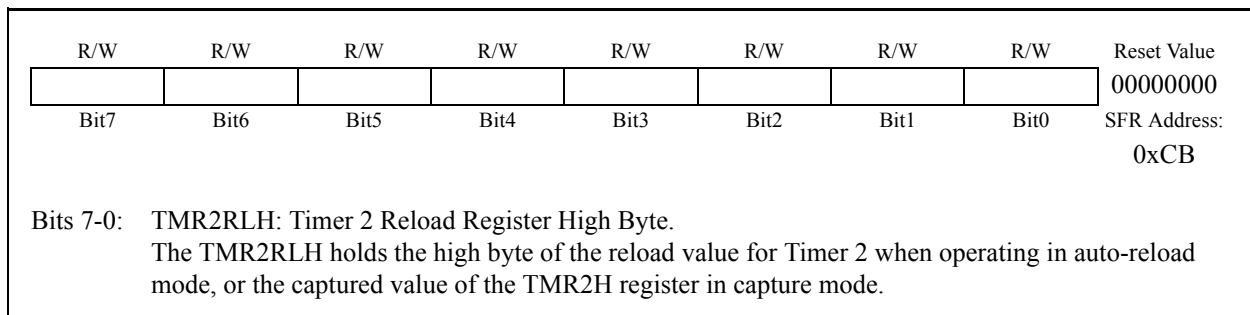
Bit1: UNUSED. Read = 0b. Write = don't care.

Bit0: T2XCLK: Timer 2 External Clock Select.  
This bit selects the external clock source for Timer 2. If Timer 2 is in 8-bit mode, this bit selects the external oscillator clock source for both timer bytes. However, the Timer 2 Clock Select bits (T2MH and T2ML in register CKCON) may still be used to select between the external clock and the system clock for either timer.  
0: Timer 2 external clock selection is the system clock divided by 12.  
1: Timer 2 external clock selection is the external clock divided by 8. Note that the external oscillator source divided by 8 is synchronized with the system clock.

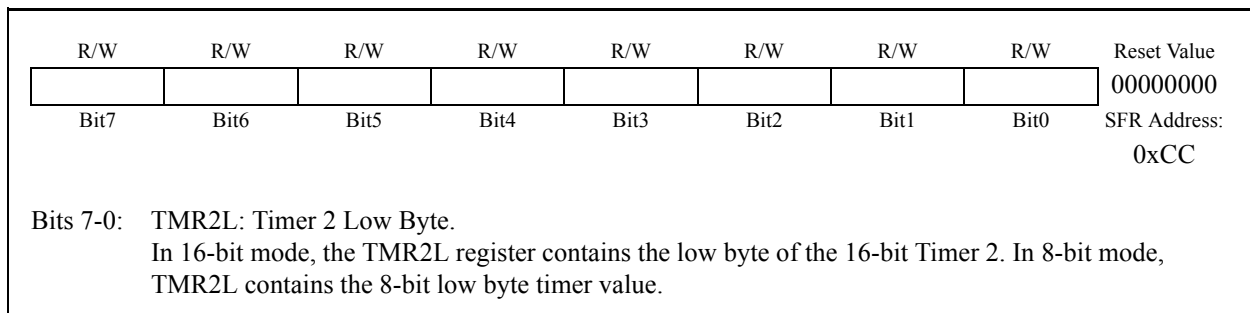
**Figure 19.16. TMR2RLL: Timer 2 Reload Register Low Byte**



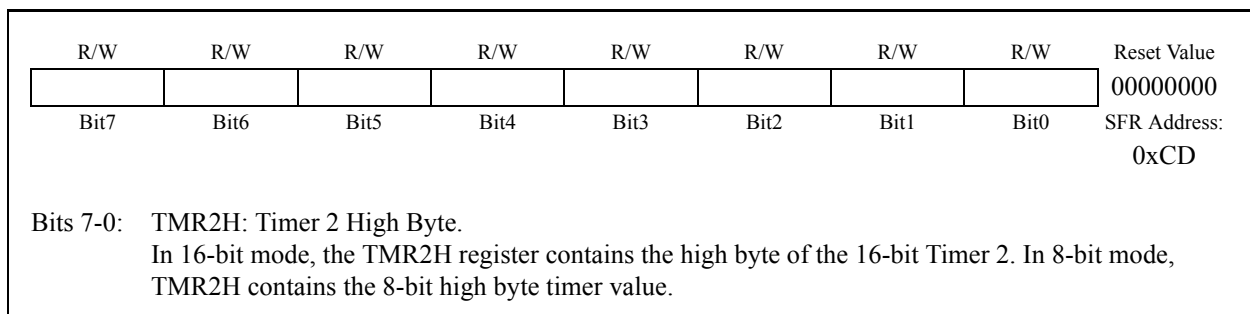
**Figure 19.17. TMR2RLH: Timer 2 Reload Register High Byte**



**Figure 19.18. TMR2L: Timer 2 Low Byte**



**Figure 19.19. TMR2H Timer 2 High Byte**



## 19.3. Timer 3

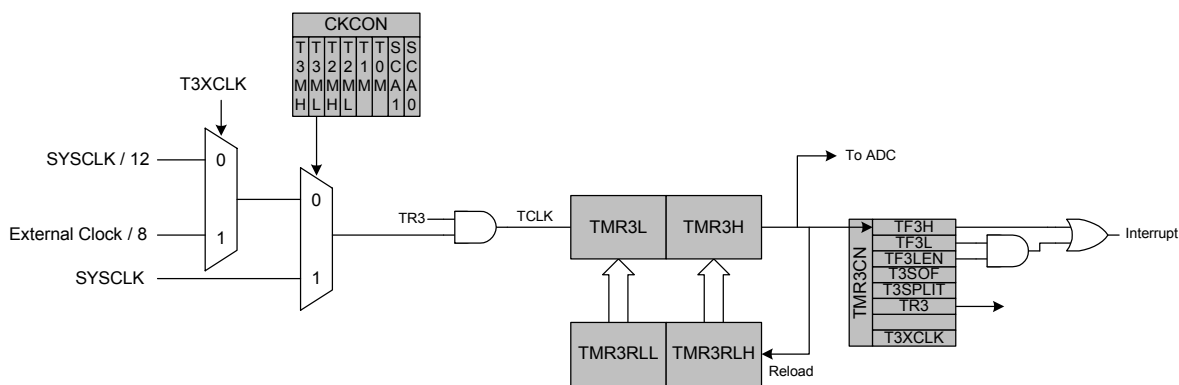
Timer 3 is a 16-bit timer formed by two 8-bit SFRs: TMR3L (low byte) and TMR3H (high byte). Timer 3 may operate in 16-bit auto-reload mode, (split) 8-bit auto-reload mode, or USB Start-of-Frame (SOF) capture mode. The Timer 3 operation mode is defined by the T3SPLIT (TMR3CN.3) and T3SOF (TMR2CN.4) bits.

Timer 3 may be clocked by the system clock, the system clock divided by 12, or the external oscillator source divided by 8. The external clock mode is ideal for real-time clock (RTC) functionality, where the internal oscillator drives the system clock while Timer 3 (and/or the PCA) is clocked by an external precision oscillator. Note that the external oscillator source divided by 8 is synchronized with the system clock.

### 19.3.1. 16-bit Timer with Auto-Reload

When T3SPLIT (TMR3CN.3) is zero, Timer 3 operates as a 16-bit timer with auto-reload. Timer 3 can be clocked by SYSCLK, SYSCLK divided by 12, or the external oscillator clock source divided by 8. As the 16-bit timer register increments and overflows from 0xFFFF to 0x0000, the 16-bit value in the Timer 3 reload registers (TMR3RLH and TMR3RLL) is loaded into the Timer 3 register as shown in Figure 19.11, and the Timer 3 High Byte Overflow Flag (TMR3CN.7) is set. If Timer 3 interrupts are enabled (if IE.5 is set), an interrupt will be generated on each Timer 3 overflow. Additionally, if Timer 3 interrupts are enabled and the TF3LEN bit is set (TMR3CN.5), an interrupt will be generated each time the lower 8 bits (TMR3L) overflow from 0xFF to 0x00.

**Figure 19.20. Timer 3 16-Bit Mode Block Diagram**



## 19.3.2. 8-bit Timers with Auto-Reload

When T3SPLIT is set, Timer 3 operates as two 8-bit timers (TMR3H and TMR3L). Both 8-bit timers operate in auto-reload mode as shown in Figure 19.12. TMR3RLL holds the reload value for TMR3L; TMR3RLH holds the reload value for TMR3H. The TR3 bit in TMR3CN handles the run control for TMR3H. TMR3L is always running when configured for 8-bit Mode.

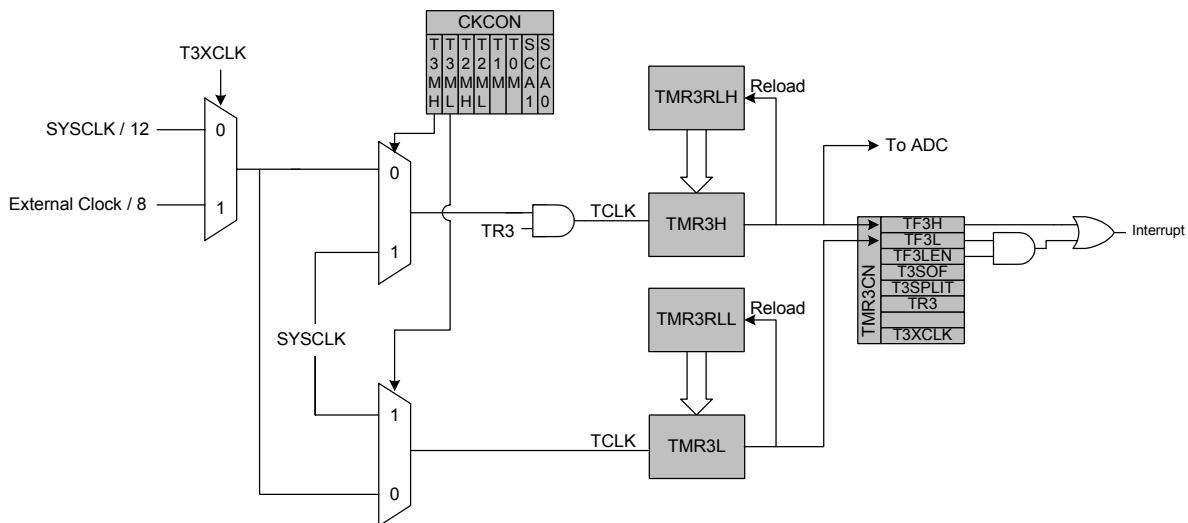
Each 8-bit timer may be configured to use SYSCLK, SYSCLK divided by 12, or the external oscillator clock source divided by 8. The Timer 3 Clock Select bits (T3MH and T3ML in CKCON) select either SYSCLK or the clock defined by the Timer 3 External Clock Select bit (T3XCLK in TMR3CN), as follows:

T3MH	T3XCLK	TMR3H Clock Source
0	0	SYSCLK / 12
0	1	External Clock / 8
1	X	SYSCLK

T3ML	T3XCLK	TMR3L Clock Source
0	0	SYSCLK / 12
0	1	External Clock / 8
1	X	SYSCLK

The TF3H bit is set when TMR3H overflows from 0xFF to 0x00; the TF3L bit is set when TMR3L overflows from 0xFF to 0x00. When Timer 3 interrupts are enabled (IE.5), an interrupt is generated each time TMR3H overflows. If Timer 3 interrupts are enabled and TF3LEN (TMR3CN.5) is set, an interrupt is generated each time either TMR3L or TMR3H overflows. When TF3LEN is enabled, software must check the TF3H and TF3L flags to determine the source of the Timer 3 interrupt. The TF3H and TF3L interrupt flags are not cleared by hardware and must be manually cleared by software.

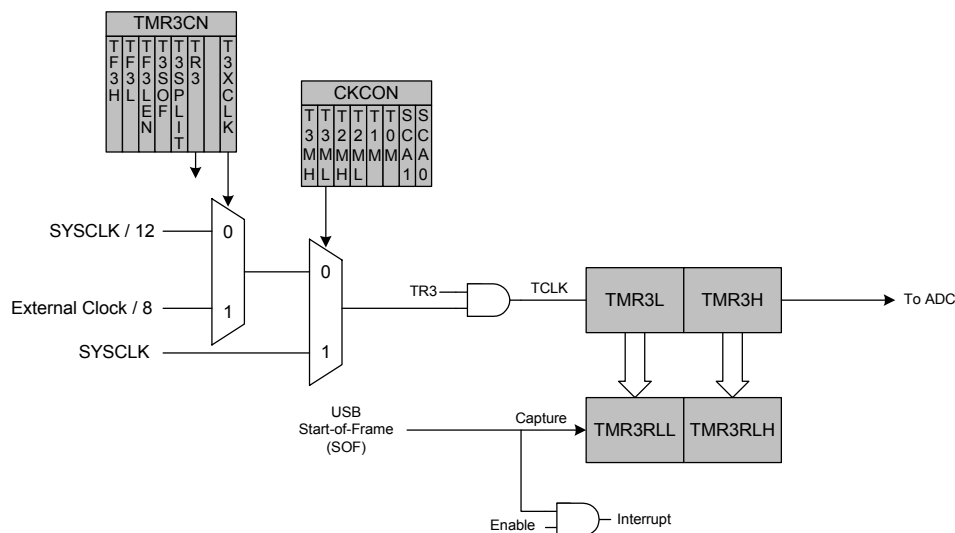
**Figure 19.21. Timer 3 8-Bit Mode Block Diagram**



## 19.3.3. USB Start-of-Frame Capture

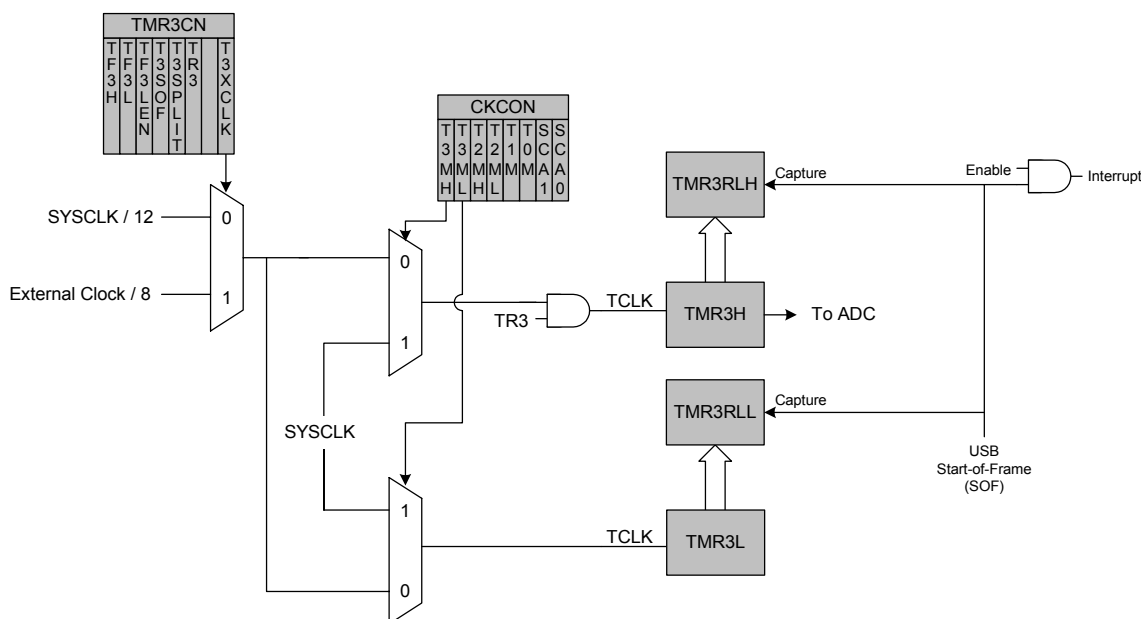
When T3SOF = '1', Timer 3 operates in USB Start-of-Frame (SOF) capture mode. When T3SPLIT = '0', Timer 3 counts up and overflows from 0xFFFF to 0x0000. Each time a USB SOF is received, the contents of the Timer 3 registers (TMR3H:TMR3L) are latched into the Timer 3 Reload registers (TMR3RLH:TMR3RLL). A Timer 3 interrupt is generated if enabled. This mode can be used to calibrate the system clock or external oscillator against the known USB host SOF clock.

**Figure 19.22. Timer 3**



When T3SPLIT = '1', the Timer 3 registers (TMR3H and TMR3L) act as two 8-bit counters. Each counter counts up independently and overflows from 0xFF to 0x00. Each time a USB SOF is received, the contents of the Timer 3 registers are latched into the Timer 3 Reload registers (TMR3RLH and TMR3RLL). A Timer 3 interrupt is generated if enabled.

**Figure 19.23. Timer 3 SOF Capture Mode (T3SPLIT = '1')**





**Figure 19.24. TMR3CN: Timer 3 Control Register**

R/W	R/W	R/W	R/W	R/W	R/W	R/W	R/W	Reset Value
TF3H	TF3L	TF3LEN	T3SOF	T3SPLIT	TR3	-	T3XCLK	00000000
Bit7	Bit6	Bit5	Bit4	Bit3	Bit2	Bit1	Bit0	SFR Address: 0x91

Bit7: TF3H: Timer 3 High Byte Overflow Flag.  
Set by hardware when the Timer 3 high byte overflows from 0xFF to 0x00. In 16 bit mode, this will occur when Timer 3 overflows from 0xFFFF to 0x0000. When the Timer 3 interrupt is enabled, setting this bit causes the CPU to vector to the Timer 3 interrupt service routine. TF3H is not automatically cleared by hardware and must be cleared by software.

Bit6: TF3L: Timer 3 Low Byte Overflow Flag.  
Set by hardware when the Timer 3 low byte overflows from 0xFF to 0x00. When this bit is set, an interrupt will be generated if TF3LEN is set and Timer 3 interrupts are enabled. TF3L will set when the low byte overflows regardless of the Timer 3 mode. This bit is not automatically cleared by hardware.

Bit5: TF3LEN: Timer 3 Low Byte Interrupt Enable.  
This bit enables/disables Timer 3 Low Byte interrupts. If TF3LEN is set and Timer 3 interrupts are enabled, an interrupt will be generated when the low byte of Timer 3 overflows. This bit should be cleared when operating Timer 3 in 16-bit mode.  
0: Timer 3 Low Byte interrupts disabled.  
1: Timer 3 Low Byte interrupts enabled.

Bit4: T3SOF: Timer 3 Start-Of-Frame Capture Enable  
0: SOF Capture disabled.  
1: SOF Capture enabled. Each time a USB SOF is received, the contents of the Timer 3 registers (TMR3H and TMR3L) are latched into the Timer3 reload registers (TMR3RLH and TMR3RLH), and a Timer 3 interrupt is generated (if enabled).

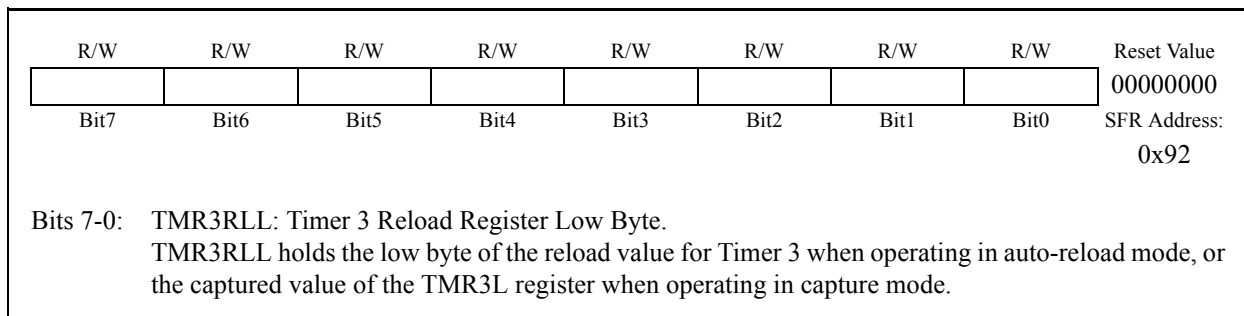
Bit3: T3SPLIT: Timer 3 Split Mode Enable.  
When this bit is set, Timer 3 operates as two 8-bit timers with auto-reload.  
0: Timer 3 operates in 16-bit auto-reload mode.  
1: Timer 3 operates as two 8-bit auto-reload timers.

Bit2: TR3: Timer 3 Run Control.  
This bit enables/disables Timer 3. In 8-bit mode, this bit enables/disables TMR3H only; TMR3L is always enabled in this mode.  
0: Timer 3 disabled.  
1: Timer 3 enabled.

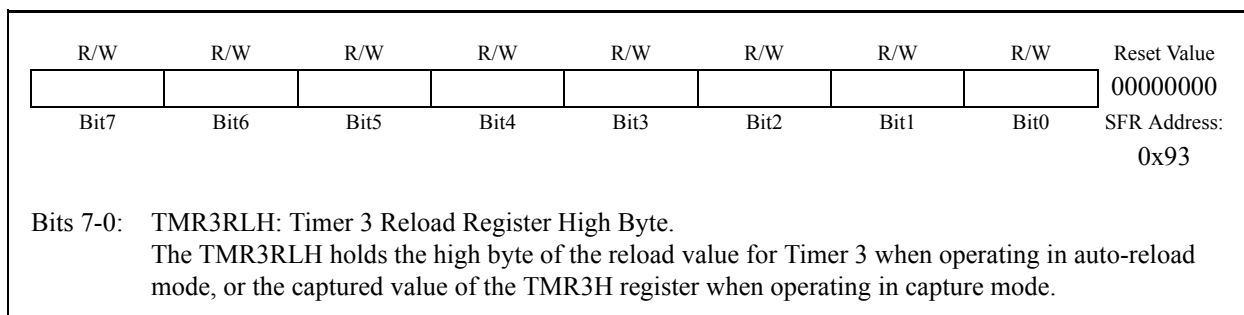
Bit1: UNUSED. Read = 0b. Write = don't care.

Bit0: T3XCLK: Timer 3 External Clock Select.  
This bit selects the external clock source for Timer 3. If Timer 3 is in 8-bit mode, this bit selects the external oscillator clock source for both timer bytes. However, the Timer 3 Clock Select bits (T3MH and T3ML in register CKCON) may still be used to select between the external clock and the system clock for either timer.  
0: Timer 3 external clock selection is the system clock divided by 12.  
1: Timer 3 external clock selection is the external clock divided by 8. Note that the external oscillator source divided by 8 is synchronized with the system clock.

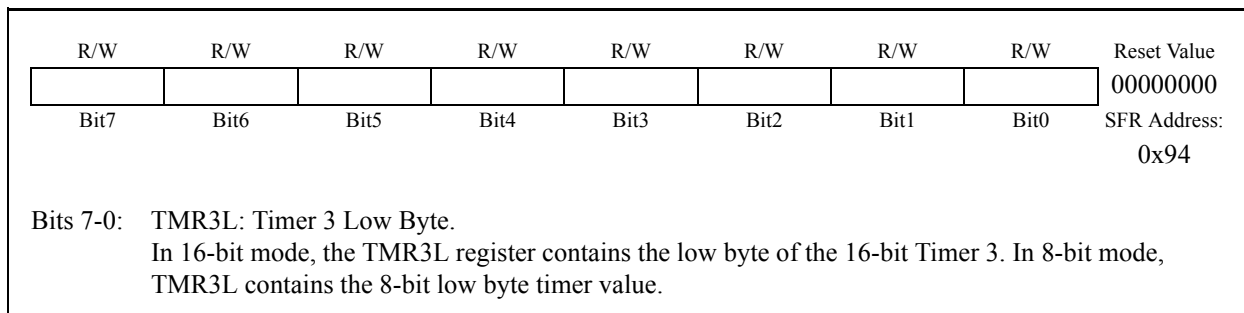
**Figure 19.25. TMR3RLL: Timer 3 Reload Register Low Byte**



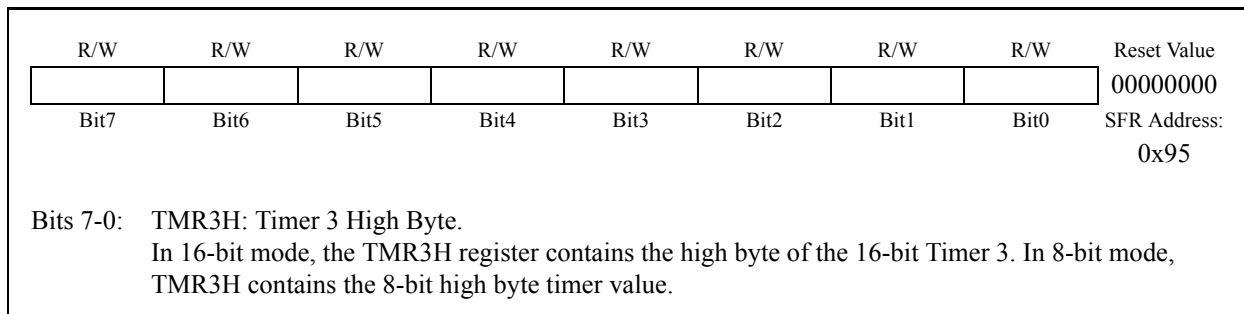
**Figure 19.26. TMR3RLH: Timer 3 Reload Register High Byte**



**Figure 19.27. TMR3L: Timer 3 Low Byte**



**Figure 19.28. TMR3H Timer 3 High Byte**

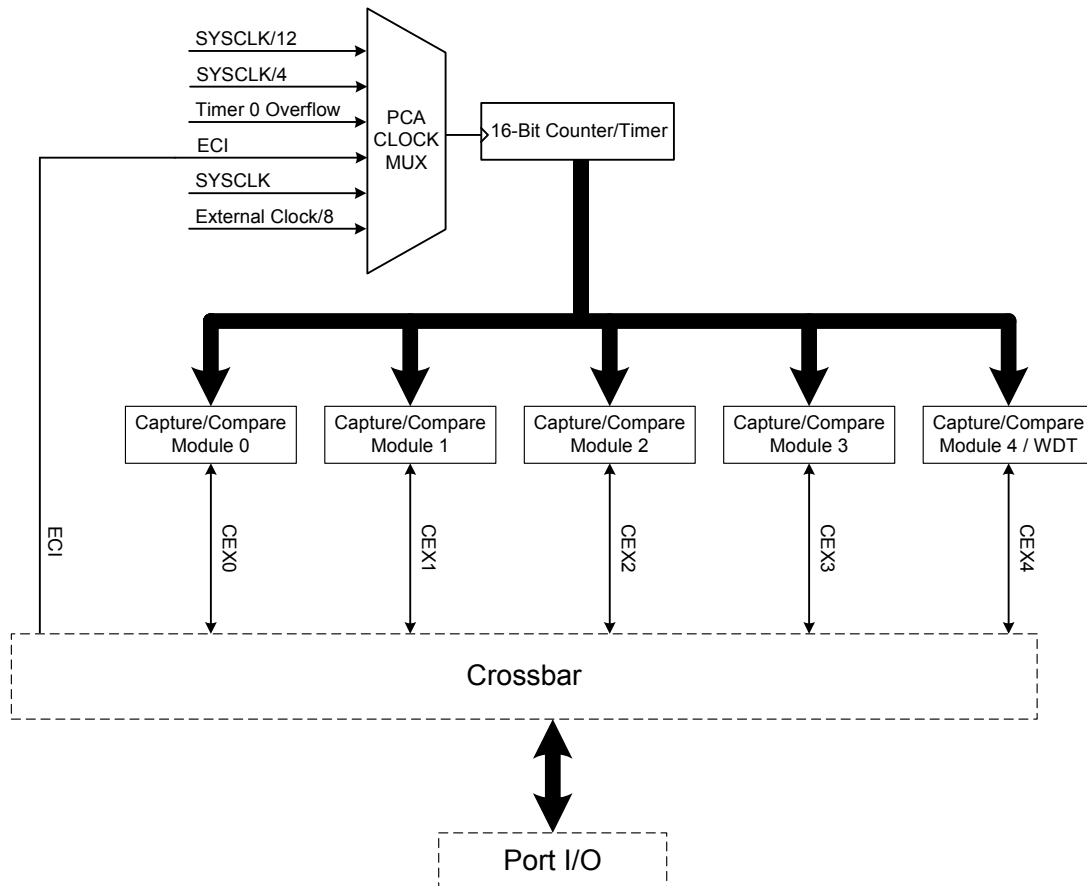


## 20. PROGRAMMABLE COUNTER ARRAY (PCA0)

The Programmable Counter Array (PCA0) provides enhanced timer functionality while requiring less CPU intervention than the standard 8051 counter/timers. The PCA consists of a dedicated 16-bit counter/timer and five 16-bit capture/compare modules. Each capture/compare module has its own associated I/O line (CEX<sub>n</sub>) which is routed through the Crossbar to Port I/O when enabled (See [Section “14.1. Priority Crossbar Decoder” on page 129](#) for details on configuring the Crossbar). The counter/timer is driven by a programmable timebase that can select between six sources: system clock, system clock divided by four, system clock divided by twelve, the external oscillator clock source divided by 8, Timer 0 overflow, or an external clock signal on the ECI input pin. Each capture/compare module may be configured to operate independently in one of six modes: Edge-Triggered Capture, Software Timer, High-Speed Output, Frequency Output, 8-Bit PWM, or 16-Bit PWM (each mode is described in [Section “20.2. Capture/Compare Modules” on page 237](#)). The external oscillator clock option is ideal for real-time clock (RTC) functionality, allowing the PCA to be clocked by a precision external oscillator while the internal oscillator drives the system clock. The PCA is configured and controlled through the system controller's Special Function Registers. The PCA block diagram is shown in Figure 20.1

**Important Note:** The PCA Module 4 may be used as a watchdog timer (WDT), and is enabled in this mode following a system reset. Access to certain PCA registers is restricted while WDT mode is enabled. See [Section 20.3](#) for details.

Figure 20.1. PCA Block Diagram



## 20.1. PCA Counter/Timer

The 16-bit PCA counter/timer consists of two 8-bit SFRs: PCA0L and PCA0H. PCA0H is the high byte (MSB) of the 16-bit counter/timer and PCA0L is the low byte (LSB). Reading PCA0L automatically latches the value of PCA0H into a “snapshot” register; the following PCA0H read accesses this “snapshot” register. **Reading the PCA0L Register first guarantees an accurate reading of the entire 16-bit PCA0 counter.** Reading PCA0H or PCA0L does not disturb the counter operation. The CPS2-CPS0 bits in the PCA0MD register select the timebase for the counter/timer as shown in Table 20.1.

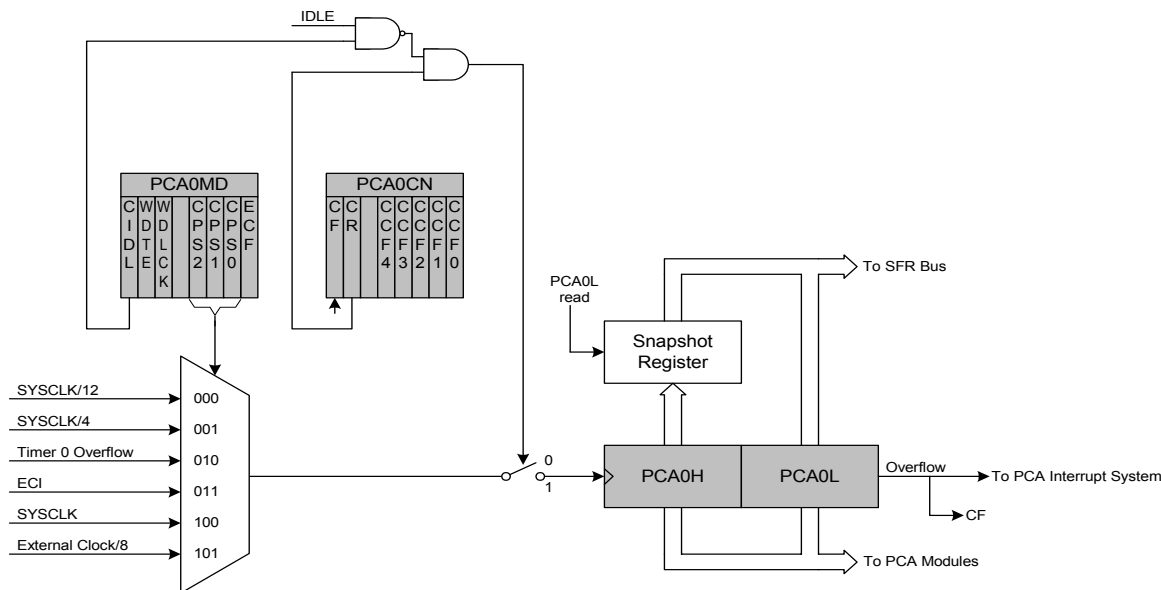
When the counter/timer overflows from 0xFFFF to 0x0000, the Counter Overflow Flag (CF) in PCA0MD is set to logic 1 and an interrupt request is generated if CF interrupts are enabled. Setting the ECF bit in PCA0MD to logic 1 enables the CF flag to generate an interrupt request. The CF bit is not automatically cleared by hardware when the CPU vectors to the interrupt service routine, and must be cleared by software (Note: PCA0 interrupts must be globally enabled before CF interrupts are recognized. PCA0 interrupts are globally enabled by setting the EA bit (IE.7) and the EPCA0 bit in EIE1 to logic 1). Clearing the CIDL bit in the PCA0MD register allows the PCA to continue normal operation while the CPU is in Idle mode.

**Table 20.1. PCA Timebase Input Options**

CPS2	CPS1	CPS0	Timebase
0	0	0	System clock divided by 12
0	0	1	System clock divided by 4
0	1	0	Timer 0 overflow
0	1	1	High-to-low transitions on ECI (max rate = system clock divided by 4)
1	0	0	System clock
1	0	1	External oscillator source divided by 8 <sup>†</sup>

<sup>†</sup>External oscillator source divided by 8 is synchronized with the system clock.

**Figure 20.2. PCA Counter/Timer Block Diagram**



## 20.2. Capture/Compare Modules

Each module can be configured to operate independently in one of six operation modes: Edge-triggered Capture, Software Timer, High Speed Output, Frequency Output, 8-Bit Pulse Width Modulator, or 16-Bit Pulse Width Modulator. Each module has Special Function Registers (SFRs) associated with it in the CIP-51 system controller. These registers are used to exchange data with a module and configure the module's mode of operation.

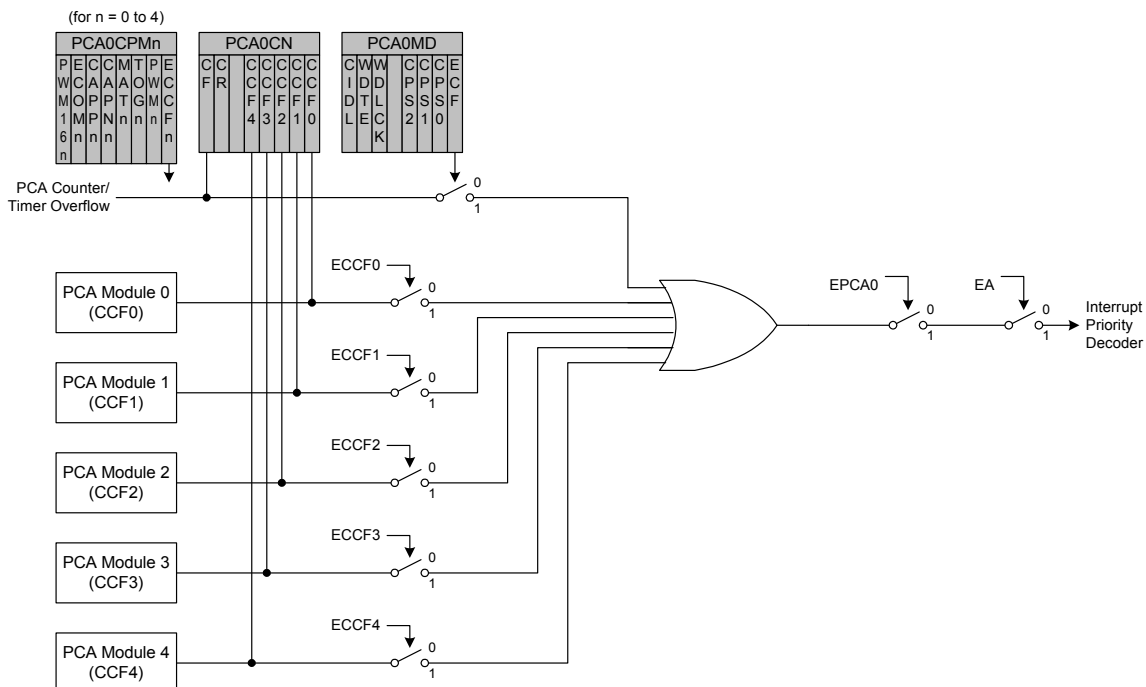
Table 20.2 summarizes the bit settings in the PCA0CPMn registers used to select the PCA capture/compare module's operating modes. Setting the ECCFn bit in a PCA0CPMn register enables the module's CCFn interrupt. Note: PCA0 interrupts must be globally enabled before individual CCFn interrupts are recognized. PCA0 interrupts are globally enabled by setting the EA bit and the EPCA0 bit to logic 1. See Figure 20.3 for details on the PCA interrupt configuration.

**Table 20.2. PCA0CPM Register Settings for PCA Capture/Compare Modules**

PWM16	ECOM	CAPP	CAPN	MAT	TOG	PWM	ECCF	Operation Mode
X	X	1	0	0	0	0	X	Capture triggered by positive edge on CEXn
X	X	0	1	0	0	0	X	Capture triggered by negative edge on CEXn
X	X	1	1	0	0	0	X	Capture triggered by transition on CEXn
X	1	0	0	1	0	0	X	Software Timer
X	1	0	0	1	1	0	X	High Speed Output
X	1	0	0	X	1	1	X	Frequency Output
0	1	0	0	X	0	1	X	8-Bit Pulse Width Modulator
1	1	0	0	X	0	1	X	16-Bit Pulse Width Modulator

X = Don't Care

**Figure 20.3. PCA Interrupt Block Diagram**



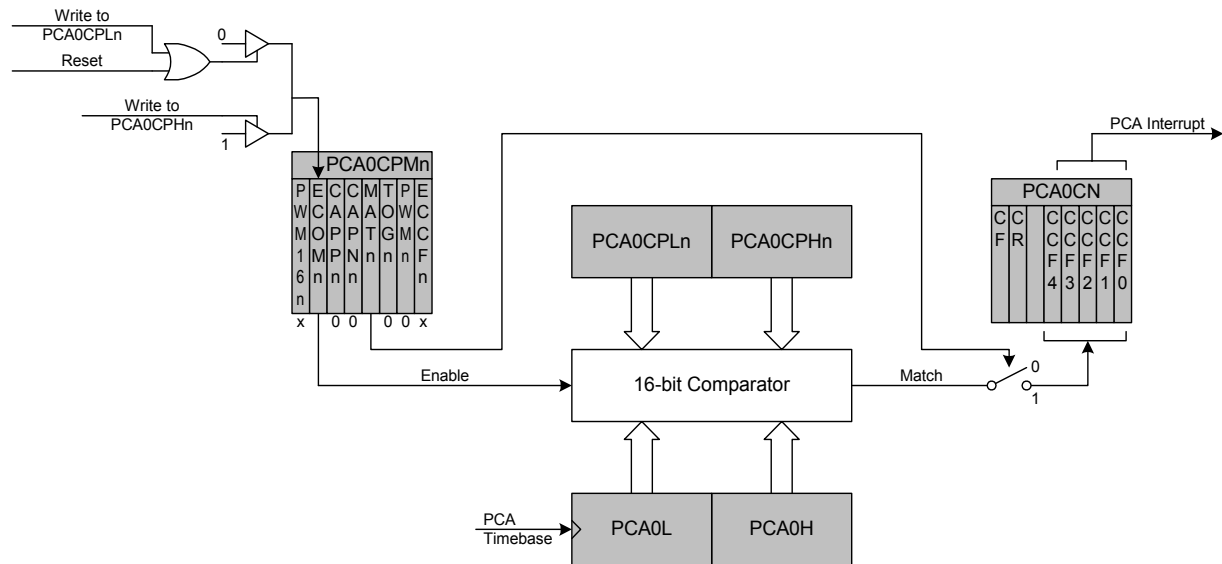


## 20.2.2. Software Timer (Compare) Mode

In Software Timer mode, the PCA counter/timer value is compared to the module's 16-bit capture/compare register (PCA0CPHn and PCA0CPLn). When a match occurs, the Capture/Compare Flag (CCFn) in PCA0CN is set to logic 1 and an interrupt request is generated if CCF interrupts are enabled. The CCFn bit is not automatically cleared by hardware when the CPU vectors to the interrupt service routine, and must be cleared by software. Setting the ECOMn and MATn bits in the PCA0CPMn register enables Software Timer mode.

**Important Note About Capture/Compare Registers:** When writing a 16-bit value to the PCA0 Capture/Compare registers, the low byte should always be written first. Writing to PCA0CPLn clears the ECOMn bit to '0'; writing to PCA0CPHn sets ECOMn to '1'.

**Figure 20.5. PCA Software Timer Mode Diagram**

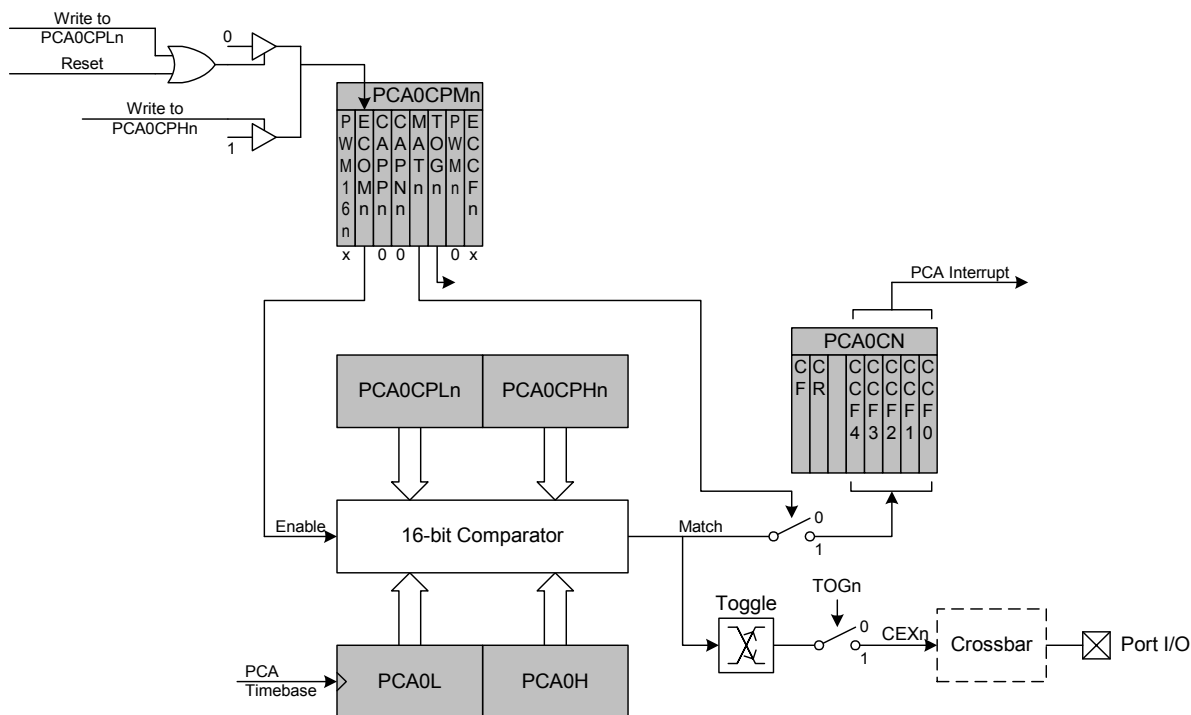


## 20.2.3. High Speed Output Mode

In High Speed Output mode, a module's associated CEXn pin is toggled each time a match occurs between the PCA Counter and the module's 16-bit capture/compare register (PCA0CPHn and PCA0CPLn). Setting the TOGn, MATn, and ECOMn bits in the PCA0CPMn register enables the High-Speed Output mode.

**Important Note About Capture/Compare Registers:** When writing a 16-bit value to the PCA0 Capture/Compare registers, the low byte should always be written first. Writing to PCA0CPLn clears the ECOMn bit to '0'; writing to PCA0CPHn sets ECOMn to '1'.

**Figure 20.6. PCA High Speed Output Mode Diagram**





## 20.2.4. Frequency Output Mode

Frequency Output Mode produces a programmable-frequency square wave on the module's associated CEXn pin. The capture/compare module high byte holds the number of PCA clocks to count before the output is toggled. The frequency of the square wave is then defined by Equation 20.1.

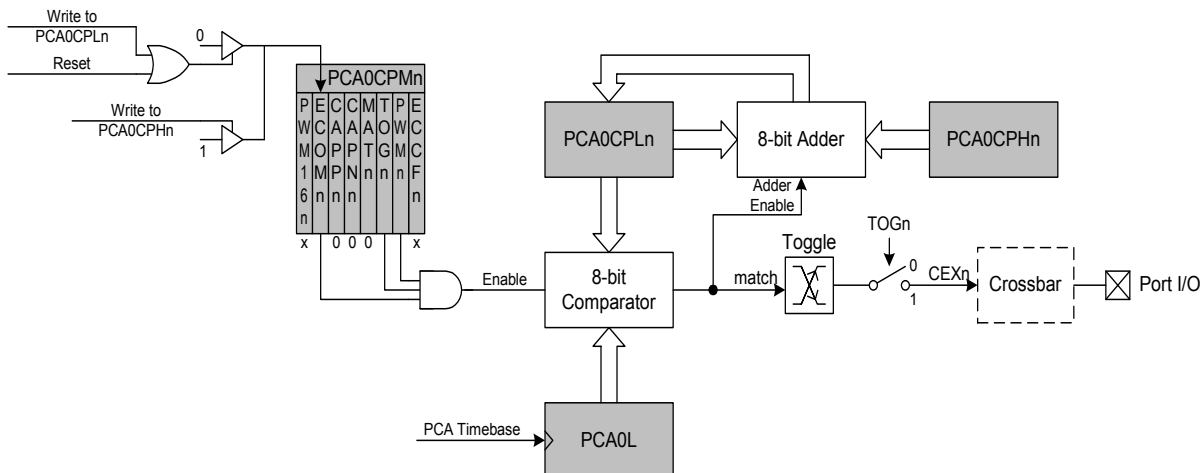
### Equation 20.1. Square Wave Frequency Output

$$F_{CEXn} = \frac{F_{PCA}}{2 \times PCA0CPHn}$$

Note: A value of 0x00 in the PCA0CPHn register is equal to 256 for this equation.

Where  $F_{PCA}$  is the frequency of the clock selected by the CPS2-0 bits in the PCA mode register, PCA0MD. The lower byte of the capture/compare module is compared to the PCA counter low byte; on a match, CEXn is toggled and the offset held in the high byte is added to the matched value in PCA0CPLn. Frequency Output Mode is enabled by setting the ECOMn, TOGn, and PWMn bits in the PCA0CPMn register.

**Figure 20.7. PCA Frequency Output Mode**



## 20.2.5. 8-Bit Pulse Width Modulator Mode

Each module can be used independently to generate a pulse width modulated (PWM) output on its associated CEXn pin. The frequency of the output is dependent on the timebase for the PCA counter/timer. The duty cycle of the PWM output signal is varied using the module's PCA0CPLn capture/compare register. When the value in the low byte of the PCA counter/timer (PCA0L) is equal to the value in PCA0CPLn, the output on the CEXn pin will be set. When the count value in PCA0L overflows, the CEXn output will be reset (see Figure 20.8). Also, when the counter/timer low byte (PCA0L) overflows from 0xFF to 0x00, PCA0CPLn is reloaded automatically with the value stored in the module's capture/compare high byte (PCA0CPHn) without software intervention. Setting the ECOMn and PWMn bits in the PCA0CPMn register enables 8-Bit Pulse Width Modulator mode. The duty cycle for 8-Bit PWM Mode is given by Equation 20.2.

**Important Note About Capture/Compare Registers:** When writing a 16-bit value to the PCA0 Capture/Compare registers, the low byte should always be written first. Writing to PCA0CPLn clears the ECOMn bit to '0'; writing to PCA0CPHn sets ECOMn to '1'.

### Equation 20.2. 8-Bit PWM Duty Cycle

$$DutyCycle = \frac{(256 - PCA0CPHn)}{256}$$







## 20.3. Watchdog Timer Mode

A programmable watchdog timer (WDT) function is available through the PCA Module 4. The WDT is used to generate a reset if the time between writes to the WDT update register (PCA0CPH4) exceed a specified limit. The WDT can be configured and enabled/disabled as needed by software.

With the WDTE and/or WDLCK bits set to ‘1’ in the PCA0MD register, Module 4 operates as a watchdog timer (WDT). The Module 4 high byte is compared to the PCA counter high byte; the Module 4 low byte holds the offset to be used when WDT updates are performed. **The Watchdog Timer is enabled on reset. Writes to some PCA registers are restricted while the Watchdog Timer is enabled.**

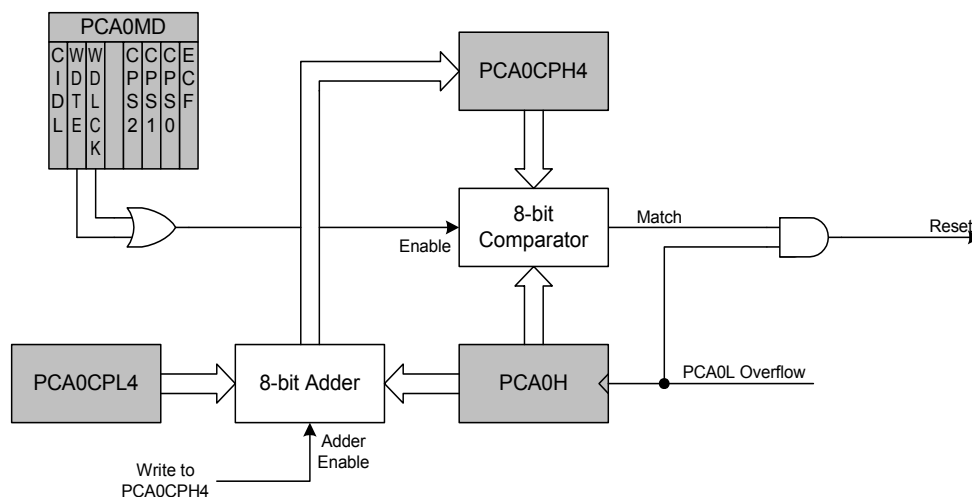
### 20.3.1. Watchdog Timer Operation

While the WDT is enabled:

- PCA counter is forced on.
- Writes to PCA0L and PCA0H are not allowed.
- PCA clock source bits (CPS2-CPS0) are frozen.
- PCA Idle control bit (CIDL) is frozen.
- Module 4 is forced into Watchdog Timer mode.
- Writes to the Module 4 mode register (PCA0CPM4) are disabled.

While the WDT is enabled, writes to the CR bit will not change the PCA counter state; the counter will run until the WDT is disabled. The PCA counter run control (CR) will read zero if the WDT is enabled but user software has not enabled the PCA counter. If a match occurs between PCA0CPH4 and PCA0H while the WDT is enabled, a reset will be generated. To prevent a WDT reset, the WDT may be updated with a write of any value to PCA0CPH4. Upon a PCA0CPH4 write, PCA0H plus the offset held in PCA0CPL4 is loaded into PCA0CPH4 (See Figure 20.10).

**Figure 20.10. PCA Module 4 with Watchdog Timer Enabled**



Note that the 8-bit offset held in PCA0CPH4 is compared to the upper byte of the 16-bit PCA counter. This offset value is the number of PCA0L overflows before a reset. Up to 256 PCA clocks may pass before the first PCA0L overflow occurs, depending on the value of the PCA0L when the update is performed. The total offset is then given (in PCA clocks) by Equation 20.4, where PCA0L is the value of the PCA0L register at the time of the update.

### Equation 20.4. Watchdog Timer Offset in PCA Clocks

$$Offset = (256 \times PCA0CPL4) + (256 - PCA0L)$$

The WDT reset is generated when PCA0L overflows while there is a match between PCA0CPH4 and PCA0H. Software may force a WDT reset by writing a '1' to the CCF4 flag (PCA0CN.4) while the WDT is enabled.

#### 20.3.2. Watchdog Timer Usage

To configure the WDT, perform the following tasks:

1. Disable the WDT by writing a '0' to the WDTE bit.
2. Select the desired PCA clock source (with the CPS2-CPS0 bits).
3. Load PCA0CPL4 with the desired WDT update offset value.
4. Configure the PCA Idle mode (set CIDL if the WDT should be suspended while the CPU is in Idle mode).
5. Enable the WDT by setting the WDTE bit to '1'.
6. (optional) Lock the WDT (prevent WDT disable until the next system reset) by setting the WDLCK bit to '1'.

The PCA clock source and Idle mode select cannot be changed while the WDT is enabled. The watchdog timer is enabled by setting the WDTE or WDLCK bits in the PCA0MD register. When WDLCK is set, the WDT cannot be disabled until the next system reset. If WDLCK is not set, the WDT is disabled by clearing the WDTE bit.

The WDT is enabled following any reset. The PCA0 counter clock defaults to the system clock divided by 12, PCA0L defaults to 0x00, and PCA0CPL4 defaults to 0x00. Using Equation 20.4, this results in a WDT timeout interval of 256 system clock cycles. Table 20.3 lists some example timeout intervals for typical system clocks.

**Table 20.3. Watchdog Timer Timeout Intervals<sup>†</sup>**

System Clock (Hz)	PCA0CPL4	Timeout Interval (ms)
12,000,000	255	65.5
12,000,000	128	33.0
12,000,000	32	8.4
18,432,000	255	42.7
18,432,000	128	21.5
18,432,000	32	5.5
11,059,200	255	71.1
11,059,200	128	35.8
11,059,200	32	9.2
4,000,000	255	196.6
4,000,000	128	99.1
4,000,000	32	25.3
32,000	255	24,576.0
32,000	128	12,384.0
32,000	32	3,168.0

<sup>†</sup>Assumes SYSCLK / 12 as the PCA clock source, and a PCA0L value of 0x00 at the update time.

<sup>††</sup>Internal oscillator reset frequency.

## 20.4. Register Descriptions for PCA

Following are detailed descriptions of the special function registers related to the operation of the PCA.

**Figure 20.11. PCA0CN: PCA Control Register**

R/W	R/W	R/W	R/W	R/W	R/W	R/W	R/W	Reset Value
CF	CR	-	CCF4	CCF3	CCF2	CCF1	CCF0	00000000
Bit7	Bit6	Bit5	Bit4	Bit3	Bit2	Bit1	Bit0	SFR Address: (bit addressable) 0xD8

Bit7: CF: PCA Counter/Timer Overflow Flag.  
Set by hardware when the PCA Counter/Timer overflows from 0xFFFF to 0x0000. When the Counter/Timer Overflow (CF) interrupt is enabled, setting this bit causes the CPU to vector to the PCA interrupt service routine. This bit is not automatically cleared by hardware and must be cleared by software.

Bit6: CR: PCA Counter/Timer Run Control.  
This bit enables/disables the PCA Counter/Timer.  
0: PCA Counter/Timer disabled.  
1: PCA Counter/Timer enabled.

Bit5: UNUSED. Read = 0b, Write = don't care.

Bit4: CCF4: PCA Module 4 Capture/Compare Flag.  
This bit is set by hardware when a match or capture occurs. When the CCF4 interrupt is enabled, setting this bit causes the CPU to vector to the PCA interrupt service routine. This bit is not automatically cleared by hardware and must be cleared by software.

Bit3: CCF3: PCA Module 3 Capture/Compare Flag.  
This bit is set by hardware when a match or capture occurs. When the CCF3 interrupt is enabled, setting this bit causes the CPU to vector to the PCA interrupt service routine. This bit is not automatically cleared by hardware and must be cleared by software.

Bit2: CCF2: PCA Module 2 Capture/Compare Flag.  
This bit is set by hardware when a match or capture occurs. When the CCF2 interrupt is enabled, setting this bit causes the CPU to vector to the PCA interrupt service routine. This bit is not automatically cleared by hardware and must be cleared by software.

Bit1: CCF1: PCA Module 1 Capture/Compare Flag.  
This bit is set by hardware when a match or capture occurs. When the CCF1 interrupt is enabled, setting this bit causes the CPU to vector to the PCA interrupt service routine. This bit is not automatically cleared by hardware and must be cleared by software.

Bit0: CCF0: PCA Module 0 Capture/Compare Flag.  
This bit is set by hardware when a match or capture occurs. When the CCF0 interrupt is enabled, setting this bit causes the CPU to vector to the PCA interrupt service routine. This bit is not automatically cleared by hardware and must be cleared by software.



**Figure 20.12. PCA0MD: PCA Mode Register**

R/W	R/W	R/W	R/W	R/W	R/W	R/W	R/W	Reset Value
CIDL	WDTE	WDLCK	-	CPS2	CPS1	CPS0	ECF	01000000
Bit7	Bit6	Bit5	Bit4	Bit3	Bit2	Bit1	Bit0	SFR Address: 0xD9

Bit7: CIDL: PCA Counter/Timer Idle Control.  
Specifies PCA behavior when CPU is in Idle Mode.  
0: PCA continues to function normally while the system controller is in Idle Mode.  
1: PCA operation is suspended while the system controller is in Idle Mode.

Bit6: WDTE: Watchdog Timer Enable  
If this bit is set, PCA Module 4 is used as the watchdog timer.  
0: Watchdog Timer disabled.  
1: PCA Module 4 enabled as Watchdog Timer.

Bit5: WDLCK: Watchdog Timer Lock  
This bit enables and locks the Watchdog Timer. When WDLCK is set to '1', the Watchdog Timer may not be disabled until the next system reset.  
0: Watchdog Timer unlocked.  
1: Watchdog Timer enabled and locked.

Bit4: UNUSED. Read = 0b, Write = don't care.

Bits3-1: CPS2-CPS0: PCA Counter/Timer Pulse Select.  
These bits select the timebase source for the PCA counter.

CPS2	CPS1	CPS0	Timebase
0	0	0	System clock divided by 12
0	0	1	System clock divided by 4
0	1	0	Timer 0 overflow
0	1	1	High-to-low transitions on ECI (max rate = system clock divided by 4)
1	0	0	System clock
1	0	1	External clock divided by 8 <sup>†</sup>
1	1	0	Reserved
1	1	1	Reserved

<sup>†</sup>External oscillator source divided by 8 is synchronized with the system clock.

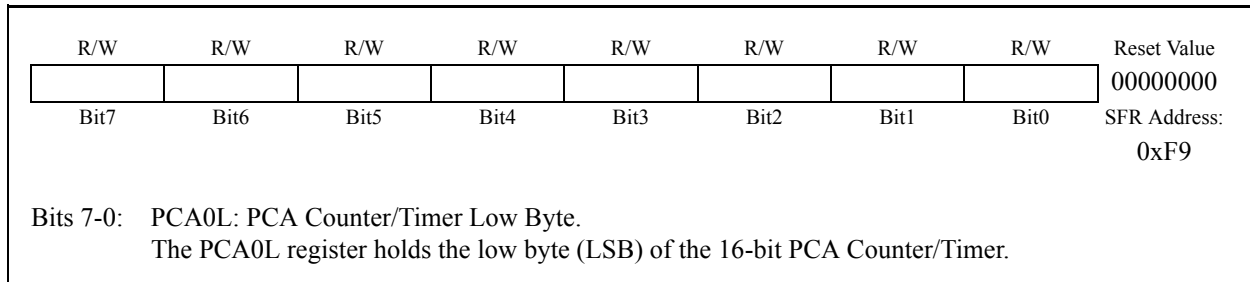
Bit0: ECF: PCA Counter/Timer Overflow Interrupt Enable.  
This bit sets the masking of the PCA Counter/Timer Overflow (CF) interrupt.  
0: Disable the CF interrupt.  
1: Enable a PCA Counter/Timer Overflow interrupt request when CF (PCA0CN.7) is set.

**Note: When the WDTE bit is set to '1', the PCA0MD register cannot be modified. To change the contents of the PCA0MD register, the Watchdog Timer must first be disabled.**

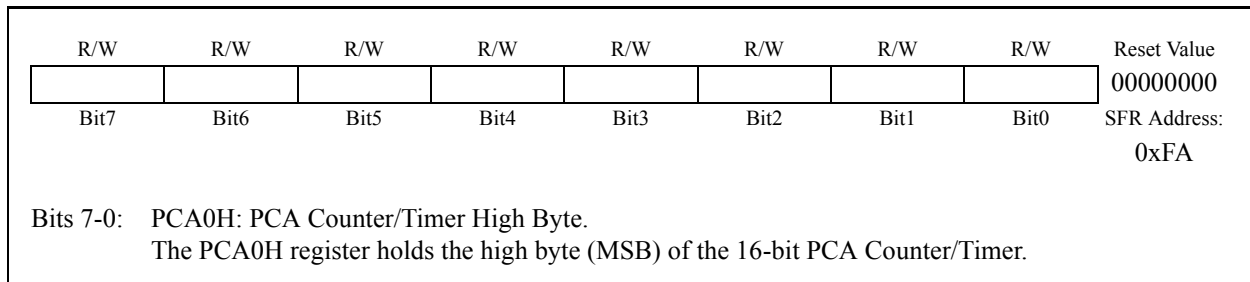
**Figure 20.13. PCA0CPMn: PCA Capture/Compare Mode Registers**

R/W	R/W	R/W	R/W	R/W	R/W	R/W	R/W	Reset Value
PWM16n	ECOMn	CAPPn	CAPNn	MATn	TOGn	PWMn	EECFn	00000000
Bit7	Bit6	Bit5	Bit4	Bit3	Bit2	Bit1	Bit0	SFR Address: 0xDA, 0xDB, 0xDC, 0xDD, 0xDE
PCA0CPMn Address:		PCA0CPM0 = 0xDA (n = 0), PCA0CPM1 = 0xDB (n = 1), PCA0CPM2 = 0xDC (n = 2), PCA0CPM3 = 0xDD (n = 3), PCA0CPM4 = 0xDE (n = 4)						
Bit7:	PWM16n: 16-bit Pulse Width Modulation Enable. This bit selects 16-bit mode when Pulse Width Modulation mode is enabled (PWMn = 1). 0: 8-bit PWM selected. 1: 16-bit PWM selected.							
Bit6:	ECOMn: Comparator Function Enable. This bit enables/disables the comparator function for PCA module n. 0: Disabled. 1: Enabled.							
Bit5:	CAPPn: Capture Positive Function Enable. This bit enables/disables the positive edge capture for PCA module n. 0: Disabled. 1: Enabled.							
Bit4:	CAPNn: Capture Negative Function Enable. This bit enables/disables the negative edge capture for PCA module n. 0: Disabled. 1: Enabled.							
Bit3:	MATn: Match Function Enable. This bit enables/disables the match function for PCA module n. When enabled, matches of the PCA counter with a module's capture/compare register cause the CCFn bit in PCA0MD register to be set to logic 1. 0: Disabled. 1: Enabled.							
Bit2:	TOGn: Toggle Function Enable. This bit enables/disables the toggle function for PCA module n. When enabled, matches of the PCA counter with a module's capture/compare register cause the logic level on the CEXn pin to toggle. If the PWMn bit is also set to logic 1, the module operates in Frequency Output Mode. 0: Disabled. 1: Enabled.							
Bit1:	PWMn: Pulse Width Modulation Mode Enable. This bit enables/disables the PWM function for PCA module n. When enabled, a pulse width modulated signal is output on the CEXn pin. 8-bit PWM is used if PWM16n is cleared; 16-bit mode is used if PWM16n is set to logic 1. If the TOGn bit is also set, the module operates in Frequency Output Mode. 0: Disabled. 1: Enabled.							
Bit0:	EECFn: Capture/Compare Flag Interrupt Enable. This bit sets the masking of the Capture/Compare Flag (CCFn) interrupt. 0: Disable CCFn interrupts. 1: Enable a Capture/Compare Flag interrupt request when CCFn is set.							

**Figure 20.14. PCA0L: PCA Counter/Timer Low Byte**



**Figure 20.15. PCA0H: PCA Counter/Timer High Byte**



**Figure 20.16. PCA0CPLn: PCA Capture Module Low Byte**

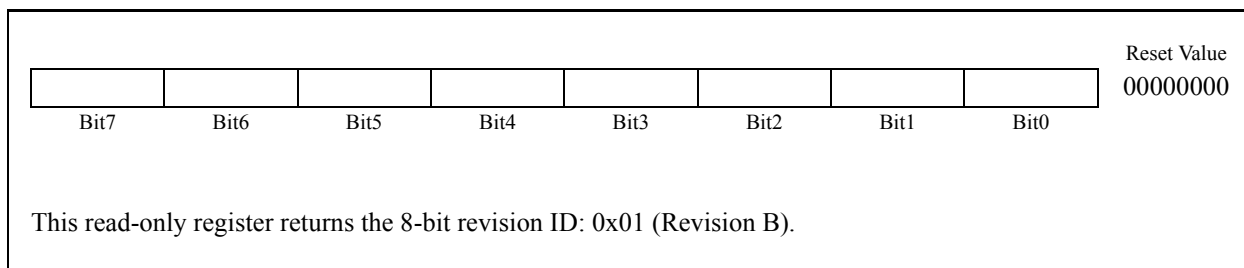
R/W	R/W	R/W	R/W	R/W	R/W	R/W	R/W	Reset Value
								00000000
Bit7	Bit6	Bit5	Bit4	Bit3	Bit2	Bit1	Bit0	SFR Address: 0xFB, 0xE9, 0xEB, 0xED, 0xFD
<p>PCA0CPLn Address:      PCA0CPL0 = 0xFB (n = 0), PCA0CPL1 = 0xE9 (n = 1),  PCA0CPL2 = 0xEB (n = 2), PCA0CPL3 = 0xED (n = 3),  PCA0CPL4 = 0xFD (n = 4)</p> <p>Bits7-0:    PCA0CPLn: PCA Capture Module Low Byte.  The PCA0CPLn register holds the low byte (LSB) of the 16-bit capture module n.</p>								

**Figure 20.17. PCA0CPHn: PCA Capture Module High Byte**

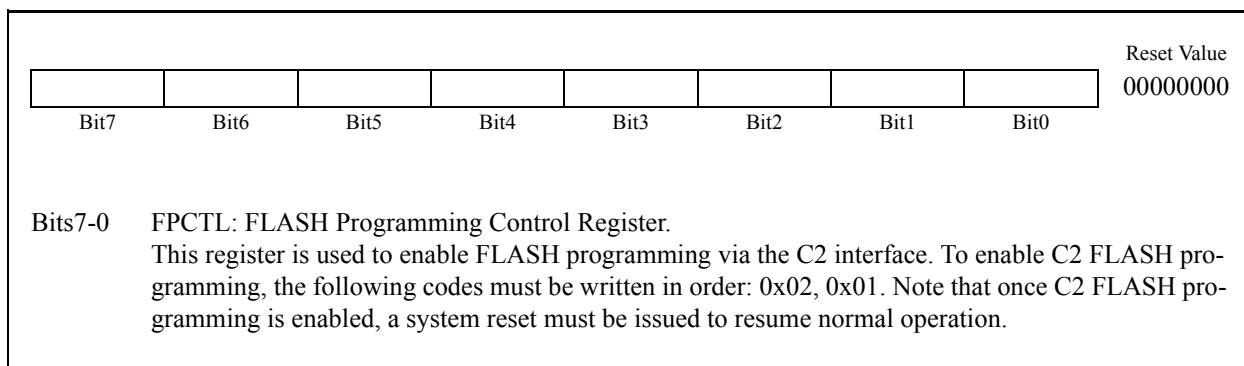
R/W	R/W	R/W	R/W	R/W	R/W	R/W	R/W	Reset Value
								00000000
Bit7	Bit6	Bit5	Bit4	Bit3	Bit2	Bit1	Bit0	SFR Address: 0xFC, 0xEA, 0xEC, 0xEE, 0xFE
<p>PCA0CPHn Address:      PCA0CPH0 = 0xFC (n = 0), PCA0CPH1 = 0xEA (n = 1),  PCA0CPH2 = 0xEC (n = 2), PCA0CPH3 = 0xEE (n = 3),  PCA0CPH4 = 0xFE (n = 4)</p> <p>Bits7-0:    PCA0CPHn: PCA Capture Module High Byte.  The PCA0CPHn register holds the high byte (MSB) of the 16-bit capture module n.</p>								



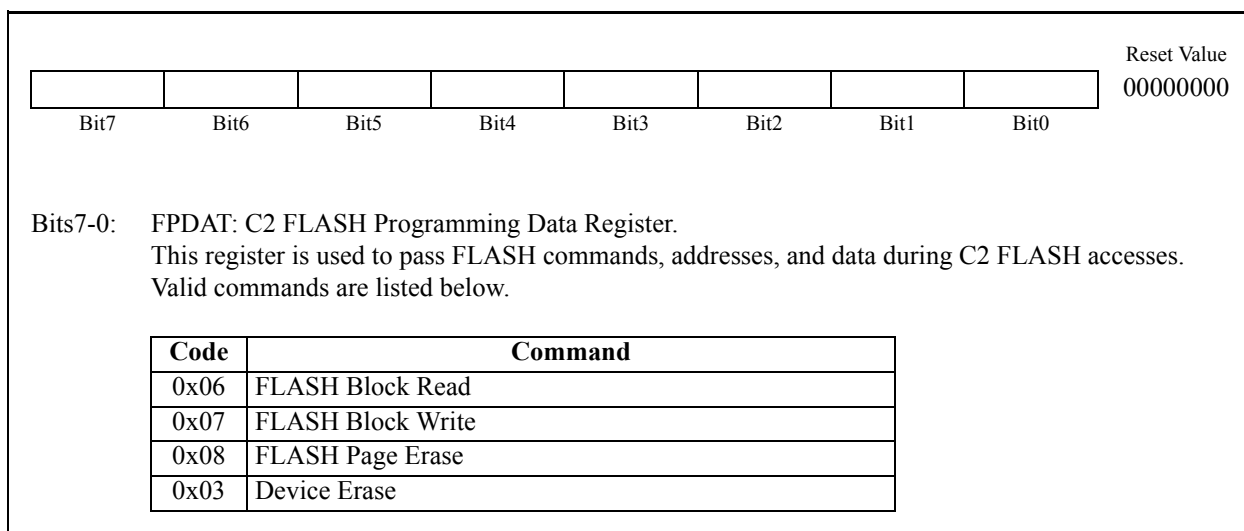
**Figure 21.3. REVID: C2 Revision ID Register**



**Figure 21.4. FPCTL: C2 FLASH Programming Control Register**



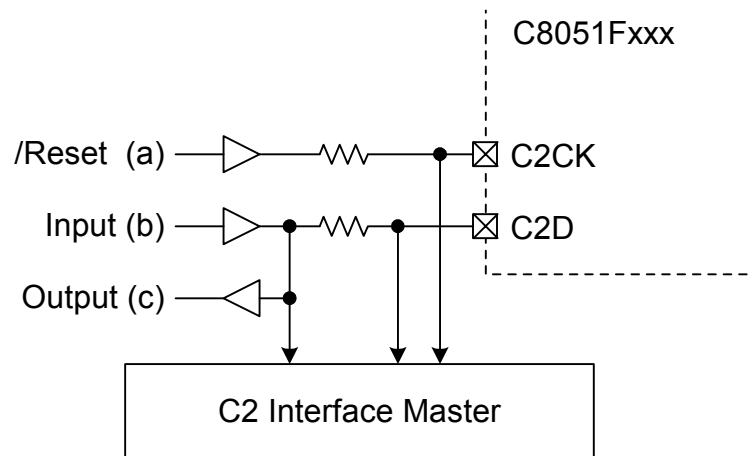
**Figure 21.5. FPDAT: C2 FLASH Programming Data Register**



## 21.2. C2 Pin Sharing

The C2 protocol allows the C2 pins to be shared with user functions so that in-system debugging, FLASH programming, and boundary scan functions may be performed. This is possible because C2 communication is typically performed when the device is in the halt state, where all on-chip peripherals and user software are stalled. In this halted state, the C2 interface can safely ‘borrow’ the C2CK (/RST) and C2D (P3.0) pins. In most applications, external resistors are required to isolate C2 interface traffic from the user application. A typical isolation configuration is shown in Figure 21.6.

**Figure 21.6. Typical C2 Pin Sharing**



The configuration in Figure 21.6 assumes the following:

1. The user input (b) cannot change state while the target device is halted.
2. The /RST pin on the target device is used as an input only.

Additional resistors may be necessary depending on the specific application.

## Contact Information

### Silicon Laboratories Inc.

4635 Boston Lane

Austin, TX 78735

Tel: 1+(512) 416-8500

Fax: 1+(512) 416-9669

Toll Free: 1+(877) 444-3032

Email: [productinfo@silabs.com](mailto:productinfo@silabs.com)

Internet: [www.silabs.com](http://www.silabs.com)

The information in this document is believed to be accurate in all respects at the time of publication but is subject to change without notice. Silicon Laboratories assumes no responsibility for errors and omissions, and disclaims responsibility for any consequences resulting from the use of information included herein. Additionally, Silicon Laboratories assumes no responsibility for the functioning of undescribed features or parameters. Silicon Laboratories reserves the right to make changes without further notice. Silicon Laboratories makes no warranty, representation or guarantee regarding the suitability of its products for any particular purpose, nor does Silicon Laboratories assume any liability arising out of the application or use of any product or circuit, and specifically disclaims any and all liability, including without limitation consequential or incidental damages. Silicon Laboratories products are not designed, intended, or authorized for use in applications intended to support or sustain life, or for any other application in which the failure of the Silicon Laboratories product could create a situation where personal injury or death may occur. Should Buyer purchase or use Silicon Laboratories products for any such unintended or unauthorized application, Buyer shall indemnify and hold Silicon Laboratories harmless against all claims and damages.

Silicon Laboratories and Silicon Labs are trademarks of Silicon Laboratories Inc.

Other products or brandnames mentioned herein are trademarks or registered trademarks of their respective holders