



DATA SHEET

SEMICONDUCTOR

DB101S THRU DB107S

Glass passivated type



FEATURES

- Plastic package has Underwriters Laboratory Flammability Classification 94V-O Utilizing Flame Retardant Epoxy Molding Compound.
- For surface mounted applications.
- Exceeds environmental standards of MIL-S-19500 /228
- High surge current capability
- Ideal for printed circuit board
- High temperature soldering : 260°C / 10 seconds at terminals
- Pb free product at available : 99% Sn above meet RoHS environment substance directive request

Mechanical data

- Case : Molded plastic, DFS
- Terminals : Solder plated, solderable per MIL-STD-750, Method 2026
- Polarity : Marked on body
- Mounting Position : Any
- Weight : 0.412 gram

SDIP

Unit : inch (mm)

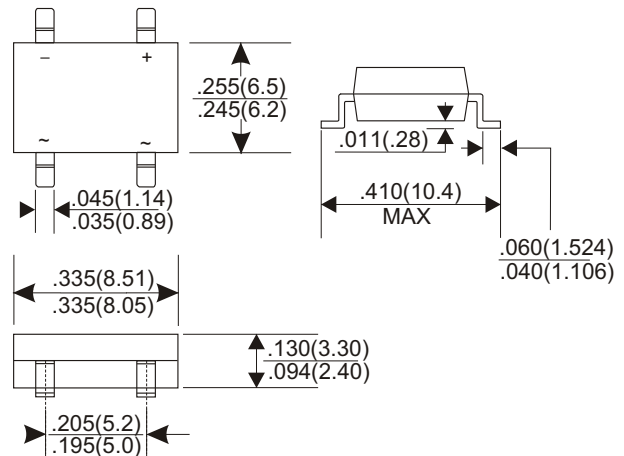

MAXIMUM RATINGS (AT TA=25oC unless otherwise noted)

- Rating 25 C ambient temperature unless otherwise specified.
- Single phase half wave, 60Hz, resistive or inductive load.
- For capacitive load, derate current by 20%.

PARAMETER	CONDITIONS	Symbol	MIN.	TYP.	MAX.	UNIT
Forward rectified current	See Fig.1	IO			1.0	A
Forward surge current	8.3ms single half sine-wave superimposed on rate load (JEDEC methode)	IFSM			50	A
Reverse current	VR = VRRM TA = 25oC	IR			10	uA
	VR = VRRM TA = 125oC				100	uA
Storage temperature		TSTG	-55		+150	

SYMBOLS	MARKING CODE	V RRM *1 (V)	V RMS *2 (V)	V R *3 (V)	V F *4 (V)	Operating temperature ()
DB101S	DB101S	50	35	50	1.1	-55 to +150
DB102S	DB102S	100	70	100		
DB103S	DB103S	200	140	200		
DB104S	DB104S	400	280	400		
DB105S	DB105S	600	420	600		
DB106S	DB106S	800	560	800		
DB107S	DB107S	1000	700	1000		

- 1 Repetitive peak reverse voltage
- 2 RMS voltage
- 3 Continuous reverse voltage
- 4 Maximum forward voltage

DEVICE CHARACTERISTICS

DB101S THRU DB107S

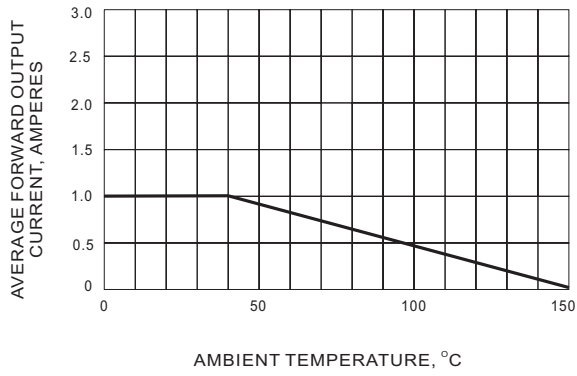

FIG.1 DERATING CURVE FOR OUTPUT RECTIFIED CURRENT

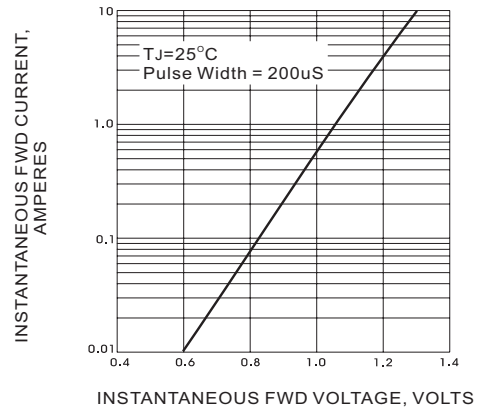

FIG.2 TYPICAL FORWARD CHARACTERISTICS

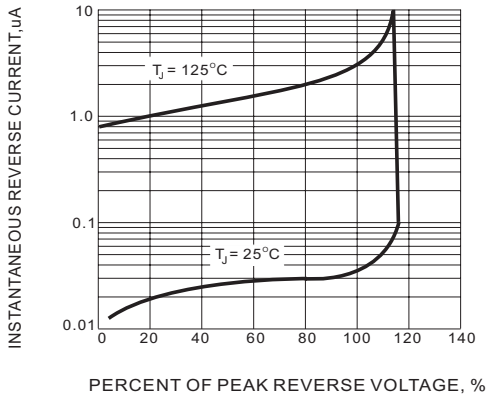

FIG.3 TYPICAL REVERSE CHARACTERISTICS

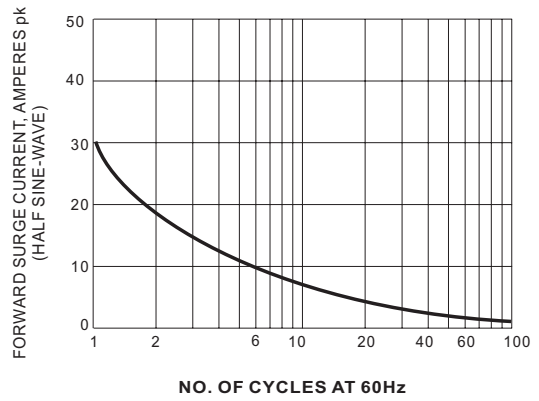

FIG.4 MAX NON-REPETITIVE SURGE CURRENT