



FEATURES

- Low cost
- Diffused junction
- Low leakage
- Low forward voltage drop
- High current capability
- Easily cleaned with alcohol, Isopropanol and similar solvents
- The plastic material carries U/L recognition 94V-0

MECHANICAL DATA

- Case: JEDEC DO-41, molded plastic
- Terminals: Axial lead, solderable per MIL-STD-202, Method 208
- Polarity: Color band denotes cathode
- Weight: 0.012 ounces, 0.34 grams
- Mounting position: Any

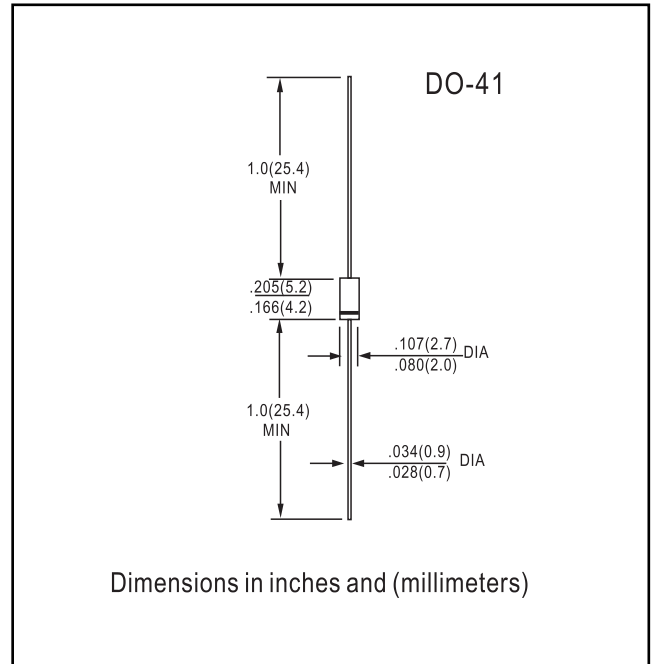

MAXIMUM RATINGS AND ELECTRICAL CHARACTERISTICS

Ratings at 25°C ambient temperature unless otherwise specified.

Single phase, half wave, 60 Hz, resistive or inductive load. For capacitive load, derate by 20%.

		ERA32 - 01	ERA32 - 02	UNITS
Maximum recurrent peak reverse voltage	V_{RRM}	100	200	V
Maximum RMS voltage	V_{RMS}	70	140	V
Maximum DC blocking voltage	V_{DC}	100	200	V
Maximum average forward rectified current 9.5mm lead length, @ $T_A=75^\circ C$	$I_{F(AV)}$	1.0		A
Peak forward surge current 8.3ms single half-sine-wave superimposed on rated load @ $T_J=125^\circ C$	I_{FSM}	40.0		A
Maximum instantaneous forward voltage @ 1.0A	V_F	0.92		V
Maximum reverse current @ $T_A=25^\circ C$ at rated DC blocking voltage @ $T_A=100^\circ C$	I_R	5.0	50.0	μA
Maximum reverse recovery time (Note1)	t_{rr}	50		ns
Typical junction capacitance (Note2)	C_J	20		pF
Typical thermal resistance (Note3)	$R_{\theta JA}$	60		$^\circ C/W$
Operating junction temperature range	T_J	- 55 ----- + 150		$^\circ C$
Storage temperature range	T_{STG}	- 55 ----- + 150		$^\circ C$

NOTE: 1. Measured with $I_F=0.5A$, $I_R=1A$, $I_{rr}=0.25A$.
 2. Measured at 1.0MHz and applied reverse voltage of 4.0V DC.
 3. Thermal resistance from junction to ambient.



RATINGS AND CHARACTERISTICS CURVES

ERA32-01 THRU ERA32-02

FIG.1-TEST CIRCUIT DIAGRAM AND REVERSE RECOVERY TIME CHARACTERISTIC

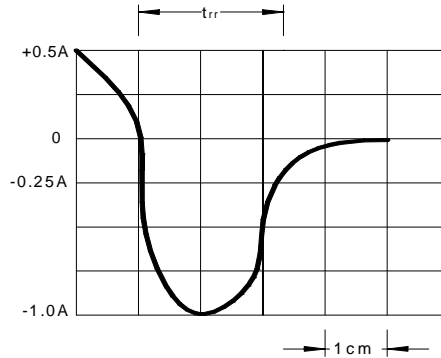
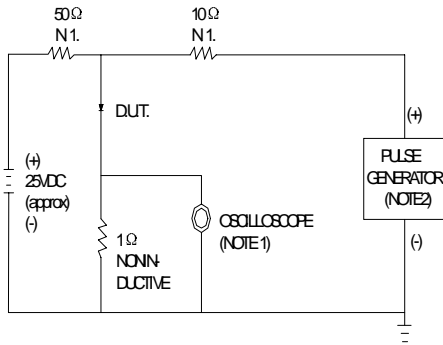
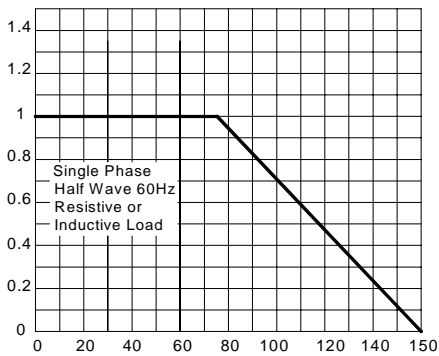

FIG.3 -FORWARD DERATING CURVE

AVERAGE FORWARD RECTIFIED CURRENT.
AMPERES



AMBIENT TEMPERATURE. °C

FIG.4-TYPICAL JUNCTION CAPACITANCE

JUNCTION CAPACITANCE,pF

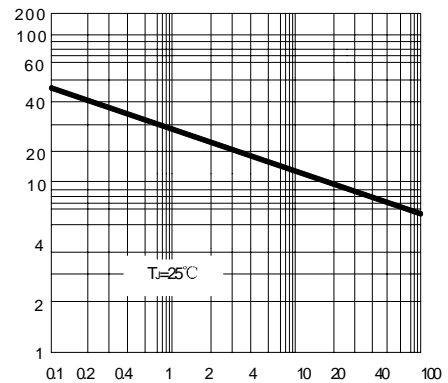

REVERSE VOLTAGE,VOLTS

FIG.5-PEAK FORWARD SURGE CURRENT

PEAK FORWARD SURGE CURRENT.
AMPERES

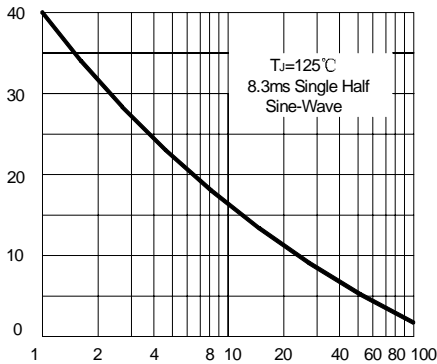

NUMBER OF CYCLES AT 60Hz

FIG.6 - TYPICAL FORWARD CHARACTERISTIC

INSTANTANEOUS FORWARD CURRENT
AMPERES

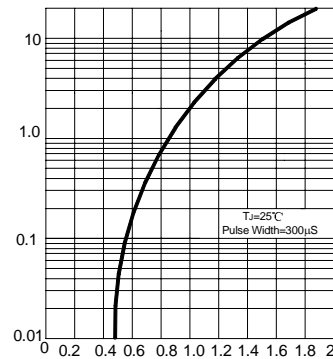

INSTANTANEOUS FORWARD VOLTAGE, VOLTS