

**APPLICATIONS**

Where transient overvoltage protection in esd sensitive equipment is required, such as :

- COMPUTERS
- PRINTERS
- COMMUNICATION SYSTEMS

It is particularly recommended for RS232 I/O port protection where the line interface withstands 2 kV, ESD surges.

**FEATURES**

- 18 BIDIRECTIONAL TRANSIL<sup>TM</sup> FUNCTIONS
- LOW CAPACITANCE : C = 30pF @ V<sub>RM</sub>
- 500 W peak pulse power (8/20 μs)

**DESCRIPTION**

The ESDA25DB3 is a dual monolithic voltage suppressor designed to protect components which are connected to data and transmission lines against ESD.

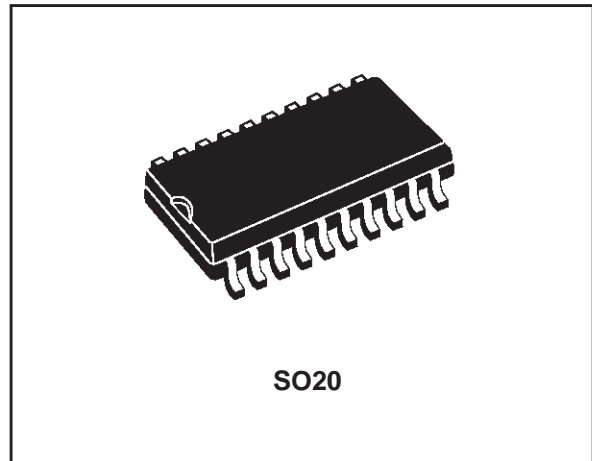
**BENEFITS**

- High ESD protection level : up to 25 kV
- High integration
- Suitable for high density boards

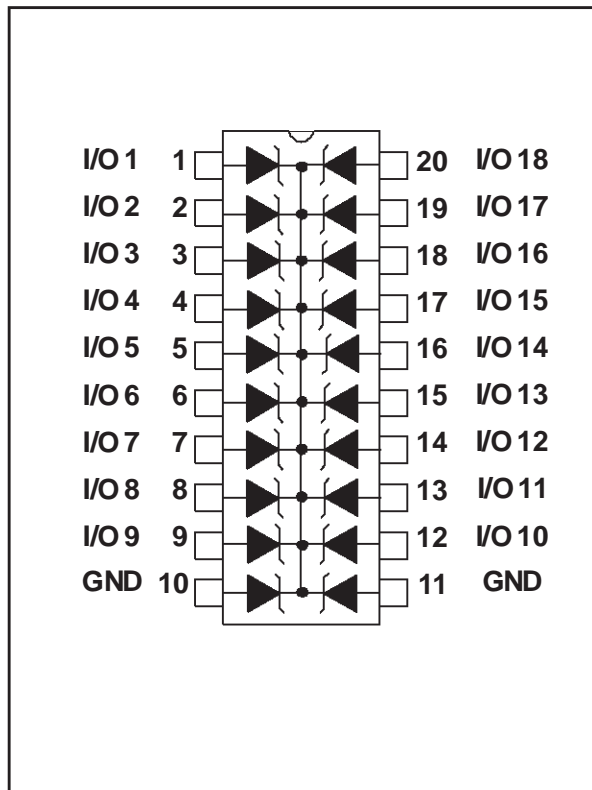
**COMPLIES WITH THE FOLLOWING STANDARDS :**

IEC 1000-4-2 : level 4

MIL STD 883C-Method 3015-6 : class 3  
(human body model)



**FUNCTIONAL DIAGRAM**



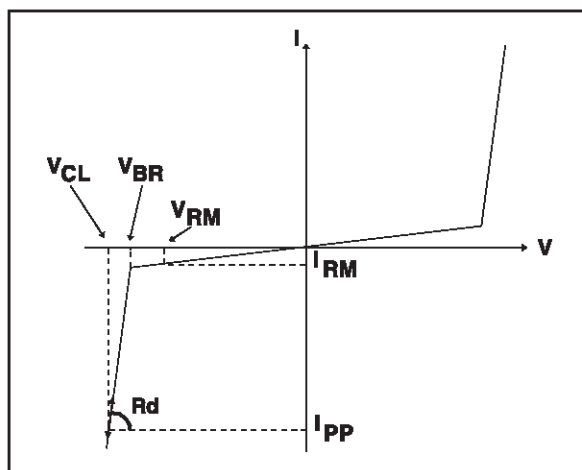
## ESDA25DB3

### ABSOLUTE MAXIMUM RATINGS ( $T_{amb} = 25^{\circ}\text{C}$ )

Symbol	Parameter	Value	Unit
$V_{PP}$	Electrostatic discharge MIL STD 883C - Method 3015-6	25	kV
$P_{PP}$	Peak pulse power (8/20 $\mu\text{s}$ )	500	W
$T_{stg}$ $T_j$	Storage temperature range Maximum junction temperature	- 55 to + 150 125	$^{\circ}\text{C}$ $^{\circ}\text{C}$
$T_L$	Maximum lead temperature for soldering during 10s	260	$^{\circ}\text{C}$

### ELECTRICAL CHARACTERISTICS ( $T_{amb} = 25^{\circ}\text{C}$ )

Symbol	Parameter
$V_{RM}$	Stand-off voltage
$V_{BR}$	Breakdown voltage
$V_{CL}$	Clamping voltage
$I_{RM}$	Leakage current
$I_{PP}$	Peak pulse current
$\alpha T$	Voltage temperature coefficient
C	Capacitance
$R_d$	Dynamic resistance



Types	$V_{BR}$ @		$I_R$	$I_{RM}$ @ $V_{RM}$		$R_d$ typ. note 2	$\alpha T$ max. note 3	C typ. 0V bias
	min.	max.		max.				
	note1			note1				
	V	V	mA	$\mu\text{A}$	V	$\Omega$	$10^{-4}/^{\circ}\text{C}$	pF
ESDA25DB3	25	30	1	2	24	0.5	9.7	50

note 1 : Between any I/O pin Ground

note 2 : Square pulse,  $I_{pp} = 25\text{A}$ ,  $t_p = 2.5\mu\text{s}$ .

note 3 :  $\Delta V_{BR} = \alpha T * (T_{amb} - 25^{\circ}\text{C}) * V_{BR}(25^{\circ}\text{C})$

## CALCULATION OF THE CLAMPING VOLTAGE

### USE OF THE DYNAMIC RESISTANCE

The ESDA family has been designed to clamp fast spikes like ESD. Generally the PCB designers need to calculate easily the clamping voltage  $V_{CL}$ . This is why we give the dynamic resistance in addition to the classical parameters. The voltage across the protection cell can be calculated with the following formula:

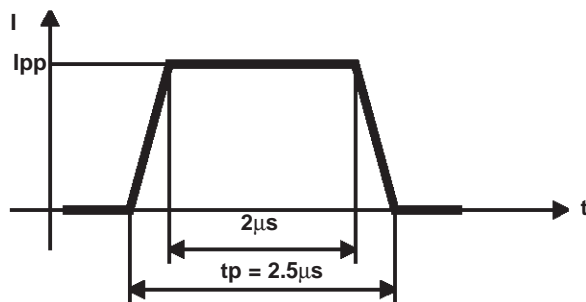
$$V_{CL} = V_{BR} + R_d I_{PP}$$

Where  $I_{PP}$  is the peak current through the ESDA cell.

As the value of the dynamic resistance remains stable for a surge duration lower than  $20\mu s$ , the  $2.5\mu s$  rectangular surge is well adapted. In addition both rise and fall times are optimized to avoid any parasitic phenomenon during the measurement of  $R_d$ .

### DYNAMIC RESISTANCE MEASUREMENT

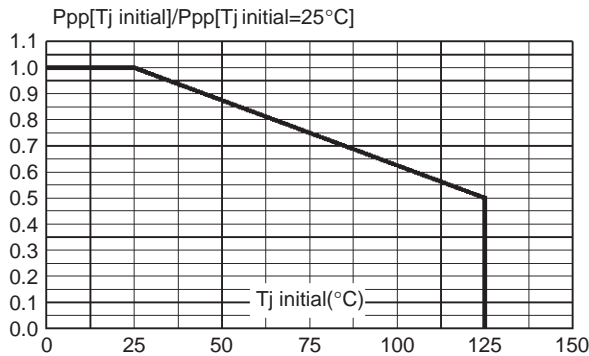
The short duration of the ESD has led us to prefer a more adapted test wave, as below defined, to the classical 8/20 $\mu s$  and 10/1000 $\mu s$  surges.



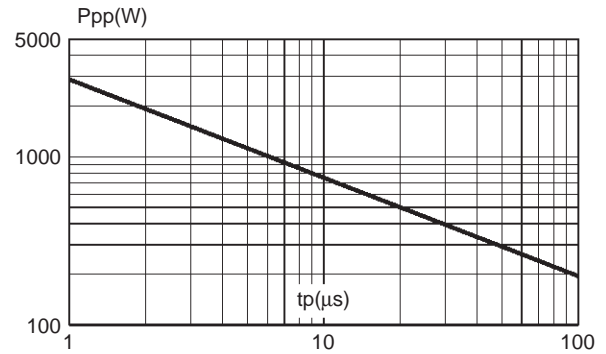
2.5 $\mu s$  duration measurement wave.

## ESDA25DB3

**Fig. 1 :** Peak power dissipation versus initial junction temperature.

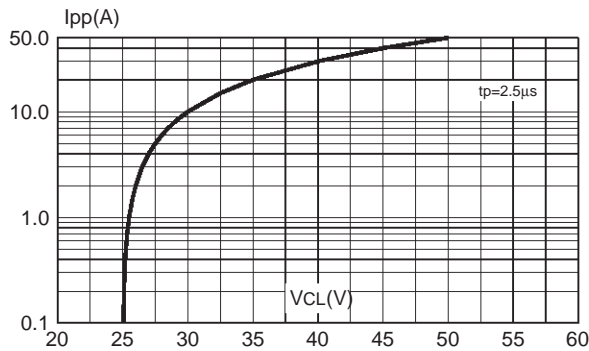


**Fig. 2 :** Peak pulse power versus exponential pulse duration ( $T_j \text{ initial} = 25^\circ\text{C}$ ).

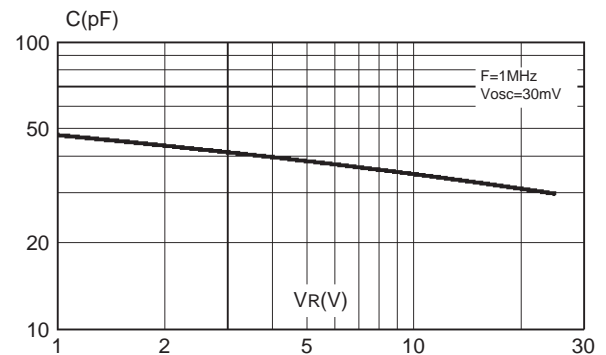


**Fig. 3 :** Clamping voltage versus peak pulse current ( $T_j \text{ initial} = 25^\circ\text{C}$ ).

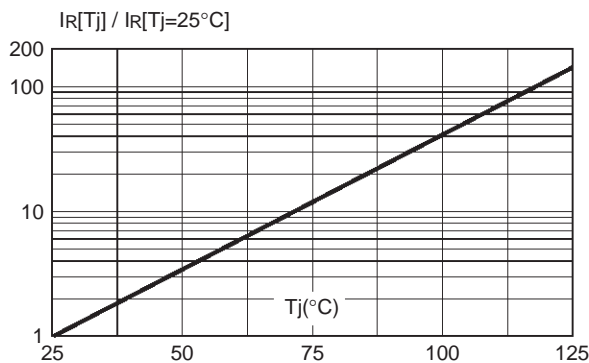
Rectangular waveform  $t_p = 2.5 \mu\text{s}$ .



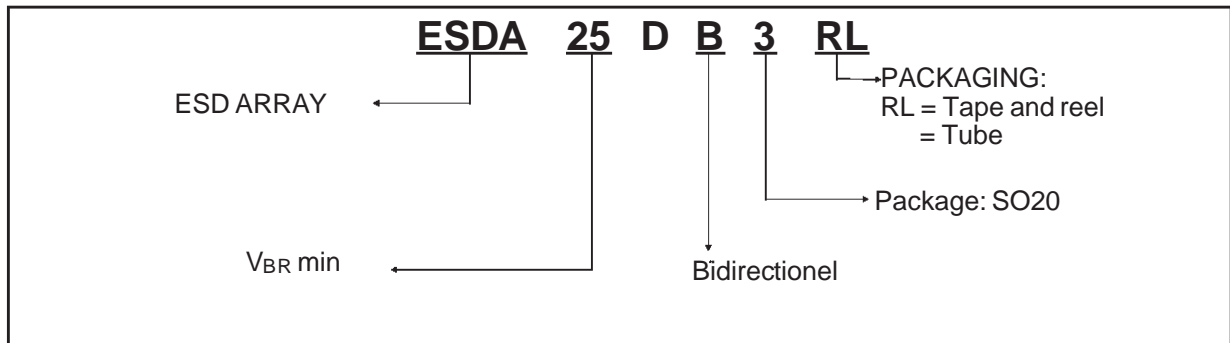
**Fig. 4 :** Capacitance versus reverse applied voltage (typical values).



**Fig. 5 :** Relative variation of leakage current versus junction temperature (typical values).



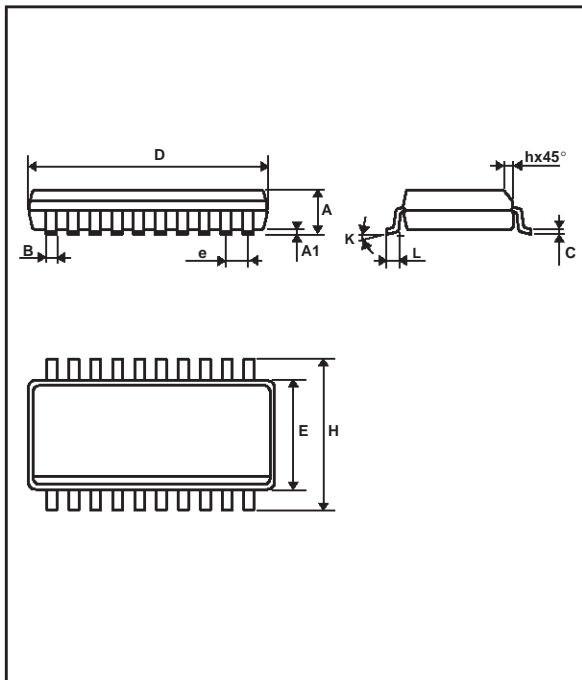
## ORDER CODE



**MARKING** : Logo, Date Code, E25DB3

## PACKAGE MECHANICAL DATA

SO20 Plastic



REF.	DIMENSIONS					
	Millimetres			Inches		
	Min.	Typ.	Max.	Min.	Typ.	Max.
A			2.65			0.104
A1	0.10		0.20	0.004		0.008
B	0.33		0.51	0.013		0.020
C	0.23		0.32	0.009		0.013
D	12.6		13.0	0.484		0.512
E	7.40		7.60	0.291		0.299
e		1.27			0.050	
H	10.0		10.65	0.394		0.419
h		0.50			0.020	
L	0.50		1.27	0.020		0.050
K	8° (max)					

**Packaging** : Preferred packaging is tape and reel.

**Weight** : 0.55g.

Information furnished is believed to be accurate and reliable. However, SGS-THOMSON Microelectronics assumes no responsibility for the consequences of use of such information nor for any infringement of patents or other rights of third parties which may result from its use. No license is granted by implication or otherwise under any patent or patent rights of SGS-THOMSON Microelectronics. Specifications mentioned in this publication are subject to change without notice. This publication supersedes and replaces all information previously supplied. SGS-THOMSON Microelectronics products are not authorized for use as critical components in life support devices or systems without express written approval of SGS-THOMSON Microelectronics.

© 1998 SGS-THOMSON Microelectronics - Printed in Italy - All rights reserved.

SGS-THOMSON Microelectronics GROUP OF COMPANIES

Australia - Brazil - Canada - China - France - Germany - Italy - Japan - Korea - Malaysia - Malta - Morocco  
The Netherlands - Singapore - Spain - Sweden - Switzerland - Taiwan - Thailand - United Kingdom - U.S.A.