

SCHOTTKY BARRIER DIODE

Features

- Low forward current
- High breakdown voltage
- Guard ring protected
- Low diode capacitance.
- S- Prefix for Automotive and Other Applications Requiring Unique Site and Control Change Requirements; AEC-Q101 Qualified and PPAP Capable.

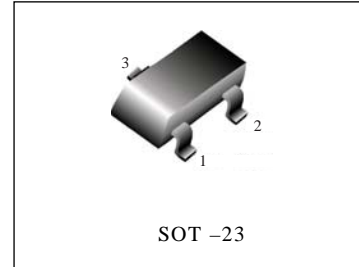

APPLICATIONS

- Ultra high-speed switching
- Voltage clamping
- Protection circuits.

DESCRIPTION

Planar Schottky barrier diodes with an integrated guard ring for stress protection. Single diodes and double diodes with different pinning are available.

We declare that the material of product compliance with RoHS requirements.

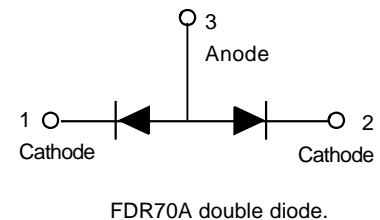
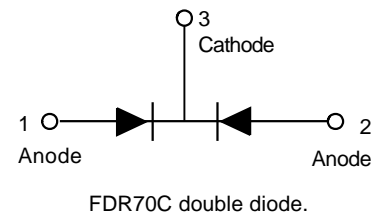
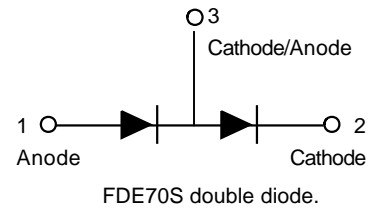

ORDERING INFORMATION

Device	Marking	Shipping
FDR70	BE	3000 Tape & Reel
FDR70S	74	3000 Tape & Reel
FDR70C	EH	3000 Tape & Reel
FDR70A	GK	3000 Tape & Reel

MAXIMUM RATINGS ($T_A = 25^\circ\text{C}$)

Parameter	Symbol	Min.	Max.	Unit	Conditions
Continuous reverse voltage	V_R	-	70	V	
Continuous forward current	I_F	-	70	mA	
Repetitive Peak forward surge current	I_{FSM}	-	70	mA	$t_p \leq 1\text{s}; \delta \leq 0.5$
Non-repetitive peak forward current	I_{FSM}	-	100	mA	$t_p < 10\text{ms}$
Storage temperature	T_{stg}	-65	+150	$^\circ\text{C}$	
Junction temperature	T_j	-	150	$^\circ\text{C}$	
Operating ambient temperature	T_{amb}	-65	+150	$^\circ\text{C}$	

DEVICE MARKING

FDR70 = BE FDR70S = CG FDR70C = EH FDR70A = GK

ELECTRICAL CHARACTERISTICS ($T_A = 25^\circ\text{C}$)

Parameter	Symbol	Max.	Unit	Conditions
Forward voltage(Fig.1)	V_F	410	mV	$I_F = 1\text{mA}$
		750	mv	$I_F = 10\text{mA}$
		1	v	$I_F = 15\text{mA}$
Reverse current(Fig.2 ;note1)	I_R	100	nA	$V_R = 50\text{V}$
		10	μA	$V_R = 70\text{V}$
Charge carrier life time (krakauer method)	τ	100	ps	$I_F = 5\text{mA}$
Diode capacitance(Fig.4)	C_d	2	pF	$f = 1\text{MHz}; V_R = 0$

Note:

1. Pulse test: $t_p = 300\mu\text{s}; \delta = 0.02$.

THERMAL CHARACTERISTICS

PARAMETER	SYMBOL	VALUE	UNIT	CONDITIONS
Thermal resistance from junction to ambient	$R_{th\ j-a}$	500	k/w	note1

Note

1. Refer to SOT23 or SOT143B standard mounting conditions.

Electrical characteristic curves ($T_A = 25^\circ\text{C}$)

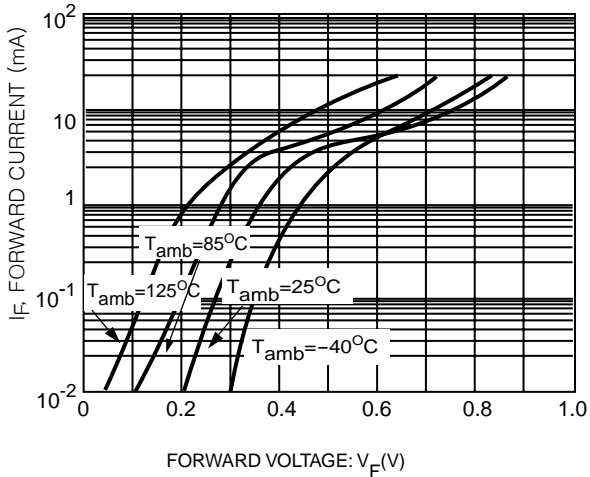

Fig.1 Forward current as a function of forward voltage; typical values.

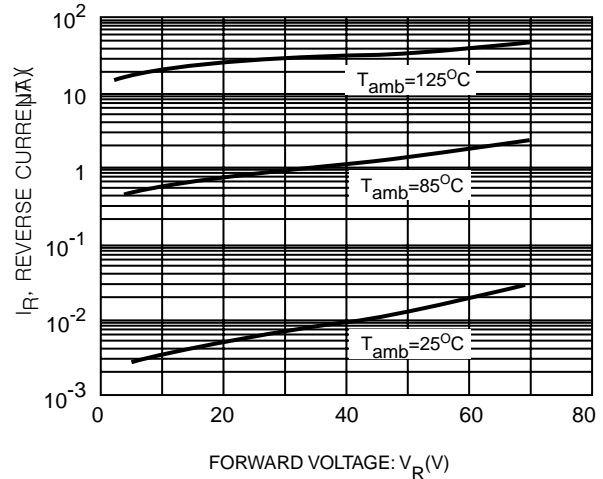

Fig.2 Reverse current as a function of reverse voltage; typical values.

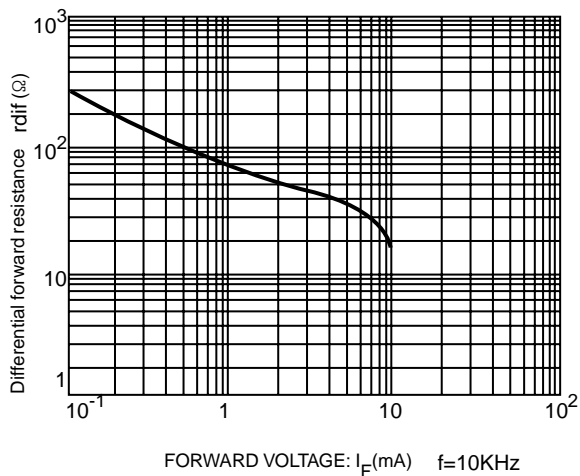

Fig.3 Differential forward resistance as a function of forward current; typical values.

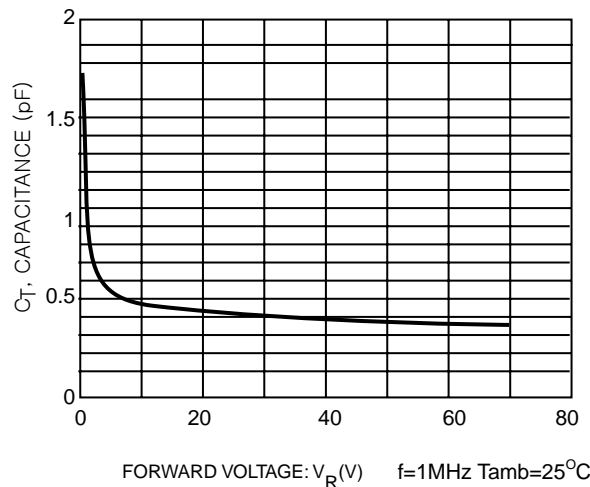
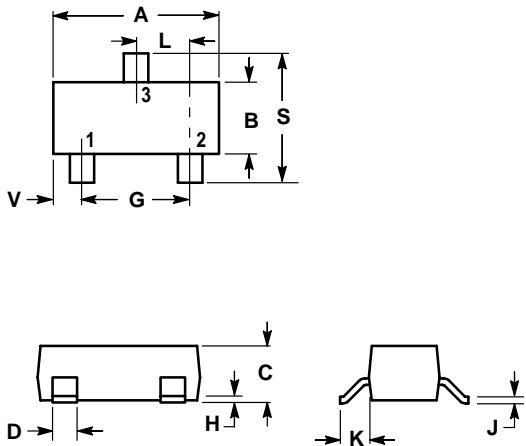

Fig.4 Diode capacitance as a function of reverse voltage; typical values.

SOT-23

NOTES:

1. DIMENSIONING AND TOLERANCING PER ANSI Y14.5M, 1982
2. CONTROLLING DIMENSION: INCH.



DIM	INCHES		MILLIMETERS	
	MIN	MAX	MIN	MAX
A	0.1102	0.1197	2.80	3.04
B	0.0472	0.0551	1.20	1.40
C	0.0350	0.0440	0.89	1.11
D	0.0150	0.0200	0.37	0.50
G	0.0701	0.0807	1.78	2.04
H	0.0005	0.0040	0.013	0.100
J	0.0034	0.0070	0.085	0.177
K	0.0140	0.0285	0.35	0.69
L	0.0350	0.0401	0.89	1.02
S	0.0830	0.1039	2.10	2.64
V	0.0177	0.0236	0.45	0.60

