

FEATURES

- Plastic package has Underwriters Laboratory Flammability Classification 94V-0
- Low forward voltage drop
- High current capability, High reliability
- Low power loss, high efficiency
- High surge current capability
- High speed switching, Low leakage
- High temperature soldering guaranteed: 260°C/10 seconds at terminals
- Component in accordance to RoHS 2011/65/EU

MECHANICAL DATA

- Case: JEDEC DO-15 molded plastic body
- Epoxy: UL94V-0 rate flame retardant
- Lead: Plated axial leads, solderable per MIL-STD-750, method 2026
- Polarity: Color band denotes cathode end
- Mounting Position: Any

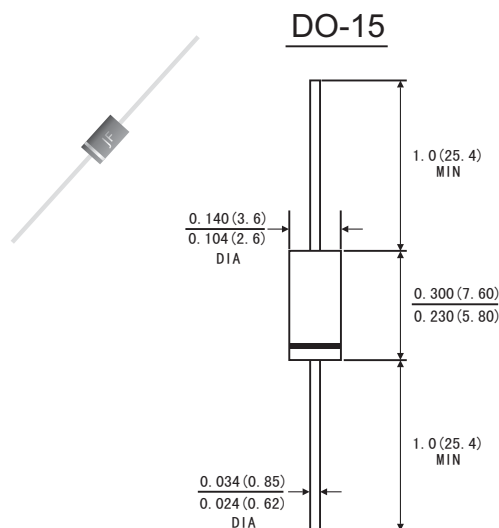

Dimensions in inches and (millimeters)

MAXIMUM RATINGS AND ELECTRICAL CHARACTERISTICS

(Rating at 25°C ambient temperature unless otherwise specified. Single phase, half wave, 60Hz, resistive or inductive load. For capacitive load, derate current by 20%.)

	Symbols	HER 201G	HER 202G	HER 203G	HER 204G	HER 205G	HER 206G	HER 207G	HER 208G	Units
Maximum Recurrent Peak Reverse Voltage	V _{RRM}	50	100	200	300	400	600	800	1000	Volts
Maximum RMS Voltage	V _{RMS}	35	70	140	210	280	420	560	700	Volts
Maximum DC Blocking Voltage	V _{DC}	50	100	200	300	400	600	800	1000	Volts
Maximum Average Forward Rectified Current 0.375"(9.5mm)lead length at T _A =55°C	I(AV)	2.0								Amps
Peak Forward Surge Current 8.3ms single half sine-wave superimposed on rated load (JEDEC method)	I _{FSM}	60.0								Amps
Maximum Instantaneous Forward Voltage at 2.0 A	V _F	1.0		1.3		1.7			Volts	
Maximum DC Reverse Current at rated DC blocking voltage	T _A =25°C	5.0								μA
	T _A =100°C	150								
Maximum reverse recovery time(Note1)	T _{rr}	50					75			ns
Typical junction capacitance(Note2)	C _J	50					30			pF
Operating junction and storage temperature range	T _J	-55 to +150								°C
	T _{STG}	-55 to +150								

Note: 1. Test conditions: I_F=0.5A, I_R=1.0A, I_{RR}=0.25A.

2. Measured at 1MHz and applied reverse voltage of 4.0 Volts.

RATINGS AND CHARACTERISTIC CURVES HER201G THRU HER208G

FIG.1-TEST CIRCUIT DIAGRAM AND REVERSE RECOVERY TIME CHARACTERISTIC

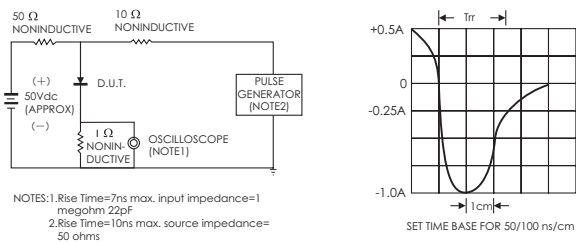

FIG.2-TYPICAL FORWARD CURRENT DERATING CURVE

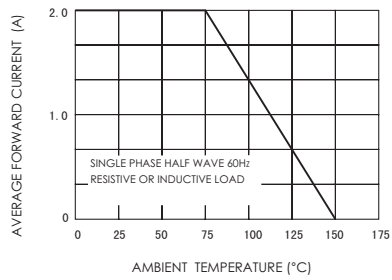

FIG.3-TYPICAL INSTANTANEOUS FORWARD CHARACTERISTICS

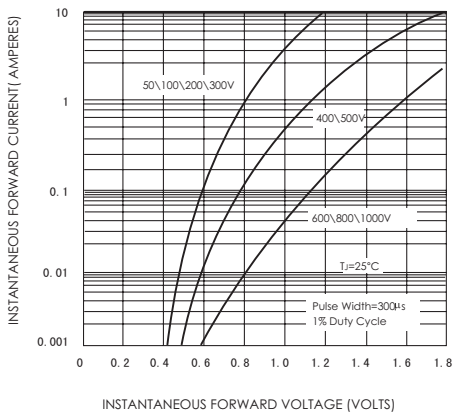

FIG.4-TYPICAL REVERSE CHARACTERISTICS

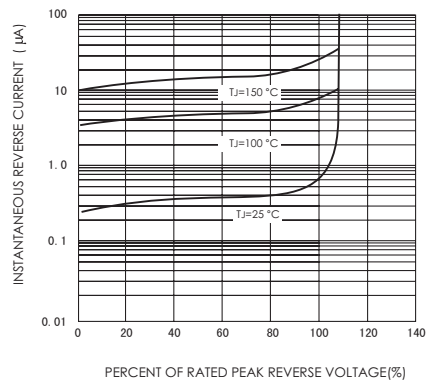

FIG.5-MAXIMUM NON-REPETITIVE FORWARD SURGE CURRENT

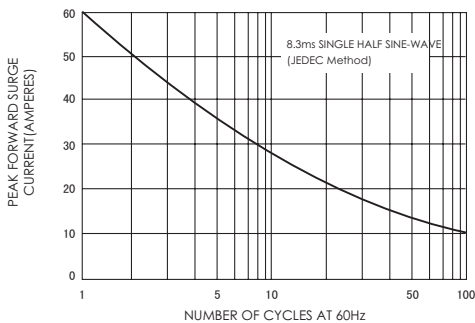

FIG.6-TYPICAL JUNCTION CAPACITANCE

