

Wall Industries, Inc.

LANCW15 SERIES

2:1 Wide Input Voltage Range
Single and Dual Outputs
24 Pin DIP Package
15 Watt DC/DC Power Converters



APPLICATIONS

- Wireless Networks
- Telecom / Datacom
- Measurement Equipment
- Industry Control Systems
- Semiconductor Equipment

FEATURES

- Single and Dual Outputs
- Low Profile
- High Power Density with 15 Watts Output Power
- 2:1 Wide Input Voltage Range
- High Efficiency up to 91%
- 1600VDC I/O Isolation
- Output Current up to 4A
- Positive Logic Remote ON/OFF
- Fixed Switching Frequency
- Over Voltage, Over Load, and Short Circuit Protection
- Low Standby Power Dissipation
- Input Under Voltage Lockout
- Six-Sided Continuous Shield
- Standard 24 Pin DIP Package
- UL60950-1, EN60950-1, and IEC60950-1 Safety Approvals
- Compliant to RoHS EU Directive 2002/95/EC

DESCRIPTION

The LANCW15 series of DC/DC power converters provides 15 watts of output power in a 1.25 x 0.80 x 0.40 inch DIP package. This series has single and dual output models with 2:1 wide input voltage ranges of 9-18VDC, 18-36VDC, and 36-75VDC. Some features include high efficiency, 1600VDC I/O isolation, six-sided shielding, and positive logic remote ON/OFF. These converters are also protected against over voltage (single outputs only), over load, and short circuit conditions. All models are RoHS compliant and have UL60950-1, EN60950-1, and IEC60950-1 safety approvals. This series is best suited for use in wireless networks, telecom/datacom, measurement equipment, industry control systems, and semiconductor equipment.

SPECIFICATIONS: LANCW15 Series						
All specifications are based on 25°C, Nominal Input Voltage, and Maximum Output Current unless otherwise noted. We reserve the right to change specifications based on technological advances.						
SPECIFICATION	TEST CONDITIONS		Min	Nom	Max	Unit
INPUT SPECIFICATIONS						
Input Voltage Range	12VDC nominal input models		9	12	18	VDC
	24VDC nominal input models		18	24	36	
	48VDC nominal input models		36	48	75	
Input Surge Voltage (1 sec max)	12VDC nominal input models				36	VDC
	24VDC nominal input models				50	
	48VDC nominal input models				100	
Start-Up Voltage	12VDC nominal input models				9	VDC
	24VDC nominal input models				18	
	48VDC nominal input models				36	
Shutdown Voltage	12VDC nominal input models			8		VDC
	24VDC nominal input models			16		
	48VDC nominal input models			33		
Input Reflected Ripple Current	Nominal Vin and full load			20		mAp-p
Input Filter			Pi type			
OUTPUT SPECIFICATIONS						
Output Voltage			See Table			
Line Regulation	Low line to high line at full load	Single Output	-0.2		+0.2	%
		Dual Output	-0.5		+0.5	
Load Regulation	No load to full load	Single Output	-0.5		+0.5	%
		Dual Output	-1		+1	
Cross Regulation (Dual Outputs)	Asymmetrical load 25% to 100% full load		-5		+5	%
Voltage Accuracy	Full load an nominal Vin		-1		+1	%
Output Power					15	W
Output Current			See Table			
Ripple & Noise (See Note 6)	20MHz Bandwidth			85		mVp-p
Transient Response Recovery Time	25% load step change			250		µs
Start-Up Time	Nominal Vin and constant resistive load	Power Up			30	ms
Minimum Load			0			%
Temperature Coefficient			-0.02		+0.02	%/°C
PROTECTION						
Over Load Protection	% of full load at nominal input			150		%
Short Circuit Protection			Hiccup, automatic recovery			
Over Voltage Protection (Single Outputs only)			See Table			
GENERAL SPECIFICATIONS						
Efficiency	Nominal Vin and full load		See Table			
Switching Frequency				330		KHz
Isolation Voltage	Input tot Output		1600			VDC
	Input to Case		1600			
	Output tot Case		1600			
Isolation Resistance			10			GΩ
Isolation Capacitance					2000	pF
REMOTE ON/OFF						
Positive Logic (See Note 7)	DC/DC ON		Open or 3.0V < Vr < 12V			
	DC/DC OFF		Short or 0V < Vr < 1.2V			
Input Current of Remote Control Pin	Nominal Vin		-0.5		+0.5	mA
Remote Off State Input Current	Nominal Vin			2.5		mA
ENVIRONMENTAL SPECIFICATIONS						
Operating Ambient Temperature	With derating		-40		+100	°C
Maximum Case Temperature					+105	°C
Storage Temperature			-55		+105	°C
Relative Humidity			5		95	% RH
Thermal Shock			MIL-STD-810F			
Vibration			MIL-STD-810F			
Thermal Impedance	Natural Convection			20		°C/Watt
MTBF (See Note 1)	BELLCORE TR-NWT-000332		3,378,000 hours			
	MIL-HDBK-217F		464,500 hours			
PHYSICAL SPECIFICATIONS						
Weight			0.51oz (14.4g)			
Case Material			Nickel-coated copper			
Base Material			FR4 PCB			
Potting Material			Epoxy (UL94-V0)			
Dimensions (L x W x H)			1.25 x 0.80 x 0.40 inches (31.8 x 20.3 x 10.2 mm)			
SAFETY & EMC CHARACTERISTICS						
Safety Approvals			IEC60950-1, UL60950-1, EN60950-1			
EMI (See Note 8)	EN55022		Class A			
	EN55022		Class B			
ESD	EN61000-4-2		Air	±8KV		Perf. Criteria A
			Contact	±6KV		
Radiated Immunity	EN61000-4-3		10 V/m		Perf. Criteria A	
Fast Transient (See Note 9)	EN61000-4-4		±2KV		Perf. Criteria A	
Surge (See Note 9)	EN61000-4-5		±1KV		Perf. Criteria A	
Conducted Immunity	EN61000-4-6		10 Vrms		Perf. Criteria A	

MODEL SELECTION TABLES

SINGLE OUTPUT MODELS										
Model Number	Input Voltage Range	Output Voltage	Output Current		Input Current		Over Voltage Protection	Output Power	Efficiency ⁽⁴⁾	Maximum ⁽⁵⁾ Capacitive Load
			Min. Load	Full Load	No Load ⁽³⁾	Full Load ⁽²⁾				
LANC1233W15	12 VDC (9 – 18 VDC)	3.3 VDC	0mA	4000mA	10mA	1325mA	3.9 VDC	13.2W	87%	4700µF
LANC1251W15		5.1 VDC	0mA	3000mA	10mA	1482mA	6.2 VDC	15W	90%	3300µF
LANC1212W15		12 VDC	0mA	1250mA	5mA	1453mA	15 VDC	15W	90%	600µF
LANC1215W15		15 VDC	0mA	1000mA	10mA	1453mA	18 VDC	15W	90%	400µF
LANC2433W15	24 VDC (18 – 36 VDC)	3.3 VDC	0mA	4000mA	6mA	654mA	3.9 VDC	13.2W	88%	4700µF
LANC2451W15		5.1 VDC	0mA	3000mA	6mA	741mA	6.2 VDC	15W	90%	3300µF
LANC2412W15		12 VDC	0mA	1250mA	4mA	718mA	15 VDC	15W	91%	600µF
LANC2415W15		15 VDC	0mA	1000mA	6mA	718mA	18 VDC	15W	91%	400µF
LANC4833W15	48 VDC (36 – 75 VDC)	3.3 VDC	0mA	4000mA	4mA	327mA	3.9 VDC	13.2W	88%	4700µF
LANC4851W15		5.1 VDC	0mA	3000mA	4mA	371mA	6.2 VDC	15W	90%	3300µF
LANC4812W15		12 VDC	0mA	1250mA	4mA	363mA	15 VDC	15W	90%	600µF
LANC4815W15		15 VDC	0mA	1000mA	4mA	359mA	18 VDC	15W	91%	400µF

DUAL OUTPUT MODELS										
Model Number	Input Voltage Range	Output Voltage	Output Current		Input Current		Output ⁽⁶⁾ Ripple & Noise	Output Power	Efficiency ⁽⁴⁾	Maximum ⁽⁵⁾ Capacitive Load
			Min. Load	Full Load	No Load ⁽³⁾	Full Load ⁽²⁾				
LANC1205DW15	12 VDC (9 – 18 VDC)	±5 VDC	0mA	±1500mA	10mA	1524mA	85mVp-p	15W	86%	±1500µF
LANC1212DW15		±12 VDC	0mA	±625mA	6mA	1453mA	85mVp-p	15W	90%	±288µF
LANC1215DW15		±15 VDC	0mA	±500mA	10mA	1453mA	85mVp-p	15W	90%	±200µF
LANC2405DW15	24 VDC (18 – 36 VDC)	±5 VDC	0mA	±1500mA	4mA	753mA	85mVp-p	15W	87%	±1500µF
LANC2412DW15		±12 VDC	0mA	±625mA	6mA	726mA	85mVp-p	15W	90%	±288µF
LANC2415DW15		±15 VDC	0mA	±500mA	6mA	727mA	85mVp-p	15W	90%	±200µF
LANC4805DW15	48 VDC (36 – 75 VDC)	±5 VDC	0mA	±1500mA	4mA	376mA	85mVp-p	15W	87%	±1500µF
LANC4812DW15		±12 VDC	0mA	±625mA	4mA	363mA	85mVp-p	15W	90%	±288µF
LANC4815DW15		±15 VDC	0mA	±500mA	4mA	363mA	85mVp-p	15W	90%	±200µF

NOTES

- BELLCORE TR-NWT-000332. Case 1: 50% Stress, Temperature at 40°C. MIL-HDBK-217F Notice2 @Ta=25°C, Full load (Ground, Benign, controlled environment).
 - Maximum value at nominal input voltage and full load.
 - Typical value at nominal input voltage and no load.
 - Typical value at nominal input voltage and full load.
 - Test by minimum Vin and constant resistive load.
 - Ripple and Noise is measured with a 1µF ceramic capacitor in parallel with the output pins.
 - The ON/OFF control pin voltage is referenced to -Vin.
 - The LANCW15 series can meet EN55022 Class B with an external filter on the input pins to the converter. The filter capacitor suggested is TBD.
 - An external input filter capacitor is required if the module has to meet EN61000-4-4, EN61000-4-5. The filter capacitor suggested is TBD.
- Due to advances in technology, specifications subject to change without notice.*

DERATING CURVE

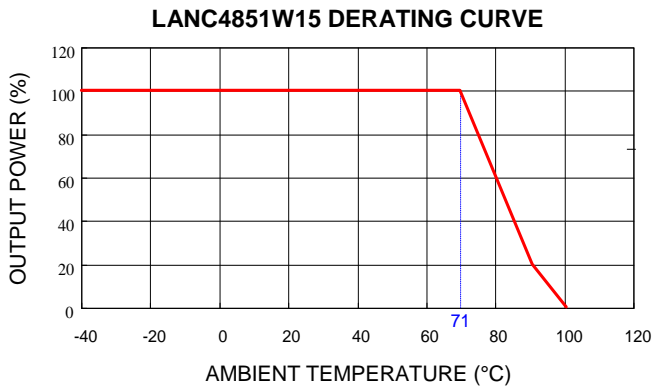

CHARACTERISTICS

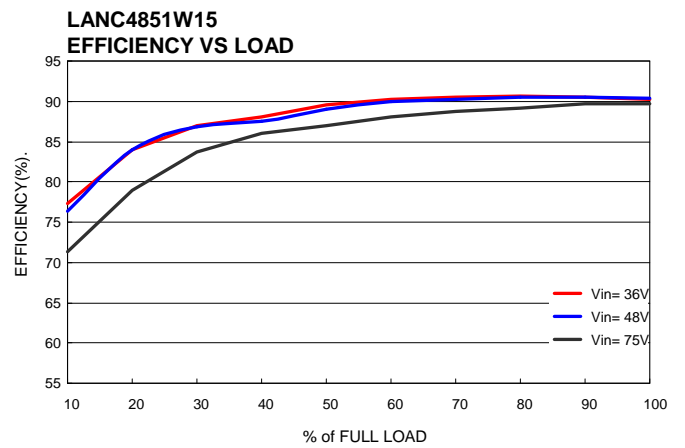
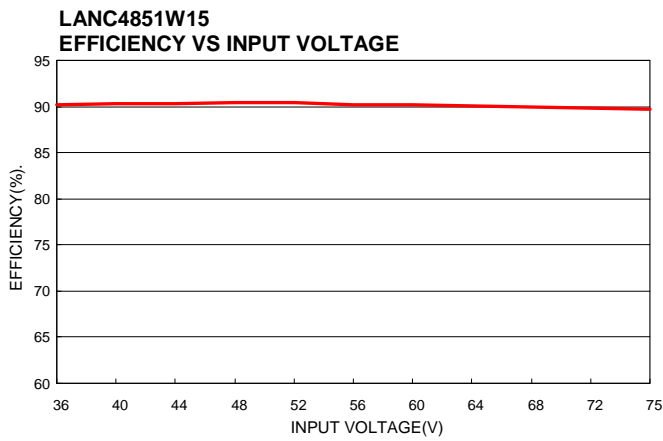

Recommended Filter for EN55022 Class B Compliance

Recommended EN55022 Class B Filter Circuit Layout

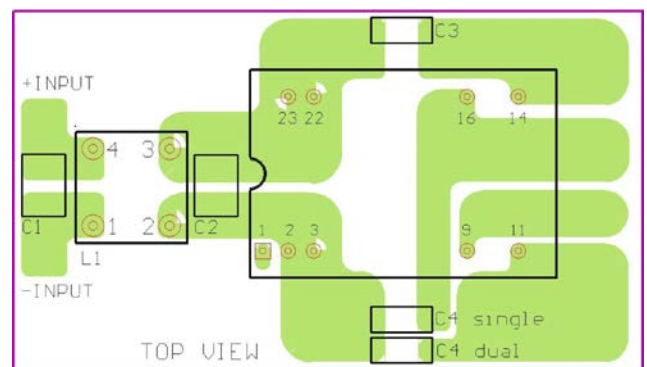
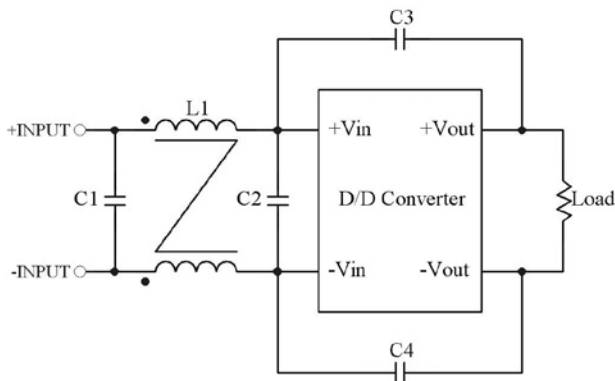

The components used in the figure above are as follows: TBD

	C1	C2	C3	C4	L1
LANC12xxW15	TBD	TBD	TBD	TBD	TBD
LANC24xxW15	TBD	TBD	TBD	TBD	TBD
LANC48xxW15	TBD	TBD	TBD	TBD	TBD

MECHANICAL DRAWING

Unit: inches (mm)

Pin size is 0.02(0.5) Dia

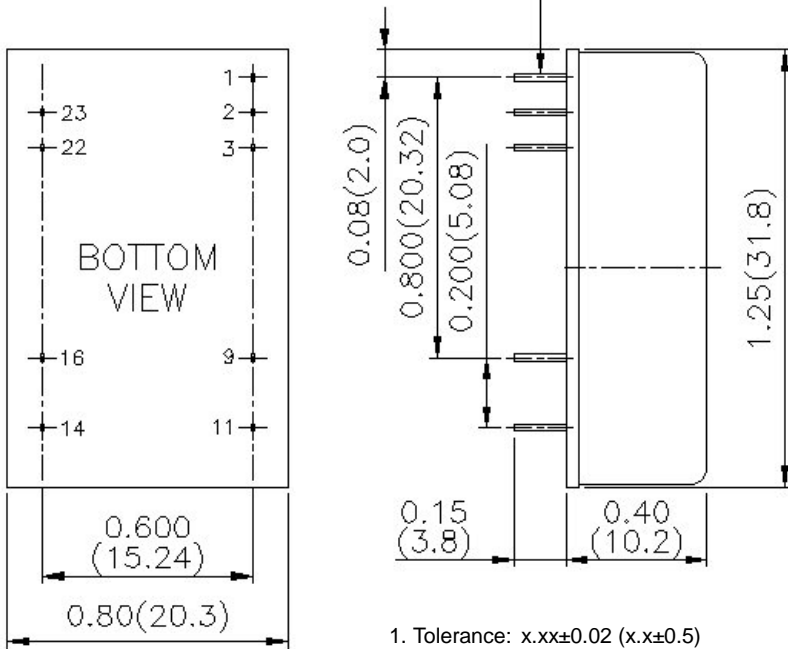

1. Tolerance: x.xx±0.02 (x.x±0.5)
 x.xxx±0.01 (x.xx±0.25)
2. Pin Pitch Tolerance: ±0.01 (0.25)

PIN CONNECTIONS					
PIN	SINGLE	DUAL	PIN	SINGLE	DUAL
1	CTRL	CTRL			
2	-INPUT	-INPUT	23	+INPUT	+INPUT
3	-INPUT	-INPUT	22	+INPUT	+INPUT
9	NC	COMMON	16	-OUTPUT	COMMON
11	NC	-OUTPUT	14	+OUTPUT	+OUTPUT

COMPANY INFORMATION

Wall Industries, Inc. has created custom and modified units for over 50 years. Our in-house research and development engineers will provide a solution that exceeds your performance requirements on-time and on budget. Our ISO9001-2008 certification is just one example of our commitment to producing a high quality, well-documented product for our customers.

Our past projects demonstrate our commitment to you, our customer. Wall Industries, Inc. has a reputation for working closely with its customers to ensure each solution meets or exceeds form, fit and function requirements. We will continue to provide ongoing support for your project above and beyond the design and production phases. Give us a call today to discuss your future projects.

Contact **Wall Industries** for further information:

Phone: ☎ (603)778-2300
Toll Free: ☎ (888)587-9255
Fax: ☎ (603)778-9797
E-mail: sales@wallindustries.com
Web: www.wallindustries.com
Address: 5 Watson Brook Rd.
 Exeter, NH 03833