

SERIAL ACCESS RTC WITH ALARMS

FEATURES SUMMARY

- 2.0 TO 5.5V CLOCK OPERATING VOLTAGE
- COUNTERS FOR TENTHS/HUNDREDTHS OF SECONDS, SECONDS, MINUTES, HOURS, DAY, DATE, MONTH, YEAR, and CENTURY
- AUTOMATIC SWITCH-OVER and DESELECT CIRCUITRY
- SERIAL INTERFACE SUPPORTS I²C BUS (400KHz PROTOCOL)
- PROGRAMMABLE ALARM and INTERRUPT FUNCTION (valid even during Battery Back-up Mode)
- WATCHDOG TIMER
- LOW OPERATING CURRENT OF 400 μ A
- BATTERY BACK-UP NOT RECOMMENDED FOR 3.0V APPLICATIONS (CAPACITOR BACK-UP ONLY)
- BATTERY OR SUPER-CAP BACK-UP
- OPERATING TEMPERATURE OF -40 TO 85°C
- ULTRA-LOW BATTERY SUPPLY CURRENT OF 1 μ A
- PACKAGE OPTIONS INCLUDE A 28-LEAD or 18-LEAD EMBEDDED CRYSTAL SOIC

Figure 1. 8-pin SOIC Package

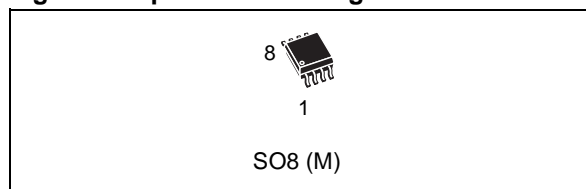

Figure 2. 28-pin (300mil) SOIC Package*

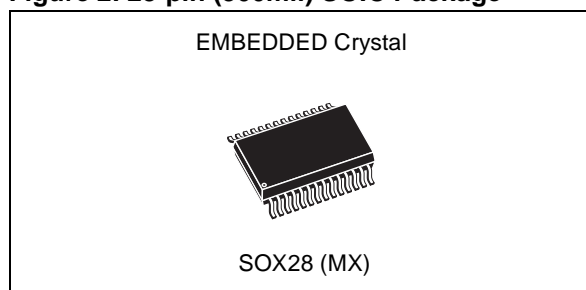

Figure 3. 18-pin (300mil) SOIC Package*

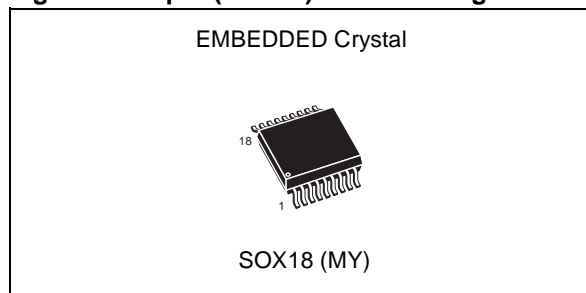

TABLE OF CONTENTS

SUMMARY DESCRIPTION	4
Figure 4. Logic Diagram	4
Table 1. Signal Names	4
Figure 5. 8-pin SOIC (M) Connections	5
Figure 7. 28-pin, 300mil SOIC (MX) Connections	5
Figure 6. 18-pin, 300mil SOIC (MY) Connections	5
Figure 8. Block Diagram	5
MAXIMUM RATING	6
Table 2. Absolute Maximum Ratings	6
DC AND AC PARAMETERS	7
Table 3. Operating and AC Measurement Conditions	7
Figure 9. AC Measurement I/O Waveform	7
Table 4. Capacitance	7
Table 5. DC Characteristics	8
Table 6. Crystal Electrical Characteristics	8
OPERATION	9
2-Wire Bus Characteristics	9
Figure 10. Serial Bus Data Transfer Sequence	10
Figure 11. Acknowledgement Sequence	10
Figure 12. Bus Timing Requirements Sequence	11
Table 7. AC Characteristics	11
READ Mode	12
Figure 13. Slave Address Location	12
Figure 14. READ Mode Sequence	12
Figure 15. Alternative READ Mode Sequence	13
WRITE Mode	13
Figure 16. WRITE Mode Sequence	13
Data Retention Mode	14
Figure 17. Power Down/Up Mode AC Waveforms	14
Table 8. Power Down/Up AC Characteristics	14
Table 9. Power Down/Up Trip Points DC Characteristics	14
CLOCK OPERATION	15
TIMEKEEPER® Registers	15
Table 10. TIMEKEEPER® Register Map	16
Calibrating the Clock	17
Setting Alarm Clock Registers	18
Figure 18. Alarm Interrupt Reset Waveform	18

Figure 19. Back-up Mode Alarm Waveform	18
Table 11. Alarm Repeat Modes	19
Watchdog Timer	19
Square Wave Output	20
Table 12. Square Wave Output Frequency	20
Century Bit	21
Output Driver Pin	21
Preferred Initial Power-on Default	21
Table 13. Preferred Default Values	21
Figure 20. Crystal Accuracy Across Temperature	22
Figure 21. Clock Calibration	22
PACKAGE MECHANICAL INFORMATION	23
PART NUMBERING	26
REVISION HISTORY	27

SUMMARY DESCRIPTION

The M41T81 Serial Access TIMEKEEPER® SRAM is a low power Serial RTC with a built-in 32.768 KHz oscillator (external crystal controlled). Eight bytes of the SRAM (see Table 10, page 16) are used for the clock/calendar function and are configured in binary coded decimal (BCD) format. An additional 12 bytes of SRAM provide status/control of Alarm, Watchdog and Square Wave functions. Addresses and data are transferred serially via a two line, bi-directional I²C interface. The built-in address register is incremented automatically after each WRITE or READ data byte.

The M41T81 has a built-in power sense circuit which detects power failures and automatically switches to the battery supply when a power failure occurs. The energy needed to sustain the SRAM and clock operations can be supplied by a

small lithium button supply when a power failure occurs. Functions available to the user include a non-volatile, time-of-day clock/calendar, Alarm interrupts, Watchdog Timer and programmable Square Wave output. The eight clock address locations contain the century, year, month, date, day, hour, minute, second and tenths/hundredths of a second in 24 hour BCD format. Corrections for 28, 29 (leap year - valid until year 2100), 30 and 31 day months are made automatically.

The M41T81 is supplied in either an 8-pin SOIC or an 18-pin (MY) or 28-pin (MX), 300mil SOIC package which includes an embedded 32kHz crystal.

The 8-pin and 28-pin, embedded crystal SOIC requires only a user-supplied battery to provide non-volatile operation.

Figure 4. Logic Diagram

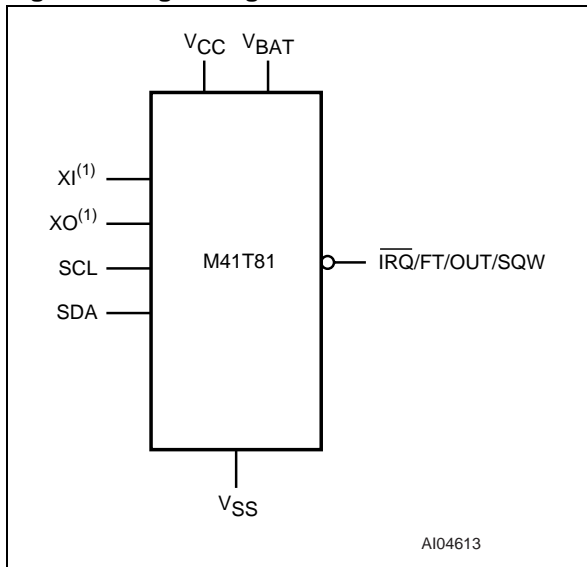

Note: 1. For SO8 package only.

Table 1. Signal Names

XI ⁽¹⁾	Oscillator Input
XO ⁽¹⁾	Oscillator Output
$\overline{\text{IRQ/OUT/FT/SQW}}$	Interrupt / Output Driver / Frequency Test / Square Wave (Open Drain)
SDA	Serial Data Input/Output
SCL	Serial Clock Input
V _{BAT}	Battery Supply Voltage
V _{CC}	Supply Voltage
V _{SS}	Ground

Note: 1. For SO8 package only.

Figure 5. 8-pin SOIC (M) Connections

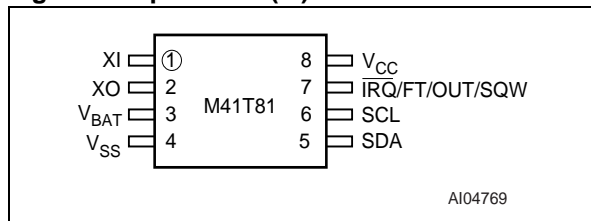

Figure 6. 18-pin, 300mil SOIC (MY) Connections

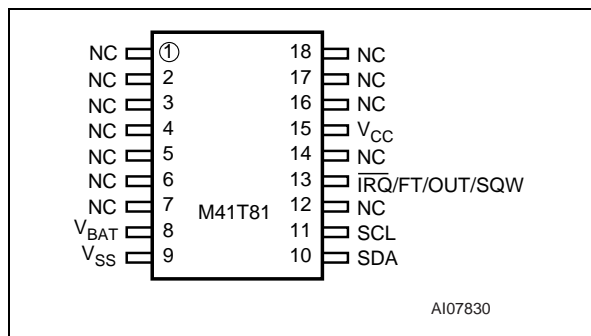
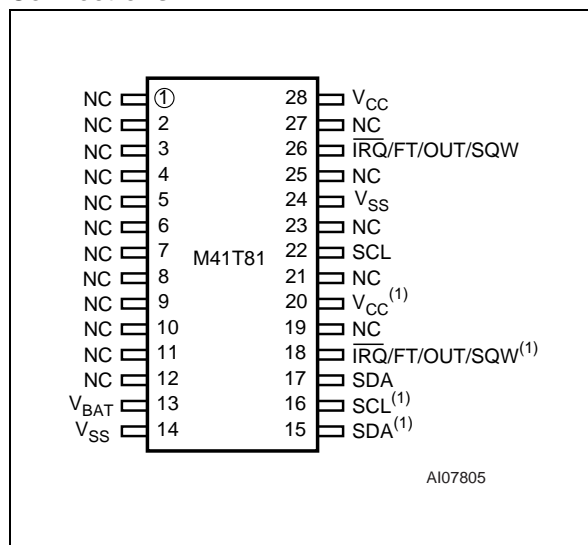
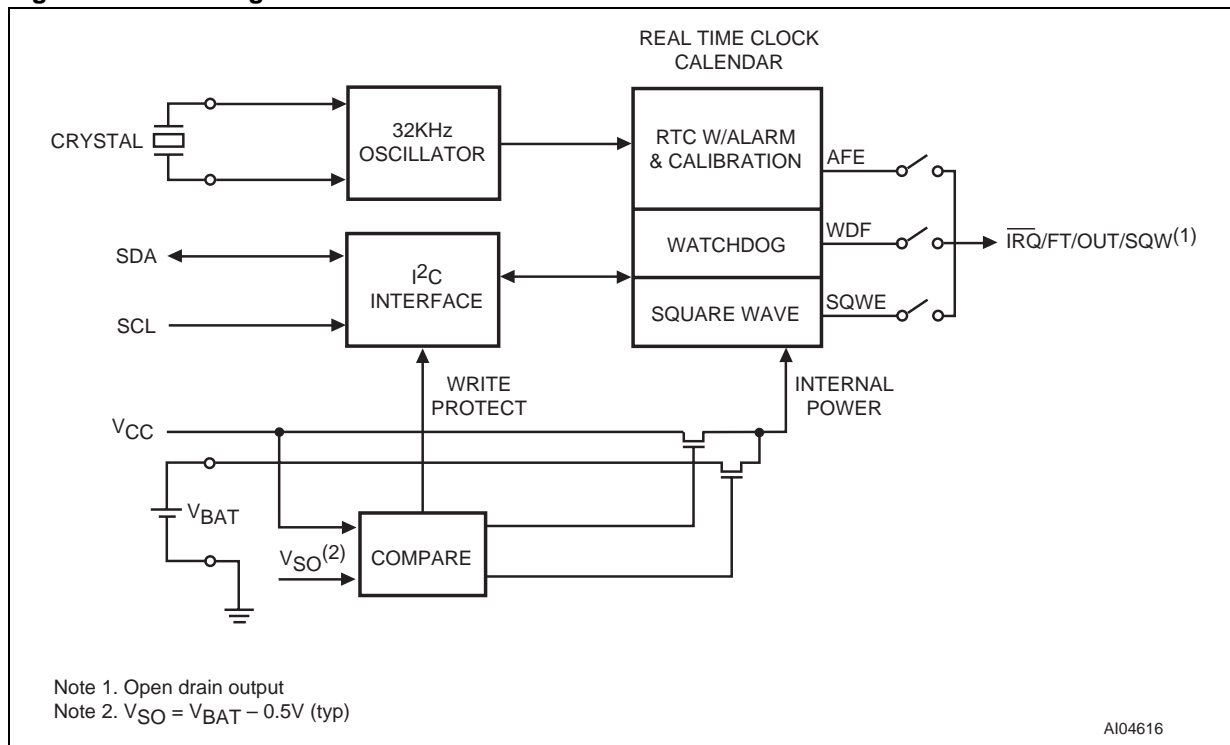

Figure 7. 28-pin, 300mil SOIC (MX) Connections



Note: 1. No Connect (NC) pin for 28-pin SOIC, but should be considered to have indicated function in anticipation of replacement with 18-pin SOIC.

Figure 8. Block Diagram



MAXIMUM RATING

Stressing the device above the rating listed in the “Absolute Maximum Ratings” table may cause permanent damage to the device. These are stress ratings only and operation of the device at these or any other conditions above those indicated in the Operating sections of this specification is

not implied. Exposure to Absolute Maximum Rating conditions for extended periods may affect device reliability. Refer also to the STMicroelectronics SURE Program and other relevant quality documents.

Table 2. Absolute Maximum Ratings

Sym	Parameter		Value	Unit
T _{STG}	Storage Temperature (V _{CC} Off, Oscillator Off)	SOIC	–55 to 125	°C
V _{CC}	Supply Voltage		–0.3 to 7	V
T _{SLD} ⁽¹⁾	Lead Solder Temperature for 10 Seconds		260	°C
V _{IO}	Input or Output Voltages		–0.3 to V _{CC} +0.3	V
I _O	Output Current		20	mA
P _D	Power Dissipation		1	W

Note: 1. Reflow at peak temperature of 215°C to 225°C for < 60 seconds (total thermal budget not to exceed 180°C for between 90 to 120 seconds).

CAUTION: Negative undershoots below –0.3 volts are not allowed on any pin while in the Battery Back-Up Mode

DC AND AC PARAMETERS

This section summarizes the operating and measurement conditions, as well as the DC and AC characteristics of the device. The parameters in the following DC and AC Characteristic tables are derived from tests performed under the Measure-

ment Conditions listed in the relevant tables. Designers should check that the operating conditions in their projects match the measurement conditions when using the quoted parameters.

Table 3. Operating and AC Measurement Conditions

Parameter	M41T81
Supply Voltage (V_{CC})	2.0 to 5.5V
Ambient Operating Temperature (T_A)	-40 to 85°C
Load Capacitance (C_L)	100pF
Input Rise and Fall Times	≤ 50 ns
Input Pulse Voltages	$0.2V_{CC}$ to $0.8V_{CC}$
Input and Output Timing Ref. Voltages	$0.3V_{CC}$ to $0.7V_{CC}$

Note: Output Hi-Z is defined as the point where data is no longer driven.

Figure 9. AC Measurement I/O Waveform

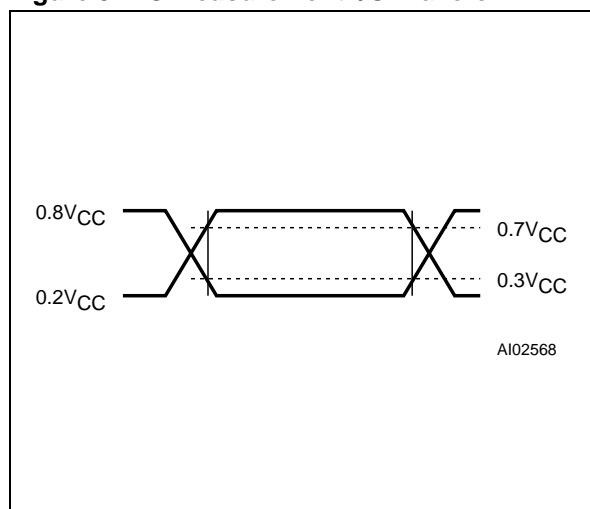

Table 4. Capacitance

Symbol	Parameter ^(1,2)	Min	Max	Unit
C_{IN}	Input Capacitance		7	pF
$C_{OUT}^{(3)}$	Output Capacitance		10	pF
t_{LP}	Low-pass filter input time constant (SDA and SCL)		50	ns

Note: 1. Effective capacitance measured with power supply at 5V; sampled only, not 100% tested.
 2. At 25°C, $f = 1$ MHz.
 3. Outputs deselected.

Table 5. DC Characteristics

Sym	Parameter	Test Condition ⁽¹⁾	Min	Typ	Max	Unit
I _{LI}	Input Leakage Current	$0V \leq V_{IN} \leq V_{CC}$			±1	μA
I _{LO}	Output Leakage Current	$0V \leq V_{OUT} \leq V_{CC}$			±1	μA
I _{CC1}	Supply Current	Switch Freq = 400kHz			400	μA
I _{CC2}	Supply Current (standby)	SCL, SDA = V _{CC} - 0.3V			100	μA
V _{IL}	Input Low Voltage		-0.3		0.3V _{CC}	V
V _{IH}	Input High Voltage		0.7V _{CC}		V _{CC} + 0.3	V
V _{OL}	Output Low Voltage	I _{OL} = 3.0mA			0.4	V
	Output Low Voltage (Open Drain) ⁽⁵⁾	I _{OL} = 10mA			0.4	V
V _{BAT} ⁽²⁾	Battery Supply Voltage		2.5 ⁽³⁾	3	3.5 ⁽⁴⁾	V
I _{BAT}	Battery Supply Current	T _A = 25°C, V _{CC} = 0V Oscillator ON, V _{BAT} = 3V		0.6	1	μA

- Note: 1. Valid for Ambient Operating Temperature: T_A = -40 to 85°C; V_{CC} = 2.0 to 5.5V (except where noted).
2. STMicroelectronics recommends the RAYOVAC BR1225 or BR1632 (or equivalent) as the battery supply.
3. After switchover (V_{SO}), V_{BAT} (min) can be 2.0V for crystal with R_S = 40kΩ.
4. For rechargeable back-up, V_{BAT} (max) may be considered V_{CC}.
5. For IRQ/FT/OUT/SQW pin (Open Drain)

Table 6. Crystal Electrical Characteristics

Sym	Parameter ^(1,2,3)	Min	Typ	Max	Units
f _O	Resonant Frequency		32.768		kHz
R _S	Series Resistance			60	kΩ
C _L	Load Capacitance		12.5		pF

- Note: 1. Externally supplied if using the SO8 package. STMicroelectronics recommends the KDS DT-38: 1TA/1TC252E127, Tuning Fork Type (thru-hole) or the DMX-26S: 1TJS125FH2A212, (SMD) quartz crystal for industrial temperature operations. KDS can be contacted at kouhou@kdsj.co.jp or http://www.kdsj.co.jp for further information on this crystal type.
2. Load capacitors are integrated within the M41T81. Circuit board layout considerations for the 32.768 kHz crystal of minimum trace lengths and isolation from RF generating signals should be taken into account.

OPERATION

The M41T81 clock operates as a slave device on the serial bus. Access is obtained by implementing a start condition followed by the correct slave address (D0h). The 20 bytes contained in the device can then be accessed sequentially in the following order:

1. Tenths/Hundredths of a Second Register
2. Seconds Register
3. Minutes Register
4. Century/Hours Register
5. Day Register
6. Date Register
7. Month Register
8. Year Register
9. Control Register
10. Watchdog Register
- 11 - 16. Alarm Registers
- 17 - 19. Reserved
20. Square Wave Register

The M41T81 clock continually monitors V_{CC} for an out-of-tolerance condition. Should V_{CC} fall below V_{SO} , the device terminates an access in progress and resets the device address counter. Inputs to the device will not be recognized at this time to prevent erroneous data from being written to the device from an out-of-tolerance system. The device also automatically switches over to the battery and powers down into an ultra low current mode of operation to conserve battery life. As system power returns and V_{CC} rises above V_{SO} , the battery is disconnected, and the power supply is switched to external V_{CC} .

For more information on Battery Storage Life refer to Application Note AN1012.

2-Wire Bus Characteristics

The bus is intended for communication between different ICs. It consists of two lines: a bi-directional data signal (SDA) and a clock signal (SCL). Both the SDA and SCL lines must be connected to a positive supply voltage via a pull-up resistor.

The following protocol has been defined:

- Data transfer may be initiated only when the bus is not busy.
- During data transfer, the data line must remain stable whenever the clock line is High.

- Changes in the data line, while the clock line is High, will be interpreted as control signals.

Accordingly, the following bus conditions have been defined:

Bus not busy. Both data and clock lines remain High.

Start data transfer. A change in the state of the data line, from high to Low, while the clock is High, defines the START condition.

Stop data transfer. A change in the state of the data line, from Low to High, while the clock is High, defines the STOP condition.

Data Valid. The state of the data line represents valid data when after a start condition, the data line is stable for the duration of the high period of the clock signal. The data on the line may be changed during the Low period of the clock signal. There is one clock pulse per bit of data.

Each data transfer is initiated with a start condition and terminated with a stop condition. The number of data bytes transferred between the start and stop conditions is not limited. The information is transmitted byte-wide and each receiver acknowledges with a ninth bit.

By definition a device that gives out a message is called "transmitter," the receiving device that gets the message is called "receiver." The device that controls the message is called "master." The devices that are controlled by the master are called "slaves."

Acknowledge. Each byte of eight bits is followed by one Acknowledge Bit. This Acknowledge Bit is a low level put on the bus by the receiver whereas the master generates an extra acknowledge related clock pulse. A slave receiver which is addressed is obliged to generate an acknowledge after the reception of each byte that has been clocked out of the slave transmitter.

The device that acknowledges has to pull down the SDA line during the acknowledge clock pulse in such a way that the SDA line is a stable Low during the High period of the acknowledge related clock pulse. Of course, setup and hold times must be taken into account. A master receiver must signal an end of data to the slave transmitter by not generating an acknowledge on the last byte that has been clocked out of the slave. In this case the transmitter must leave the data line High to enable the master to generate the STOP condition.

Figure 10. Serial Bus Data Transfer Sequence

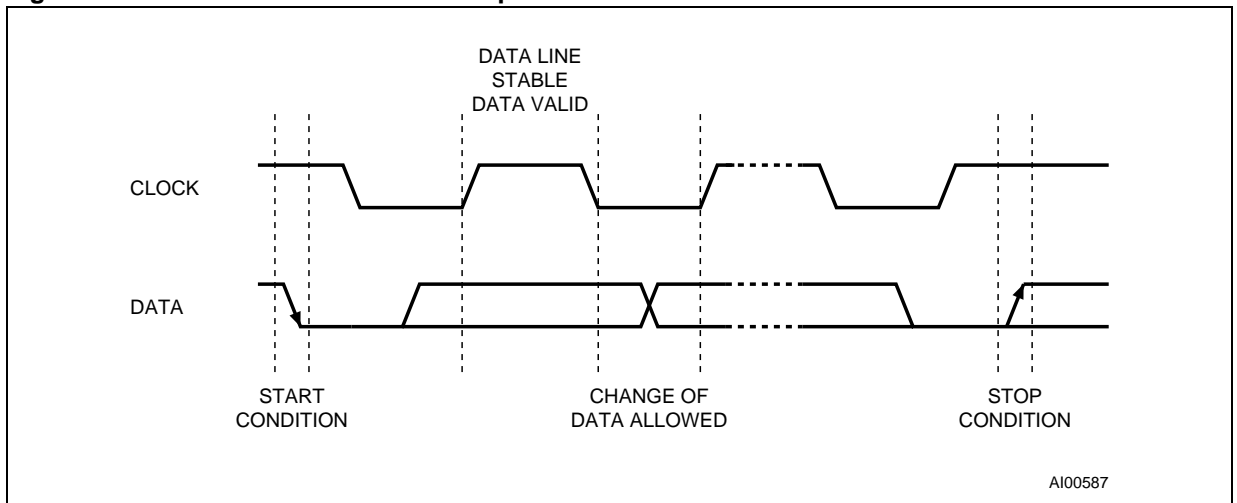

Figure 11. Acknowledgement Sequence

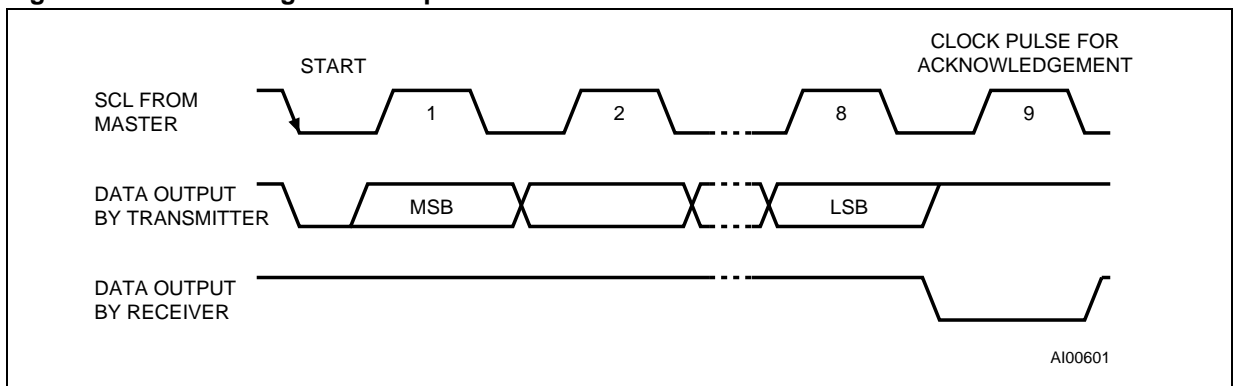

Figure 12. Bus Timing Requirements Sequence

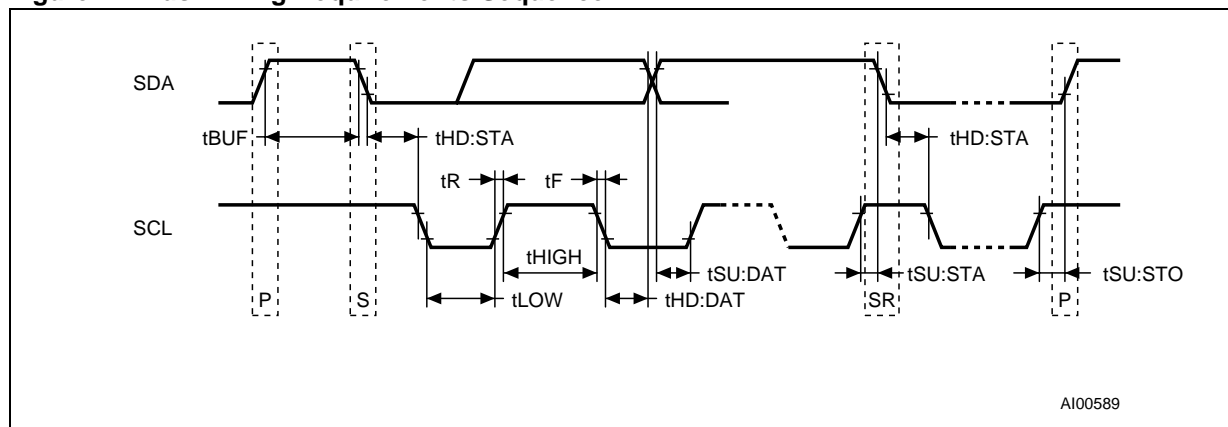

Table 7. AC Characteristics

Sym	Parameter ⁽¹⁾	Min	Typ	Max	Units
f_{SCL}	SCL Clock Frequency	0		400	kHz
t_{LOW}	Clock Low Period	1.3			μ s
t_{HIGH}	Clock High Period	600			ns
t_R	SDA and SCL Rise Time			300	ns
t_F	SDA and SCL Fall Time			300	ns
$t_{HD:STA}$	START Condition Hold Time (after this period the first clock pulse is generated)	600			ns
$t_{SU:STA}$	START Condition Setup Time (only relevant for a repeated start condition)	600			ns
$t_{SU:DAT}^{(2)}$	Data Setup Time	100			ns
$t_{HD:DAT}$	Data Hold Time	0			μ s
$t_{SU:STO}$	STOP Condition Setup Time	600			ns
t_{BUF}	Time the bus must be free before a new transmission can start	1.3			μ s

Note: 1. Valid for Ambient Operating Temperature: $T_A = -40$ to 85°C ; $V_{CC} = 2.0$ to 5.5V (except where noted).

2. Transmitter must internally provide a hold time to bridge the undefined region (300ns max) of the falling edge of SCL.

READ Mode

In this mode the master reads the M41T81 slave after setting the slave address (see Figure 14, page 12). Following the WRITE Mode Control Bit (R/W=0) and the Acknowledge Bit, the word address 'An' is written to the on-chip address pointer. Next the START condition and slave address are repeated followed by the READ Mode Control Bit (R/W=1). At this point the master transmitter becomes the master receiver. The data byte which was addressed will be transmitted and the master receiver will send an Acknowledge Bit to the slave transmitter. The address pointer is only incremented on reception of an Acknowledge Clock. The M41T81 slave transmitter will now place the data byte at address An+1 on the bus, the master receiver reads and acknowledges the new byte and the address pointer is incremented to "An+2."

This cycle of reading consecutive addresses will continue until the master receiver sends a STOP condition to the slave transmitter.

The system-to-user transfer of clock data will be halted whenever the address being read is a clock address (00h to 07h). The update will resume due to a Stop Condition or when the pointer increments to any non-clock address (08h-13h).

Note: This is true both in READ Mode and WRITE Mode.

An alternate READ Mode may also be implemented whereby the master reads the M41T81 slave without first writing to the (volatile) address pointer. The first address that is read is the last one stored in the pointer (see Figure 15, page 13).

Figure 13. Slave Address Location

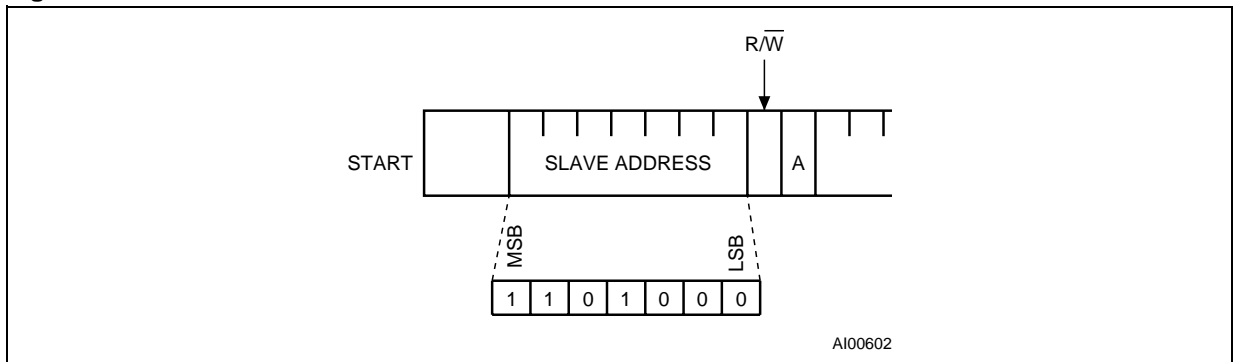

Figure 14. READ Mode Sequence

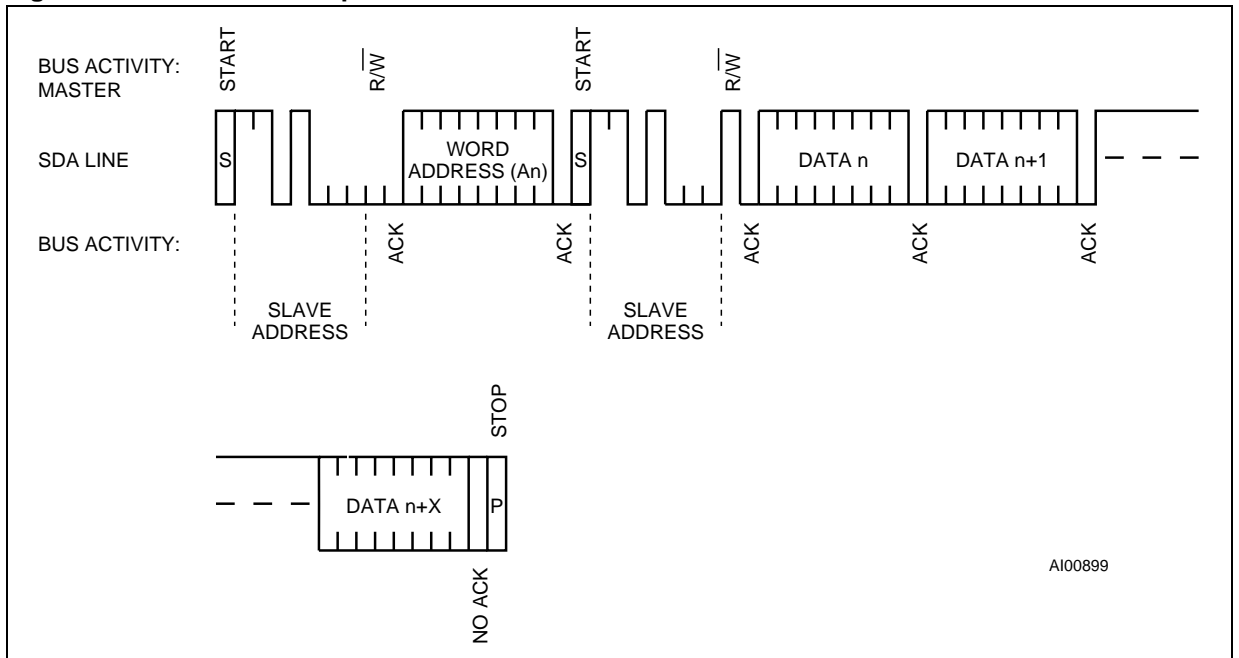
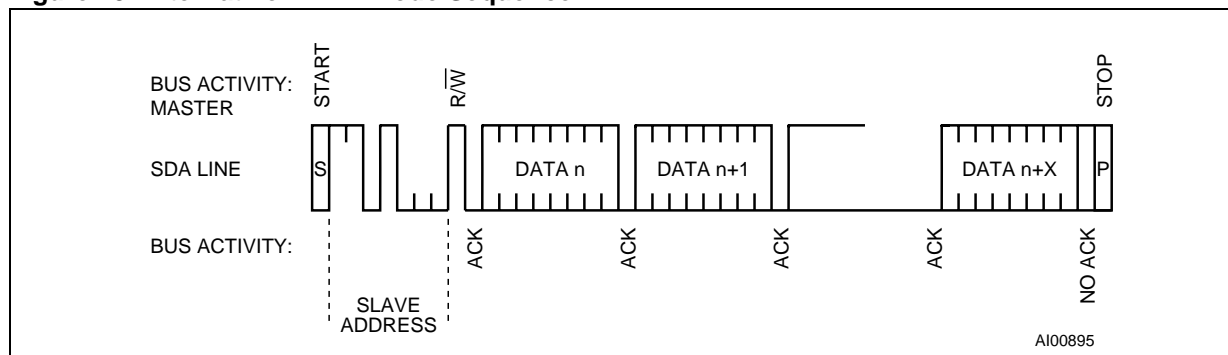

Figure 15. Alternative READ Mode Sequence



WRITE Mode

In this mode the master transmitter transmits to the M41T81 slave receiver. Bus protocol is shown in Figure 16, page 13. Following the START condition and slave address, a logic '0' (R/W=0) is placed on the bus and indicates to the addressed device that word address "An" will follow and is to be written to the on-chip address pointer. The data word to be written to the memory is strobed in next

and the internal address pointer is incremented to the next address location on the reception of an acknowledge clock. The M41T81 slave receiver will send an acknowledge clock to the master transmitter after it has received the slave address see Figure 13, page 12 and again after it has received the word address and each data byte.

Figure 16. WRITE Mode Sequence

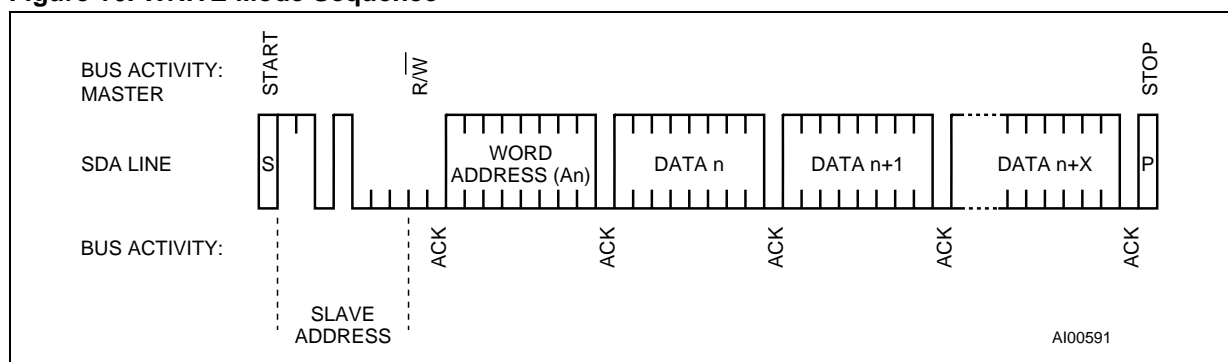

Data Retention Mode

With valid V_{CC} applied, the M41T81 can be accessed as described above with READ or WRITE Cycles. Should the supply voltage decay, the power input will be switched from the V_{CC} pin to the battery when V_{CC} falls below the Battery Back-up Switchover Voltage (V_{SO}). At this time the clock registers will be maintained by the attached battery supply. As V_{CC} continues to fall, the M41T81

will pass through the Register Bit Reset Voltage (V_{RST}) threshold, not only write protecting itself, but also resetting certain Control Bits (see Table 13, page 21). On power-up, when V_{CC} returns to a nominal value, write protection continues for t_{REC} . For a further, more detailed review of lifetime calculations, please see Application Note AN1012.

Figure 17. Power Down/Up Mode AC Waveforms

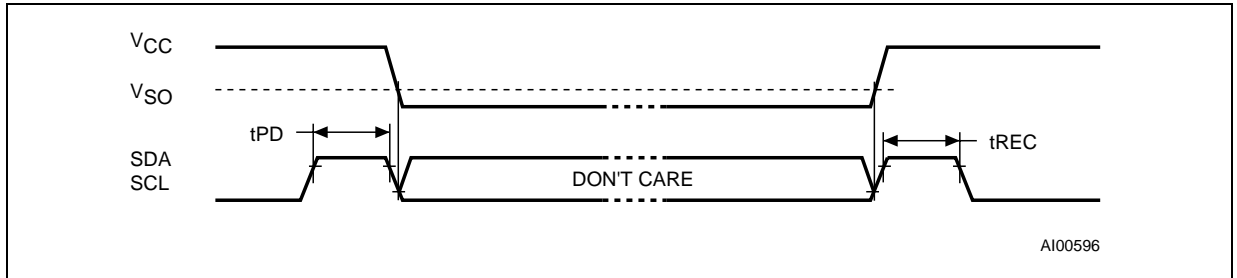

Table 8. Power Down/Up AC Characteristics

Symbol	Parameter ^(1,2)	Min	Typ	Max	Unit
t_{PD}	SCL and SDA at V_{IH} before Power Down	0			nS
t_{REC}	SCL and SDA at V_{IH} after Power Up	10			μ S

Note: 1. V_{CC} fall time should not exceed 5mV/ μ s.
 2. Valid for Ambient Operating Temperature: $T_A = -40$ to 85°C ; $V_{CC} = 2.0$ to 5.5V (except where noted).

Table 9. Power Down/Up Trip Points DC Characteristics

Sym	Parameter ^(1,2)	Min	Typ	Max	Unit
V_{SO}	Battery Back-up Switchover Voltage	$V_{BAT} - 0.80$	$V_{BAT} - 0.50$	$V_{BAT} - 0.30$	V
V_{RST}	Register Bit Reset Voltage	1.1		2.0	V

Note: 1. All voltages referenced to V_{SS} .
 2. Valid for Ambient Operating Temperature: $T_A = -40$ to 85°C ; $V_{CC} = 2.0$ to 5.5V (except where noted).

CLOCK OPERATION

The 20-byte Register Map (see Table 10, page 16) is used to both set the clock and to read the date and time from the clock, in a binary coded decimal format. Tenths/Hundredths of Seconds, Seconds, Minutes, and Hours are contained within the first four registers.

Note: A WRITE to any clock register will result in the Tenths/Hundredths of Seconds being reset to "00," and Tenths/Hundredths of Seconds cannot be written to any value other than "00."

Bits D6 and D7 of Clock Register 03h (Century/Hours Register) contain the CENTURY ENABLE Bit (CEB) and the CENTURY Bit (CB). Setting CEB to a '1' will cause CB to toggle, either from '0' to '1' or from '1' to '0' at the turn of the century (depending upon its initial state). If CEB is set to a '0,' CB will not toggle. Bits D0 through D2 of Register 04h contain the Day (day of week). Registers 05h, 06h, and 07h contain the Date (day of month), Month and Years. The ninth clock register is the Control Register (this is described in the Clock Calibration section). Bit D7 of Register 01h contains the STOP Bit (ST). Setting this bit to a '1' will cause the oscillator to stop. If the device is expected to spend a significant amount of time on the shelf, the oscillator may be stopped to reduce current drain. When reset to a '0' the oscillator restarts within one second.

The eight Clock Registers may be read one byte at a time, or in a sequential block. The Control Register (Address location 08h) may be accessed independently. Provision has been made to assure that a clock update does not occur while any of the

eight clock addresses are being read. If a clock address is being read, an update of the clock registers will be halted. This will prevent a transition of data during the READ.

Note: When a power failure occurs, the HT Bit will automatically be set to a '1.' This will prevent the clock from updating the TIMEKEEPER® registers, and will allow the user to read the exact time of the power-down event. Resetting the HT Bit to a '0' will allow the clock to update the TIMEKEEPER registers with the current time.

TIMEKEEPER® Registers

The M41T81 offers 20 internal registers which contain Clock, Alarm, Watchdog, Flag, Square Wave and Control data. These registers are memory locations which contain external (user accessible) and internal copies of the data (usually referred to as BiPORT™ TIMEKEEPER cells). The external copies are independent of internal functions except that they are updated periodically by the simultaneous transfer of the incremented internal copy. The internal divider (or clock) chain will be reset upon the completion of a WRITE to any clock address.

The system-to-user transfer of clock data will be halted whenever the address being read is a clock address (00h to 07h). The update will resume either due to a Stop Condition or when the pointer increments to any non-clock address (08h-13h).

TIMEKEEPER and Alarm Registers store data in BCD. Control, Watchdog and Square Wave Registers store data in Binary Format.

Table 10. TIMEKEEPER® Register Map

Addr									Function/Range BCD Format	
	D7	D6	D5	D4	D3	D2	D1	D0		
00h	0.1 Seconds				0.01 Seconds				Seconds	00-99
01h	ST	10 Seconds			Seconds				Seconds	00-59
02h	0	10 Minutes			Minutes				Minutes	00-59
03h	CEB	CB	10 Hours		Hours (24 Hour Format)				Century/ Hours	0-1/00-23
04h	0	0	0	0	0	Day of Week			Day	01-7
05h	0	0	10 Date		Date: Day of Month				Date	01-31
06h	0	0	0	10M	Month				Month	01-12
07h	10 Years				Year				Year	00-99
08h	OUT	FT	S	Calibration					Control	
09h	0	BMB4	BMB3	BMB2	BMB1	BMB0	RB1	RB0	Watchdog	
0Ah	AFE	SQWE	ABE	AI 10M	Alarm Month				AI Month	01-12
0Bh	RPT4	RPT5	AI 10 Date		Alarm Date				AI Date	01-31
0Ch	RPT3	HT	AI 10 Hour		Alarm Hour				AI Hour	00-23
0Dh	RPT2	Alarm 10 Minutes			Alarm Minutes				AI Min	00-59
0Eh	RPT1	Alarm 10 Seconds			Alarm Seconds				AI Sec	00-59
0Fh	WDF	AF	0	0	0	0	0	0	Flags	
10h	0	0	0	0	0	0	0	0	Reserved	
11h	0	0	0	0	0	0	0	0	Reserved	
12h	0	0	0	0	0	0	0	0	Reserved	
13h	RS3	RS2	RS1	RS0	0	0	0	0	SQW	

Keys: S = Sign Bit

FT = Frequency Test Bit

ST = Stop Bit

0 = Must be set to '0'

BMB0-BMB4 = Watchdog Multiplier Bits

CEB = Century Enable Bit

CB = Century Bit

OUT = Output level

ABE = Alarm in Battery Back-up Mode Enable Bit

AFE = Alarm Flag Enable Flag

RB0-RB1 = Watchdog Resolution Bits

RPT1-RPT5 = Alarm Repeat Mode Bits

WDF = Watchdog Flag (Read only)

AF = Alarm Flag (Read only)

SQWE = Square Wave Enable

RS0-RS3 = SQW Frequency

HT = Halt Update Bit

Calibrating the Clock

The M41T81 is driven by a quartz controlled oscillator with a nominal frequency of 32,768 Hz. The devices are tested not exceed -25 to $+45$ PPM (parts per million) oscillator frequency error at 25°C , which equates to about $+1.9$ to -1.1 minutes per month (see Figure 20, page 22). When the Calibration circuit is properly employed, accuracy improves to better than $+1/-2$ PPM at 25°C .

The oscillation rate of crystals changes with temperature. The M41T81 design employs periodic counter correction. The calibration circuit adds or subtracts counts from the oscillator divider circuit at the divide by 256 stage, as shown in Figure 21, page 22. The number of times pulses which are blanked (subtracted, negative calibration) or split (added, positive calibration) depends upon the value loaded into the five Calibration Bits found in the Control Register. Adding counts speeds the clock up, subtracting counts slows the clock down.

The Calibration Bits occupy the five lower order bits (D4-D0) in the Control Register 08h. These bits can be set to represent any value between 0 and 31 in binary form. Bit D5 is a Sign Bit; '1' indicates positive calibration, '0' indicates negative calibration. Calibration occurs within a 64 minute cycle. The first 62 minutes in the cycle may, once per minute, have one second either shortened by 128 or lengthened by 256 oscillator cycles. If a binary '1' is loaded into the register, only the first 2 minutes in the 64 minute cycle will be modified; if a binary 6 is loaded, the first 12 will be affected, and so on.

Therefore, each calibration step has the effect of adding 512 or subtracting 256 oscillator cycles for every 125,829,120 actual oscillator cycles, that is $+4.068$ or -2.034 PPM of adjustment per calibration step in the calibration register. Assuming that the oscillator is running at exactly 32,768 Hz, each of the 31 increments in the Calibration byte would represent $+10.7$ or -5.35 seconds per month

which corresponds to a total range of $+5.5$ or -2.75 minutes per month.

Two methods are available for ascertaining how much calibration a given M41T81 may require.

The first involves setting the clock, letting it run for a month and comparing it to a known accurate reference and recording deviation over a fixed period of time. Calibration values, including the number of seconds lost or gained in a given period, can be found in Application Note AN934, "TIMEKEEPER[®] CALIBRATION." This allows the designer to give the end user the ability to calibrate the clock as the environment requires, even if the final product is packaged in a non-user serviceable enclosure. The designer could provide a simple utility that accesses the Calibration byte.

The second approach is better suited to a manufacturing environment, and involves the use of the $\overline{\text{IRQ}}/\text{FT}/\text{OUT}/\text{SQW}$ pin. The pin will toggle at 512Hz, when the Stop Bit (ST, D7 of 01h) is '0,' the Frequency Test Bit (FT, D6 of 08h) is '1,' the Alarm Flag Enable Bit (AFE, D7 of 0Ah) is '0,' and the Square Wave Enable Bit (SQWE, D6 of 0Ah) is '0' and the Watchdog Register (09h = 0) is reset.

Any deviation from 512 Hz indicates the degree and direction of oscillator frequency shift at the test temperature. For example, a reading of 512.010124 Hz would indicate a $+20$ PPM oscillator frequency error, requiring a -10 (XX001010) to be loaded into the Calibration Byte for correction. Note that setting or changing the Calibration Byte does not affect the Frequency Test output frequency.

The $\overline{\text{IRQ}}/\text{FT}/\text{OUT}/\text{SQW}$ pin is an open drain output which requires a pull-up resistor to V_{CC} for proper operation. A 500-10k resistor is recommended in order to control the rise time. The FT Bit is cleared on power-down.

Setting Alarm Clock Registers

Address locations 0Ah-0Eh contain the alarm settings. The alarm can be configured to go off at a prescribed time on a specific month, date, hour, minute, or second or repeat every year, month, day, hour, minute, or second. It can also be programmed to go off while the M41T81 is in the battery back-up mode to serve as a system wake-up call.

Bits RPT5-RPT1 put the alarm in the repeat mode of operation. Table 11, page 19 shows the possible configurations. Codes not listed in the table default to the once per second mode to quickly alert the user of an incorrect alarm setting.

When the clock information matches the alarm clock settings based on the match criteria defined by RPT5-RPT1, the AF (Alarm Flag) is set. If AFE (Alarm Flag Enable) is also set (and SQWE is '0.'), the alarm condition activates the $\overline{\text{IRQ/FT/OUT/SQW}}$ pin.

Note: If the address pointer is allowed to increment to the Flag Register address, an alarm condition will not cause the Interrupt/Flag to occur until the address pointer is moved to a different address. It should also be noted that if the last address written is the "Alarm Seconds," the address pointer will increment to the Flag address, causing this situation to occur.

The $\overline{\text{IRQ/FT/OUT/SQW}}$ output is cleared by a READ to the Flags Register as shown in Figure 18. A subsequent READ of the Flags Register is necessary to see that the value of the Alarm Flag has been reset to '0.'

The $\overline{\text{IRQ/FT/OUT/SQW}}$ pin can also be activated in the battery back-up mode. The $\overline{\text{IRQ/FT/OUT/SQW}}$ will go low if an alarm occurs and both ABE (Alarm in Battery Back-up Mode Enable) and AFE are set. Figure 19 illustrates the back-up mode alarm timing.

Figure 18. Alarm Interrupt Reset Waveform

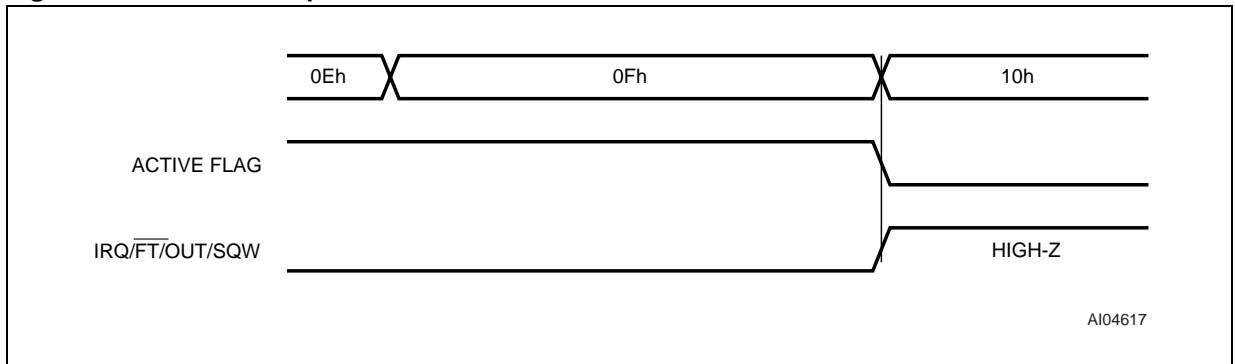

Figure 19. Back-up Mode Alarm Waveform

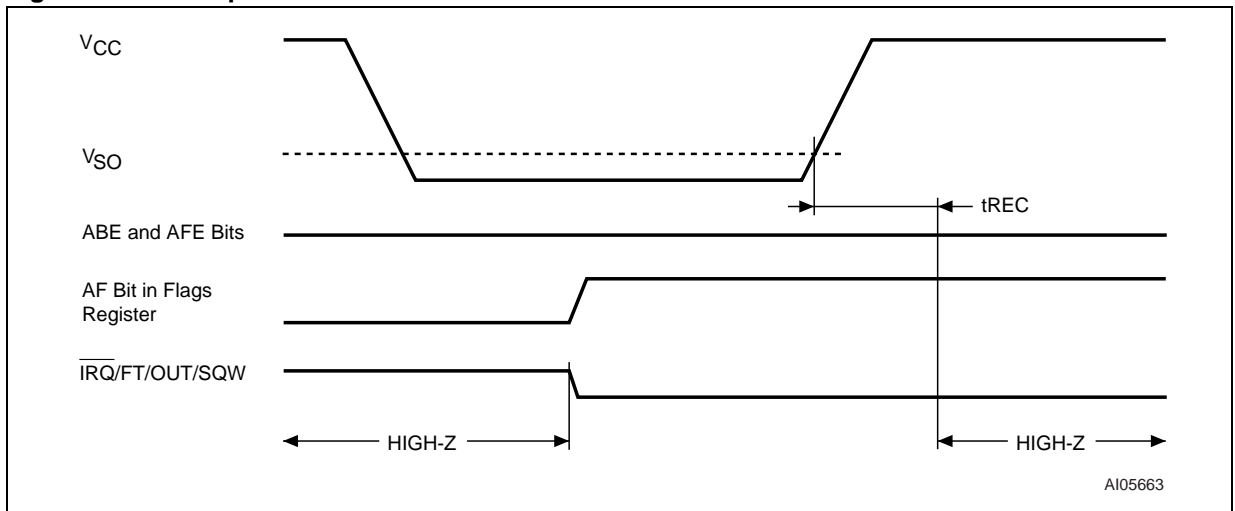

Table 11. Alarm Repeat Modes

RPT5	RPT4	RPT3	RPT2	RPT1	Alarm Setting
1	1	1	1	1	Once per Second
1	1	1	1	0	Once per Minute
1	1	1	0	0	Once per Hour
1	1	0	0	0	Once per Day
1	0	0	0	0	Once per Month
0	0	0	0	0	Once per Year

Watchdog Timer

The watchdog timer can be used to detect an out-of-control microprocessor. The user programs the watchdog timer by setting the desired amount of time-out into the Watchdog Register, address 09h. Bits BMB4-BMB0 store a binary multiplier and the two lower order bits RB1-RB0 select the resolution, where 00 = 1/16 second, 01 = 1/4 second, 10 = 1 second, and 11 = 4 seconds. The amount of time-out is then determined to be the multiplication of the five-bit multiplier value with the resolution. (For example: writing 00001110 in the Watchdog Register = 3×1 , or 3 seconds). If the processor does not reset the timer within the specified period, the M41T81 sets the WDF (Watchdog Flag) and generates a watchdog interrupt.

The watchdog timer can be reset by having the microprocessor perform a WRITE of the Watchdog Register. The time-out period then starts over.

Should the watchdog timer time-out, a value of 00h needs to be written to the Watchdog Register in order to clear the IRQ/FT/OUT/SQW pin. This will also disable the watchdog function until it is again programmed correctly. A READ of the Flags Register will reset the Watchdog Flag (Bit D7; Register 0Fh).

The watchdog function is automatically disabled upon power-up and the Watchdog Register is cleared. If the watchdog function is set, the frequency test function is activated, and the SQWE Bit is '0,' the watchdog function prevails and the frequency test function is denied.

Square Wave Output

The M41T81 offers the user a programmable square wave function which is output on the SQW pin. RS3-RS0 bits located in 13h establish the square wave output frequency. These frequencies are listed in Table 12. Once the selection of the

SQW frequency has been completed, the $\overline{\text{IRQ/FT/OUT/SQW}}$ pin can be turned on and off under software control with the Square Wave Enable Bit (SQWE) located in Register 0Ah.

Table 12. Square Wave Output Frequency

Square Wave Bits				Square Wave	
RS3	RS2	RS1	RS0	Frequency	Units
0	0	0	0	None	-
0	0	0	1	32.768	kHz
0	0	1	0	8.192	kHz
0	0	1	1	4.096	kHz
0	1	0	0	2.048	kHz
0	1	0	1	1.024	kHz
0	1	1	0	512	Hz
0	1	1	1	256	Hz
1	0	0	0	128	Hz
1	0	0	1	64	Hz
1	0	1	0	32	Hz
1	0	1	1	16	Hz
1	1	0	0	8	Hz
1	1	0	1	4	Hz
1	1	1	0	2	Hz
1	1	1	1	1	Hz

Century Bit

Bits D7 and D6 of Clock Register 03h contain the CENTURY ENABLE Bit (CEB) and the CENTURY Bit (CB). Setting CEB to a '1' will cause CB to toggle, either from a '0' to '1' or from '1' to '0' at the turn of the century (depending upon its initial state). If CEB is set to a '0,' CB will not toggle.

Output Driver Pin

When the FT Bit, AFE Bit, SQWE Bit, and Watchdog Register are not set, the $\overline{\text{IRQ}}/\text{FT}/\text{OUT}/\text{SQW}$ pin becomes an output driver that reflects the contents of D7 of the Control Register. In other words, when D7 (OUT Bit) and D6 (FT Bit) of address lo-

cation 08h are a '0,' then the $\overline{\text{IRQ}}/\text{FT}/\text{OUT}/\text{SQW}$ pin will be driven low.

Note: The $\overline{\text{IRQ}}/\text{FT}/\text{OUT}/\text{SQW}$ pin is an open drain which requires an external pull-up resistor.

Preferred Initial Power-on Default

Upon initial application of power to the device, the following register bits are set to a '0' state: Watchdog Register; AFE; ABE; SQWE; and FT. The following bits are set to a '1' state: ST; OUT; and HT (see Table 13, page 21).

Table 13. Preferred Default Values

Condition	ST	HT	Out	FT	AFE	SQWE	ABE	WATCHDOG Register ⁽¹⁾
Initial Power-up ⁽²⁾	1	1	1	0	0	0	0	0
Subsequent Power-up (with battery back-up) ⁽³⁾	UC	1	UC	0	UC	UC	UC	0

Note: 1. BMB0-BMB4, RB0, RB1.

2. State of other control bits undefined.

3. UC = Unchanged

Figure 20. Crystal Accuracy Across Temperature

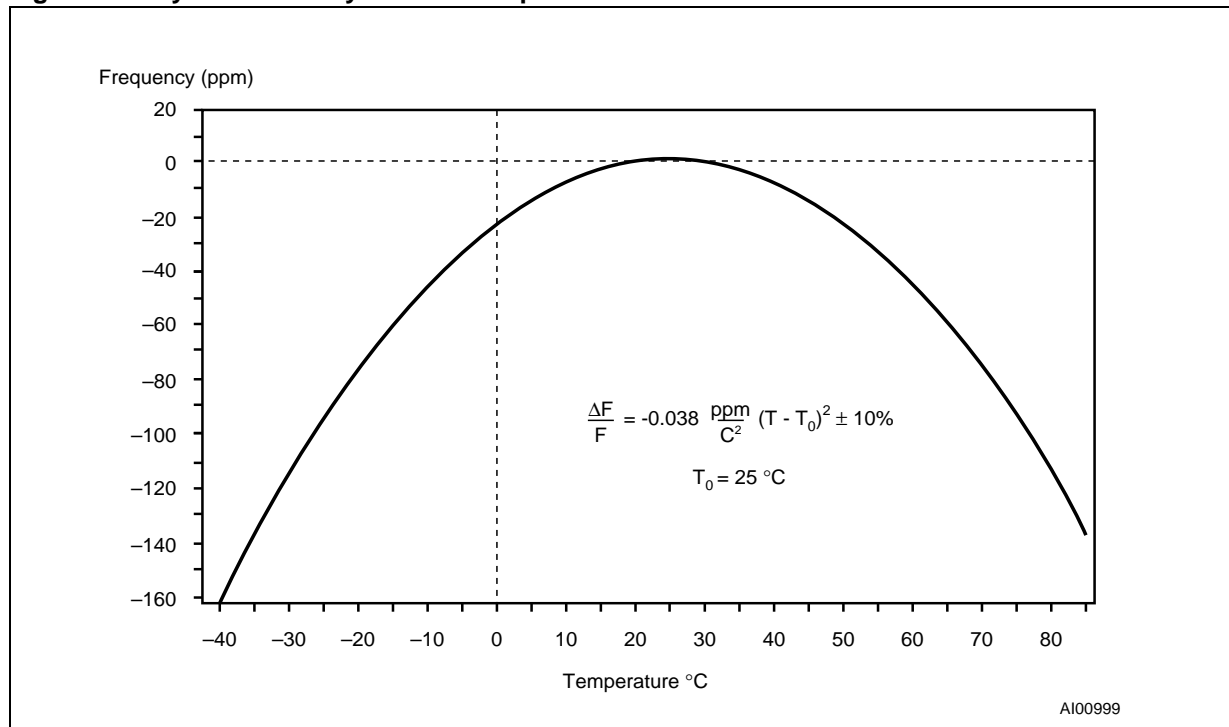
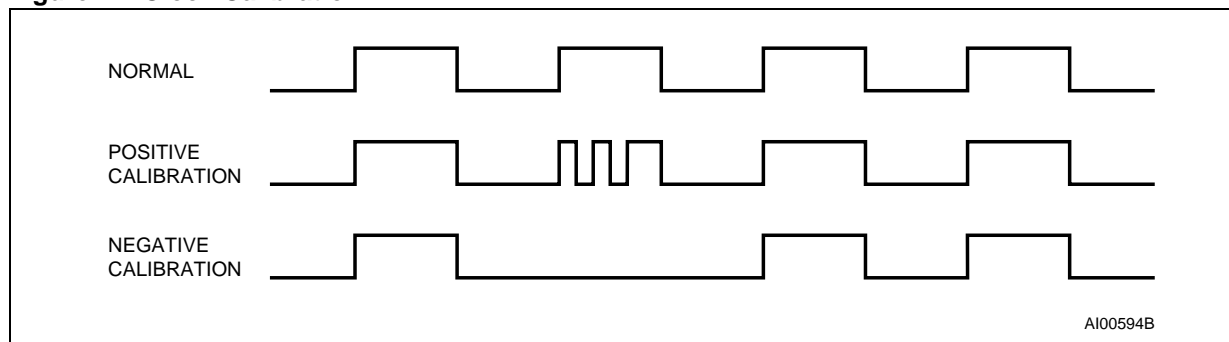
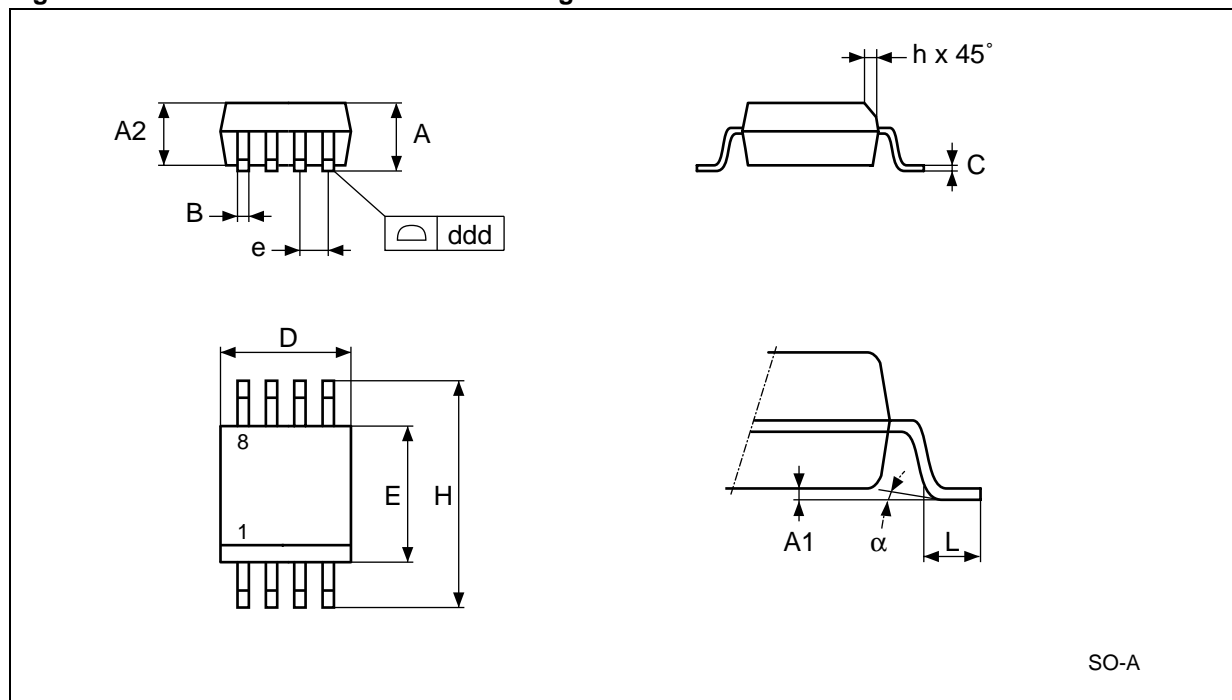

Figure 21. Clock Calibration



PACKAGE MECHANICAL INFORMATION

Figure 22. SO8 – 8-lead Plastic Small Package Outline



Note: Drawing is not to scale.

Table 14. SO8 – 8-lead Plastic Small Outline (150 mils body width), Package Mechanical Data

Symb	mm			inches		
	Typ	Min	Max	Typ	Min	Max
A		1.35	1.75		0.053	0.069
A1		0.10	0.25		0.004	0.010
A2		1.10	1.65		0.043	0.065
B		0.33	0.51		0.013	0.020
C		0.19	0.25		0.007	0.010
D		4.80	5.00		0.189	0.197
E		3.80	4.00		0.150	0.157
e	1.27	–	–	0.050	–	–
H		5.80	6.20		0.228	0.244
h		0.25	0.50		0.010	0.020
L		0.40	0.90		0.016	0.035
α		0°	8°		0°	8°
N		8			8	
ddd			0.10			0.004

Figure 23. SOX18 – 18-lead Plastic Small Outline, 300mils, Embedded Crystal, Package Outline

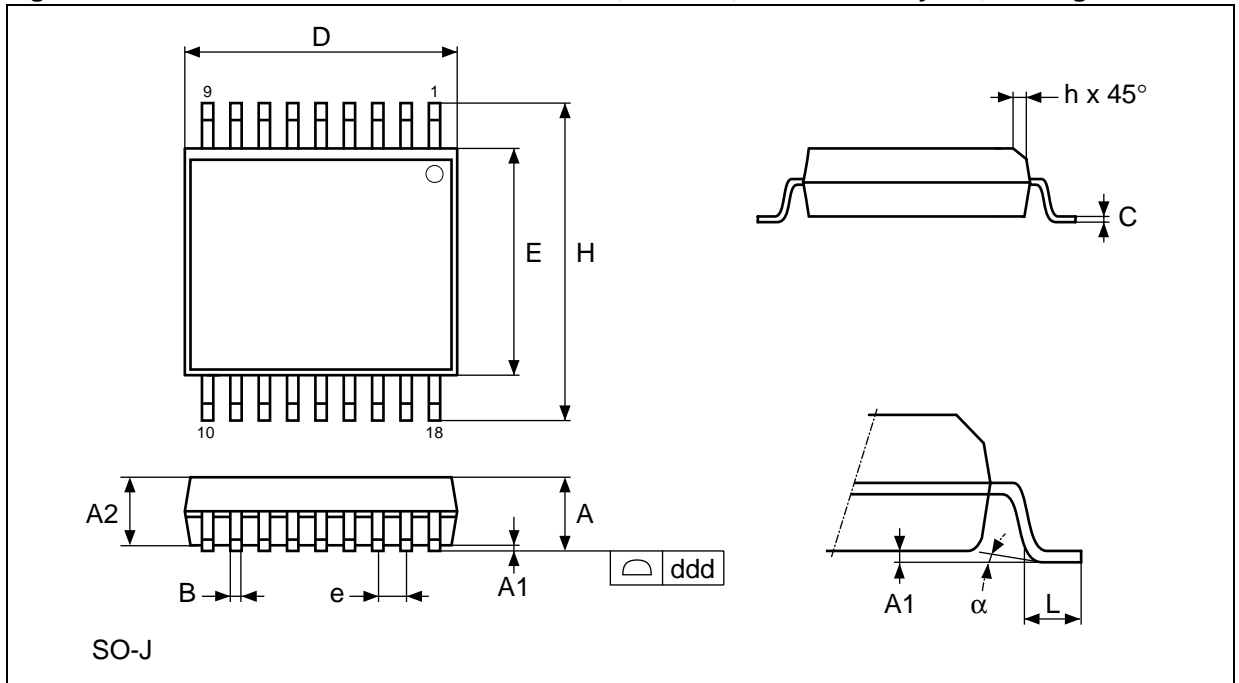

Note: Drawing is not to scale.

Table 15. SOX18 – 18-lead Plastic Small Outline, 300mils, Embedded Crystal, Package Mechanical

Symbol	millimeters			inches		
	Typ	Min	Max	Typ	Min	Max
A		2.44	2.69		0.096	0.106
A1		0.15	0.31		0.006	0.012
A2		2.29	2.39		0.090	0.094
B		0.41	0.51		0.016	0.020
C		0.20	0.31		0.008	0.012
D	11.61	11.56	11.66	0.457	0.455	0.459
ddd			0.10			0.004
E		7.57	7.67		0.298	0.302
e	1.27	–	–	0.050	–	–
H		10.16	10.52		0.400	0.414
L		0.51	0.81		0.020	0.032
α		0°	8°		0°	8°
N		18			18	

Figure 24. SOX28 – 28-lead Plastic Small Outline, 300mils, Embedded Crystal, Package Outline

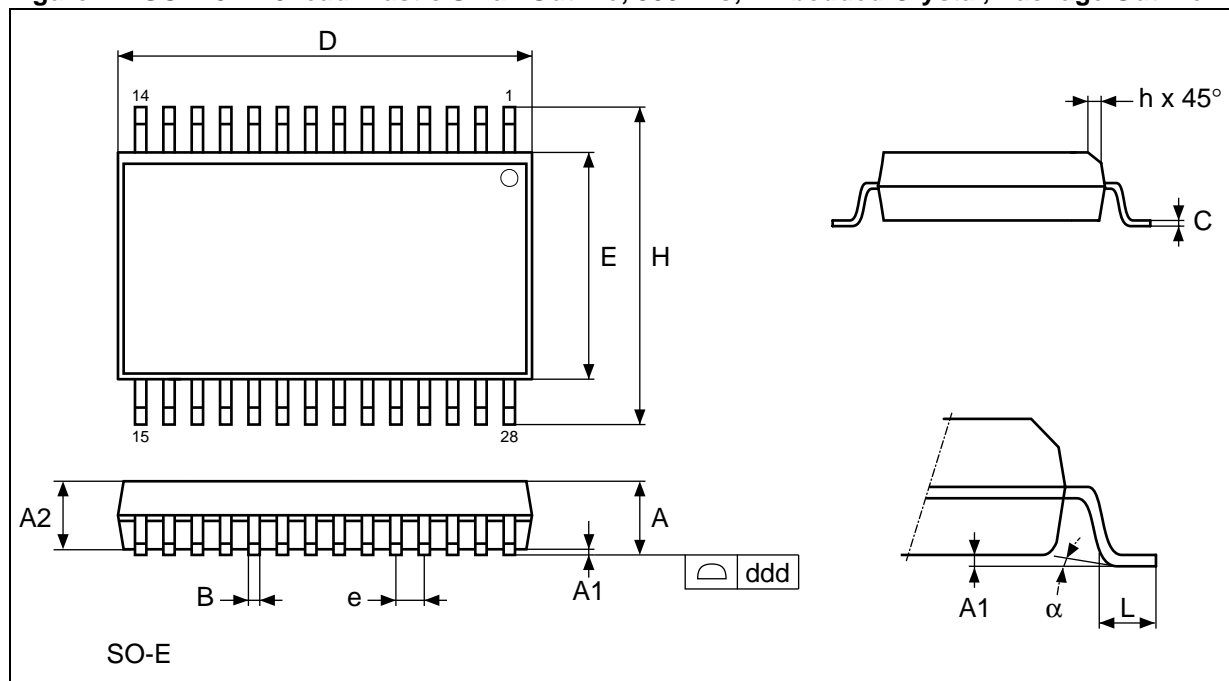

Note: Drawing is not to scale.

Table 16. SOX28 – 28-lead Plastic Small Outline, 300mils, Embedded Crystal, Package Mechanical

Symbol	millimeters			inches		
	Typ	Min	Max	Typ	Min	Max
A		2.44	2.69		0.096	0.106
A1		0.15	0.31		0.006	0.012
A2		2.29	2.39		0.090	0.094
B		0.41	0.51		0.016	0.020
C		0.20	0.31		0.008	0.012
D		17.91	18.01		0.705	0.709
ddd			0.10			0.004
E		7.57	7.67		0.298	0.302
e	1.27	–	–	0.050	–	–
H		10.16	10.52		0.400	0.414
L		0.51	0.81		0.020	0.032
α		0°	8°		0°	8°
N		28			28	

PART NUMBERING

Table 17. Ordering Information Scheme

Example:	M41T	81	M	6	TR
Device Type M41T					
Supply Voltage and Write Protect Voltage 81 = $V_{CC} = 2.0$ to $5.5V$					
Package M = SO8 MX ⁽¹⁾ = SOX28 MY ⁽¹⁾ = SOX18					
Temperature Range 6 = $-40^{\circ}C$ to $85^{\circ}C$					
Shipping Method for SOIC blank = Tubes TR = Tape & Reel					

Note: 1. The SOX28 and SOX18 packages include an embedded 32,768Hz crystal.

For a list of available options (e.g., Speed, Package) or for further information on any aspect of this device, please contact the ST Sales Office nearest to you.

REVISION HISTORY

Table 18. Document Revision History

Date	Rev. #	Revision Details
December 2001	1.0	First Issue
21-Jan-02	1.1	Fix table footnotes (Table 5, 6)
01-May-02	1.2	Modify reflow time and temperature footnote (Table 2)
05-Jun-02	1.3	Modify Data Retention text, Trip Points (Table 9)
10-Jun-02	1.4	Corrected Supply Voltage values (Table 2, 3)
03-Jul-02	1.5	Modify DC Characteristics, Crystal Electrical table footnotes, Preferred Default Values (Table 5, 6, 13)
11-Oct-02	1.6	Add marketing status (Figure 3; Table 17); adjust footnotes (Figure 5; Table 5)
21-Jan-03	1.7	Add embedded crystal package option (Figure 2, 7, 24; Table 16); modified pre-existing mechanical drawing (Figure 22; Table 14).
05-Mar-03	1.8	Correct dimensions (Figure 24; Table 16); remove SNAPHAT® package option
12-Sep-03	2.0	Updated disclaimer, v2.2 template; add SOX18 package (Figure 3, 6, 23; Table 17, 15)

Information furnished is believed to be accurate and reliable. However, STMicroelectronics assumes no responsibility for the consequences of use of such information nor for any infringement of patents or other rights of third parties which may result from its use. No license is granted by implication or otherwise under any patent or patent rights of STMicroelectronics. Specifications mentioned in this publication are subject to change without notice. This publication supersedes and replaces all information previously supplied. STMicroelectronics products are not authorized for use as critical components in life support devices or systems without express written approval of STMicroelectronics.

The ST logo is a registered trademark of STMicroelectronics.
All other names are the property of their respective owners

© 2003 STMicroelectronics - All rights reserved

STMicroelectronics GROUP OF COMPANIES

Australia - Belgium - Brazil - Canada - China - Czech Republic - Finland - France - Germany - Hong Kong - India - Israel - Italy - Japan -
Malaysia - Malta - Morocco - Singapore - Spain - Sweden - Switzerland - United Kingdom - United States

www.st.com