

MITSUBISHI SEMICONDUCTORS
M63023/024/026/027FP
SPINDLE MOTOR AND 5CH ACTUATOR driver

[FEATURES]

This IC is 1 chip driver IC for spindle motor and 5 channel actuators. All of the motor and actuator of optical disk drive system (CD-ROM etc.) can be driven by only this IC.

This IC has a direct PWM control system for Spindle and Slide channels drive due to reducing IC power dissipation.

This IC has three Voltage supply terminals (for Spindle,Slide,Focus/Tracking and Loading), and three voltage supply can be set separately.

Further more this IC has short braking select function,FG amplifier, thermal shut down circuit, standby circuit, reverse rotation detect circuit.

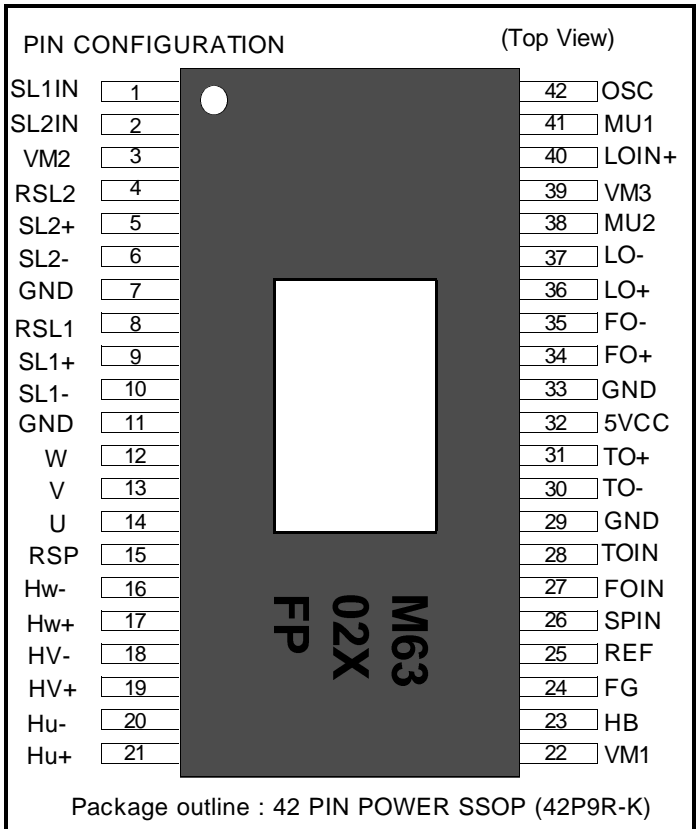

[APPLICATION]

CD-ROM, CD-R/RW,DVD, DVD-ROM, DVD-RAM ,Optical disc related system,etc

[BLOCK DIAGRAM]

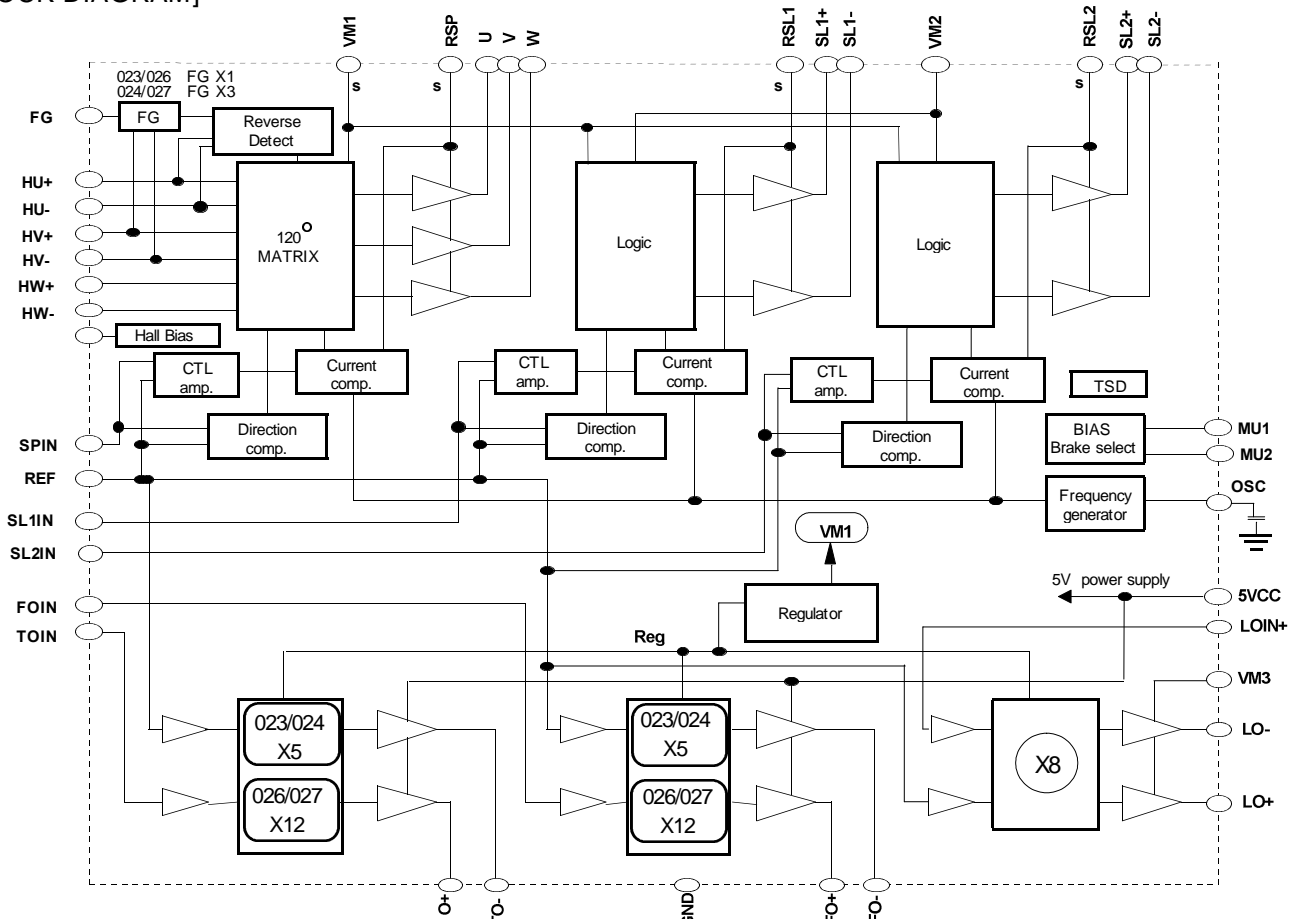

MITSUBISHI SEMICONDUCTORS
M63023/024/026/027FP
SPINDLE MOTOR AND 5CH ACTUATOR driver

[PIN FUNCTION]

TERMINAL	SYMBOL	TERMINAL FUNCTION	TERMINAL	SYMBOL	TERMINAL FUNCTION
1	SL1IN	Slide control Voltage input 1	42	OSC	PWM carrier oscilation set
2	SL2IN	Slide control Voltage input 2	41	MU1	mute /break select terminal 1
3	VM2	Motor Power Suppry 2(for Slide)	40	LOIN+	Loading control input(+)
4	RSL2	Slide current sense 2	39	VM3	Power Supply3(for Loading)
5	SL2+	Slide non-inverted output 2	38	MU2	mute /break select terminal 2
6	SL2-	Slide inverted output 2	37	LO-	Loading inverted output
7	GND	GND	36	LO+	Loading non-inverted output
8	RSL1	Slide current sense 1	35	FO-	Focus inverted output
9	SL1+	Slide non-inverted output 1	34	FO+	Focus non-inverted output
10	SL1-	Slide inverted output 1	33	GND	GND
11	GND	GND	32	5VCC	5V Power Supply(for FS ,TS)
12	W	Motor drive output W	31	TO+	Tracking non-inverted output
13	V	Motor drive output V	30	TO-	Tracking inverted output
14	U	Motor drive output U	29	GND	GND
15	RSP	Spindle current sensie	28	TOIN	Tracking control Voltage input
16	HW-	HW- sensor amp. input	27	FOIN	Focus control Voltage input
17	HW+	HW+ sensor amp. input	26	SPIN	Spindle control Voltage input
18	HV-	HV- sensor amp. input	25	REF	Reference Voltage input
19	HV+	HV+ sensor amp. input	24	FG	Frequency generator output
20	HU-	HU- sensor amp. input	23	HB	Bias for Hall Sensor
21	HU+	HU+ sensor amp. input	22	VM1	Motor Power Suppry 1(for Spindle)

[FUNCTION]

	FO,TO Gain	FG Pulse
M63023FP	5 (V/V)	X 1 (6pulse/rot.)
M63024FP	5 (V/V)	X 3 (18pulse/rot.)
M63026FP	12 (V/V)	X 1 (6pulse/rot.)
M63027FP	12 (V/V)	X 3 (18pulse/rot.)

mitsubishi semiconductors
M63023/024/026/027FP
SPINDLE MOTOR AND 5CH ACTUATOR driver

[ABSOLUTE MAXIMUM RATING] (Ta=25°C)

SYMBOL	PARAMETER	CONDITIONS	RATING	Unit
5VCC	5V power supply	Focus and Tracking power supply	7	V
VM1	Motor power supply 1	Spindle power supply *note 1	15	V
VM2	Motor power supply 2	Slide power supply	15	V
VM3	Motor power supply 3	Loading power supply	15	V
IoA	Motor Output Current A	Focus, Tracking and Loading output current *note 1	1.0	A
IoB	Motor Output Current B	Spindle output current *note 1	1.5	A
IoC	Motor Output Current C	Slide output current *note 1	0.5	A
Vin	Maximum input Voltage of terminals	MU1, Hw-, Hw+, HV, HV+, Hu-, Hu+, REF, SPIN, MU2 TOIN, FOIN, OSC, SLIN1, SLIN2, LOIN+	0 ~ 5VCC	V
Pt	Power dissipation	Free Air and on the grass epoxy board	2.6	W
Kθ	Thermal derating	Free Air and on the grass epoxy board	20.8	mW / °C
Tj	Junction temperature		150	°C
Topr	Operating temperature		-20 ~ +75	°C
Tstg	Storage temperature		-40 ~ +150	°C

*note1 ; The ICs must be operated within the Pt (power dissipation) or the area of safety operation. In case of the spindle motor to repeat acceleration and deceleration, the spindle output voltage become over the area of safety operation. Therefore the spindle channel please insert capacitor between each spindle output terminals. (we recommend capacitor value is 6.8nF.)

[RECOMMENDED OPERATING CONDITIONS] (Ta=25°C)

SYMBOL	PARAMETER	LIMITS			Unit
		minimum	typical	maximum	
VM1	VM1 power supply (f or Spindle)	6	12	13.2	V
VM2	VM2 power supply (f or Slide)	4.5	12	13.2	V
VM3	VM3 power supply (f or Loading)	4.5	12	13.2	V
5VCC	5V power supply (f or FS, TS)	4.5	5	7	V
IoA	Focus, Tracking and Loading Output Current	—	0.5	0.8	A
IoB	Spindle Output Current	—	0.5	1.0	A
IoC	Slide Output Current	—	0.25	0.4	A
Fosc	PWM carrier frequency	30	—	120	KHz

mitsubishi Semiconductors
M63023/024/026/027FP
SPINDLE MOTOR AND 5CH ACTUATOR driver

[THERMAL DERATING]

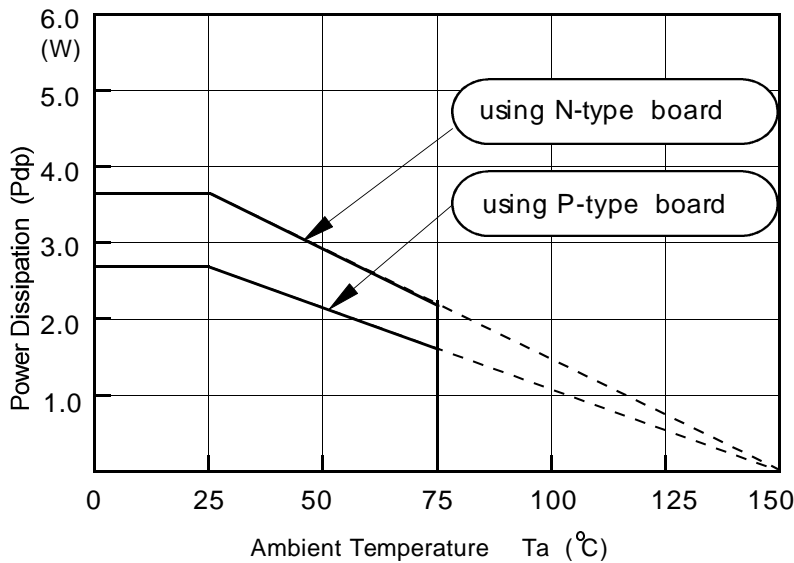

This IC's package is POWER-SSOP, so improving the board on which the IC is mounted enables a large power dissipation without a heat sink

For example, using an 1 layer glass epoxy resin board, the IC's power dissipation is 2.6W at least. And it comes to 3.6W by using an improved 2 layer board.

The information of the N, P type board is shown in attached.

[ELECTRICAL CHARACTERISTICS]

Common

(Ta=25°C, 5VCC=VM3=5V, VM1=VM2=12V unless otherwise noted.)

SYMBOL	PARAMETER	CONDITIONS	LIMITS			Unit
			MIN	TYP	MAX	
Icc1	Supply current	5VCC, VM1, VM2, VM3 current	—	55	72	mA
Icc2	Sleep current	5VCC, VM1, VM2, VM3 current under Sleep (MU1=MU2 = 0V).	—	0	30	uA
Fosc	PWM carrier frequency	OSC : with 330pF	—	65	—	KHz
VinREF	REF input Voltage range		1.0	—	3.3	V
IinREF	REF terminal input current	VREF=1.65V	-10	—	+10	uA
VMU1LO	MUTE1 terminal low Voltage	MU1	—	—	0.8	V
VMU1HI	MUTE1 terminal high Voltage	MU1	2.5	—	—	V
IM1U	MUTE1 terminal input current	MU1 at 5V input Voltage	—	—	500	uA
VMU2LO	MUTE2 terminal low Voltage	MU2	—	—	0.8	V
VMU2HI	MUTE2 terminal high Voltage	MU2	2.5	—	—	V
IM2U	MUTE2 terminal input current	MU2 at 5V input Voltage	—	—	500	uA

mitsubishi semiconductors
M63023/024/026/027FP
SPINDLE MOTOR AND 5CH ACTUATOR driver

[ELECTRICAL CHARACTERISTICS]

Spindle

(Ta=25°C, 5VCC=VM3=5V,VM1=VM2=12V unless otherwise noted.)

SYMBOL	PARAMETER	CONDITIONS	LIMITS			Unit
			MIN	TYP	MAX	
Vdyc1	Dynamic range of output	Io=0.5 [A]	10.6	11.1	—	v
Vdead1-	Control Voltage dead zone 1	SPIN<REF [Reverse]	-80	-40	0	mV
Vdead1+		REF<SPIN [FORWARD]	0	+40	+80	mV
Vin1	Control Voltage input range 1	SPIN	0	—	5	v
GVo1	Control gain 1	Gio1=GVo1/ Rs [A/V]	0.85	1.0	1.15	V/V
Vlim1F	Control limit 1F	Ilim1F=Vlim1F/ Rs [A]	0.4	0.5	0.6	v
Vlim1R	Control limit 1R	Ilim1R=Vlim1R/ Rs [A]	0.22	0.28	0.34	v
VHcom	Hall sensor amp. common mode input range	Hu+,Hu-,HV+,HV-,Hw+,Hw-	1.3	—	3.7	v
VHmin	Hall sensor amp. input signal level	Hu+,Hu-,HV+,HV-,Hw+,Hw-	60	—	—	mVp-p
VHB	HB output Voltage	at Load current (IHB)=10mA	0.6	0.85	1.2	v
IHB	HB terminal sink current	MU1=5V	—	—	30	mA

Slide 1,2

(Ta=25°C, 5VCC=VM3=5V,VM1=VM2=12V unless otherwise noted.)

SYMBOL	PARAMETER	CONDITIONS	LIMITS			Unit
			MIN	TYP	MAX	
Vdyc2	Dynamic range of output	Io=0.5 [A] at VM2=5[V] RSL=0.9ohm at VM2=12[V]	3.75 10.3	3.95 10.8	— —	v
Vdead2-	Control Voltage dead zone 2	SL1IN,SL2IN < REF	-80	-40	0	mV
Vdead2+		REF < SL1IN,SL2IN	0	+40	+80	mV
Vin2	Control Voltage input range 2	SL1IN,SL2IN	0	—	5	v
GVo2	Control gain 2	Gio2=GVo2/ Rs [A/V]	0.85	1.0	1.15	V/V
Vlim2	Control limit 2	Ilim2=Vlim2/ Rs [A]	0.43	0.5	0.58	v
Tdon	Output turn-on delay	Time after RS is greater than an input instruction value, while an output turns on.	—	1.0	2.0	usec
Tdoff	Output turn-off delay	Time after RS is less than an input instruction value, while an output turns off.	—	2.0	3.5	usec
Tdsw	Output switching delay	All output off time at the time of the output drive direction change	—	3.0	6.0	usec
Ileak	Output leak current	MU1=MU2=0V	-100	—	100	uA

mitsubishi semiconductors
M63023/024/026/027FP
SPINDLE MOTOR AND 5CH ACTUATOR driver

[ELECTRICAL CHARACTERISTICS]

Loading

(Ta=25°C, 5VCC=VM3=5V, VM1=VM2=12V unless otherwise noted.)

SYMBOL	PARAMETER	CONDITIONS	LIMITS			Unit
			MIN	TYP	MAX	
Vdy c3-1	Dynamic range of output	VM1=12[V] VM3=5[V] Io=0.5A	3.95	4.20	—	V
			6.9	7.6	—	
Vdy c3-2	Dynamic range of output	R=5.4[ohm] VM3=4.75V , VM1=12V	3.35	3.55	—	V
Vin3	Control Voltage input range3	LOIN+	0	—	5	V
GVo3	Control gain 3	$\frac{(LO+) - (LO-)}{(LOIN+) - (REF)}$	16.7	18.1	19.3	dB
Voff 1	Output off set Voltage	(LO+) - (LO-) at LOIN+=REF=1.65V	-50	0	+50	mV

Focus / Tracking

(Ta=25°C, 5VCC=VM3=5V, VM1=VM2=12V unless otherwise noted.)

SYMBOL	PARAMETER	CONDITIONS	LIMITS			Unit	
			MIN	TYP	MAX		
Vdy c4	Dynamic range of output	VM1=12[V] Io=0.5[A]	4.0	4.25	—	V	
			3.55	3.95	—		
Vin4	Control Voltage input range 4	FOIN, TOIN	0	—	5	V	
GVo4	Control gain 4	$\frac{(FO+) - (FO-)}{FOIN - REF}$	M63023/024FP	12.6	14.0	15.2	dB
		$\frac{(TO+) - (TO-)}{TOIN - REF}$	M63026/027FP	20.2	21.6	22.8	
Voff 2	Output off set Voltage	(FO+) - (FO-) at REF=FOIN=1.65V (TO+) - (TO-) at REF=TOIN=1.65V	-30	0	+30	mV	

NOTE : This IC need condenser between each supply lines and GND for stoped Oscillation.

[THERMAL CHARACTERISTICS]

SYMBOL	PARAMETER	FUNCTION START TEMPERATURE OF IC			FUNCTION STOP TEMPERATURE OF IC			Unit
		MIN	TYP	MAX	MIN	TYP	MAX	
TSD	Thermal Shut Down	—	165	—	—	130	—	°C

*note3

This TSD function start temperature doesn't show the guaranteed max. temperature of the device. The guranteed max. temperature is Tj max. which is shown in "9. ABSOLUTE MAXIMUM RATING". The TSD function is a thermal protection in case the temperature of the device goes up above Tjmax because of wrong use.

And these TSD temperature are the target temperatures for circuit design, not the guranteed temperatures. (The TSD function of all the device is not checked by a test in high temperature.)

○ Channel select function

	Logic control		drive channel						Brake select (SPIN<REF)
	MU1	MU2	Loading	Slide1	Slide2	Forcus	Tracking	Spindle	
SELECT4	H	H	Off	On	On	On	On	On	PWM
SELECT3	H	L	Off	On	On	On	On	On	Short
SELECT2	L	H	On	Off	Off	Off	Off	Off	--
SELECT1	L	L	Off	Off	Off	Off	Off	Off	--

This IC has two MUTE terminal (MU1 and MU2).

It is possible to control ON / OFF of each channel by external logic inputs.

It has four kinds of function for select. In case of SELECT1, the bias of all circuit becomes OFF.

Therefore, this mode is available in order to reduce the power dissipation when the waiting mode.

In case of SELECT2, the bias of other than Loading circuit becomes OFF.

Therefore, this mode is available in order to reduce the power dissipation when the active mode.

In case of SELECT3, it is possible to select the short braking to take the brake of Spindle motor.

Also, in case of SELECT4, it is possible to select PWM reverse braking when in the same.

○ Loading channel

The loading channel is the circuit of BTL Voltage drive.

This circuit has the referential input.

Output swing is determined with $\Delta V_{in} \times 8$. Also, it is possible for this channel to use for the slide motor, the focus coil and the tracking coil.

The input terminal is high impedance.

It is possible to do variable gain by external resistor.

In case of one MCU port, if use three state port,

it is possible for this channel to have the stop function.

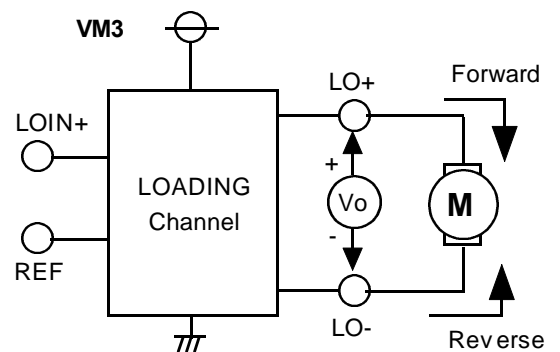

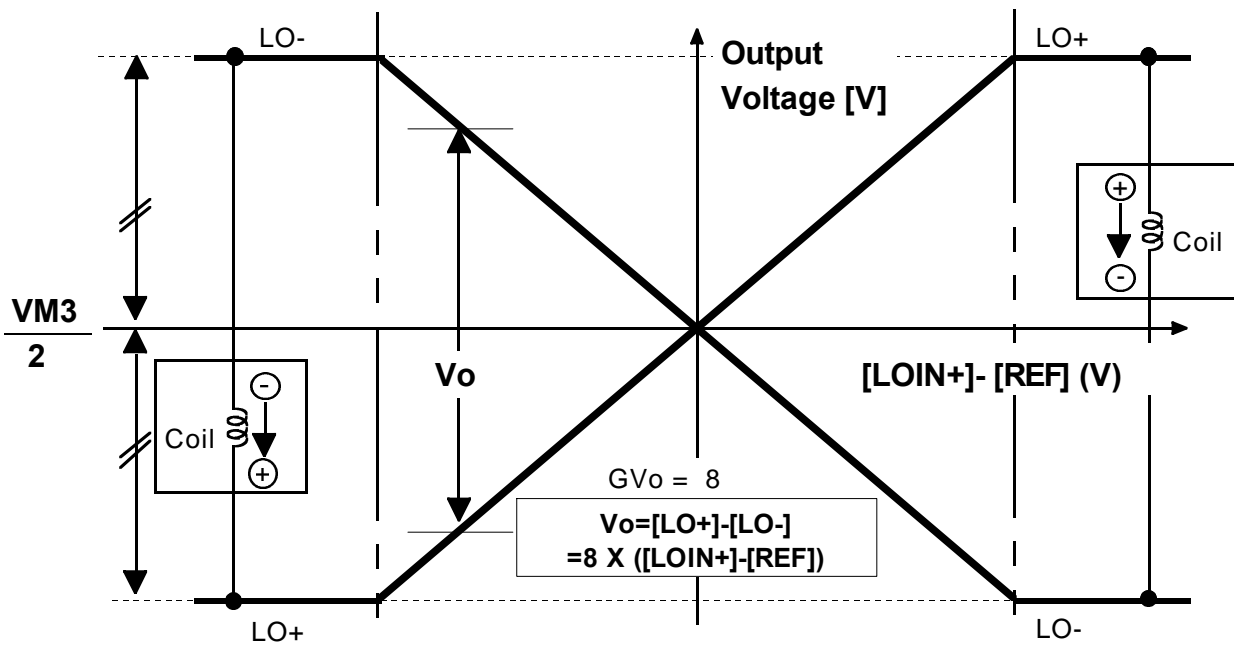

application.1 : One port H/Z/L control)

Logic control P1	Situation of loading channel	Output Voltage swing
5V	Forward rotation	$V_o = \frac{8 \times (5[V] - REF[V])}{XR2 / (R1 + R2)}$
Z (Hi impedance)	Short brake --> Stop	$V_o = 0 [V]$
0	Reverse rotation	$V_o = \frac{-8 \times (5[V] - REF[V])}{XR2 / (R1 + R2)}$

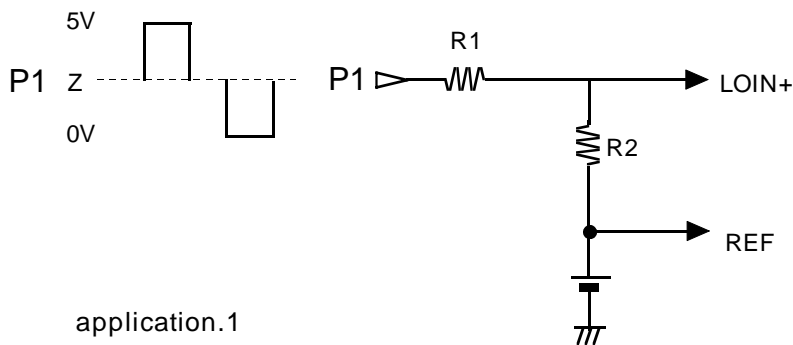

MITSUBISHI SEMICONDUCTORS
M63023/024/026/027FP
SPINDLE MOTOR AND 5CH ACTUATOR driver

○ SPINDLE channel

The relationship between the differential Voltage between SPIN and REF and the torque is shown in right Figure. The Voltage gain[GVo] is 1.0 [V/V]. The current gain[Gio] is 2.0[A/V] (at sensing resistor : 0.5 ohm, and $R1=\infty, R2=0\text{ohm}$) in forward torque directions, and the dead zone is from 0mV to 80mV (at $R1=\infty, R2=0\text{ohm}$).

The coil current gain under the reverse torque is the same with in forward torque directions. And the limitation function gets on when the differential Voltage of VM1(12V)~RSP is 0.5V. Therefore current-gain-control and current-limit of this IC is determined with sensing resistor value, and more detail control can be determined with setting a gain-resistor outer this IC as below.

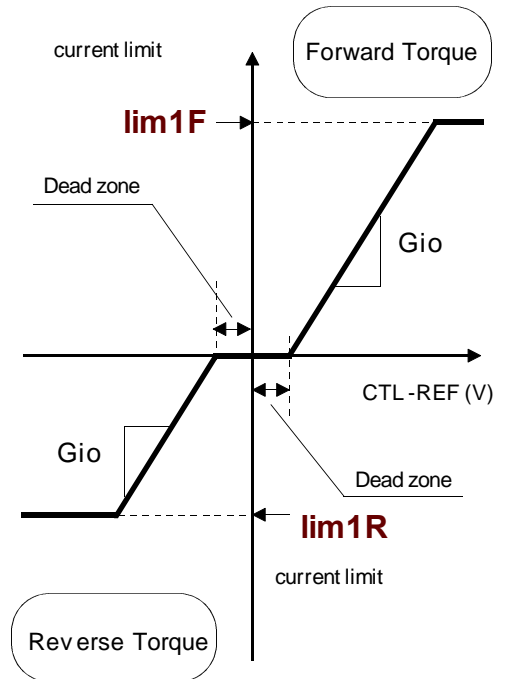

The example of current-gain and current-limit of SPINDLE.

Rs [ohm]	Ilim1F [A]	Ilim1R [A]	Gio* [A/V]		
			R1= ∞ R2=0 ohm	R1=R2	R2=2XR1
0.50	1.00	0.56	2.00	1.00	0.66
0.75	0.66	0.37	1.33	0.66	0.44
1.00	0.50	0.28	1.00	0.50	0.33

$$Gio^* = R1 / [(R1+R2)XR_s] \text{ [A/V]}$$

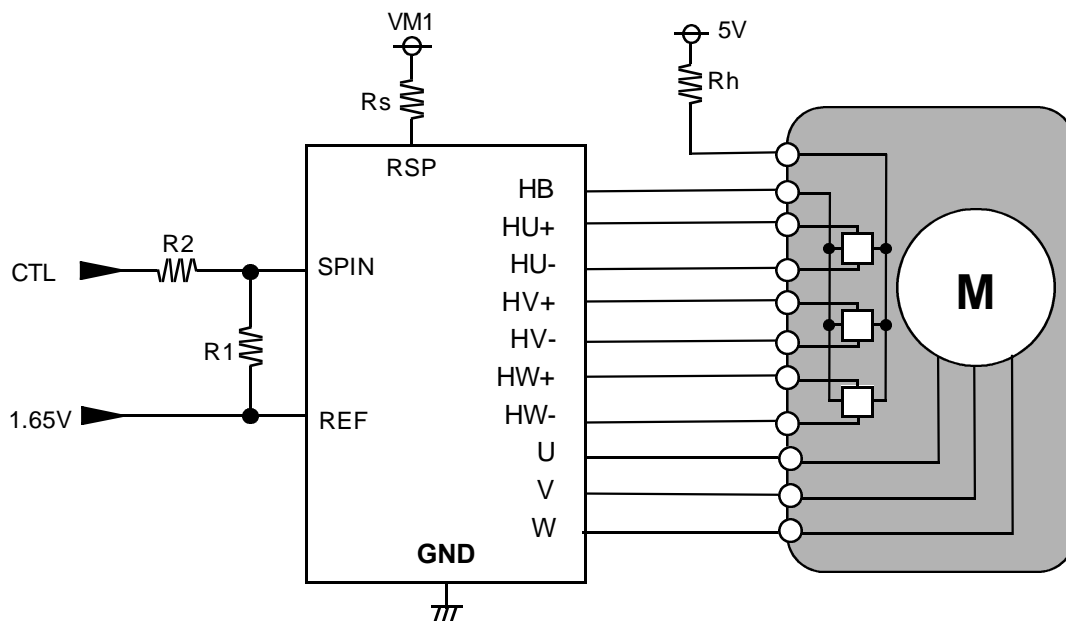

OSLIDE channel

The relationship between the differential Voltage between SLIN and REF and the torque is shown in right Figure. The Voltage gain[GVo] is 1.0 [V/V]. The current gain is 2.0[A/V] (at sensing resistor : 0.5 ohm and $R1=\infty, R2=0\text{ohm}$) in forward torque directions, and the dead zone is from 0mV to 80mV (at $R1=\infty, R2=0\text{ohm}$).

The coil current gain under the reverse torque is the same with in forward torque directions. And the limitation function gets on when the differential Voltage of VM2(12V) ~RSL is 0.5V. Therefore current-gain-control and current-limit of this IC is determined with sensing resistor value.

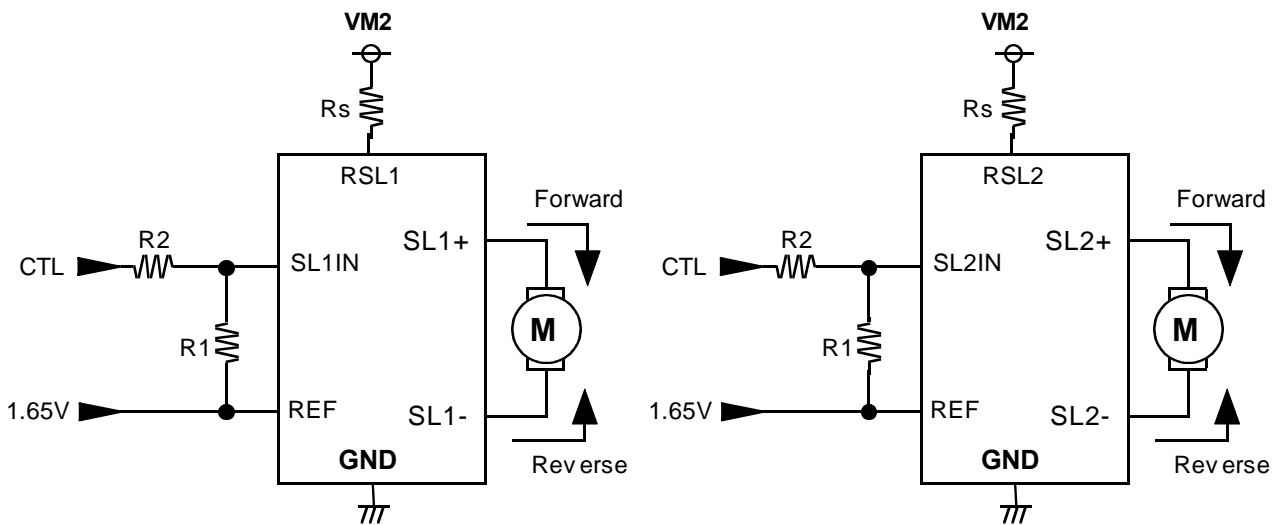
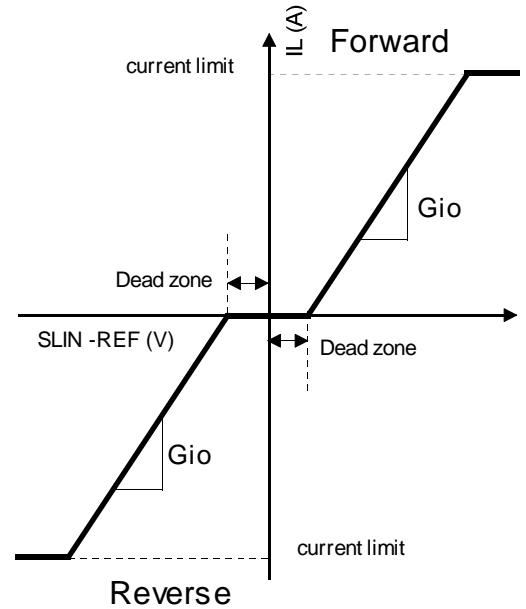

The example of current-gain and current-limit of SLIDE.

Rs [ohm]	Ilim [A]	Gio* [A/V]		
		R1=∞ R2=0 ohm	R1=R2	R2=2XR1
0.50	1.00	2.00	1.00	0.66
0.75	0.66	1.33	0.66	0.44
1.00	0.50	1.00	0.50	0.33

$$G_{io}^* = R1 / [(R1+R2) \times R_s] \quad [A/V]$$

MITSUBISHI SEMICONDUCTORS
M63023/024/026/027FP
SPINDLE MOTOR AND 5CH ACTUATOR driver

○FOCUS / TRACKING channel

The focus and tracking channel is the Voltage control drive using BTL .

The focus and tracking is the same composition.

The relationship between the differential Voltage between FOIN and REF and the output Voltage is shown in below Figure.

The Voltage gain [GVo] is 5.0 [V/V].(M63023/024FP)

The Voltage gain [GVo] is 12.0 [V/V].(M63026/027FP)

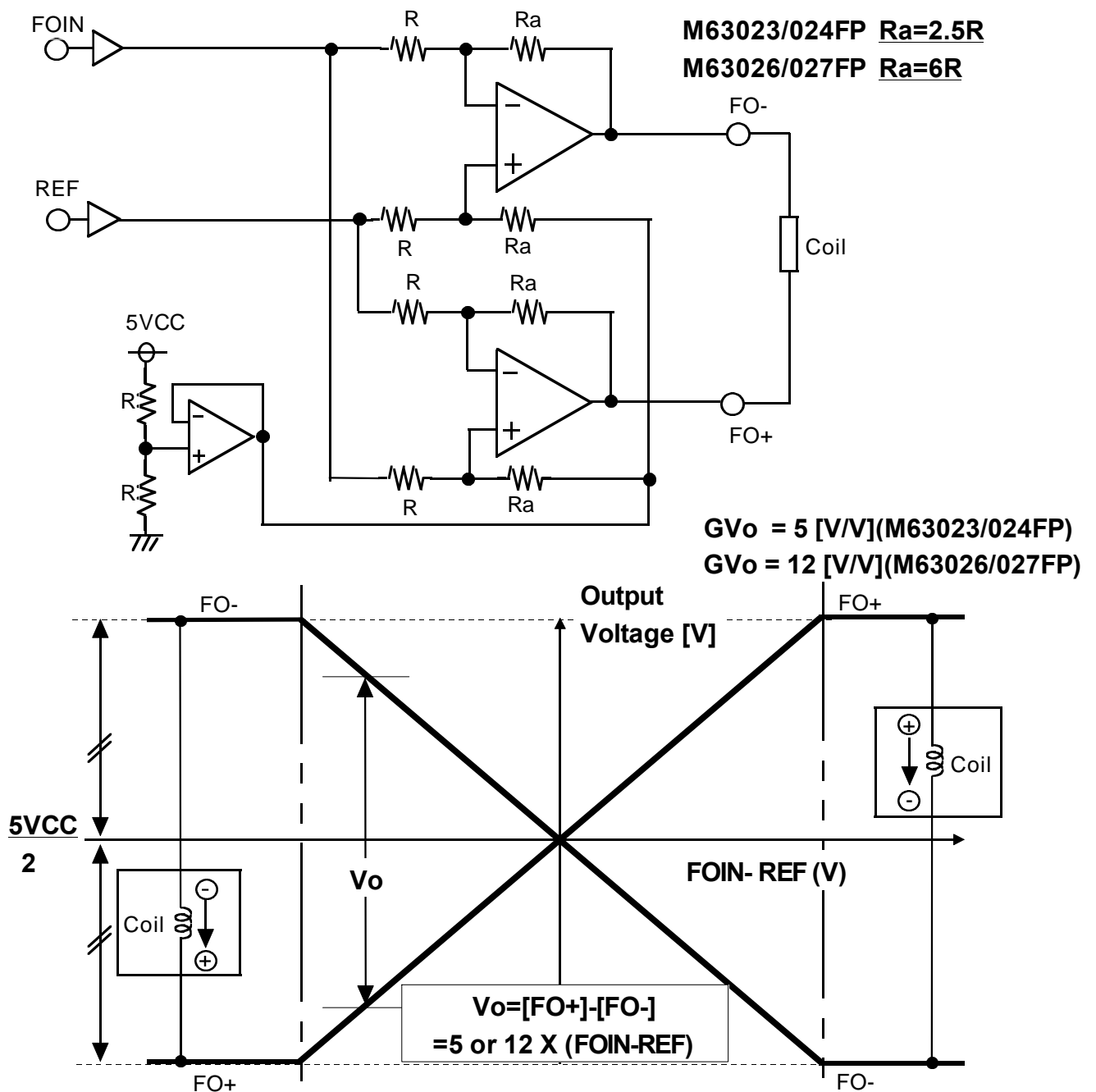

○Direct PWM operation

The spindle and the slide channel is controlled by the direct PWM control. Analog input voltage control the driving current which is in proportion to input voltage. This control is direct PWM control type of motor current chopper. Also, built-in the current limit circuit. This IC controls the motor current directly. direct PWM operation as follows;

- 1) The current which flows on a motor is detected, and current is supplied from a power supply until it reaches the predetermined instruction value to which the current is proportional to input voltage.
- 2) When current reaches an instruction value, an output transistor is changed and the period coil inertia energy to a career cycle is made to regeneration using an internal path.
- 3) After repeat 1) and 2).

Therefore, the IC constantly surveillance and control the current value itself use sensor resistor. Moreover, these ICs built-in current limit circuit so that protect to large current. Thus, if input excessive control voltage, the current don't flow that settle limit current.

FORWARD Current path timing 1.

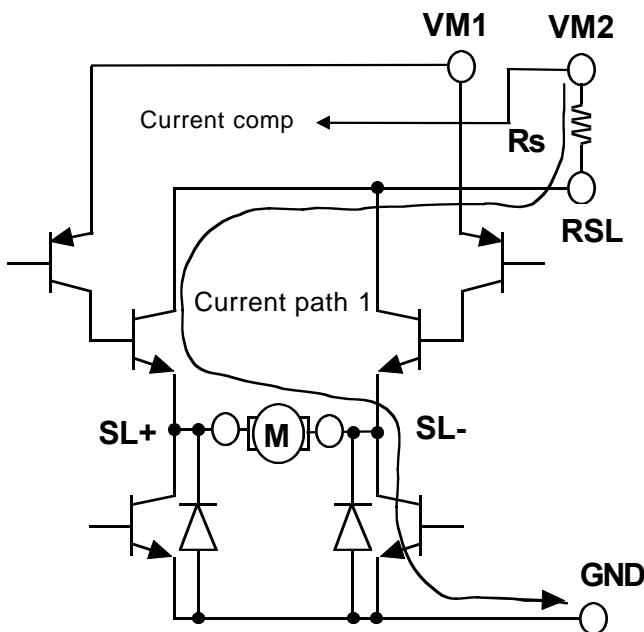

FORWARD Current path timing 2.

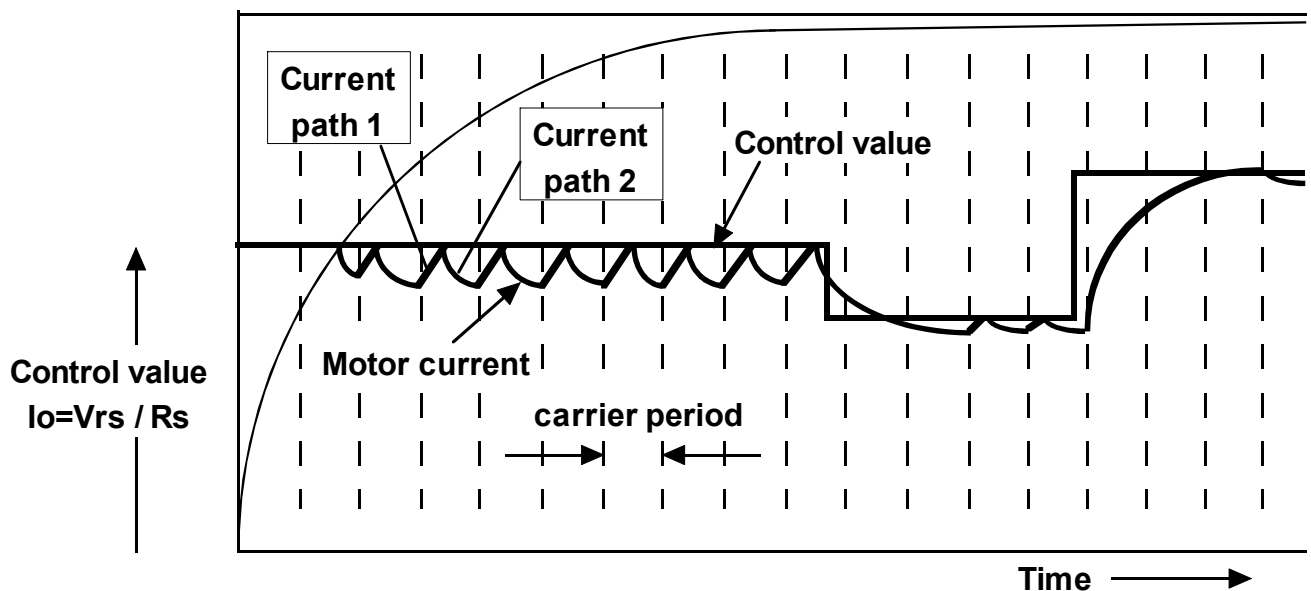
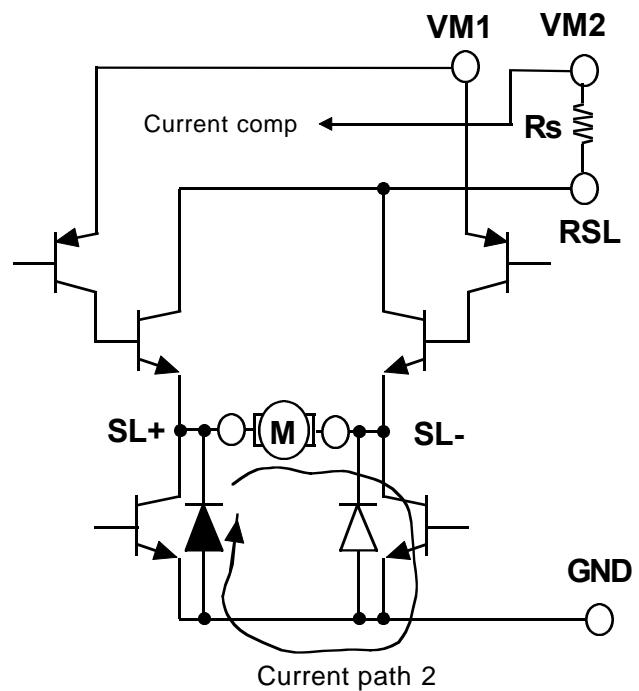

○ PWM carrier frequency setting

PWM carrier frequency is decided by charging and discharging the capacitor that is connected to OSC terminal outer IC. Examination of the relationship the capacitor connected to OSC terminal and PWM carrier frequency is given in following table.

Capacitor [pF]	820	750	330	220	180	130	110
Carrier Frequency [KHz]	28	30	65	90	110	140	160

*note) This PWM carrier frequency is TYP value.

○ Recommendation of SHORT BRAKE MODE at SPINDLE drive

This IC has two brake mode, PWM-BRAKE-MODE and SHORT-BRAKE-MODE. In this IC recommendation, SHORT-BRAKE-MODE is superior to PWM-BRAKE-MODE to reducing the power dissipation and to avoid braking down of this IC.

(By excessive reverse torque current in braking a motor with PWM-BRAKE from high-speed-rotation with being excessive Back-EMF, this IC could be broken.)

○ The relationship between hall-amplifier-input and output-current-commutation/FG output at SPINDLE drive

The relationship between the hall elements and the motor output current/FG output is shown in bellow Figure.

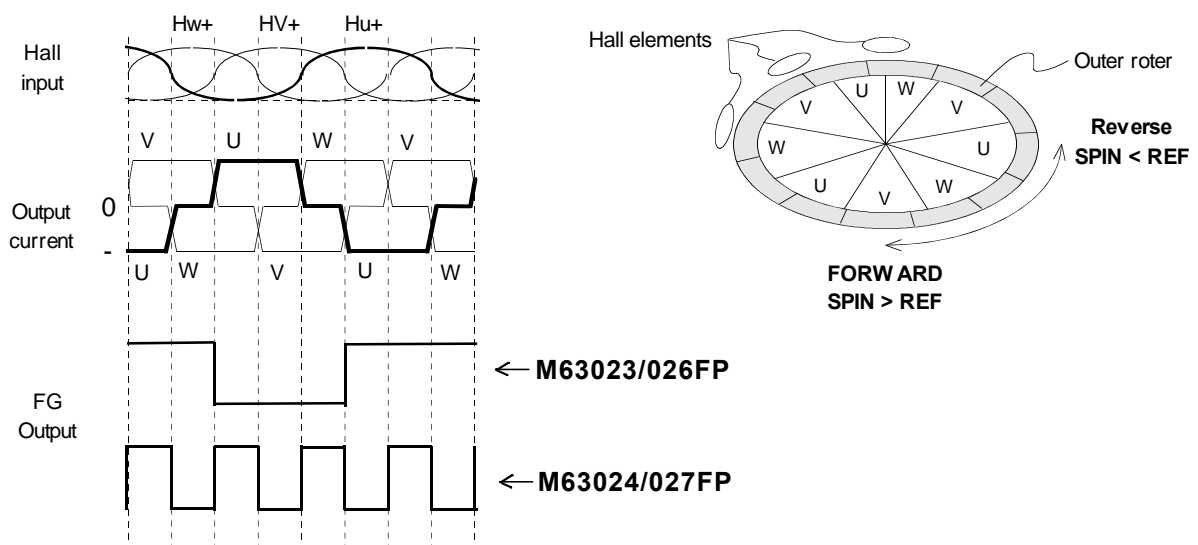

○FG function at SPINDLE drive

The FG terminal outputs the square pulse signal synchronizing with the Hall inputs timing.
And, the FG terminal is open-collector output.

○Phase delay circuit at SLIDE

Phase delay circuit is built in the IC to detect an output spike current, when the motor current direction is switching.

In switching the motor current direction, Phase delay circuit switch-off all output transistor of H-bridge for 3usec.

○Output current setting at SLIDE

In this IC, since output transistor is NPN-type transistor, motor coil current (I_o) is larger than sensing resistance current about 10mA (TYP.) according to base current of output transistor. Therefore please design output current with considering these base current.

MITSUBISHI SEMICONDUCTORS
M63023/024/026/027FP
SPINDLE MOTOR AND 5CH ACTUATOR driver

<I/O circuit>

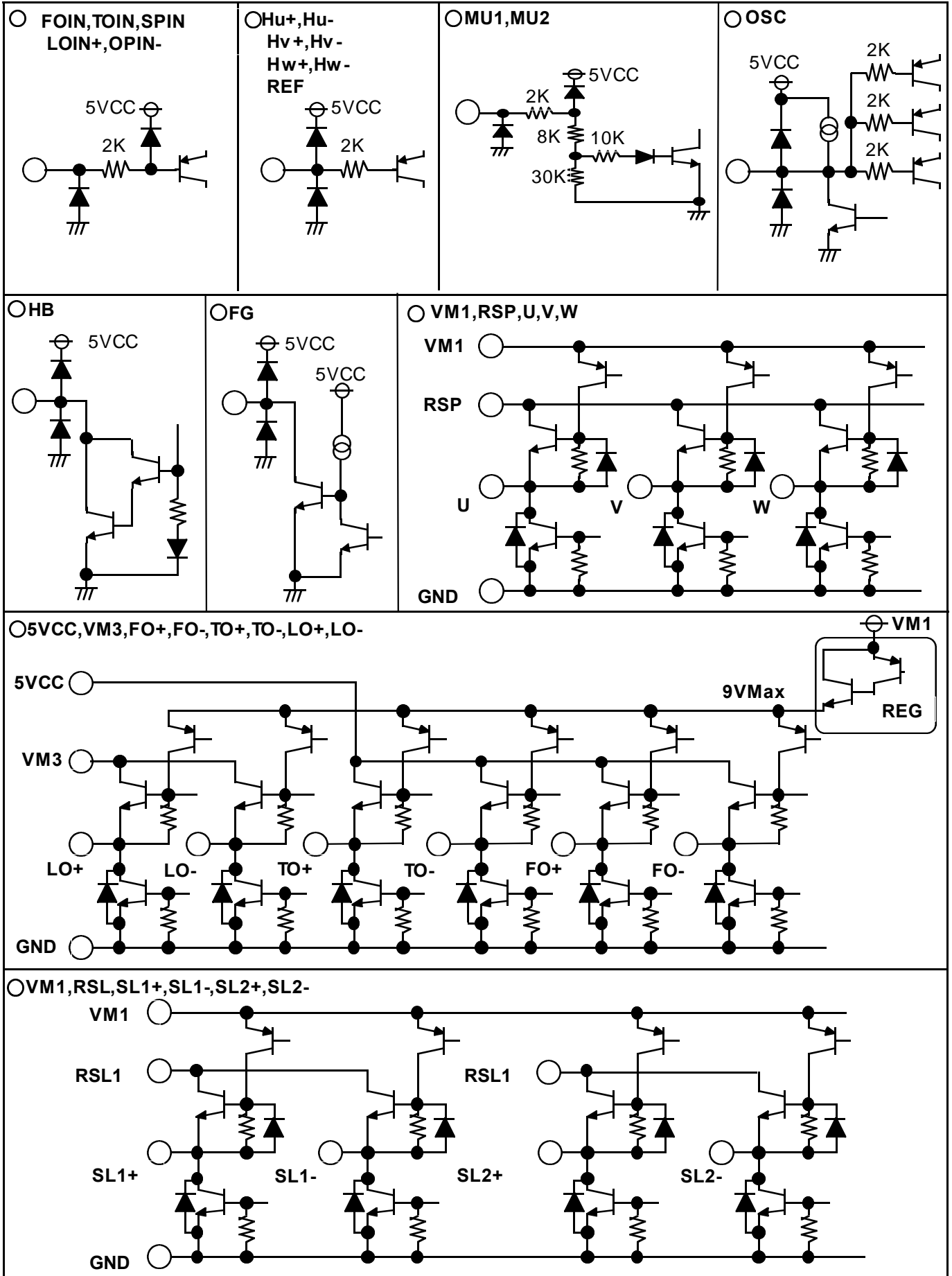

MITSUBISHI SEMICONDUCTORS
M63023/024/026/027FP
SPINDLE MOTOR AND 5CH ACTUATOR driver

[The boards for thermal derating evaluation]

Board material
 Glass - epoxy FR-4

Board Size
 70 X 70mm

Board thickness
 :T=1.6mm

1 and 2 layers
 material : copper
 thickness :T=18um

1st layer [TOP View]

2nd layer [BACK View]

N-type board

[2 layer]

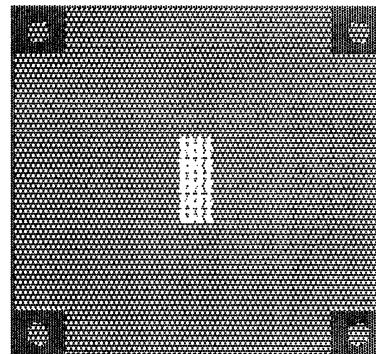
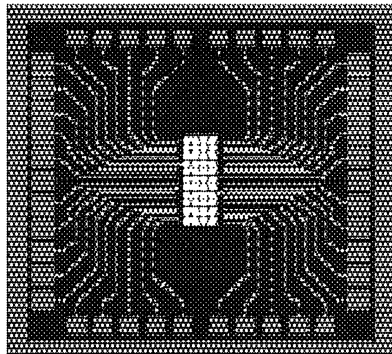

O-type board

[2 layer]

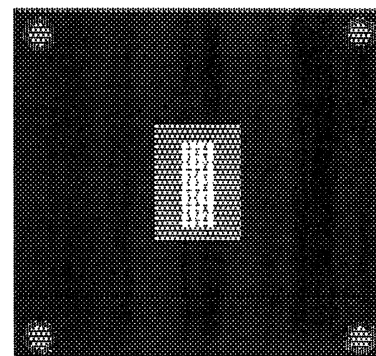
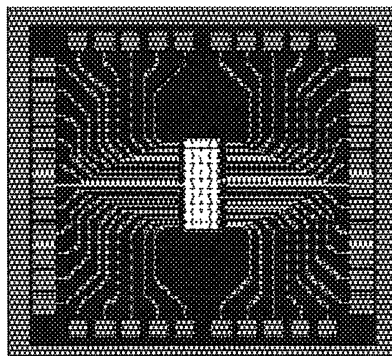

P-type board

[1 layer]

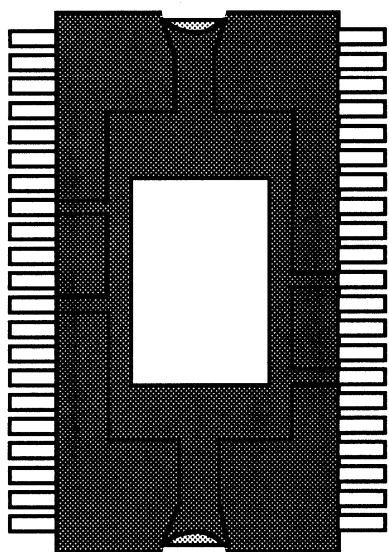
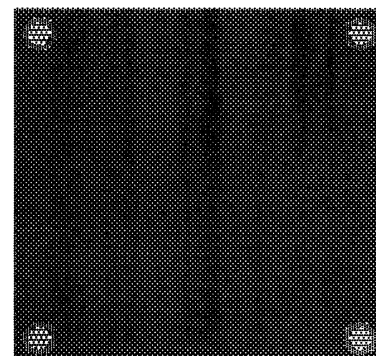
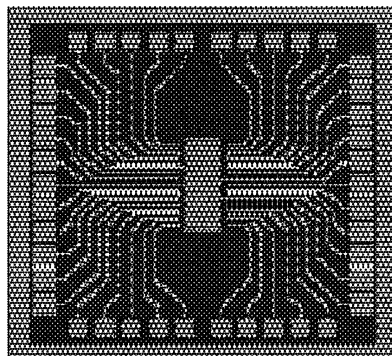

POWER-SSOP 42P9R-K

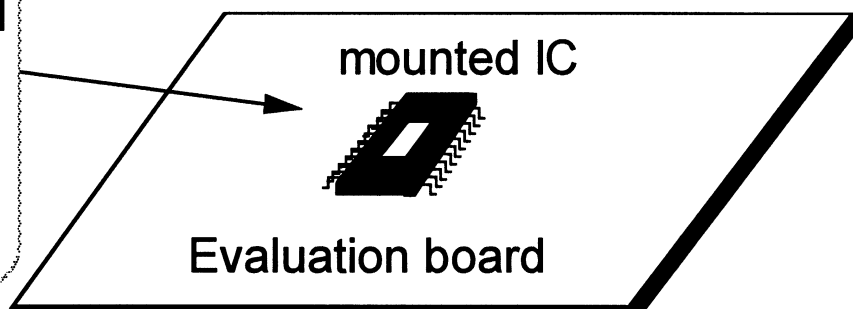
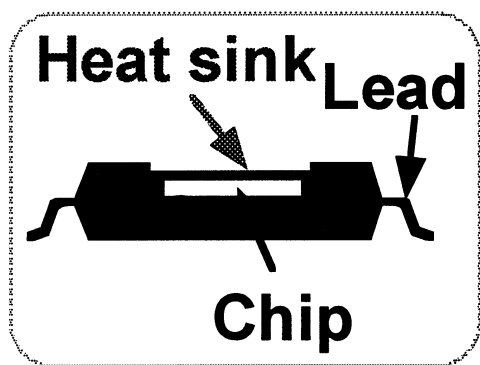

MITSUBISHI SEMICONDUCTORS
M63023/024/026/027FP
 SPINDLE MOTOR AND 5CH ACTUATOR driver

[APPLICATION CIRCUIT no.1]

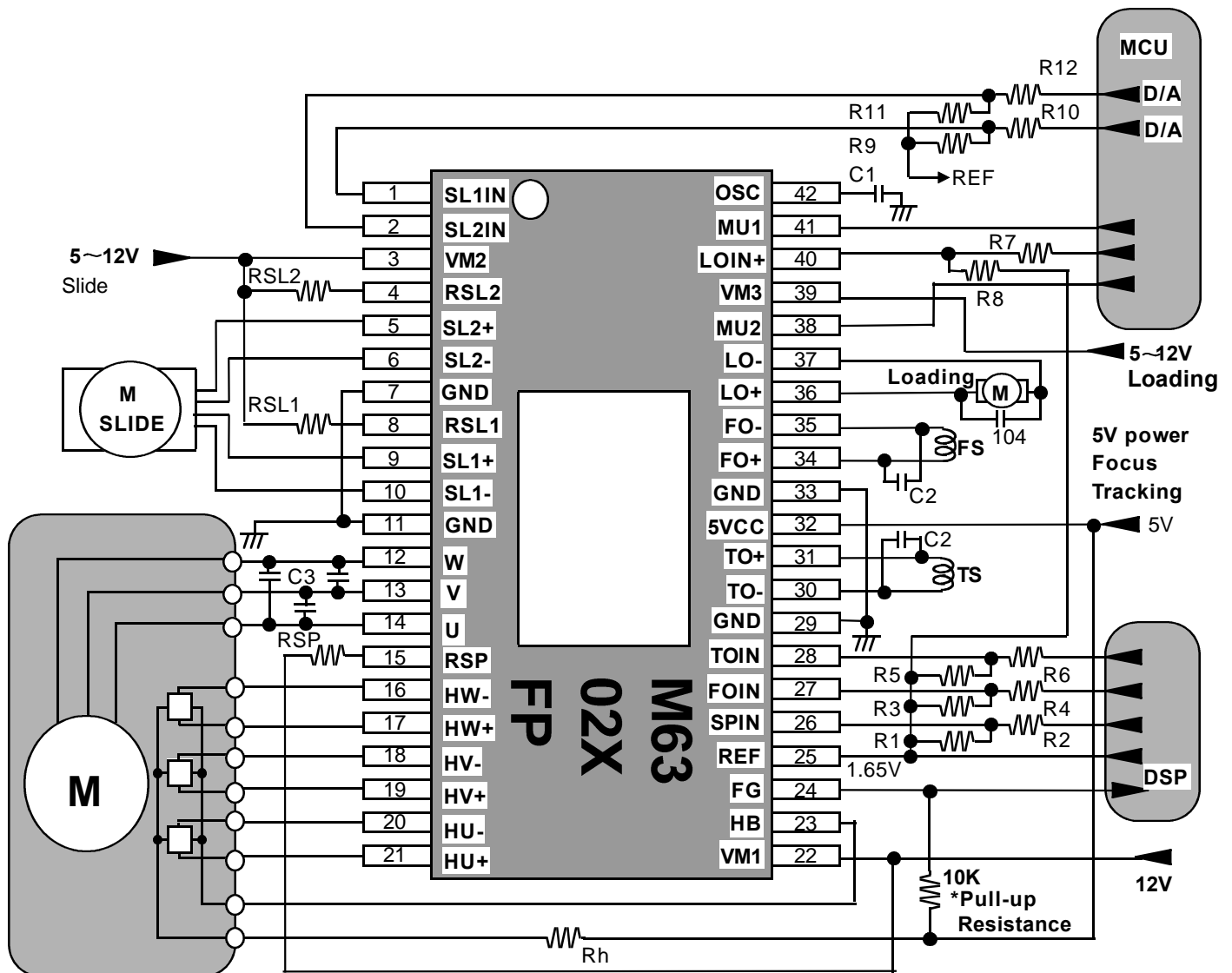

[An example of the values of the external parts]

*These values are only example, not the guaranteed values. And the values differ in each application.

External Parts Name	Typ. value	UNIT	note
RSP	0.33	ohm	Ilim1F=1.5A, Ilim1R=1.0A, Gain=3.0A/V
RSL1, RSL2	2	ohm	Ilim=0.25A, Gain=0.5A/V
Rh	200	ohm	
R1, R2, R3, R4, R5, R6	10K	ohm	The Resistor are not necessary in some application.
R7, R8	10K	ohm	The Resistor are not necessary in some application.
C1	330p	F	Fosc=65KHz
R9, R10, R11, R12	10K	ohm	The Resistor are not necessary in some application.
C2	10n	F	
C3	6.8n	F	

This datasheet has been download from:

www.datasheetcatalog.com

Datasheets for electronics components.