



AC Timer

DESCRIPTION

The AC timer for a fix timer to driver external RELAY to implement safety power control. It is applied to 120V/50Hz and 240V/60Hz AC power supply. It can automatically shut-off load in order to prevent undesired conditions from system. Internal timer can present several kinds of different time.

FEATURE

- Auto-shut off output once time-out
- Button to ON/OFF/RESET timer
- Available timer with high precision same as AC 50/60 Hz
- Drive external RELAY
- Auto detect 50/60Hz
- Quick Test Mode (QTM) for manufacturer
- Available timer of 15/30/45/60/90/120/240/480 min
- SOP-8 Package

APPLICATIONS

- Universal Timer Controller

PIN ASSIGNMENT

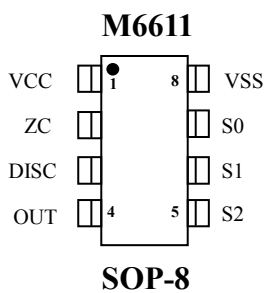



TIMER
M6611

AC Timer

ABSOLUTE MAXIMUM RATING

(TA=25°C)

Parameter	Sym.	Rating	Unit
Power Supply V _{DD} With Respect to V _{SS}	V _{DD} - V _{SS}	1.5	V
Operating Temperature	Top	-20 to 70	°C
Storage Temperature		-65 to 150	°C

ELECTRICAL CHARACTERISTICS

Characteristics	Sym.	Min.	Typ.	Max.	Unit	REMARKS
Operating Voltage	V _{DD}	4.4	4.7	5	V	
Operating Current	I _{OP}	—	—	80	μA	
Quiescent Current	I _{SB}	—	—	0.5	μA	
Oscillator Frequency	F _{OSC}	—	4	—	MHz	Internal oscillator

PIN DEFINITION

Pin No.	Pin name	I/O	Description
1	VCC		Power Supply Pin. Connect a bypass capacitor from this pin to GND
2	ZC	I	Clock input
3	DISC	O	Control output if discharging external capacitor and button input, high active
4	OUT	I/O	RELAY output and button input, high active
5,6,7	S2~S0	I	Timer selection pins(S2 S1 S0 from 000~111) ; internal pull up 000 : 15m , 001 : 30m , 010 : 45m , 011 : 60m , 100 : 90m , 101 : 2 hour ,110 : 4hour ,111 : 8hour
8	VSS		Ground.



TIMER
M6611

AC Timer

FUNCTION DESCRIPTION

ZC

ZC is clock source for internal precise timer. It can auto detect 50Hz or 60Hz

Timer Chain

Timer chain can be used to generate various timer including 15/30/45/60/90/120/240/480min.

Button Sampling

With external buttons, ON/OFF/RESET function can be realized. User can use one button with once ON, once OFF.

If the related button is pressed over 3sec just after power on, chip will enter quick test mode as soon as the button is released.

RELAY Driving Circuit

OUT is active to output 20KHz with 13% duty cycle. When relay is OFF, OUT will output a narrow pulse each 8ms, while, DISC is used to limit the voltage of external high voltage capacitor by discharging it with a NPN transistor, DISC is active to output high level.

Quick Test Mode(QTM)

In order to make the manufacturer's test convenient, quick test mode is designed to speed up the test.

QTM can be accessed by pressing button over 3sec once power on. It can exit automatically after quick test timer is expired, after quick test mode. Any button operations will be ignored in QTM.

Real timer and QTM timer

S2	S1	S0	實際定時	QTM 定時
0	0	0	15 min	2 sec
0	0	1	30 min	4 sec
0	1	0	45 min	6 sec
0	1	1	1 hour	8 sec
1	0	0	1.5 hour	10 sec
1	0	1	2 hour	12 sec
1	1	0	4 hour	14 sec
1	1	1	8 hour	16 sec



TIMER
M6611

AC Timer

APPLICATION CIRCUIT

120V APPLICATION DIAGRAM

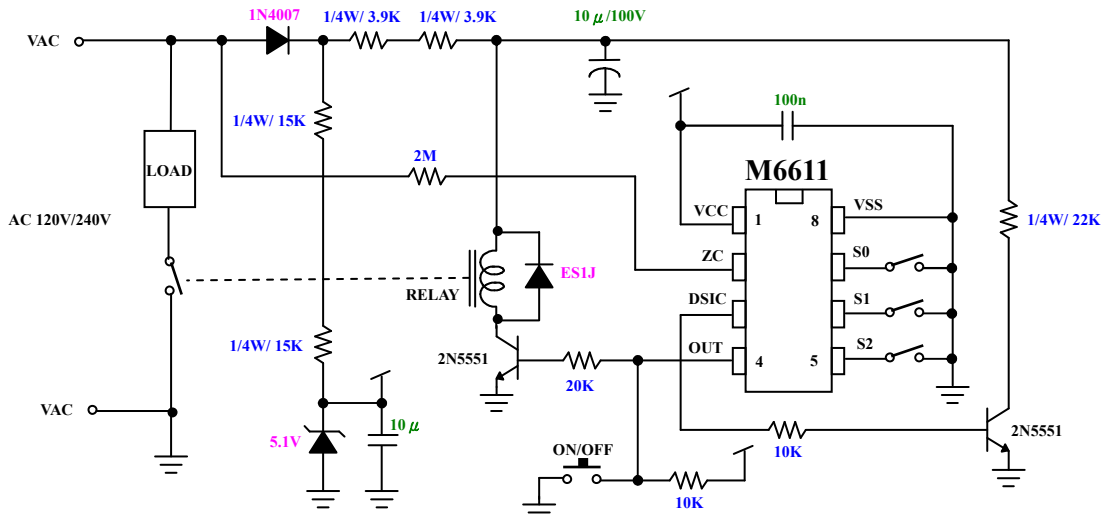

240V APPLICATION DIAGRAM

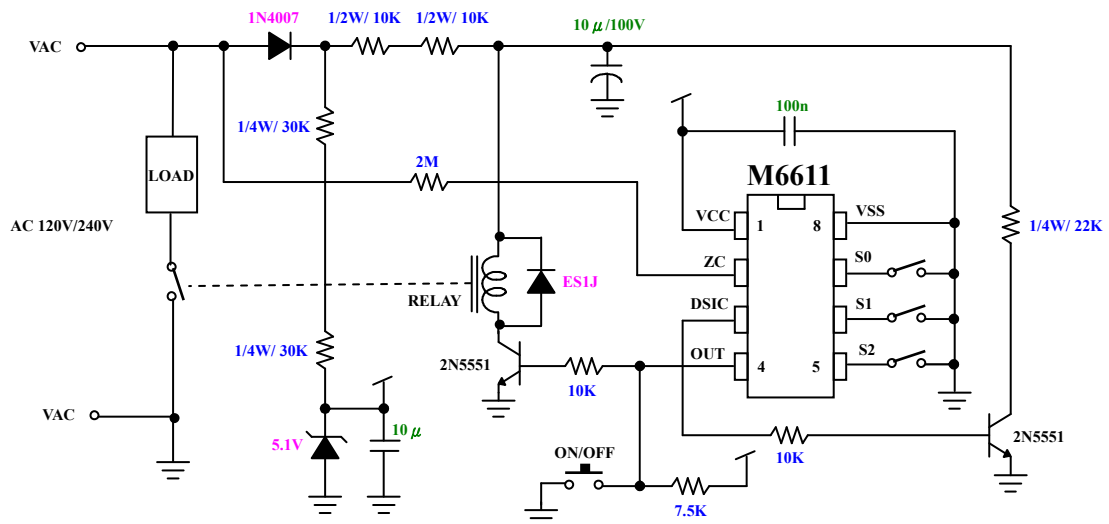



TIMER
M6611

AC Timer

PACKAGE OUTLINE

SYMBOLS	MIN	MAX
A	0.053	0.069
A1	0.004	0.010
A2		0.059
D	0.189	0.196
E	0.150	0.157
H	0.228	0.244
L	0.016	0.050
θ	0	8

Unit : INCH

SOP-8

* All specs and applications shown above subject to change without prior notice.
(以上電路及規格僅供參考,本公司得逕行修正)