



3.5Ω/7Ω Quad SPST Switches with Over-Rail Signal Handling

MAX4851/MAX4851H/MAX4853/MAX4853H

General Description

The MAX4851/MAX4851H/MAX4853/MAX4853H family of quad single-pole/single-throw (SPST) switches operates from a single +2V to +5.5V supply and can handle signals greater than the supply rail. These switches feature low 3.5Ω on-resistance with 40pF on-capacitance or 7Ω on-resistance with 30pF on-capacitance, making them ideal for switching audio and data signals.

The MAX4851/MAX4851H are configured with four SPST switches and feature a comparator for headphone detection or mute/send key functions. The MAX4853/MAX4853H have four SPST switches but do not include a comparator.

For over-rail applications, these devices offer either the pass-through or high-impedance option. For the MAX4851/ MAX4853, signals greater than the positive supply (up to 5.5V) pass through the switch without distortion. For the MAX4851H/MAX4853H, the switch input becomes high impedance when the input signal exceeds the supply rail.

The MAX4851/MAX4851H/MAX4853/MAX4853H are available in the space-saving, 16-pin, 3mm x 3mm thin QFN package and operate over the -40°C to +85°C extended temperature range.

Applications

- USB Switching
- Audio Signal Routing
- Cellular Phones
- Notebook Computers
- PDA's and Other Handheld Devices

Pin Configurations and Typical Operating Circuit appear at end of data sheet

Features

- ◆ USB 2.0 Full Speed (12Mbps) and USB 1.1 Signal Switching
- ◆ Switch Signals Greater than VCC
- ◆ +2V to +5.5V Supply Range
- ◆ 3.5Ω/7Ω On-Resistance
- ◆ 30pF On-Capacitance (7Ω Switch)
- ◆ 150MHz -3dB Bandwidth
- ◆ 1.8V Logic Compatibility
- ◆ Low Supply Current
0.01μA (MAX4853)
5μA (MAX4851)
10μA (MAX4851H/MAX4853H)
- ◆ Low 0.01nA Leakage Current
- ◆ Available in a Space-Saving 3mm x 3mm, 16-Pin TQFN Package

Ordering Information

PART	TEMP RANGE	PIN-PACKAGE	TOP MARK
MAX4851ETE	-40°C to +85°C	16 TQFN-EP*	ABW
MAX4851HETE	-40°C to +85°C	16 TQFN-EP*	ABX
MAX4853ETE	-40°C to +85°C	16 TQFN-EP*	ACB
MAX4853HETE	-40°C to +85°C	16 TQFN-EP*	ACC

*EP = Exposed paddle.

Block Diagram/Truth Table

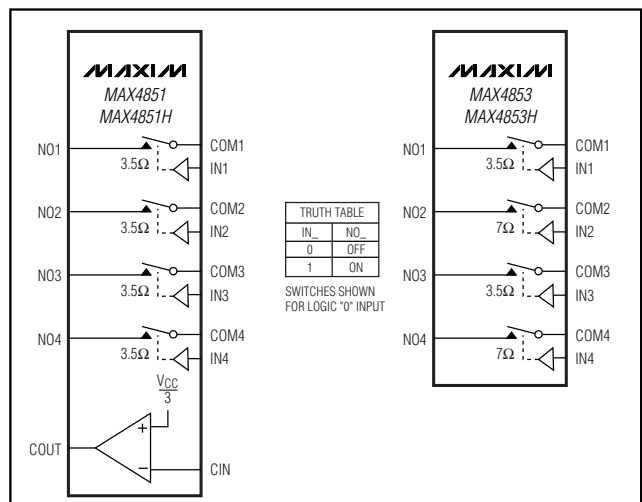

3.5Ω/7Ω Quad SPST Switches with Over-Rail Signal Handling

ABSOLUTE MAXIMUM RATINGS

V _{CC} , IN ₋ , CIN, COM ₋ , NO ₋ to GND (Note 1)-0.3V to +6.0V
CO _{UT}-0.3V to (V _{CC} + 0.3V)
CO _{UT} Continuous Current±20mA
Closed-Switch Continuous Current COM ₋ , NO ₋ , NC ₋	
3.5Ω Switch±100mA
7Ω Switch±50mA
Peak Current COM ₋ , NO ₋ (pulsed at 1ms, 50% duty cycle)	
3.5Ω Switch±200mA
7Ω Switch±100mA

Peak Current COM ₋ , NO ₋ (pulsed at 1ms, 10% duty cycle)	
3.5Ω Switch±240mA
7Ω Switch±120mA
Continuous Power Dissipation (T _A = +70°C)	
16-Pin Thin QFN (derate 20.8mW/°C above +70°C)	...1667mW
Operating Temperature Range-40°C to +85°C
Junction Temperature+150°C
Storage Temperature Range-65°C to +150°C
Lead Temperature (soldering, 10s)+300°C

Note 1: Signals on IN₋, NO₋, or COM₋ below GND are clamped by internal diodes. Limit forward-diode current to maximum current rating.

Stresses beyond those listed under "Absolute Maximum Ratings" may cause permanent damage to the device. These are stress ratings only, and functional operation of the device at these or any other conditions beyond those indicated in the operational sections of the specifications is not implied. Exposure to absolute maximum rating conditions for extended periods may affect device reliability.

ELECTRICAL CHARACTERISTICS

(V_{CC} = +2.7V to +5.5V, T_A = -40°C to +85°C, unless otherwise noted. Typical values are at V_{CC} = +3.0V, T_A = +25°C, unless otherwise noted.) (Note 2)

PARAMETER	SYMBOL	CONDITIONS		MIN	TYP	MAX	UNITS
Supply Voltage	V _{CC}			2.0		5.5	V
Supply Current	I _{CC}	V _{CC} = 5.5V, V _{IN-} = 0 or V _{CC}	MAX4851		5	10	μA
			MAX4851H/MAX4853H		10	20	
			MAX4853		0.01	1	
ANALOG SWITCH (3.5Ω Switch)							
Analog Signal Range	V _{NO-} , V _{COM-}			0		5.5	V
On-Resistance	R _{ON}	V _{CC} = 3V, I _{COM-} = 10mA, V _{NO-} = 0 to 5.5V (MAX485-) or V _{CC} (MAX485-H)	T _A = +25°C		3.5	4.5	Ω
			T _A = -40°C to +85°C			5	
On-Resistance Match Between Channels (Notes 3, 4)	ΔR _{ON}	V _{CC} = 3V; I _{COM-} = 10mA; V _{NO-} = 1.5V	T _A = +25°C		0.1	0.2	Ω
			T _A = -40°C to +85°C			0.25	
On-Resistance Flatness (Note 5)	R _{FLAT}	V _{CC} = 3V, I _{COM-} = 10mA, V _{NO-} = 1V, 2V, 3V	T _A = +25°C		1.2	1.8	Ω
			T _A = -40°C to +85°C			2	
NO ₋ Off-Leakage Current	I _{OFF}	V _{CC} = 5.5V, V _{NO-} = 1V or 4.5V, V _{COM-} = 4.5V or 1V	T _A = +25°C		-2	+2	nA
			T _A = -40°C to +85°C		-10	+10	
COM ₋ On-Leakage Current	I _{ON}	V _{CC} = 5.5V; V _{NO-} = 1V, 4.5V, or floating; V _{COM-} = 1V, 4.5V, or floating	T _A = +25°C		-2	+2	nA
			T _A = -40°C to +85°C		-12.5	+12.5	
-3dB Bandwidth	BW	Signal = 0dBm, R _L = 50Ω, C _L = 5pF, Figure 4			135		MHz

Quad SPST Switches with Over-Rail Signal Handling

MAX4851/MAX4851H/MAX4853/MAX4853H

ELECTRICAL CHARACTERISTICS (continued)

($V_{CC} = +2.7V$ to $+5.5V$, $T_A = -40^{\circ}C$ to $+85^{\circ}C$, unless otherwise noted. Typical values are at $V_{CC} = +3.0V$, $T_A = +25^{\circ}C$, unless otherwise noted.) (Note 2)

PARAMETER	SYMBOL	CONDITIONS	MIN	TYP	MAX	UNITS
NO_ Off-Capacitance	C_{OFF}	$f = 1MHz$, Figure 5		20		pF
COM On-Capacitance	C_{ON}	$f = 1MHz$, Figure 5		40		pF
ANALOG SWITCH (7Ω Switch)						
Analog Signal Range	$V_{NO_}$, $V_{COM_}$		0		5.5	V
On-Resistance	R_{ON}	$V_{CC} = 3V$, $I_{COM_} = 10mA$, $V_{NO_} = 0$ to $5.5V$ (MAX485_) , or V_{CC} (MAX485_H)	$T_A = +25^{\circ}C$	7	9	Ω
			$T_A = -40^{\circ}C$ to $+85^{\circ}C$		10	
On-Resistance Match Between Channels (Notes 3, 4)	ΔR_{ON}	$V_{CC} = 3V$, $I_{COM_} = 10mA$, $V_{NO_} = 1.5V$	$T_A = +25^{\circ}C$	0.2	0.4	Ω
			$T_A = -40^{\circ}C$ to $+85^{\circ}C$		0.5	
On-Resistance Flatness (Note 5)	R_{FLAT}	$V_{CC} = 3V$; $I_{COM_} = 10mA$; $V_{NO_} = 1V$, $2V$, $3V$	$T_A = +25^{\circ}C$	2.5	3.75	Ω
			$T_A = -40^{\circ}C$ to $+85^{\circ}C$		4.0	
NO_ Off-Leakage Current	I_{OFF}	$V_{CC} = 5.5V$, $V_{NO_} = 1V$ or $4.5V$, $V_{COM_} = 4.5V$ or $1V$	$T_A = +25^{\circ}C$	- 2	+2	nA
			$T_A = -40^{\circ}C$ to $+85^{\circ}C$	-10	+10	
COM_ On-Leakage Current	I_{ON}	$V_{CC} = 5.5V$; $V_{NO_} = 1V$, $4.5V$, or floating; $V_{COM_} = 1V$, $4.5V$, or floating	$T_A = +25^{\circ}C$	- 2	+2	nA
			$T_A = -40^{\circ}C$ to $+85^{\circ}C$	- 12.5	+12.5	
-3dB Bandwidth	BW	Signal = 0dBm, $R_L = 50\Omega$, $C_L = 5pF$, Figure 4		150		MHz
NO_ Off-Capacitance	C_{OFF}	$f = 1MHz$, Figure 5		13		pF
COM On-Capacitance	C_{ON}	$f = 1MHz$, Figure 5		30		pF
DYNAMIC CHARACTERISTICS						
Signal Over-Rail to High-Impedance Switching Time	t_{HIZ}	MAX4851H/MAX4853H, $V_{NO_} = V_{CC}$ to $(V_{CC} + 0.5V)$, $V_{CC} < 5V$, Figure 1		0.5	1	μs
High-Impedance to Low-Impedance Switching Time	t_{HIZB}	MAX4851H/MAX4853H, $V_{NO_} = (V_{CC} + 0.5V)$ to V_{CC} , $V_{CC} < 5V$, Figure 1		0.5	1	μs
Skew (Note 3)	t_{SKEW}	$R_S = 39\Omega$, $C_L = 50pF$, Figure 2		0.1	1	ns
Propagation Delay (Note 3)	t_{PD}	$R_S = 39\Omega$, $C_L = 50pF$, Figure 2		0.9	2	ns
Turn-On Time	t_{ON}	$V_{CC} = 3V$, $V_{NO_} = 1.5V$, $R_L = 300\Omega$, $C_L = 50pF$, Figure 1	$T_A = +25^{\circ}C$	40	60	ns
			$T_A = -40^{\circ}C$ to $+85^{\circ}C$		100	
Turn-Off Time	t_{OFF}	$V_{CC} = 3V$, $V_{NO_} = 1.5V$, $R_L = 300\Omega$, $C_L = 50pF$, Figure 1	$T_A = +25^{\circ}C$	30	40	ns
			$T_A = -40^{\circ}C$ to $+85^{\circ}C$		60	
Charge Injection	Q	$V_{COM_} = 1.5V$, $R_S = 0\Omega$, $C_L = 1nF$, Figure 3		8		pC

3.5Ω/7Ω Quad SPST Switches with Over-Rail Signal Handling

ELECTRICAL CHARACTERISTICS (continued)

($V_{CC} = +2.7V$ to $+5.5V$, $T_A = -40^{\circ}C$ to $+85^{\circ}C$, unless otherwise noted. Typical values are at $V_{CC} = +3.0V$, $T_A = +25^{\circ}C$, unless otherwise noted.) (Note 2)

PARAMETER	SYMBOL	CONDITIONS	MIN	TYP	MAX	UNITS
Off-Isolation (Note 6)		$f = 100kHz$, $V_{COM_} = 1V_{RMS}$, $R_L = 50\Omega$, $C_L = 5pF$, Figure 4		-80		dB
Crosstalk		$f = 1MHz$, $V_{COM_} = 1V_{RMS}$, $R_L = 50\Omega$, $C_L = 5pF$, Figure 4		-95		dB
Total Harmonic Distortion	THD	$f = 20Hz$ to $20kHz$, $V_{COM_} = 1V + 2V_{P-P}$, $R_L = 600\Omega$		0.04		%
DIGITAL I/O (IN_)						
Input Logic High Voltage	V_{IH}	$V_{CC} = 2V$ to $3.6V$	1.4			V
		$V_{CC} = 3.6V$ to $5.5V$	1.8			
Input Logic Low Voltage	V_{IL}	$V_{CC} = 2V$ to $3.6V$			0.5	V
		$V_{CC} = 3.6V$ to $5.5V$			0.8	
Input Leakage Current	I_{IN}	$V_{IN_} = 0$ or $5.5V$	-0.5		+0.5	μA
COMPARATOR						
Comparator Range			0		5.5	V
Comparator Threshold	V_{TH}	$V_{CC} = 2V$ to $5.5V$, falling input	$0.3 \times V_{CC}$	$0.33 \times V_{CC}$	$0.36 \times V_{CC}$	V
Comparator Hysteresis		$V_{CC} = 2V$ to $5.5V$		50		mV
Comparator Output High Voltage		$I_{SOURCE} = 1mA$	$V_{CC} - 0.4V$			V
Comparator Output Low Voltage		$I_{SINK} = 1mA$			0.4	V
Comparator Switching Time		Rising input, Figure 6		2.5		μs
		Falling input, Figure 6		0.5		

Note 2: Specifications are 100% tested at $T_A = +85^{\circ}C$ only, and guaranteed by design and characterization over the specified temperature range.

Note 3: Guaranteed by design and characterization; not production tested.

Note 4: $\Delta R_{ON} = R_{ON(MAX)} - R_{ON(MIN)}$.

Note 5: Flatness is defined as the difference between the maximum and minimum value of on-resistance as measured over the specified analog signal ranges.

Note 6: Off-isolation = $20\log_{10}(V_{COM_} / V_{NO_})$, $V_{COM_}$ = output, $V_{NO_}$ = input to off switch.

Quad SPST Switches with Over-Rail Signal Handling

Typical Operating Characteristics

($V_{CC} = 3.0V$, $T_A = +25^\circ C$, unless otherwise noted.)

MAX4851/MAX4851H/MAX4853/MAX4853H

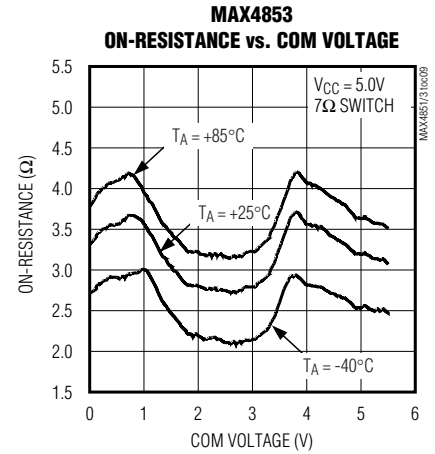
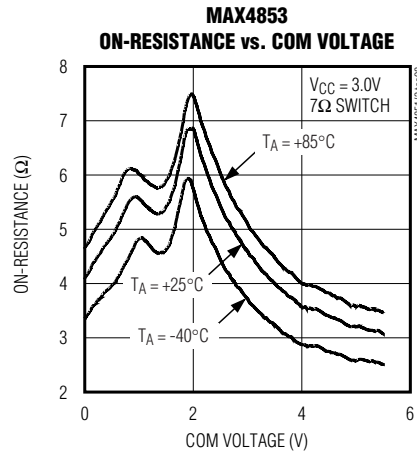
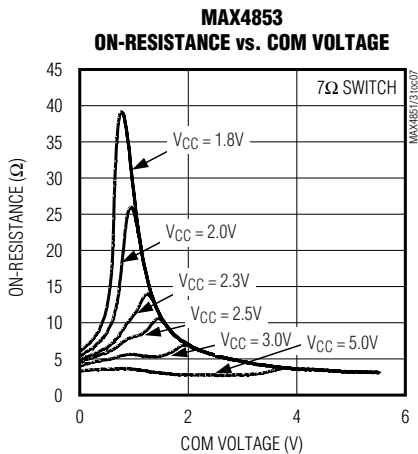
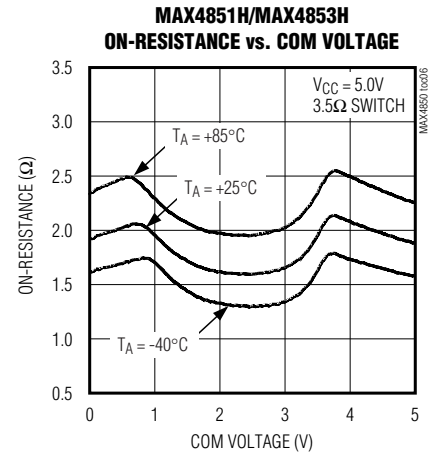
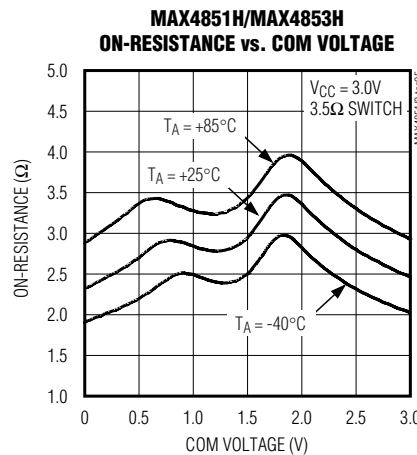
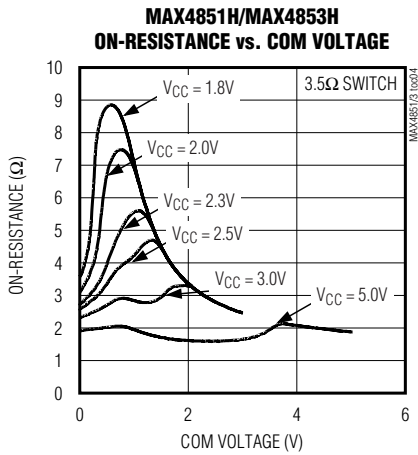
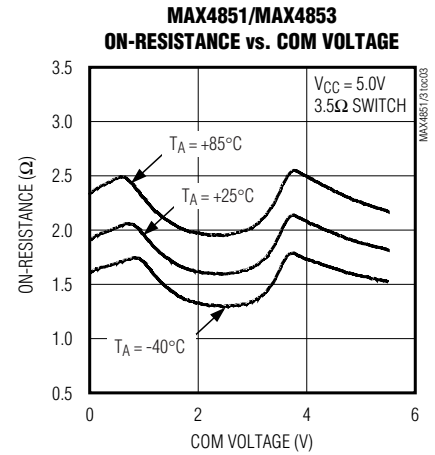
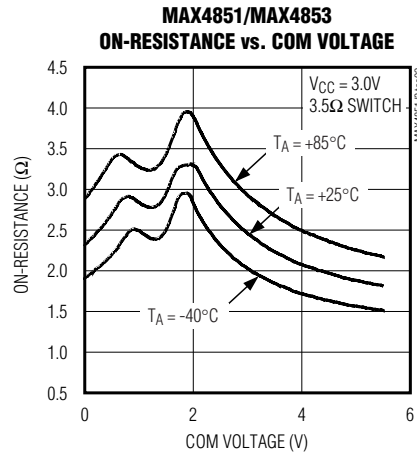
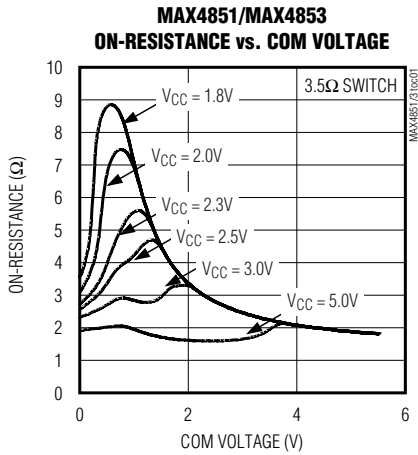

3.5Ω/7Ω Quad SPST Switches with Over-Rail Signal Handling

Typical Operating Characteristics (continued)

(V_{CC} = 3.0V, T_A = +25°C, unless otherwise noted.)

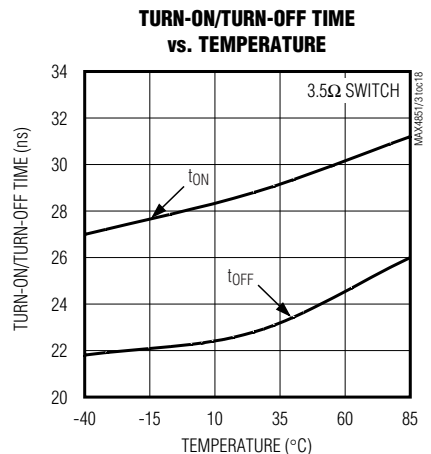
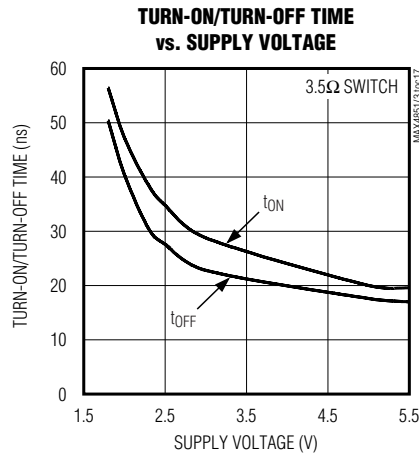
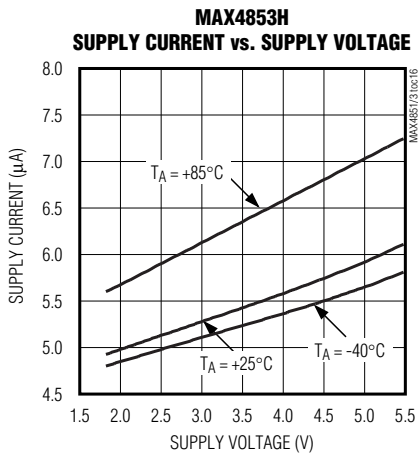
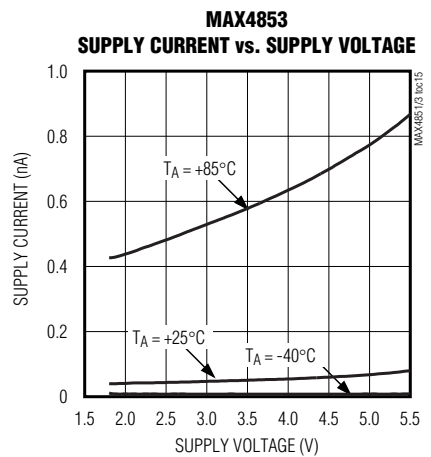
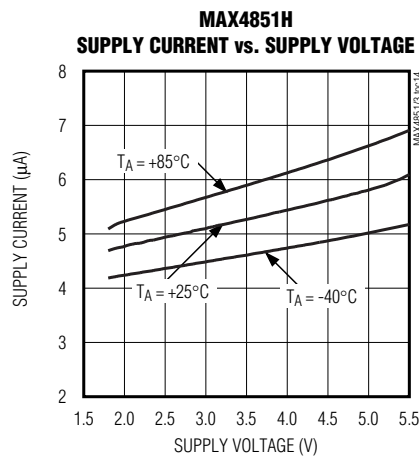
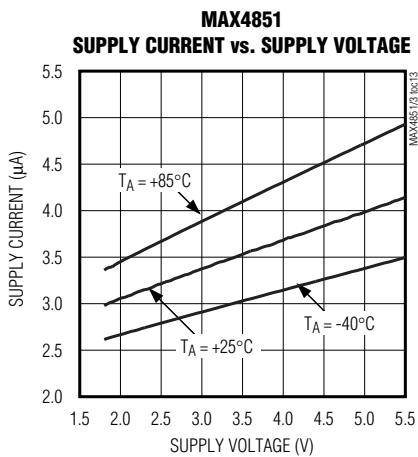
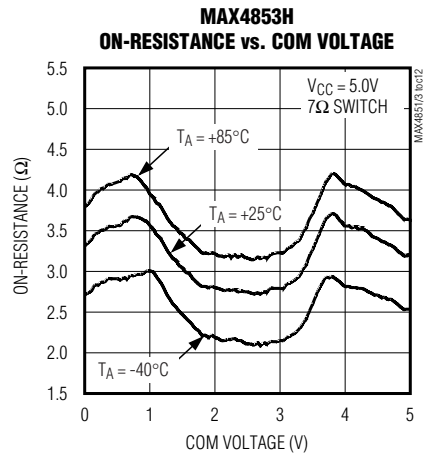
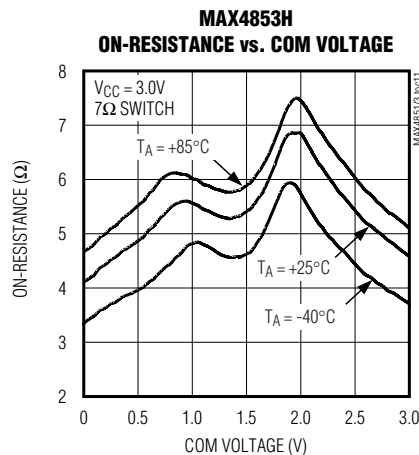
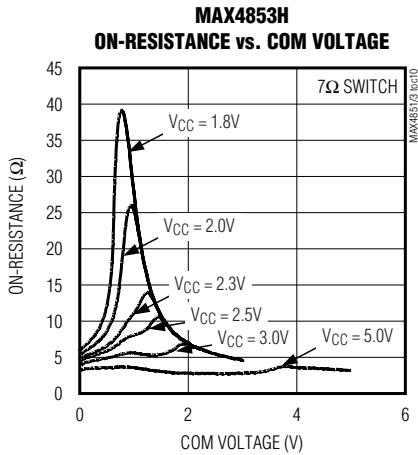

Quad SPST Switches with Over-Rail Signal Handling

Typical Operating Characteristics (continued)

($V_{CC} = 3.0V$, $T_A = +25^\circ C$, unless otherwise noted.)

MAX4851/MAX4851H/MAX4853/MAX4853H

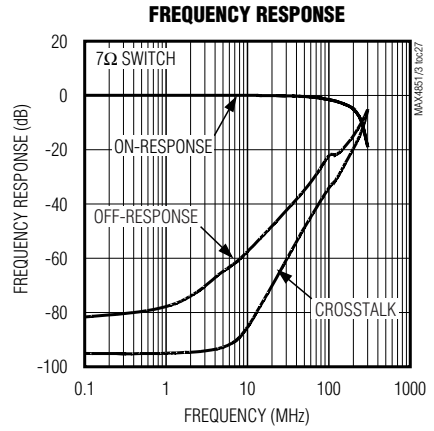
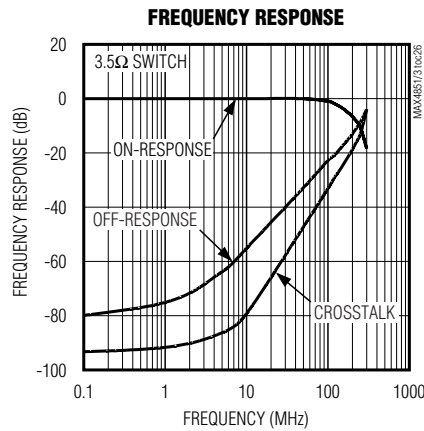
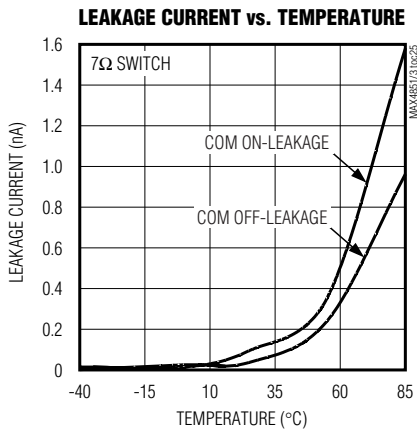
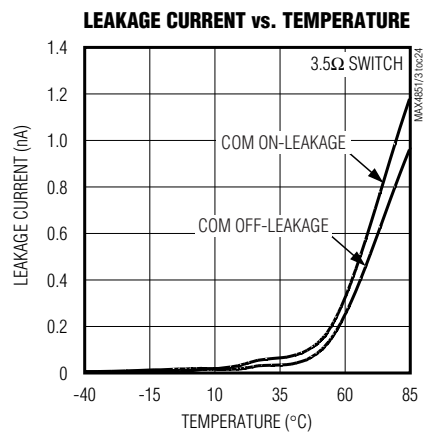
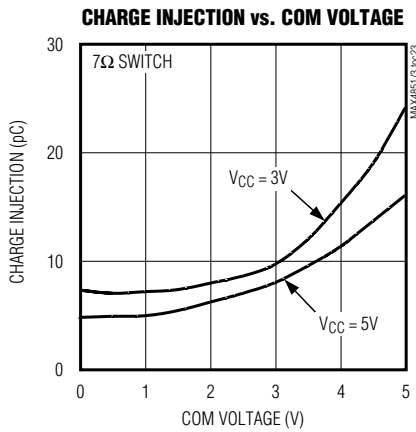
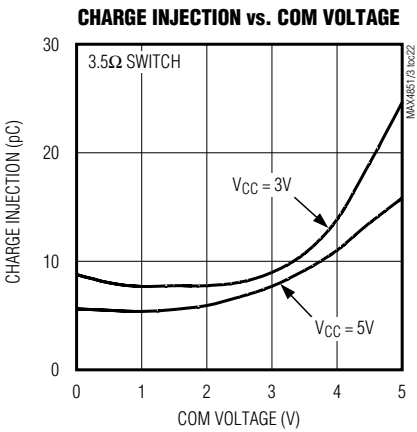
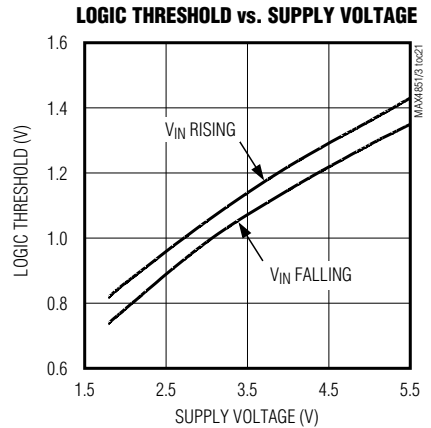
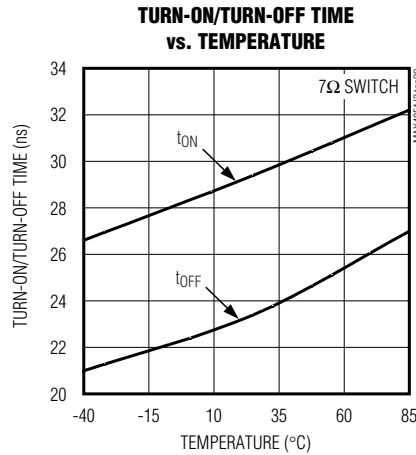
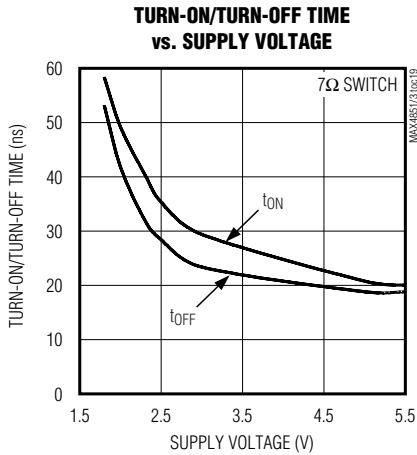

3.5Ω/7Ω Quad SPST Switches with Over-Rail Signal Handling

Typical Operating Characteristics (continued)

(V_{CC} = 3.0V, T_A = +25°C, unless otherwise noted.)

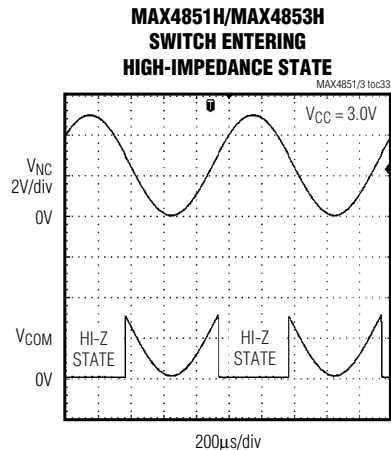
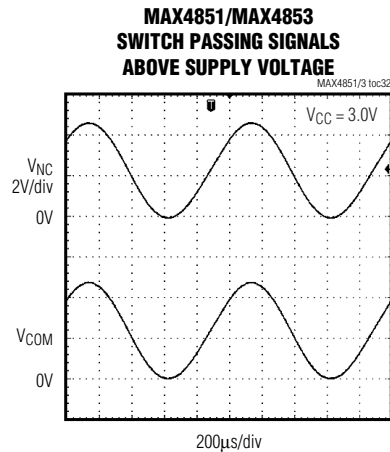
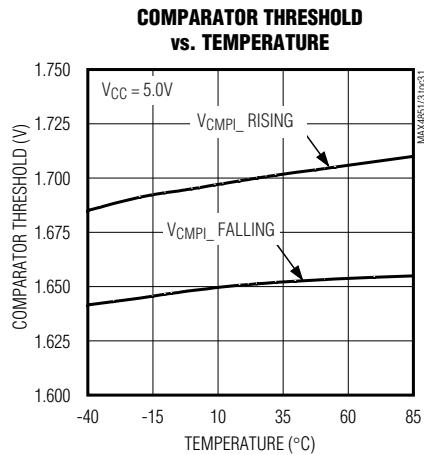
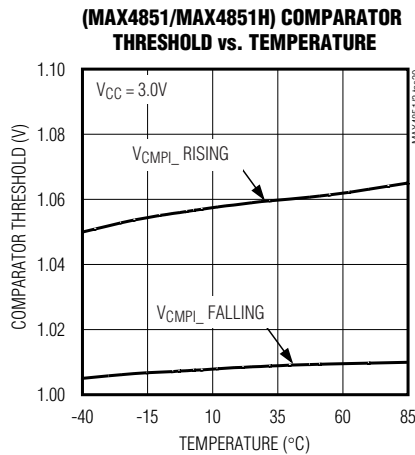
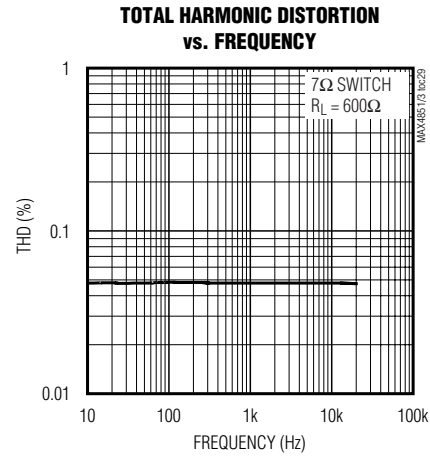
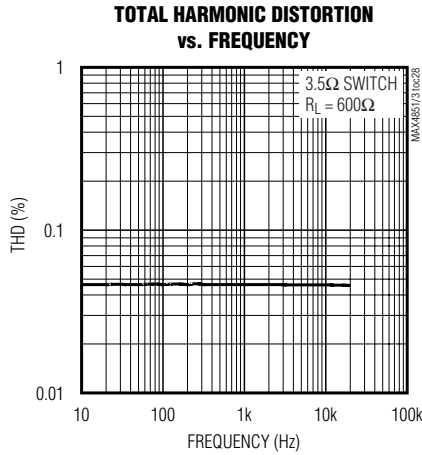

Quad SPST Switches with Over-Rail Signal Handling

Pin Description

PIN		NAME	FUNCTION
MAX4851 MAX4851H	MAX4853 MAX4853H		
1	1	NO1	Normally Open Terminal for Analog Switch 1
2	—	CIN	Inverting Input for Comparator
3	3	IN2	Digital Control Input for Analog Switch 2. A logic-low on IN2 disconnects COM2 from NO2 and a logic-high connects COM2 to NO2.
4	4	COM2	Common Terminal for Analog Switch 2
5	5	NO2	Normally Open Terminal for Analog Switch 2
6	6	GND	Ground
7	7	NO3	Normally Open Terminal for Analog Switch 3
8	8	COM3	Common Terminal for Analog Switch 3
9	9	IN3	Digital Control Input for Analog Switch 3. A logic-low on IN3 disconnects COM3 from NO3 and a logic-high connects COM3 to NO3.
10	10	NO4	Normally Open Terminal for Analog Switch 4
11	—	COU	Output for Comparator
12	12	COM4	Common Terminal for Analog Switch 4
13	13	IN4	Digital Control Input for Analog Switch 4. A logic-low on IN4 disconnects COM4 from NO4 and a logic-high connects COM4 to NO4.
14	14	V _{CC}	Supply Voltage. Bypass to GND with a 0.01μF capacitor as close to the pin as possible.
15	15	IN1	Digital Control Input for Analog Switch 1. A logic-low on IN1 disconnects COM1 from NO1 and a logic-high connects COM1 to NO1.
16	16	COM1	Common Terminal for Analog Switch 1
—	2, 11	N.C.	No Connection. Not internally connected.
EP	EP	GND	Exposed Pad. Connect to ground.

Detailed Description

The MAX4851/MAX4851H/MAX4853/MAX4853H are low on-resistance, low-voltage, analog switches that operate from a +2V to +5.5V single supply and are fully specified for nominal 3.0V applications. The MAX4851/MAX4853 devices feature over-rail signal capability that allows signals up to 5.5V with supply voltages down to 2.0V to pass through without distortion. The MAX4851H/MAX4853H enter high-impedance mode when the signal voltage exceeds V_{CC} and return to normal operation when the signal voltage drops below V_{CC}.

These quad SPST switches have low on-channel capacitance, which allows switching of the data signals for USB 2.0/1.1 applications (12Mbps). They are designed to switch D+ and D- USB signals with a guaranteed skew of less than 1ns (see Figure 2), as measured from 50% of the input signal to 50% of the output signal.

The MAX4851_ features a comparator that can be used for headphone or mute detection. The comparator threshold is internally generated to be approximately 1/3 of V_{CC}.

MAX4851/MAX4851H/MAX4853/MAX4853H

3.5Ω/7Ω Quad SPST Switches with Over-Rail Signal Handling

Test Circuits/Timing Diagrams

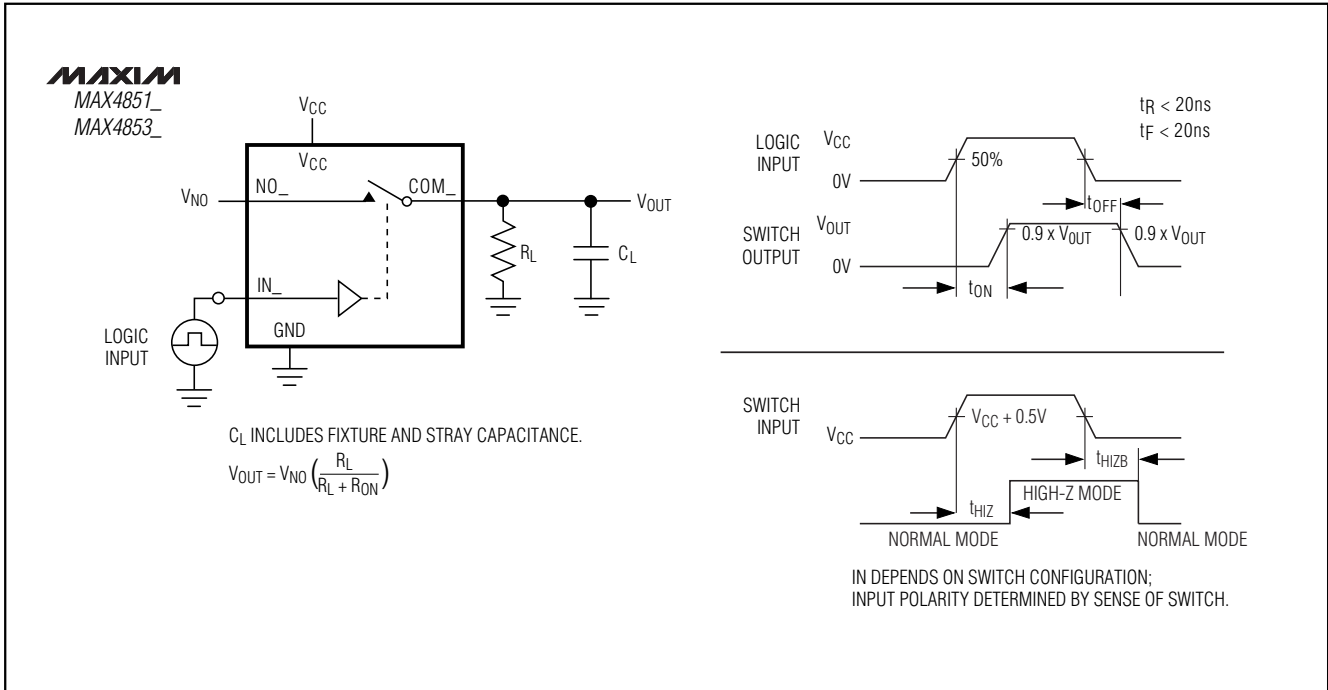

Figure 1. Switching Time

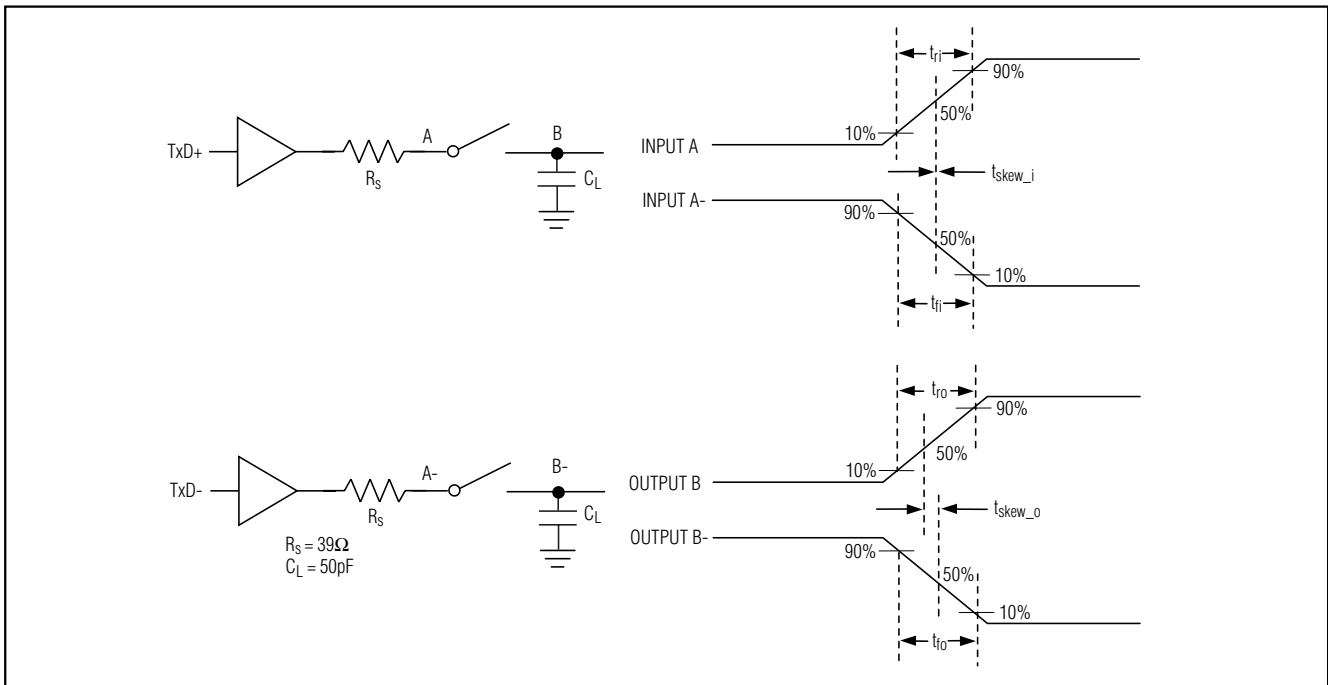

Figure 2. Input/Output Skew Timing Diagram

Quad SPST Switches with Over-Rail Signal Handling

Test Circuits/Timing Diagrams (continued)

MAX4851/MAX4851H/MAX4853/MAX4853H

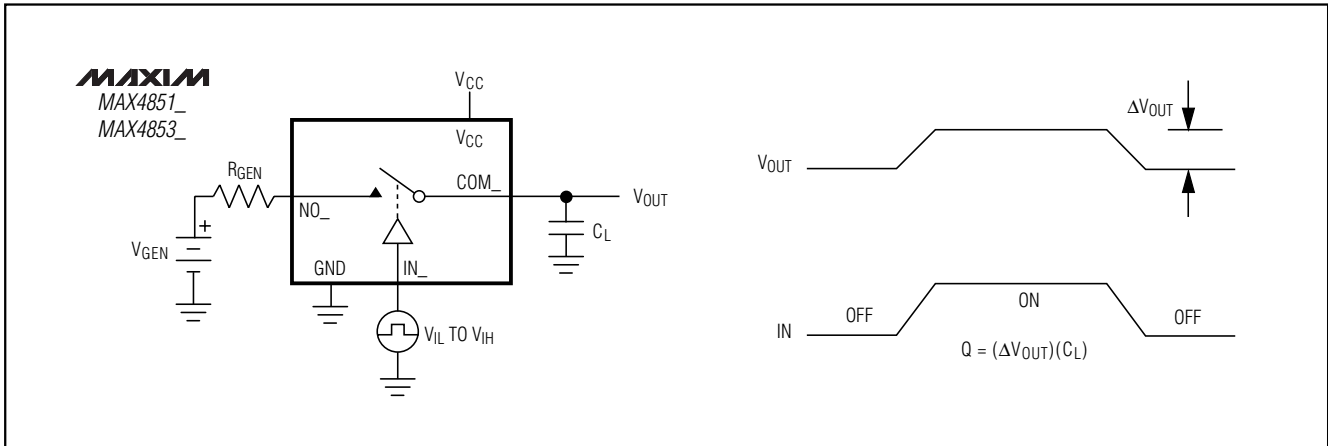

Figure 3. Charge Injection

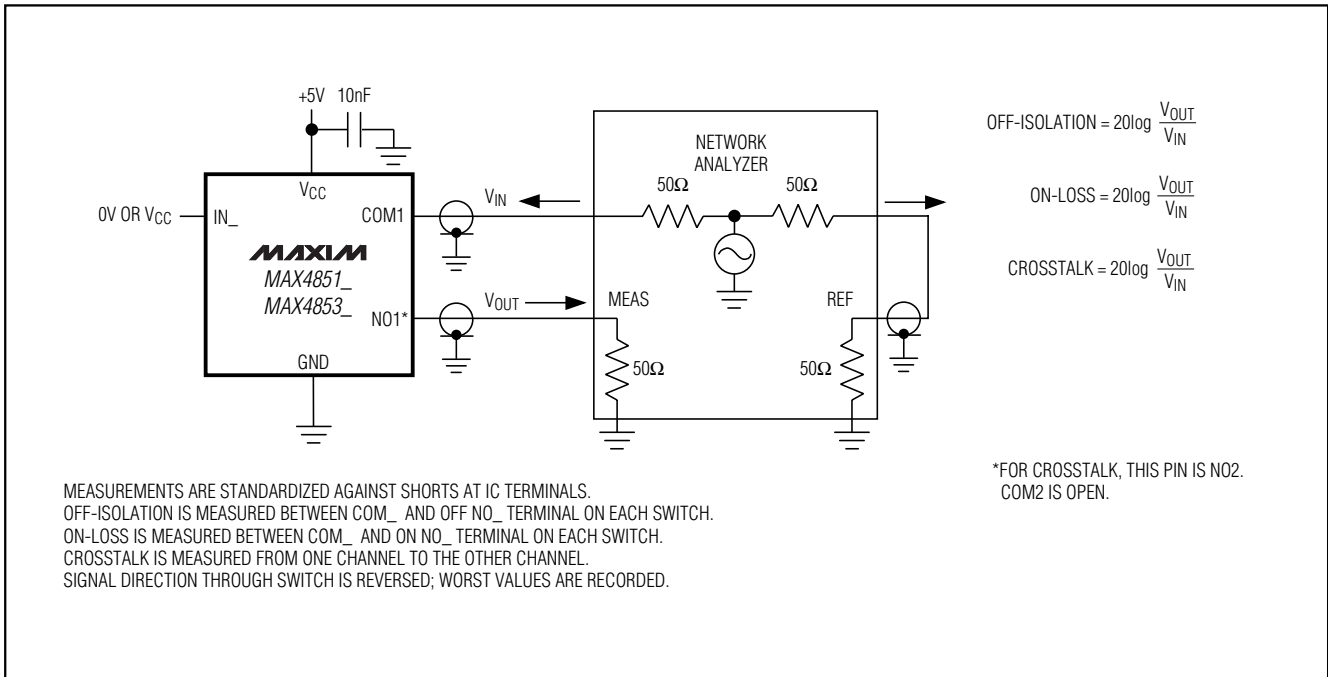

Figure 4. On-Loss, Off-Isolation, and Crosstalk

3.5Ω/7Ω Quad SPST Switches with Over-Rail Signal Handling

Applications Information

Digital Control Inputs

The logic inputs (IN₋) accept up to +5.5V even if the supply voltages are below this level. For example, with a +3.3V V_{CC} supply, IN₋ can be driven low to GND and high to +5.5V, allowing for mixing of logic levels in a system. Driving IN₋ rail-to-rail minimizes power consumption. For a +2V supply voltage, the logic thresholds are 0.5V (low) and 1.4V (high). For a +5V supply voltage, the logic thresholds are 0.8V (low) and 1.8V (high).

Analog Signal Levels

The on-resistance of these switches changes very little for analog input signals across the entire supply voltage range (see *Typical Operating Characteristics*). The switches are bidirectional; therefore, NO₋ and COM₋ can be either inputs or outputs.

Comparator

The positive terminal of the comparator is internally set to V_{CC} / 3. When the negative comparator terminal (CIN) is below the threshold (V_{CC} / 3), the comparator output (COUT) goes high. When CIN rises above V_{CC} / 3, COUT goes low.

The comparator threshold allows for detection of headphones since headphone audio signals are typically biased to V_{CC} / 2.

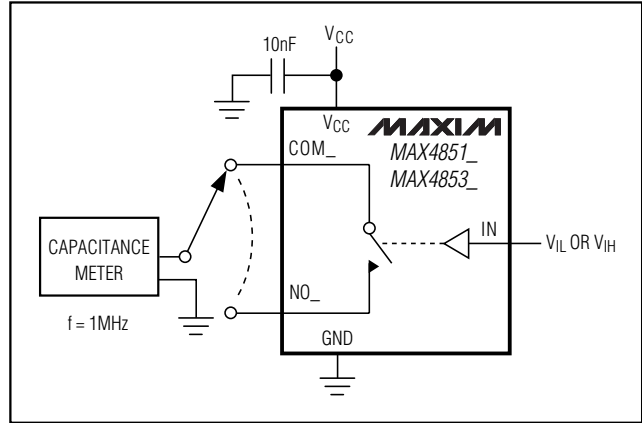

Figure 5. Channel Off-/On-Capacitance

Power-Supply Sequencing

Caution: Do not exceed the absolute maximum ratings because stresses beyond the listed ratings may cause permanent damage to the device.

Proper power-supply sequencing is recommended for all CMOS devices. Always apply V_{CC} before applying analog signals, especially if the analog signal is not current limited.

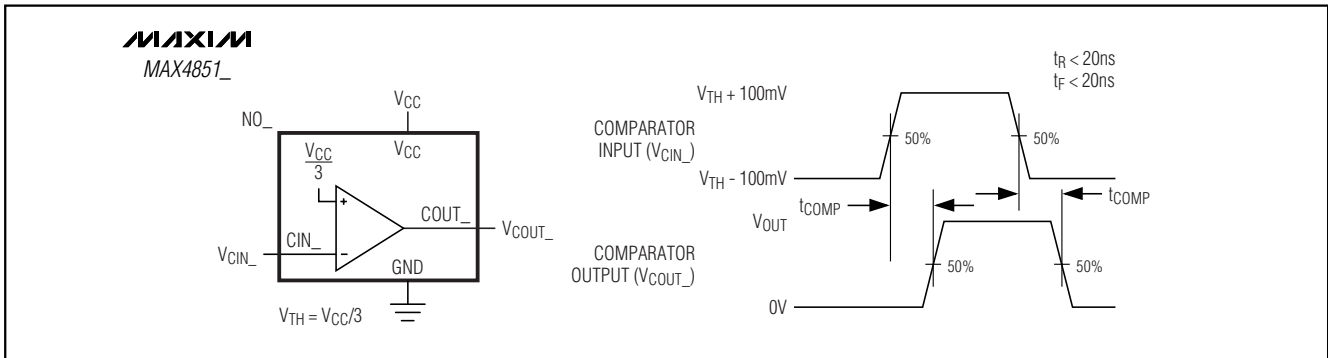

Figure 6. Comparator Switching Time

Selector Guide

PART	RON (Ω)		COMPARATORS	OVER-RAIL HANDLING
	NO1/NO3	NO2/NO4		
MAX4851	3.5	3.5	1	Input signal passes through the switch.
MAX4851H	3.5	3.5	1	High-impedance switch input.
MAX4853	3.5	7	—	Input signal passes through the switch.
MAX4853H	3.5	7	—	High-impedance switch input.

Quad SPST Switches with Over-Rail Signal Handling

Pin Configurations

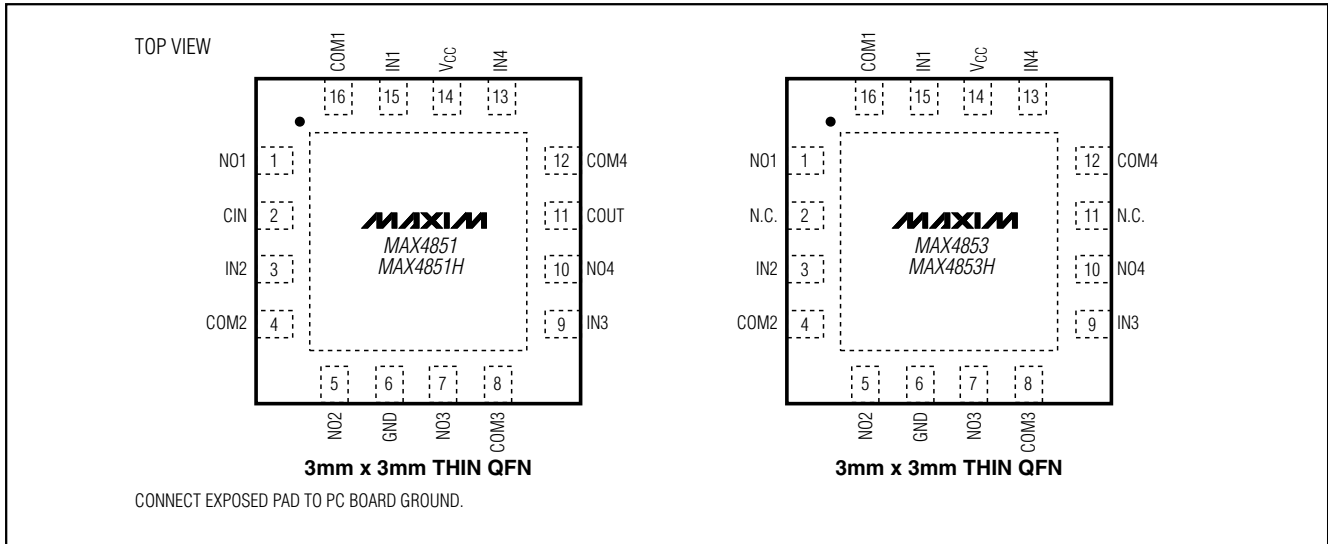

Typical Operating Circuit

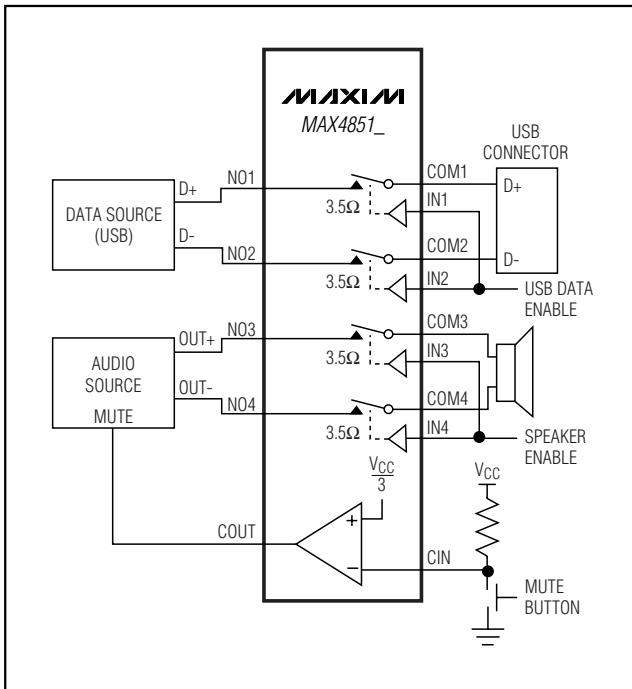

Chip Information

TRANSISTOR COUNT: 735
PROCESS: CMOS

MAX4851/MAX4851H/MAX4853/MAX4853H

3.5Ω/7Ω Quad SPST Switches with Over-Rail Signal Handling

Package Information

(The package drawing(s) in this data sheet may not reflect the most current specifications. For the latest package outline information, go to www.maxim-ic.com/packages.)

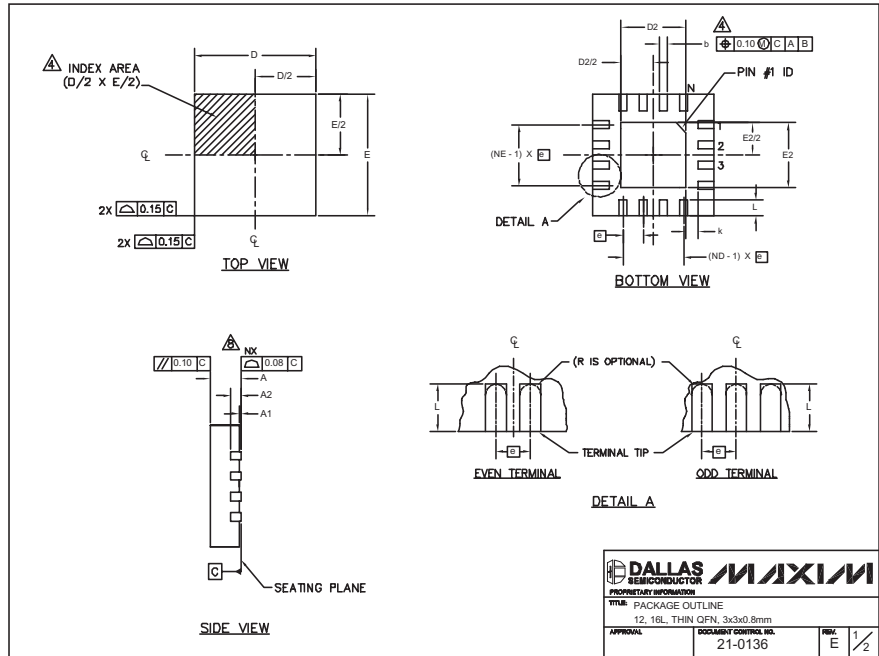

PKG REF.	12L 3x8			16L 3x8		
	MIN.	NOM.	MAX.	MIN.	NOM.	MAX.
A	0.70	0.75	0.80	0.70	0.75	0.80
b	0.20	0.25	0.30	0.20	0.25	0.30
D	2.90	3.00	3.10	2.90	3.00	3.10
E	2.90	3.00	3.10	2.90	3.00	3.10
ø	0.50 BSC			0.50 BSC		
L	0.45	0.55	0.65	0.30	0.40	0.50
N	12			16		
ND	3			4		
NE	3			4		
A1	0	0.02	0.05	0	0.02	0.05
A2	0.20 REF			0.20 REF		
k	0.25	-	-	0.25	-	-

PKG CODES	D2			E2			PIN ID	JEDEC	DOWN BONDS ALLOWED
	MIN.	NOM.	MAX.	MIN.	NOM.	MAX.			
T1233-1	0.95	1.10	1.25	0.95	1.10	1.25	0.35 x 45°	WEED-1	NO
T1233-3	0.95	1.10	1.25	0.95	1.10	1.25	0.35 x 45°	WEED-1	YES
T1633-1	0.95	1.10	1.25	0.95	1.10	1.25	0.35 x 45°	WEED-2	NO
T1633-2	0.95	1.10	1.25	0.95	1.10	1.25	0.35 x 45°	WEED-2	YES
T1633F-3	0.85	0.80	0.95	0.65	0.80	0.95	0.225 x 45°	WEED-2	N/A
T1633-4	0.95	1.10	1.25	0.95	1.10	1.25	0.35 x 45°	WEED-2	NO

NOTES:

1. DIMENSIONING & TOLERANCING CONFORM TO ASME Y14.5M-1994.
2. ALL DIMENSIONS ARE IN MILLIMETERS. ANGLES ARE IN DEGREES.
3. N IS THE TOTAL NUMBER OF TERMINALS.
4. THE TERMINAL #1 IDENTIFIER AND TERMINAL NUMBERING CONVENTION SHALL CONFORM TO JEDEC 95-1 SPP-012. DETAILS OF TERMINAL #1 IDENTIFIER ARE OPTIONAL, BUT MUST BE LOCATED WITHIN THE ZONE INDICATED. THE TERMINAL #1 IDENTIFIER MAY BE EITHER A MOLD OR MARKED FEATURE.
5. DIMENSION b APPLIES TO METALLIZED TERMINAL AND IS MEASURED BETWEEN 0.20 mm AND 0.25 mm FROM TERMINAL TIP.
6. ND AND NE REFER TO THE NUMBER OF TERMINALS ON EACH D AND E SIDE RESPECTIVELY.
7. DEPOPULATION IS POSSIBLE IN A SYMMETRICAL FASHION.
8. COPLANARITY APPLIES TO THE EXPOSED HEAT SINK SLUG AS WELL AS THE TERMINALS.
9. DRAWING CONFORMS TO JEDEC MO220 REVISION C.

DALLAS SEMICONDUCTOR **MAXIM**

PROPRIETARY INFORMATION

TITLE: PACKAGE OUTLINE
12: 16L, THIN QFN, 3x3x0.8mm

APPROVAL: _____ DOCUMENT CONTROL NO. 21-0136 REV. E 2/2

Maxim cannot assume responsibility for use of any circuitry other than circuitry entirely embodied in a Maxim product. No circuit patent licenses are implied. Maxim reserves the right to change the circuitry and specifications without notice at any time.

14 **Maxim Integrated Products, 120 San Gabriel Drive, Sunnyvale, CA 94086 408-737-7600**