

## SCHOTTKY BARRIER RECTIFIERS

Reverse Voltage - 40 to 200 V

Forward Current - 10 A

### FEATURES

- High current capability
- Low forward voltage drop
- Low power loss, high efficiency
- High surge capability
- High temperature soldering guaranteed
- Mounting position: any

### Mechanical data

- Case: TO-220
- Approx. Weight: 1.9g (0.067oz)
- Case: TO-220F
- Approx. Weight: 2.1g (0.07oz)
- Terminals: Lead solderable per MIL-STD-202, Method 208

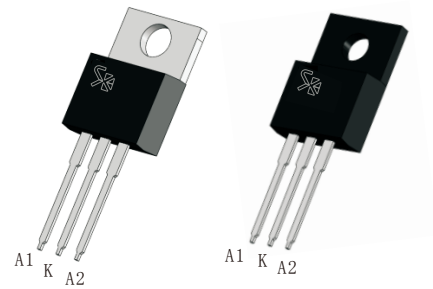

TO-220

TO-220F

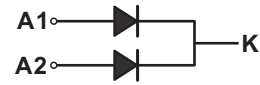

### MAXIMUM RATINGS AND ELECTRICAL CHARACTERISTICS

Ratings at 25°C ambient temperature unless otherwise specified

CHARACTERISTICS	TO-220	MBR1040CT	MBR1045CT	MBR1060CT	MBR10100CT	MBR10150CT	MBR10200CT	Units	
	TO-220F	MBR1040CTF	MBR1045CTF	MBR1060CTF	MBR10100CTF	MBR10150CTF	MBR10200CTF		
Maximum Recurrent Peak Reverse Voltage	$V_{RRM}$	40	45	60	100	150	200	V	
Maximum RMS voltage	$V_{RMS}$	28	31.5	42	70	105	140	V	
Maximum DC Blocking Voltage	$V_{DC}$	40	45	60	100	150	200	V	
Maximum Average Forward Rectified Current Per diode Per device	$I_{F(AV)}$	5 10						A	
Peak Forward Surge Current, 8.3ms Single Half Sine-wave Superimposed on Rated Load (JEDEC method) per diode	$I_{FSM}$	100						A	
Max Instantaneous Forward Voltage at 5A(per diode)	$V_F$	0.70		0.75	0.85	0.90	0.92	V	
Maximum DC Reverse Current $T_a = 25^\circ\text{C}$ at Rated DC Reverse Voltage $T_a = 125^\circ\text{C}$	$I_R$	0.1 20			0.05 20			mA	
Typical Junction Capacitance <sup>(1)</sup>	$C_j$	600		400				pF	
Typical Thermal Resistance <sup>(2)</sup>	$R_{\theta JA}$	45						°C/W	
Operating Junction Temperature Range	$T_j$	-55 ~ +150				-55 ~ +175			°C
Storage Temperature Range	$T_{stg}$	-55 ~ +150				-55 ~ +175			°C

(1) Measured at 1 MHz and applied reverse voltage of 4 V D.C

(2) P.C.B. mounted with 10cmX10cmX1mm copper pad areas.

Fig.1 TYPICAL FORWARD CURRENT DERATING CURVE

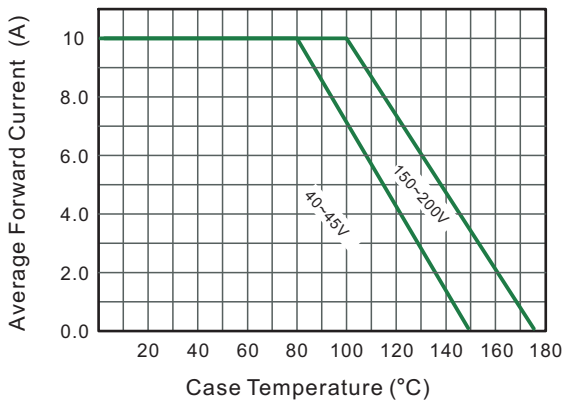

Fig.2 Typical Reverse Characteristics

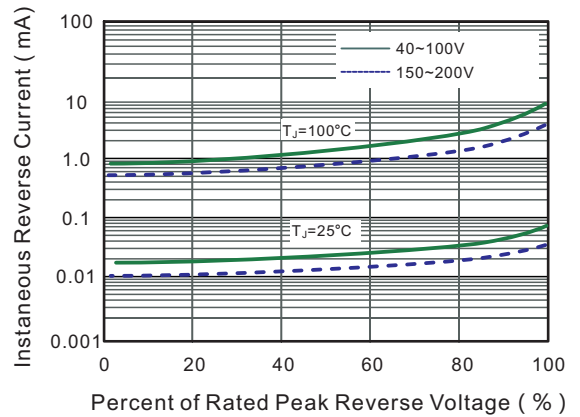

Fig.3 Typical Forward Characteristic(per leg)

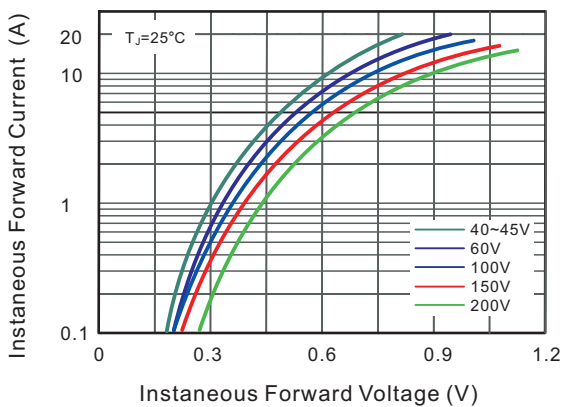

Fig.4 Typical Junction Capacitance

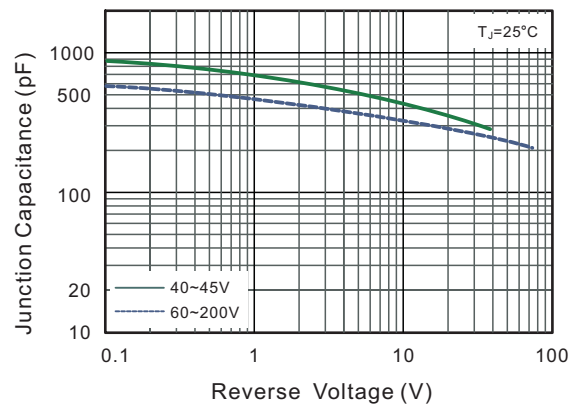

Fig.5 Maximum Non-Repetitive Peak Forward Surge Current

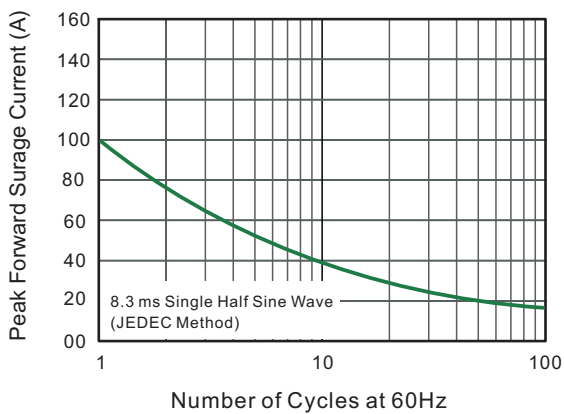
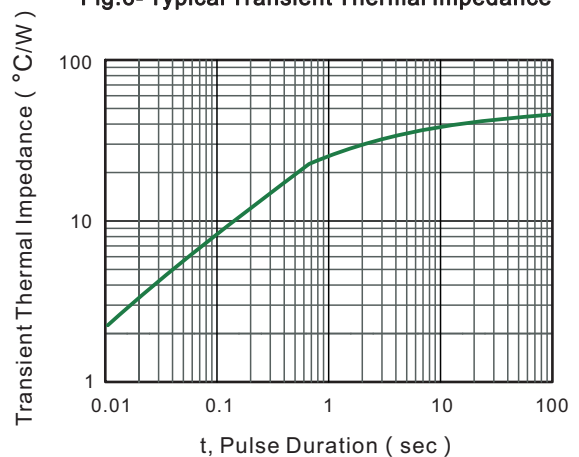

Fig.6- Typical Transient Thermal Impedance



## PACKAGE OUTLINE

Plastic surface mounted package; 2 leads

TO-220

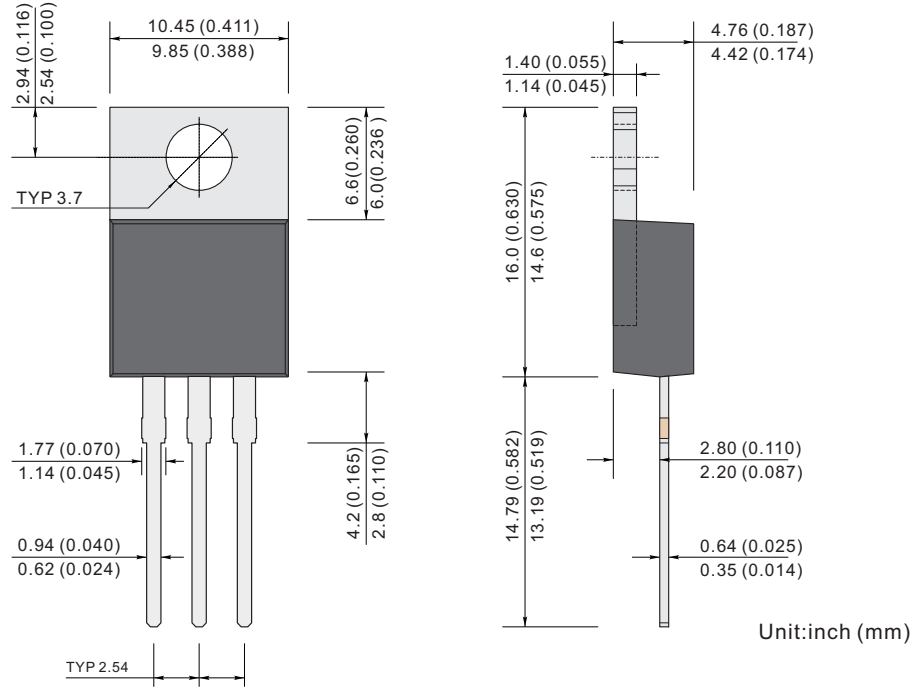

## PACKAGE OUTLINE

Plastic surface mounted package; 2 leads

TO-220F

