

MBRB20...CTPbF MBR20...CT-1PbF

SCHOTTKY RECTIFIER

20 Amp

$$I_{F(AV)} = 20\text{Amp}$$

$$V_R = 80/100\text{V}$$

Major Ratings and Characteristics

Characteristics	Values	Units
$I_{F(AV)}$ Rectangular waveform (Per Device)	20	A
I_{FRM} @ $T_C = 133^\circ\text{C}$ (PerLeg)	20	A
V_{RRM}	80/90/100	V
I_{FSM} @ $t_p = 5\mu\text{s}$ sine	850	A
V_F @ 10Apk, $T_J = 125^\circ\text{C}$	0.70	V
T_J range	-65 to 150	$^\circ\text{C}$

Description/ Features

This center tap Schottky rectifier has been optimized for low reverse leakage at high temperature. The proprietary barrier technology allows for reliable operation up to 150°C junction temperature. Typical applications are in switching power supplies, converters, free-wheeling diodes, and reverse battery protection.

- 150°C T_J operation
- Center tap TO-220, D²Pak and TO-262 packages
- Low forward voltage drop
- High purity, high temperature epoxy encapsulation for enhanced mechanical strength and moisture resistance
- High frequency operation
- Guard ring for enhanced ruggedness and long term reliability

Case Styles

MBRB20...CTPbF

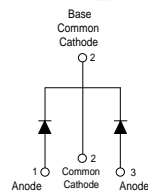
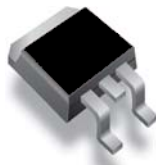

D²PAK

MBR20...CT-1PbF

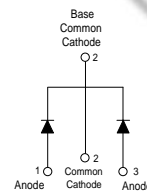
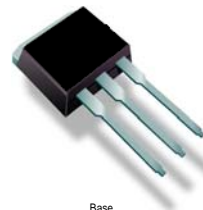

TO-262

MBRB20...CTPbF, MBR20...CT-1PbF Series

Bulletin PD-21019 rev. C 01/07

Voltage Ratings

Parameters	MBRB2080CTPbF MBR2080CT-1PbF	MBRB2090CTPbF MBR2090CT-1PbF	MBRB20100CTPbF MBR20100CT-1PbF
V_R Max. DC Reverse Voltage (V)	80	90	100
V_{RWM} Max. Working Peak Reverse Voltage (V)			

Absolute Maximum Ratings

Parameters	Values	Units	Conditions
$I_{F(AV)}$ Max. Average Forward Current (Per Leg) (Per Device)	10	A	@ $T_C = 133^\circ\text{C}$, (Rated V_R)
	20		
I_{FRM} Peak Repetitive Forward Current (Per Leg)	20	A	Rated V_R , square wave, 20kHz $T_C = 133^\circ\text{C}$
I_{FSM} Non Repetitive Peak Surge Current	850	A	5 μs Sine or 3 μs Rect. pulse Following any rated load condition and with rated V_{RRM} applied Surge applied at rated load conditions halfwave, single phase, 60Hz
	150		
I_{RRM} Peak Repetitive Reverse Surge Current	0.5	A	2.0 μsec 1.0KHz
E_{AS} Non-Repetitive Avalanche Energy (Per Leg)	24	mJ	$T_J = 25^\circ\text{C}$, $I_{AS} = 2$ Amps, $L = 12$ mH

Electrical Specifications

Parameters	Values	Units	Conditions
V_{FM} Max. Forward Voltage Drop (1)	0.80	V	@ 10A $T_J = 25^\circ\text{C}$
	0.95	V	@ 20A
	0.70	V	@ 10A $T_J = 125^\circ\text{C}$
	0.85	V	@ 20A
I_{RM} Max. Instantaneous Reverse Current (1)	0.10	mA	$T_J = 25^\circ\text{C}$ Rated DC voltage
	6	mA	$T_J = 125^\circ\text{C}$
$V_{F(TO)}$ Threshold Voltage	0.433	V	$T_J = T_J$ max.
r_t Forward Slope Resistance	15.8	m Ω	
C_T Max. Junction Capacitance	400	pF	$V_R = 5V_{DC}$ (test signal range 100Khz to 1Mhz) 25°C
L_S Typical Series Inductance	8.0	nH	Measured from top of terminal to mounting plane
dv/dt Max. Voltage Rate of Change	10000	V/ μs	(Rated V_R)

(1) Pulse Width < 300 μs , Duty Cycle <2%

Thermal-Mechanical Specifications

Parameters	Values	Units	Conditions
T_J Max. Junction Temperature Range	-65 to 150	$^\circ\text{C}$	
T_{stg} Max. Storage Temperature Range	-65 to 175	$^\circ\text{C}$	
R_{thJC} Max. Thermal Resistance Junction to Case (Per Leg)	2.0	$^\circ\text{C}/\text{W}$	DC operation
R_{thCS} Typical Thermal Resistance Case to Heatsink	0.50	$^\circ\text{C}/\text{W}$	Mounting surface, smooth and greased Only for TO-220
R_{thJA} Max. Thermal Resistance Junction to Ambient	50	$^\circ\text{C}/\text{W}$	DC operation For D ² Pak and TO-262
wt Approximate Weight	2(0.07)	g(oz.)	
T Mounting Torque	Min. 6(5)	Kg-cm (lbf-in)	Non-lubricated threads
	Max. 12(10)		
Marking Device	MBRB20...CT	Case style D ² Pak	
	MBR20...CT-1	Case style TO-262	

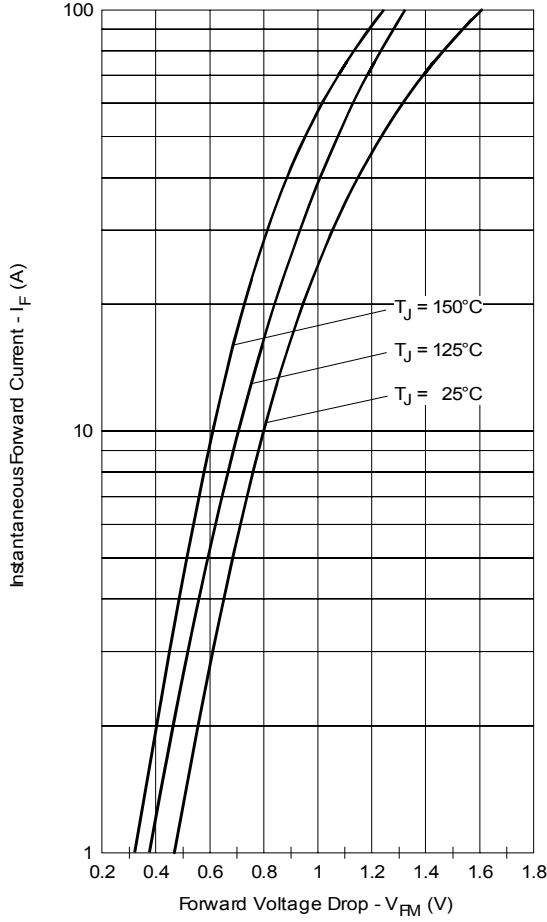

Fig. 1 - Max. Forward Voltage Drop Characteristics (PerLeg)

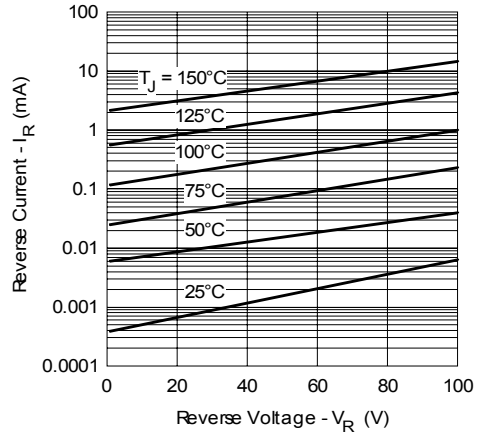

Fig. 2 - Typical Values Of Reverse Current Vs. Reverse Voltage (PerLeg)

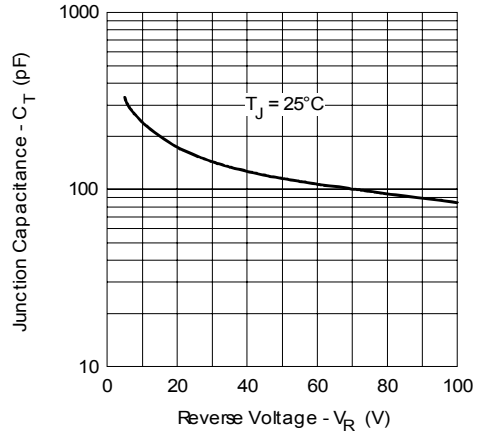

Fig. 3 - Typical Junction Capacitance Vs. Reverse Voltage (PerLeg)

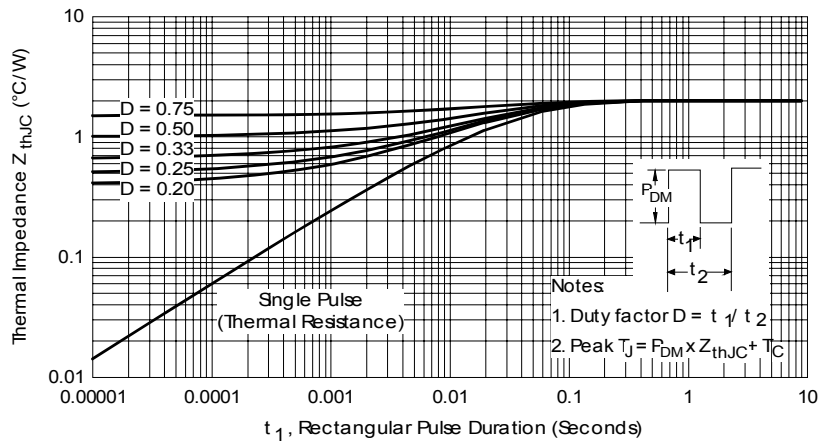

Fig. 4 - Max. Thermal Impedance Z_{thJC} Characteristics (PerLeg)

MBRB20...CTPbF, MBR20...CT-1PbF Series

Bulletin PD-21019 rev. C 01/07

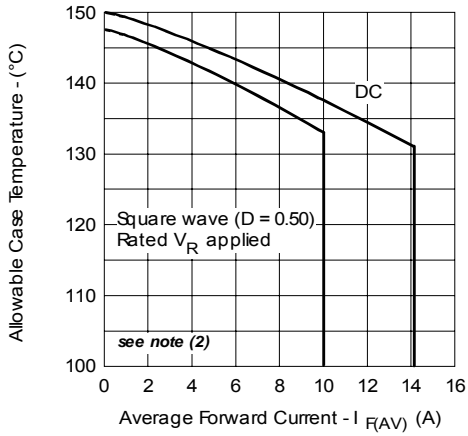

Fig. 5 - Max. Allowable Case Temperature Vs. Average Forward Current (Per Leg)

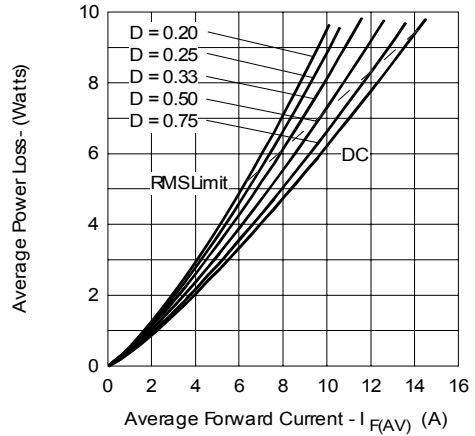

Fig. 6 - Forward Power Loss Characteristics (Per Leg)

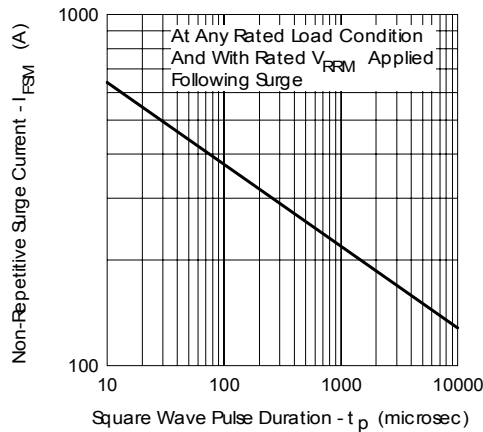
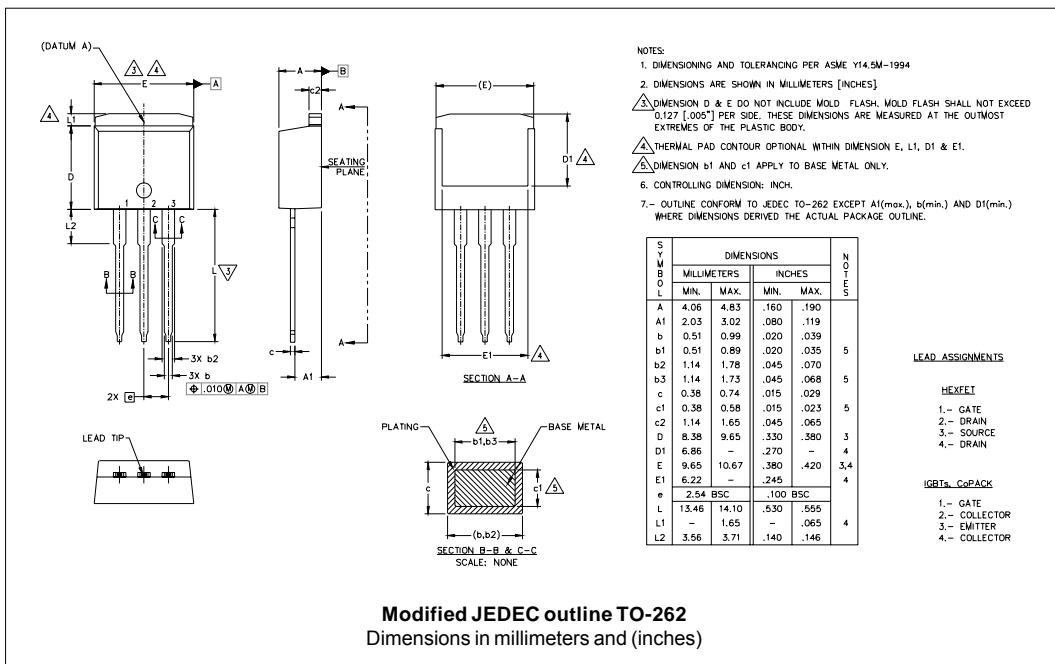
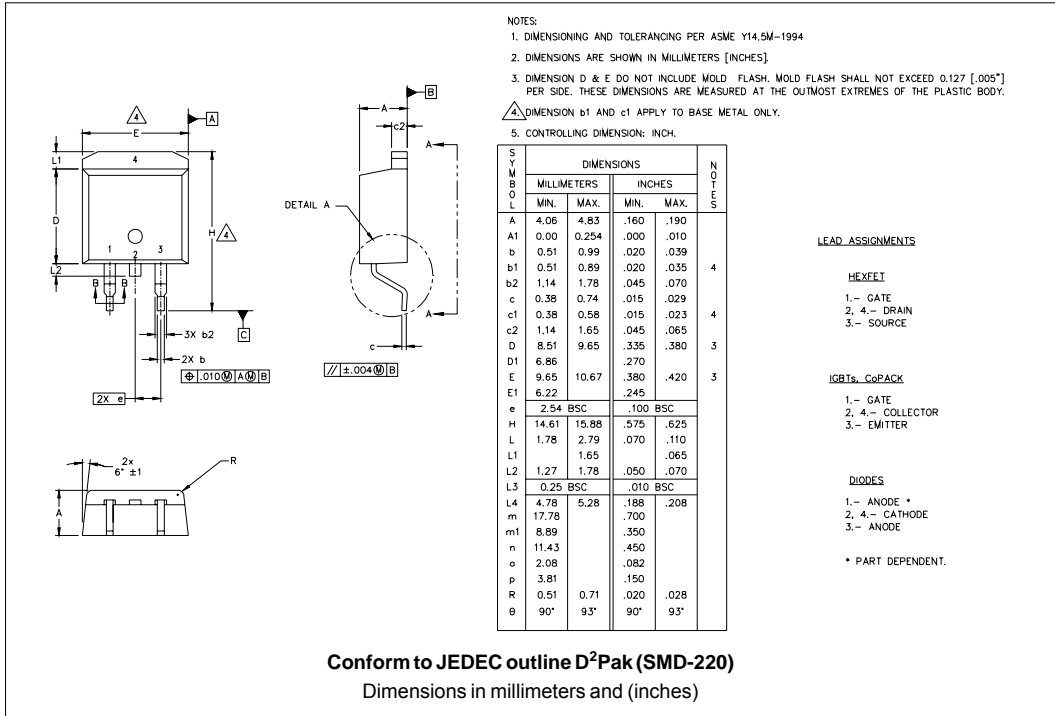

Fig. 7 - Max. Non-Repetitive Surge Current (Per Leg)

- (2) Formula used: $T_c = T_j - (Pd + Pd_{REV}) \times R_{thJC}$;
 $Pd = \text{Forward Power Loss} = I_{F(AV)} \times V_{FM} @ (I_{F(AV)} / D)$ (see Fig. 6);
 $Pd_{REV} = \text{Inverse Power Loss} = V_{R1} \times I_R (1 - D)$; $I_R @ V_{R1} = \text{rated } V_R$

Outlines Table



MBRB20...CTPbF, MBR20...CT-1PbF Series

Bulletin PD-21019 rev. C 01/07

Part Marking Information

D²PAK

EXAMPLE: THIS IS A MBRB20100CTPbF
LOT CODE 8024
ASSEMBLED ON WW 02, 2000

Note: "P" in assembly line position indicates "Lead-Free"

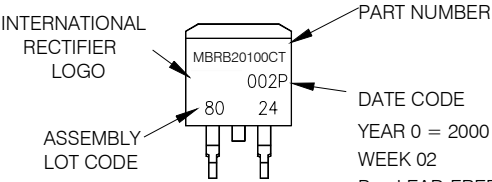

TO-262

EXAMPLE: THIS IS A MBR20100CT-1PbF
LOT CODE 1789
ASSEMBLED ON WW 19, 1999

Note: "P" in assembly line position indicates "Lead-Free"

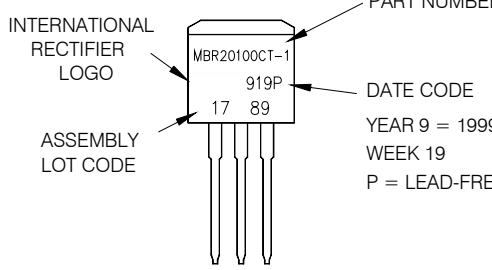

Tape & Reel Information

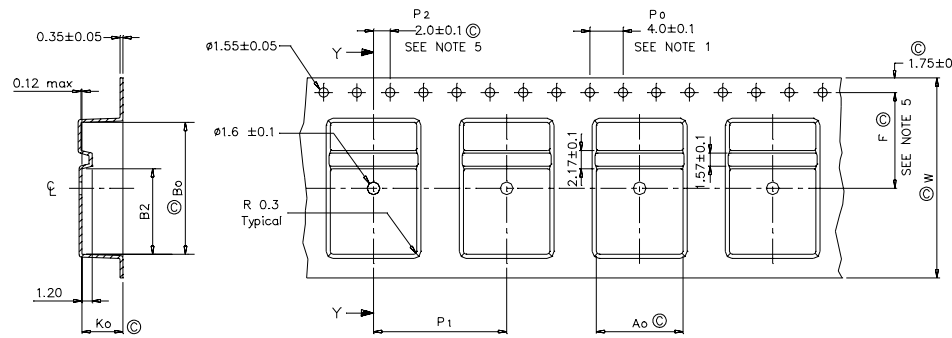

SECTION Y-Y

Ao	10.50	+/- 0.1
Bo	15.80	+/- 0.1
B2	10.25	+/- 0.1
Ko	4.90	+/- 0.1
F	11.50	+/- 0.1
P1	16.00	+/- 0.1
W	24.00	+/- 0.3

NOTES:

- 1.0 10 SPROCKET HOLE PITH CUMULATIVE TOLERANCE ±.02
- 2.0 CAMBER NOT TO EXCEED 1mm In 100mm
- 3.0 MATERIAL: CONDUCTIVE BLACK STYRENIC ALLOY
- 4.0 Ko MEASURED FROM A PLANE ON THE INSIDE BOTTOM OF THE POCKET TO THE TOP SURFACE OF THE CARRIER
- 5.0 MEASURED FROM CENTRELINE OF SPROCKET HOLE TO CENTRELINE OF POCKET
- 6.0 VENDOR: (OPTIONAL)
- 7.0 MUST ALSO MEET REQUIREMENTS OF EIA STANDAR #EIA-481A TAPING OF SURFACE MOUNT COMPONENTS FOR AUTOMATIC PLACEMENT
- 8.0 SURFACE RESISTIVITY OF MOLDED MATL. MUST MEASURE LESS OR EQUAL TO 10⁶ OHMS PER SQUARE. MEASURED IN ACCORDANCE TO PROCEDURE GIVEN IN ASTM D-257 & ASTM D-991
- 9.0 TOTAL LENGTH PER REEL MUST BE 45 METERS
- 10.0 © CRITICAL

Dimensions in millimeters and (inches)

Ordering Information Table

Device Code							
MBR	B	20	100	CT	-1	TRL	P
①	②	③	④	⑤	⑥	⑦	⑧
1	- Essential Part Number						
2	- • B = D ² Pak 6 none • none = TO-262 6 = -1						
3	- Current Rating (20 = 20A)						
4	- Voltage Ratings						
5	- CT = Essential Part Number						
6	• none = D ² Pak 2 = B • -1 = TO-262 2 none						
7	- • none = Tube (50 pieces) • TRL = Tape & Reel (Left Oriented - for D ² Pak only) • TRR = Tape & Reel (Right Oriented - for D ² Pak only)						
8	- • none = Standard Production • PbF = Lead-Free (for TO-262 and D ² Pak tube) • P = Lead-Free (for D ² Pak TRR and TRL)						

80 = 80V
 90 = 90V
 100 = 100V