



Dual Schottky Barrier Rectifiers
Reverse Voltage 150 Volts Forward Current 30.0 Amperes

Features

- ◆ Plastic package has Underwriters Laboratory Flammability Classification 94V-0
- ◆ Dual rectifier construction, positive center tap
- ◆ Metal silicon junction, majority carrier conduction
- ◆ Low power loss, high efficiency
- ◆ Guardring for overvoltage protection
- ◆ For use in low voltage, high frequency inverters, free wheeling, and polarity protection applications
- ◆ High temperature soldering guaranteed:
250°C/10 seconds, 0.25" (6.35mm) from case

Mechanical Data

- ◆ Case: JEDEC TO-22B, TO-220F, TO-263 molded plastic body
- ◆ Terminals: Plated leads, solderable per MIL-STD-750, Method 2026
- ◆ Polarity: As marked
- ◆ Mounting Position: Any
- ◆ Mounting Torque: 10 in-lbs maximum
- ◆ Weight: 0.08 ounce, 2.24 grams

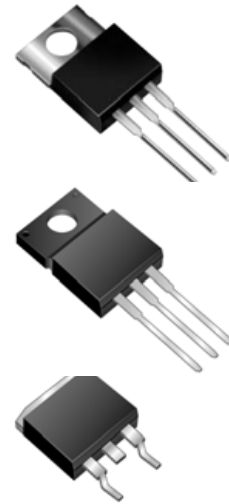

TO-220

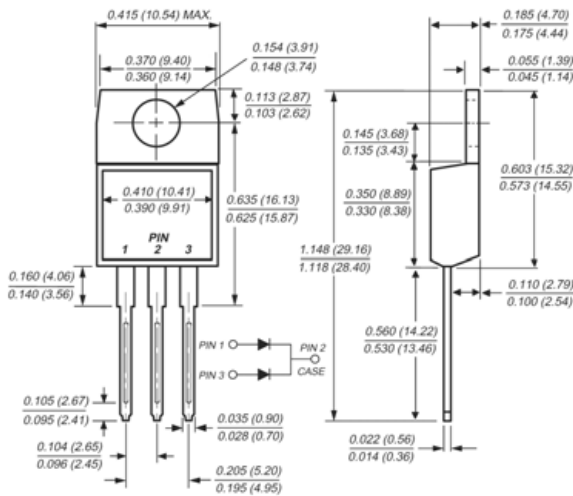

TO-220F

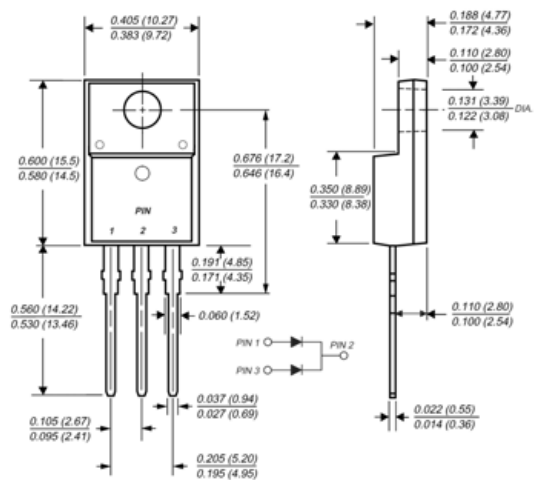

TO-263(D²PAK)

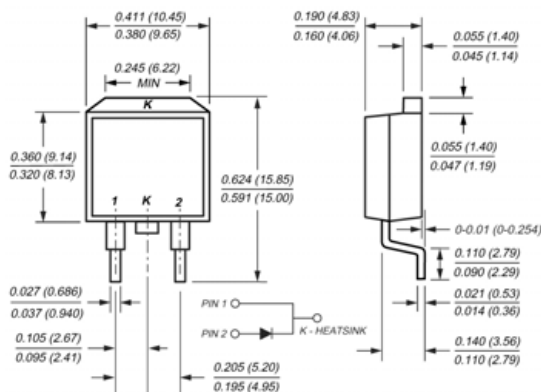

Mounting Pad Layout TO-263

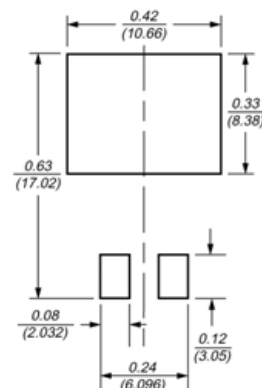

Dimensions in inches and (millimeters)

**MAXIMUM RATINGS ($T_a=25^{\circ}\text{C}$ unless otherwise noted)**

Symbol	Parameter	Value	Unit
V_{RRM}	Peak repetitive reverse voltage	150	V
V_{RWM}	Working peak reverse voltage		
V_R	DC blocking voltage		
$V_{R(RMS)}$	RMS reverse voltage	105	V
I_O	Average rectified output current	30	A
I_{FSM}	Non-Repetitive peak forward surge current 8.3ms half sine wave	200	A
P_D	Power dissipation	2	W
$R_{\theta JA}$	Thermal resistance from junction to ambient	50	$^{\circ}\text{C}/\text{W}$
T_j	Junction temperature	125	$^{\circ}\text{C}$
T_{stg}	Storage temperature	-55~+150	$^{\circ}\text{C}$

ELECTRICAL CHARACTERISTICS ($T_a=25^{\circ}\text{C}$ unless otherwise specified)

Parameter	Symbol	Test conditions	Min	Typ	Max	Unit
Reverse voltage	$V_{(BR)}$	$I_R=1\text{mA}$	200			V
Reverse current	I_R	$V_R=150\text{V}$			0.1	mA
Forward voltage	V_{F1}	$I_F=15\text{A}$			0.95	V
	V_{F2}^*	$I_F=30\text{A}$			1.1	V
Typical total capacitance	C_{tot}	$V_R=4\text{V}, f=1\text{MHz}$		800		pF

*Pulse test



Rating and Characteristic Curves

Forward Characteristics

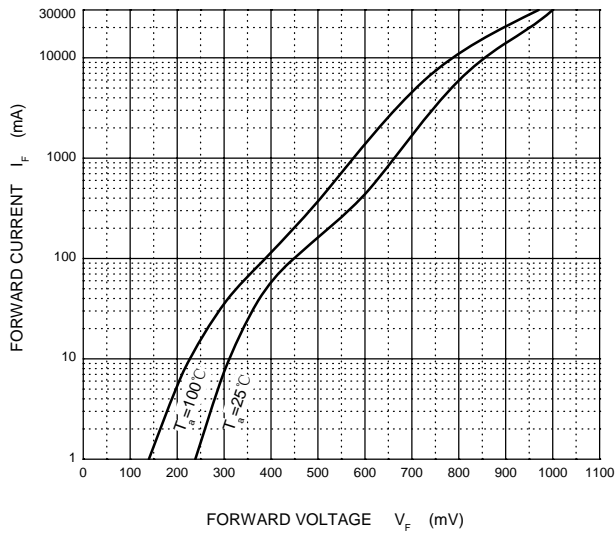

Reverse Characteristics

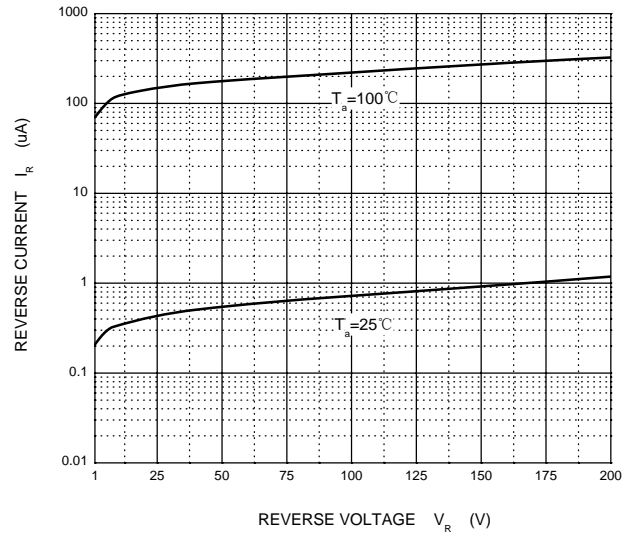

Capacitance Characteristics

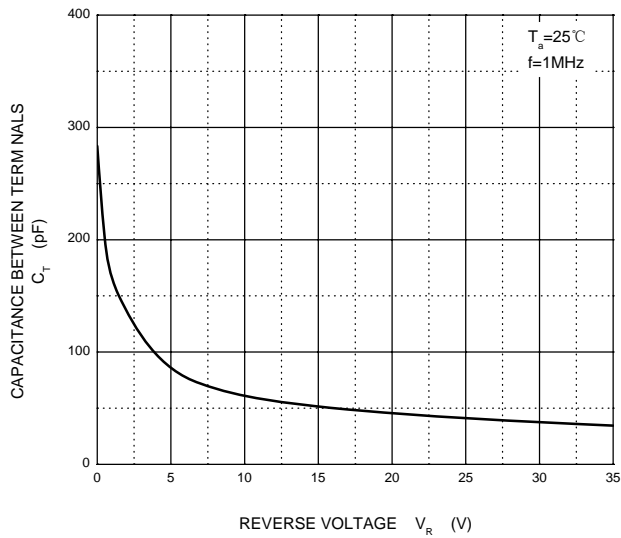

Power Derating Curve

