

2:1 Multiplexer

The MC10EL/100EL58 is a 2:1 multiplexer. The device is functionally equivalent to the E158 device with higher performance capabilities. With propagation delays and output transition times significantly faster than the E158 the EL58 is ideally suited for those applications which require the ultimate in AC performance.

- 230ps Propagation Delay
- High Bandwidth Output Transitions
- 75kΩ Internal Input Pulldown Resistors
- >1000V ESD Protection

MC10EL58 MC100EL58



D SUFFIX
PLASTIC SOIC PACKAGE
CASE 751-05

LOGIC DIAGRAM AND PINOUT ASSIGNMENT

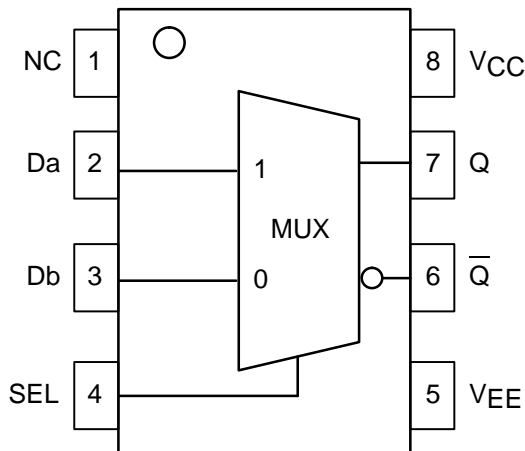

FUNCTION TABLE

SEL	Data
H	a
L	b

PIN DESCRIPTION

PIN	FUNCTION
D0, D1	Data Inputs
Q	Data Outputs

DC CHARACTERISTICS (VEE = VEE(min) to VEE(max); VCC = GND)

Symbol	Characteristic		-40°C			0°C			25°C			85°C			Unit
			Min	Typ	Max	Min	Typ	Max	Min	Typ	Max	Min	Typ	Max	
I _{EE}	Power Supply Current	10EL 100EL		14 14	17 17		14 14	17 17		14 14	17 17		14 16	17 19	mA
V _{EE}	Power Supply Voltage	10EL 100EL	-4.94 -4.20	-5.2 -4.5	-5.5 -5.5	-4.94 -4.20	-5.2 -4.5	-5.5 -5.5	-4.75 -4.20	-5.2 -4.5	-5.5 -5.5	-4.75 -4.20	-5.2 -4.5	-5.5 -5.5	V
I _{IH}	Input HIGH Current				150			150			150			150	μA

AC CHARACTERISTICS (VEE = VEE(min) to VEE(max); VCC = GND)

Symbol	Characteristic		-40°C			0°C			25°C			85°C			Unit
			Min	Typ	Max	Min	Typ	Max	Min	Typ	Max	Min	Typ	Max	
t _{PLH} t _{PHL}	Propagation Delay to Output	D to Q SEL to Q	60 90	220 250	380 410	110 140	220 250	330 360	120 150	230 260	340 370	140 170	250 280	360 390	ps
t _r t _f	Output Rise/Fall Times Q (20% - 80%)		100	225	350	100	225	350	100	225	350	100	225	350	ps



OUTLINE DIMENSIONS

D SUFFIX
PLASTIC SOIC PACKAGE
CASE 751-05
ISSUE P

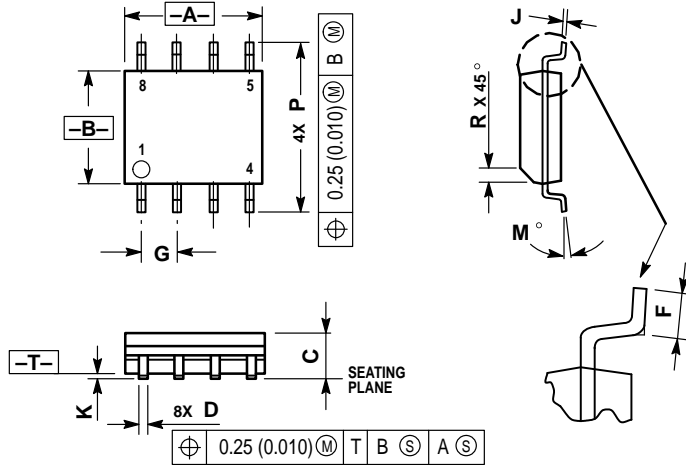

NOTES:

1. DIMENSIONS A AND B ARE DATUMS AND T IS A DATUM SURFACE.
2. DIMENSIONING AND TOLERANCING PER ANSI Y14.5M, 1982.
3. DIMENSIONS ARE IN MILLIMETER.
4. DIMENSION A AND B DO NOT INCLUDE MOLD PROTRUSION.
5. MAXIMUM MOLD PROTRUSION 0.15 PER SIDE.
6. DIMENSION D DOES NOT INCLUDE MOLD PROTRUSION. ALLOWABLE DAMBAR PROTRUSION SHALL BE 0.127 TOTAL IN EXCESS OF THE D DIMENSION AT MAXIMUM MATERIAL CONDITION.

DIM	MILLIMETERS	
	MIN	MAX
A	4.80	5.00
B	3.80	4.00
C	1.35	1.75
D	0.35	0.49
F	0.40	1.25
G	1.27 BSC	
J	0.18	0.25
K	0.10	0.25
M	0°	7°
P	5.80	6.20
R	0.25	0.50

Motorola reserves the right to make changes without further notice to any products herein. Motorola makes no warranty, representation or guarantee regarding the suitability of its products for any particular purpose, nor does Motorola assume any liability arising out of the application or use of any product or circuit, and specifically disclaims any and all liability, including without limitation consequential or incidental damages. "Typical" parameters which may be provided in Motorola data sheets and/or specifications can and do vary in different applications and actual performance may vary over time. All operating parameters, including "Typicals" must be validated for each customer application by customer's technical experts. Motorola does not convey any license under its patent rights nor the rights of others. Motorola products are not designed, intended, or authorized for use as components in systems intended for surgical implant into the body, or other applications intended to support or sustain life, or for any other application in which the failure of the Motorola product could create a situation where personal injury or death may occur. Should Buyer purchase or use Motorola products for any such unintended or unauthorized application, Buyer shall indemnify and hold Motorola and its officers, employees, subsidiaries, affiliates, and distributors harmless against all claims, costs, damages, and expenses, and reasonable attorney fees arising out of, directly or indirectly, any claim of personal injury or death associated with such unintended or unauthorized use, even if such claim alleges that Motorola was negligent regarding the design or manufacture of the part. Motorola and are registered trademarks of Motorola, Inc. Motorola, Inc. is an Equal Opportunity/Affirmative Action Employer.

How to reach us:

USA/EUROPE/Locations Not Listed: Motorola Literature Distribution; P.O. Box 20912; Phoenix, Arizona 85036. 1-800-441-2447 or 602-303-5454

JAPAN: Nippon Motorola Ltd.; Tatsumi-SPD-JLDC, 6F Seibu-Butsuryu-Center, 3-14-2 Tatsumi Koto-Ku, Tokyo 135, Japan. 03-81-3521-8315

MFAX: RMFAX0@email.sps.mot.com - TOUCHTONE 602-244-6609
INTERNET: http://Design-NET.com

ASIA/PACIFIC: Motorola Semiconductors H.K. Ltd.; 8B Tai Ping Industrial Park, 51 Ting Kok Road, Tai Po, N.T., Hong Kong. 852-26629298

