

MC1489/MC1489A

Quad line receivers

Document No.	853-0934
ECN No.	91023
Date of Issue	October 20, 1987
Status	Product Specification
Data Communication Products	

DESCRIPTION

The MC1489/MC1489A are quad line receivers designed to interface data terminal equipment with data communications equipment. They are constructed on a single monolithic silicon chip. These devices satisfy the specifications of EIA standard No. RS-232C.

FEATURES

- Four totally separate receivers per package
- Programmable threshold
- Built-in input threshold hysteresis
- "Fail safe" operating mode
- Inputs withstand $\pm 30V$

APPLICATIONS

- Computer port inputs
- Modems
- Eliminating noise in digital circuitry
- MOS-to-TTL/DTL translation

PIN CONFIGURATION

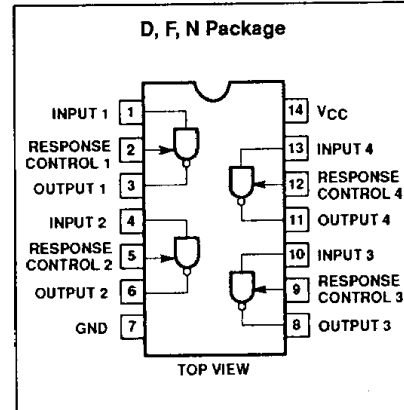

ORDERING INFORMATION

DESCRIPTION	TEMPERATURE RANGE	ORDER CODE
14-Pin Plastic DIP	0°C to +70°C	MC1489N
14-Pin Plastic DIP	0°C to +70°C	MC1489AN
14-Pin Cerdip	0°C to +70°C	MC1489F
14-Pin Cerdip	0°C to +70°C	MC1489AF
14-Pin Plastic SO	0°C to +70°C	MC1489D
14-Pin Plastic SO	0°C to +70°C	MC1489AD

EQUIVALENT SCHEMATIC

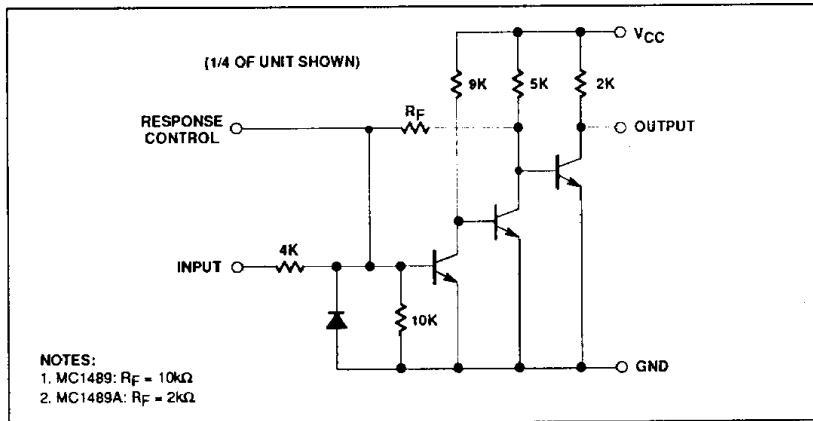

Quad line receivers

MC1489/MC1489A

ABSOLUTE MAXIMUM RATINGS

SYMBOL	PARAMETER	RATING	UNIT
V_{CC}	Power supply voltage	10	V
V_{IN}	Input voltage range	± 30	V
I_{OUT}	Output load current	20	mA
P_D	Maximum power dissipation, $T_A = 25^\circ\text{C}$ (still-air) ¹		
	F package	1190	mW
	N package	1420	mW
	D package	1040	mW
T_A	Operating temperature range	0 to +75	$^\circ\text{C}$
T_{STG}	Storage temperature range	-65 to +150	$^\circ\text{C}$

VOLTAGE WAVEFORMS

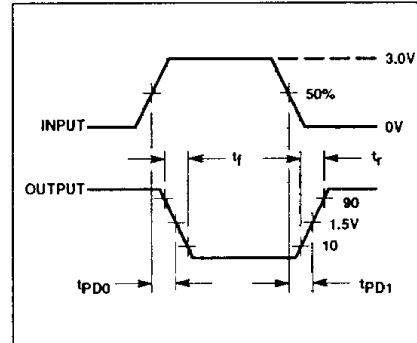

NOTE:

- Derate above 25°C , at the following rates:
F package at $9.5\text{mW}/^\circ\text{C}$
N package at $11.4\text{mW}/^\circ\text{C}$
D package at $8.3\text{mW}/^\circ\text{C}$

DC ELECTRICAL CHARACTERISTICS $V_{CC} = 5.0\text{V} \pm 1\%$, $0^\circ\text{C} \leq T_A \leq +75^\circ\text{C}$, unless otherwise specified.^{1, 2}

SYMBOL	PARAMETER	TEST CONDITIONS	MC1489			MC1489A			UNIT
			Min	Typ	Max	Min	Typ	Max	
V_{IH}	Input high threshold voltage	$T_A = 25^\circ\text{C}$, $V_{OUT} \leq 0.45\text{V}$, $I_{OUT} = 10\text{mA}$	1.0		1.5	1.75		2.25	V
V_{IL}	Input low threshold voltage	$T_A = 25^\circ\text{C}$, $V_{OUT} \geq 2.5\text{V}$, $I_{OUT} = -0.5\text{mA}$	0.75		1.25	0.75		1.25	V
I_{IN}	Input current	$V_{IN} = +25\text{V}$ $V_{IN} = -25\text{V}$ $V_{IN} = +3\text{V}$ $V_{IN} = -3\text{V}$	+3.6 -3.6 +0.43 -0.43	+5.6 -5.6 +0.53 -0.53	+8.3 -8.3	+3.6 -3.6 +0.43 -0.43	+5.6 -5.6 +0.53 -0.53	+8.3 -8.3	mA
V_{OH}	Output high voltage	$V_{IN} = 0.75\text{V}$, $I_{OUT} = -0.5\text{mA}$	2.6	3.8	5.0	2.6	3.8	5.0	V
V_{OL}	Output low voltage	Input = Open, $I_{OUT} = -0.5\text{mA}$ $V_{IN} = 3.0\text{V}$, $I_{OUT} = 10\text{mA}$	2.6	3.8	5.0	2.6	3.8	5.0	V
I_{SC}	Output short-circuit current	$V_{IN} = 0.75\text{V}$		3.0			3.0		mA
I_{CC}	Supply current	$V_{IN} = 5.0\text{V}$		20	26		20	26	mA
P_D	Power dissipation	$V_{IN} = 5.0\text{V}$		100	130		100	130	mW

NOTES:

- Voltage values shown are with respect to network ground terminal. Positive current is defined as current into the referenced pin.
- These specifications apply for response control pin = open.

AC ELECTRICAL CHARACTERISTICS $V_{CC} = 5.0\text{V} \pm 1\%$, $T_A = 25^\circ\text{C}$, unless otherwise specified.^{1, 2}

SYMBOL	PARAMETER	TEST CONDITIONS	MC1489			MC1489A			UNIT
			Min	Typ	Max	Min	Typ	Max	
t_{PD1}	Input to output "high" Propagation delay	$R_L = 3.9\text{k}\Omega$ (AC test circuit)		25	85		25	85	ns
t_{PD0}	Input to output "low" Propagation delay	$R_L = 390\Omega$ (AC test circuit)		20	50		20	50	ns
t_R	Output rise time	$R_L = 3.9\text{k}\Omega$ (AC test circuit)		110	175		110	175	ns
t_F	Output fall time	$R_L = 390\Omega$ (AC test circuit)		9	20		9	20	ns

NOTES:

- Voltage values shown are with respect to network ground terminal. Positive current is defined as current into the referenced pin.
- These specifications apply for response control pin = open.

Quad line receivers

MC1489/MC1489A

AC TEST CIRCUIT

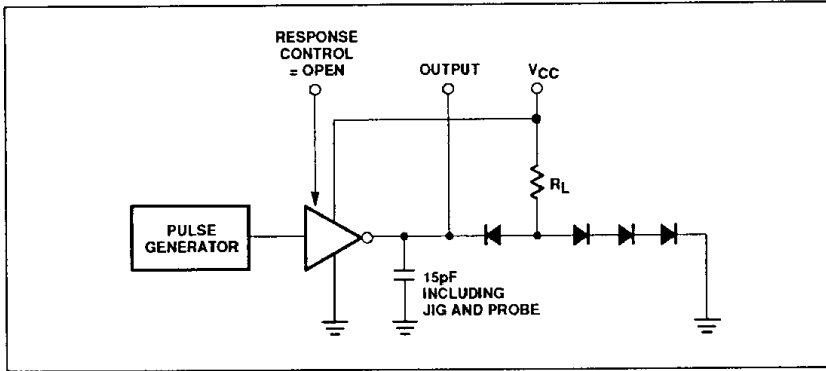

TYPICAL APPLICATIONS

