

MGF7170AC

UHF BAND GaAs POWER AMPLIFIER

Technical Note

Specifications are subject to change without notice.

DESCRIPTION

The MGF7170AC is a monolithic microwave integrated circuit for use in CDMA base handheld phone.

FEATURES

- Low voltage operation :
Vd=3.0V
- High output power :
Po=28dBm typ. @f=1.715~1.78GHz
- Low distortion :
ACP=-46dBc max. @Po=28dBm
- High efficiency :
Id=520mA typ. @Po=28dBm
- Small size :
7.0 x 6.1 x 1.1 mm
- Single voltage operation (NVG include)
- Surface mount package
- 2 Stage Amplifier
- External matching circuit is required

APPLICATION

1.9GHz band handheld phone

QUALITY GRADE

GG

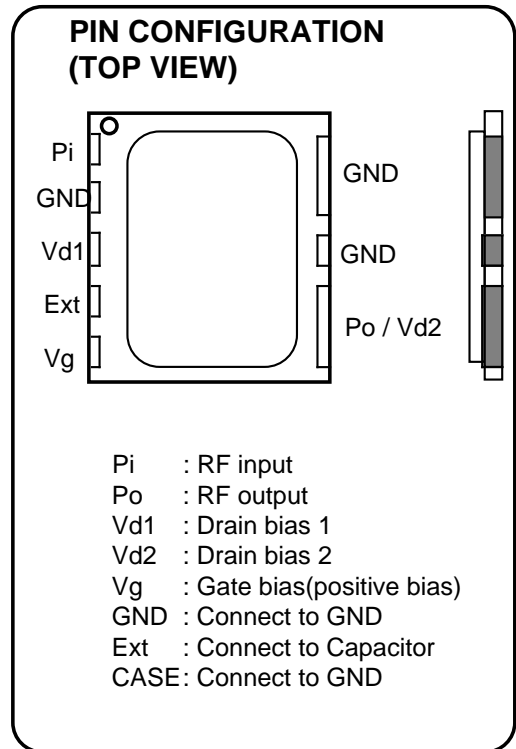

ES1:different pin configuration

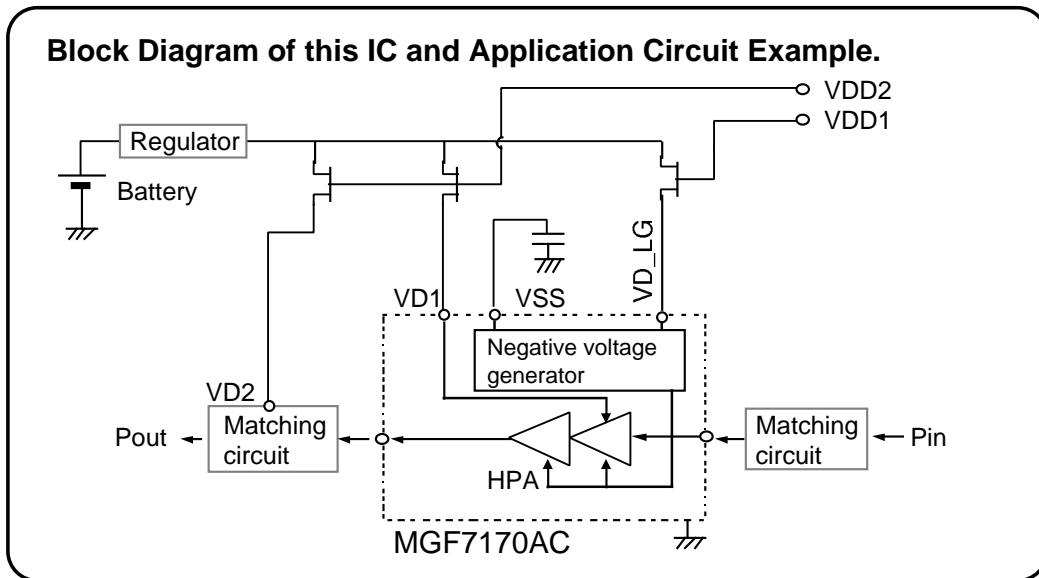

*Mitsubishi Electric Corporation puts the maximum effort into making semiconductor products better and reliable, but there is always the possibility that trouble may occur with them. Trouble with semiconductors may lead to personal injury, fire or property damage. Remember to give due consideration to safety when making your circuit designs, with appropriate measures such as (i) placement of substitutive, auxiliary, circuits, (ii) use of non-flammable material or (iii) prevention against any malfunction or mishap.

Preliminary
information

MGF7170AC

UHF BAND GaAs POWER AMPLIFIER

ABSOLUTE MAXIMUM RATINGS (Ta=25 deg.C)

Symbol	Parameter	Ratings	Unit
Vd1,Vd2	Drain supply voltage	6	V
Vg	Gate supply voltage	4	V
Pi	Input power	15	dBm
Tc(op)	Operating case temperature	-30 ~ +85	deg.C
Tstg	Storage temperature	-30 ~ +100	deg.C

*1.Each maximum rating is guaranteed independently.

ELECTRICAL CHARACTERISTICS (Ta=25 deg.C)

Symbol	Parameter	Test conditions	Limits			Unit
			MIN	TYP	MAX	
f	frequency		1715	—	1780	MHz
Idt	Total drain current	ACP<-42dBc (1.25MHz off-set.) Vd1=Vd2=3.0V	—	450	—	mA
		ACP<-44dBc (1.25MHz off-set.) Vd1=Vd2=3.0V	—	480	—	
		ACP<-46dBc (1.25MHz off-set.) Vd1=Vd2=3.0V	—	520	—	
		ACP<-44dBc (1.25MHz off-set.) Vd1=Vd2=3.3V	—	450	—	
Idle_Id	Idle current	Vg=2.6V, Po=28dBm	—	150	—	mA
		Vg=2.9V, Po=12dBm	—	50	—	
Pout	Output power	Vd1=Vd2=3.0V, Vg=2.6V, Pin=7dBm CDMA modulated signal based on IS-95 STD. (1.2288Mbps spreading, OQPSK)	—	28	—	dBm
Ig	Gate current		—	10	—	mA
2sp	2nd harmonics		—	—	-30	dBc
rin	input VSWR		—	—	3	—
—	Damage with-standing Note		Vd1=Vd2=3.0V, Pin=7dBm, Load VSWR=10, All phase Time=10 sec	No damage		
—	Stability Note	Vd1=Vd2=3.0V, Pin=7dBm, Load VSWR=3:1, All phase	No oscillation Spurious level -60dBc			

*CDMA is code division multiple Access. OQPSK is modulation method, off-set quadrature phase shift keying.

Electrical characteristics are changed by the external matching circuit.

Limits are guaranteed by using MITSUBISHI test fixture.

Note : Sampling inspection

Preliminary
information

MGF7170AC

UHF BAND GaAs POWER AMPLIFIER

Pin vs. Pout, Id for CDMA

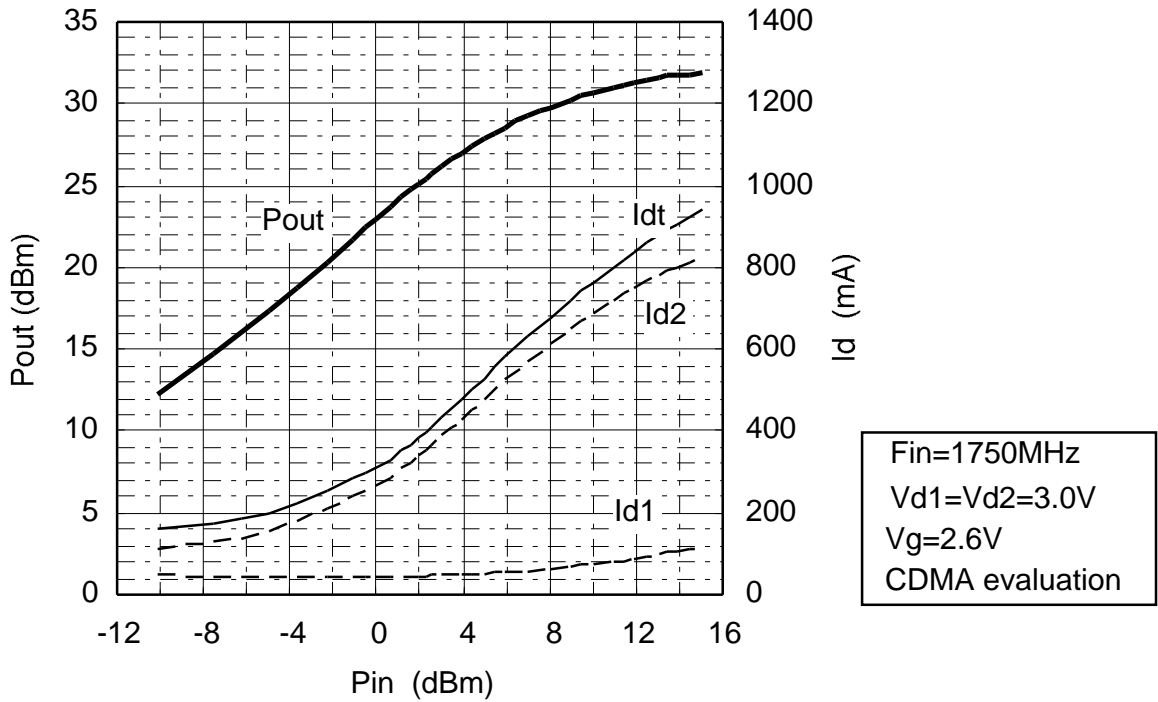

Pin vs. Pout, Efficiency for CDMA

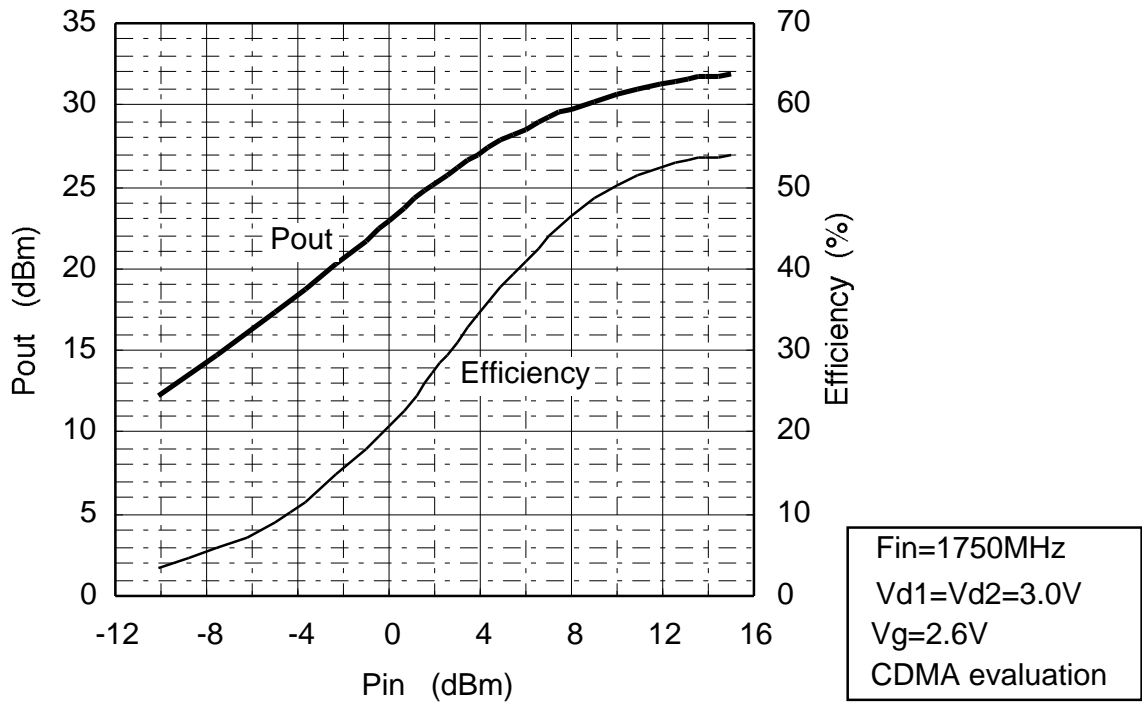

Preliminary
information

MGF7170AC

UHF BAND GaAs POWER AMPLIFIER

Pin vs. Pout, Gain for CDMA

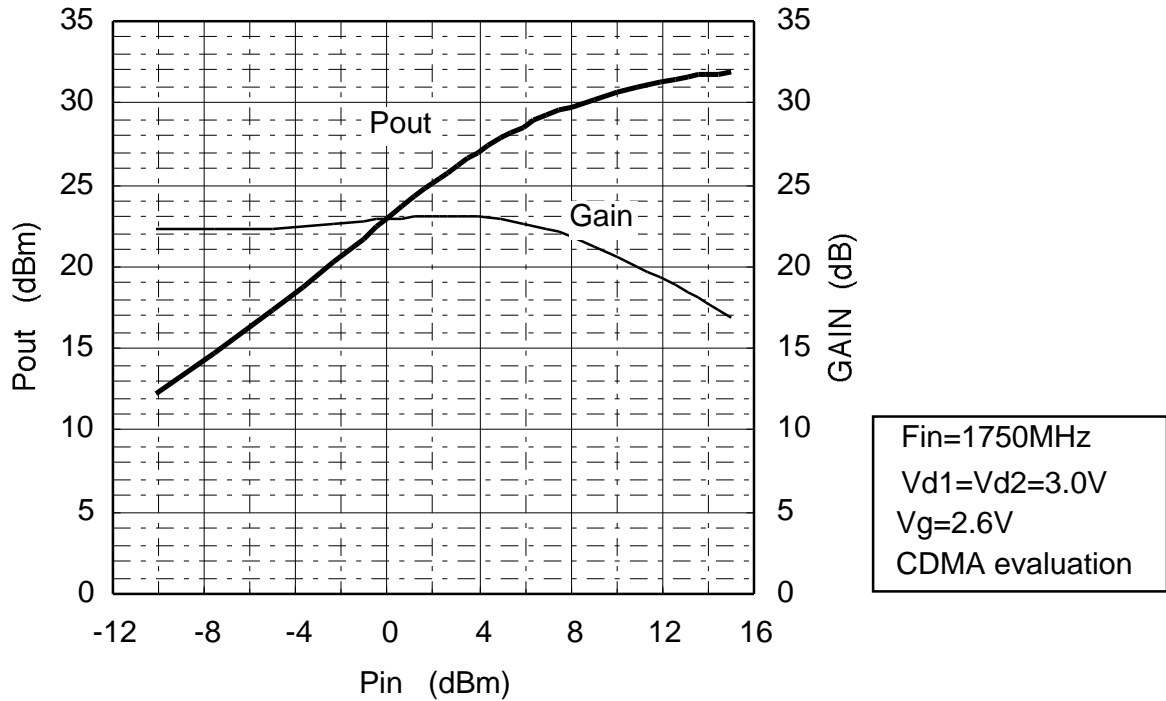

Pin vs. Pout, ACPR for CDMA

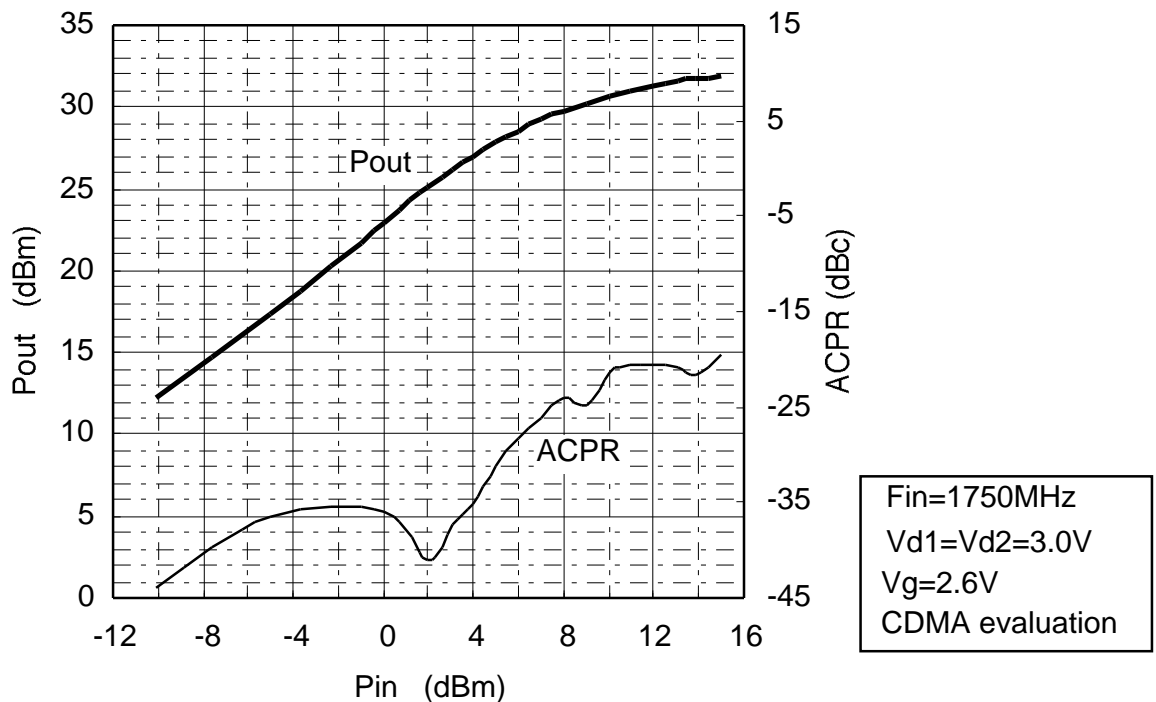

Preliminary information

MGF7170AC

UHF BAND GaAs POWER AMPLIFIER

Spectral Plot of CDMA

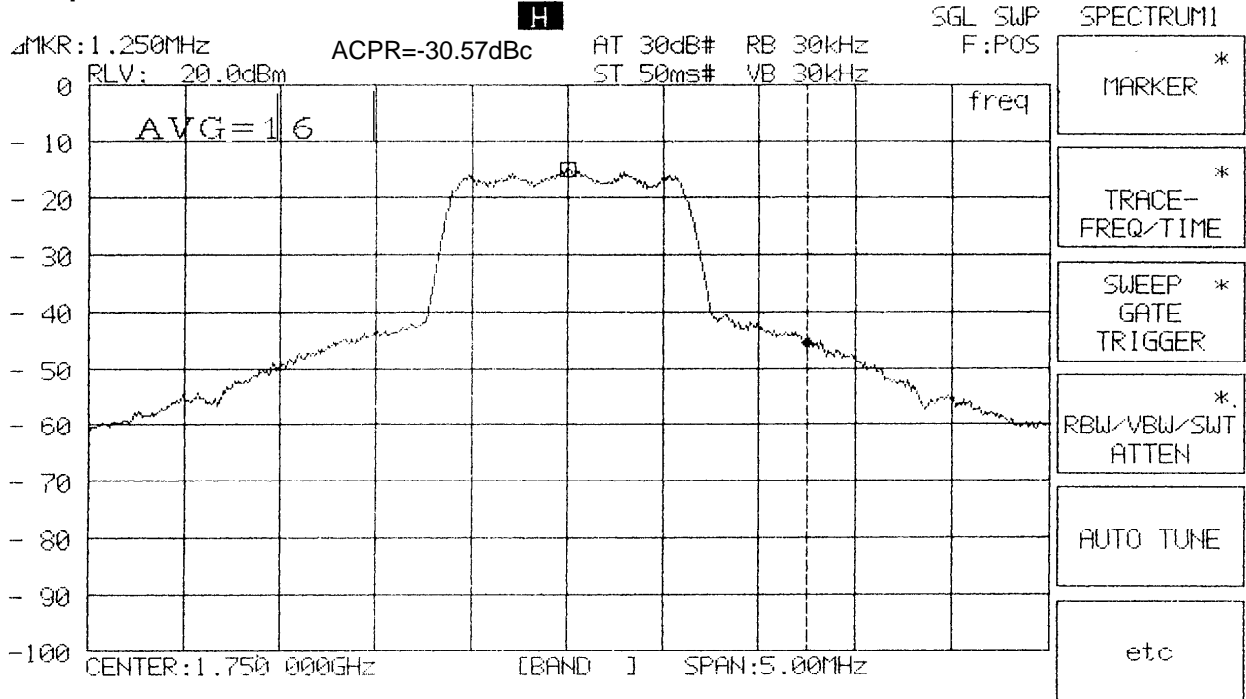

Harmonics

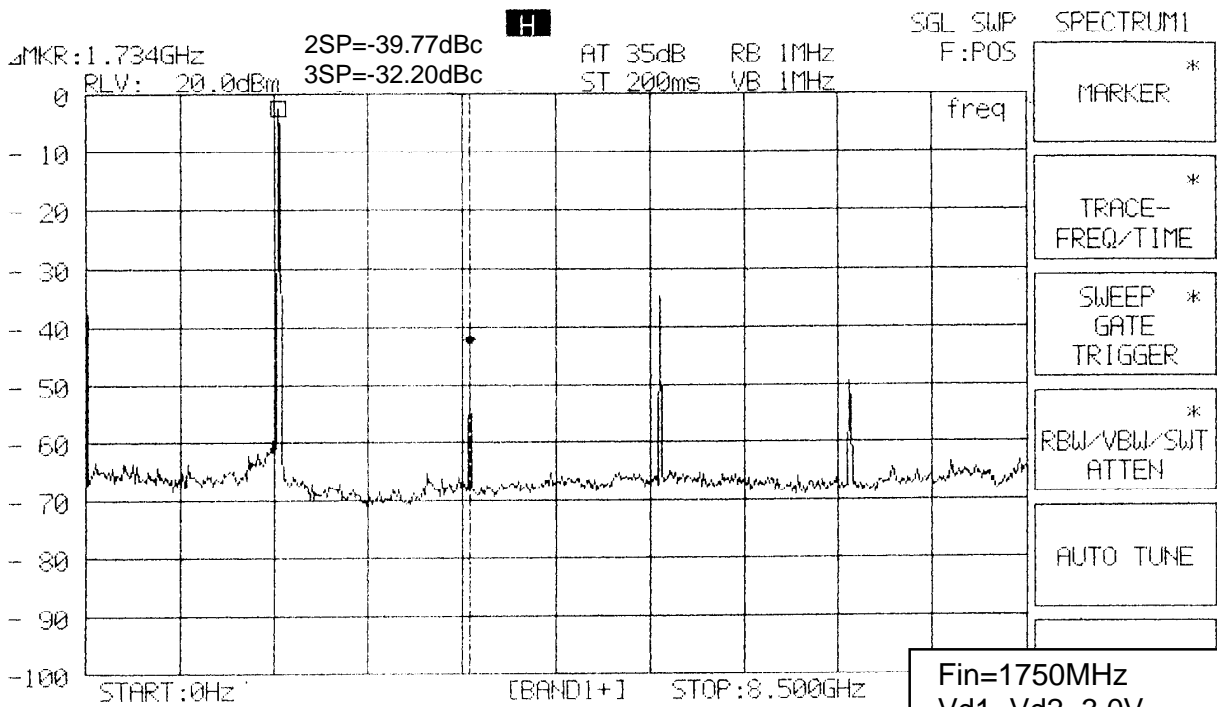

Fin=1750MHz
 Vd1=Vd2=3.0V
 Vg=2.6V
 Pout=28dBm
 CDMA evaluation

Preliminary information

MGF7170AC

UHF BAND GaAs POWER AMPLIFIER

Vd dependence of Pin vs.Pout,Idt

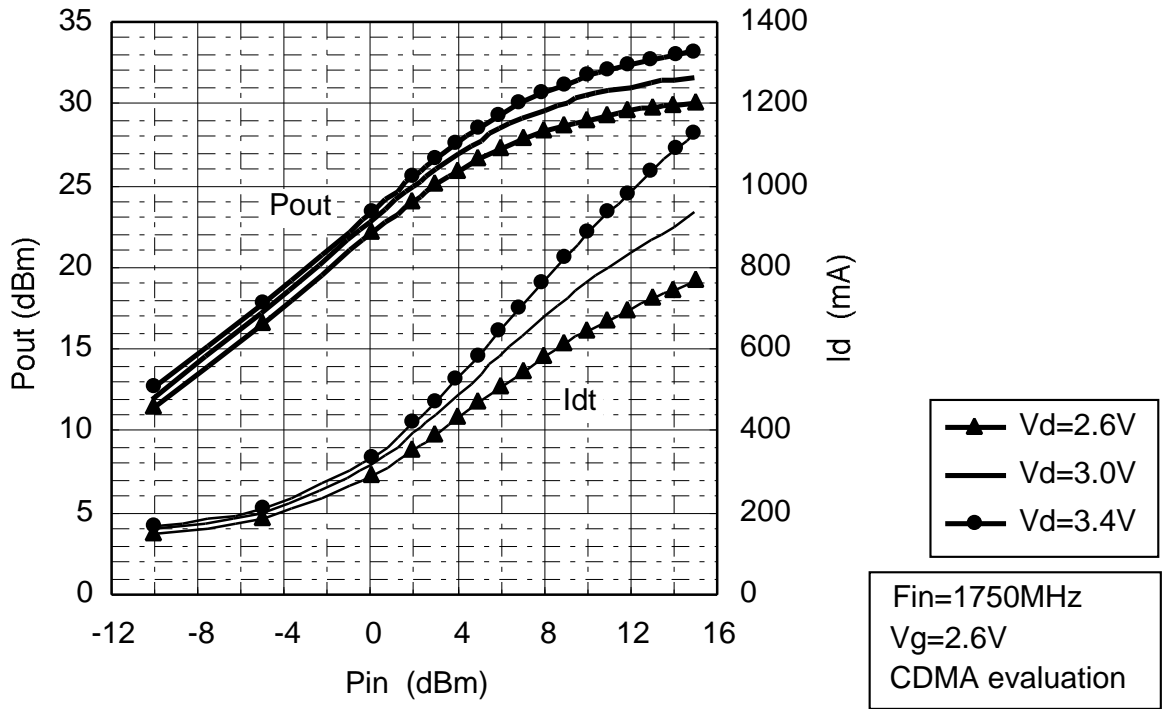

Vd dependence of Pin vs.Pout,Efficiency

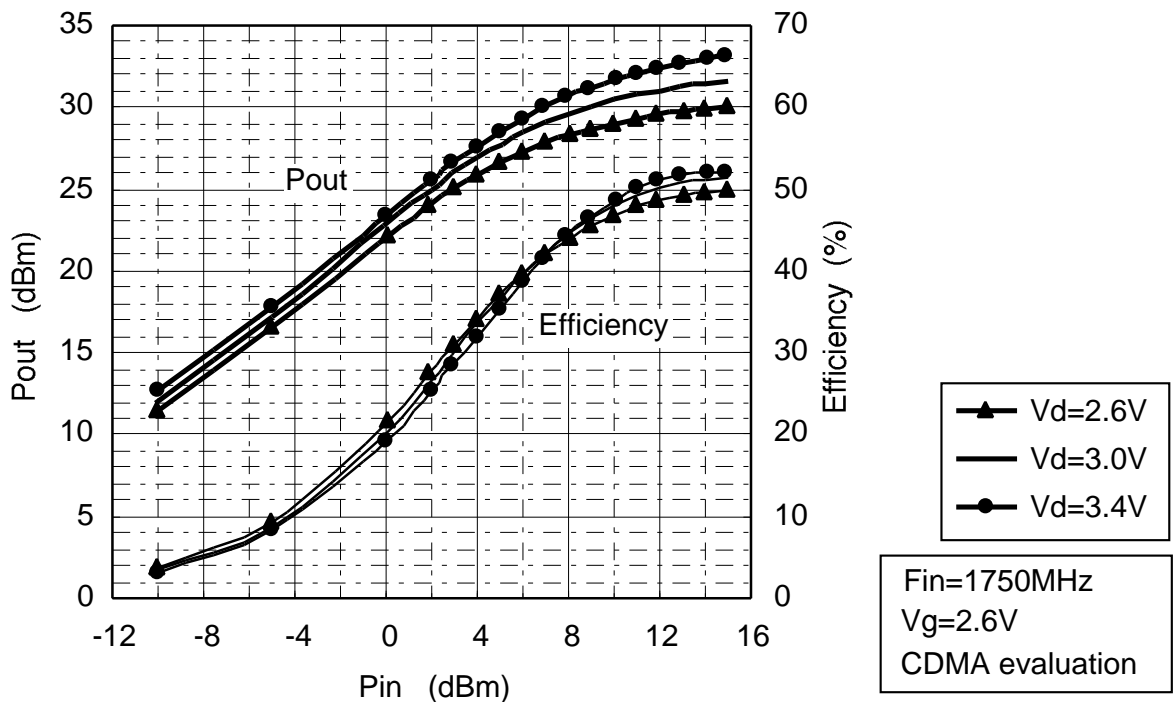

Preliminary
information

MGF7170AC

UHF BAND GaAs POWER AMPLIFIER

Vd dependence of Pin vs.Pout,Gain

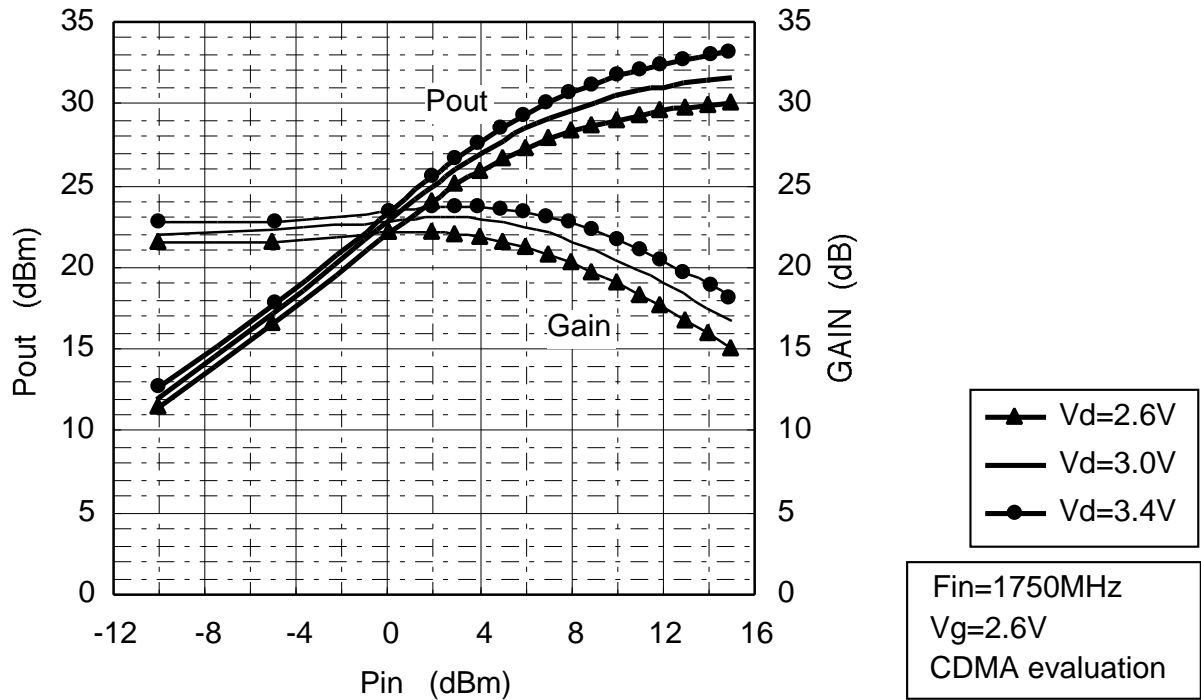

Vd dependence of Pin vs.Pout,ACPR

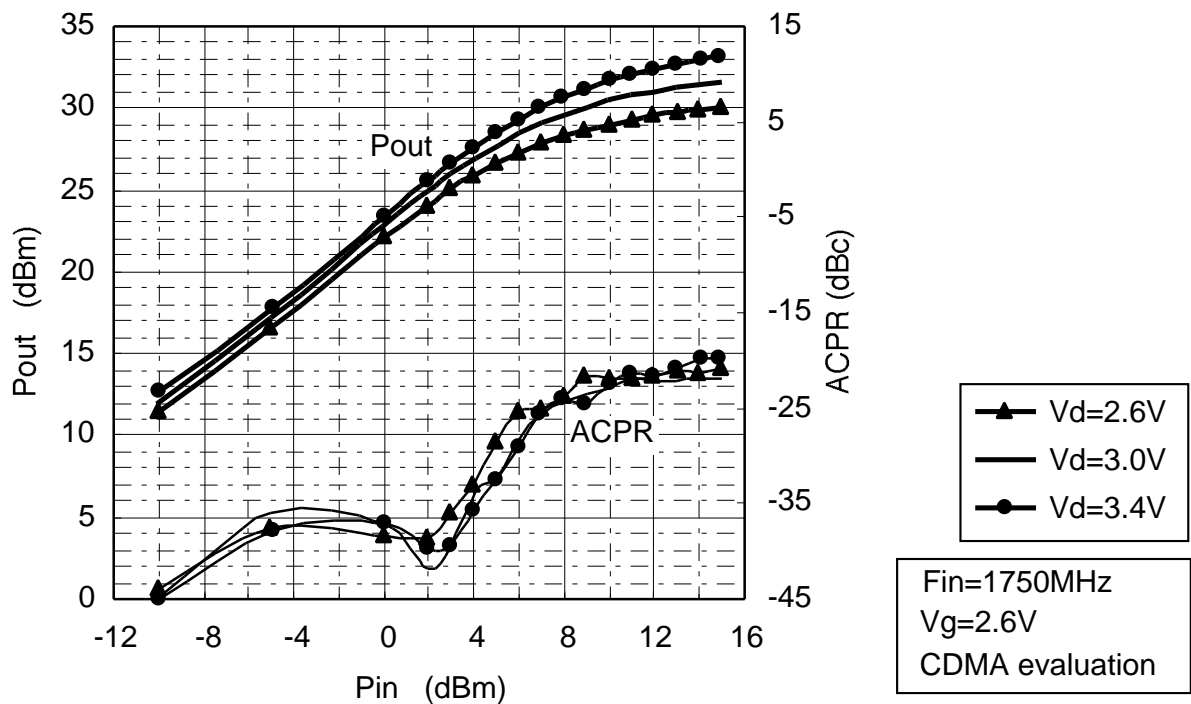

Preliminary information

MGF7170AC

UHF BAND GaAs POWER AMPLIFIER

Vd dependence of Fin vs. Gain, Idt

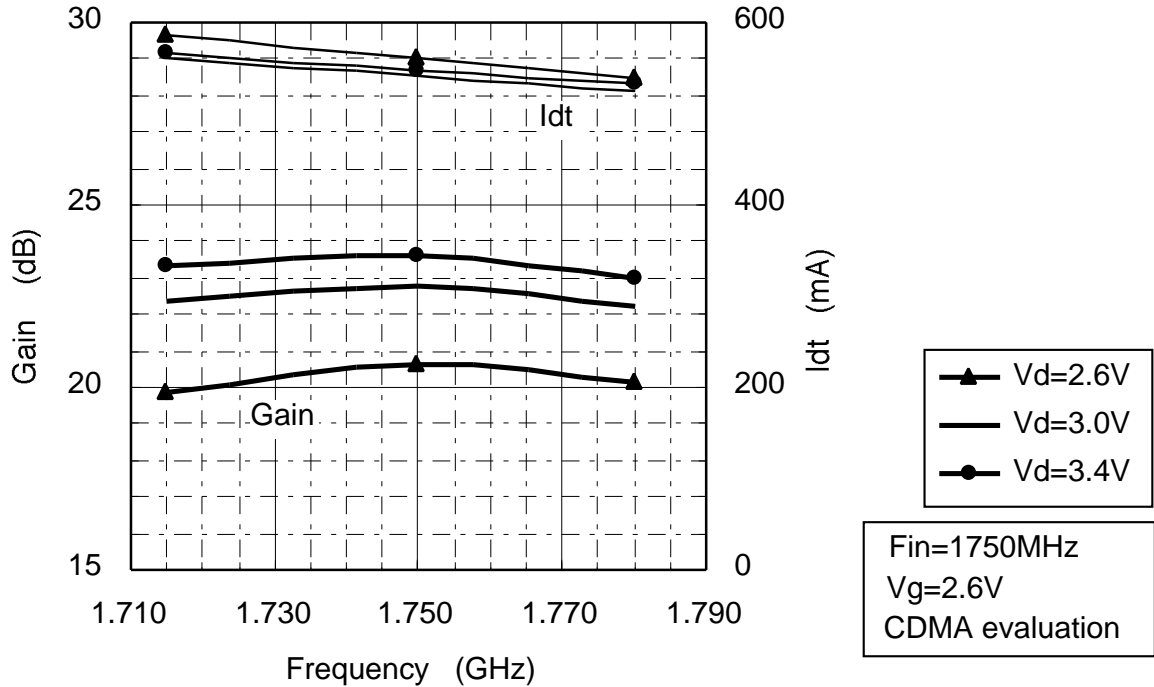

Vd dependence of Fin vs. Id1, Id2

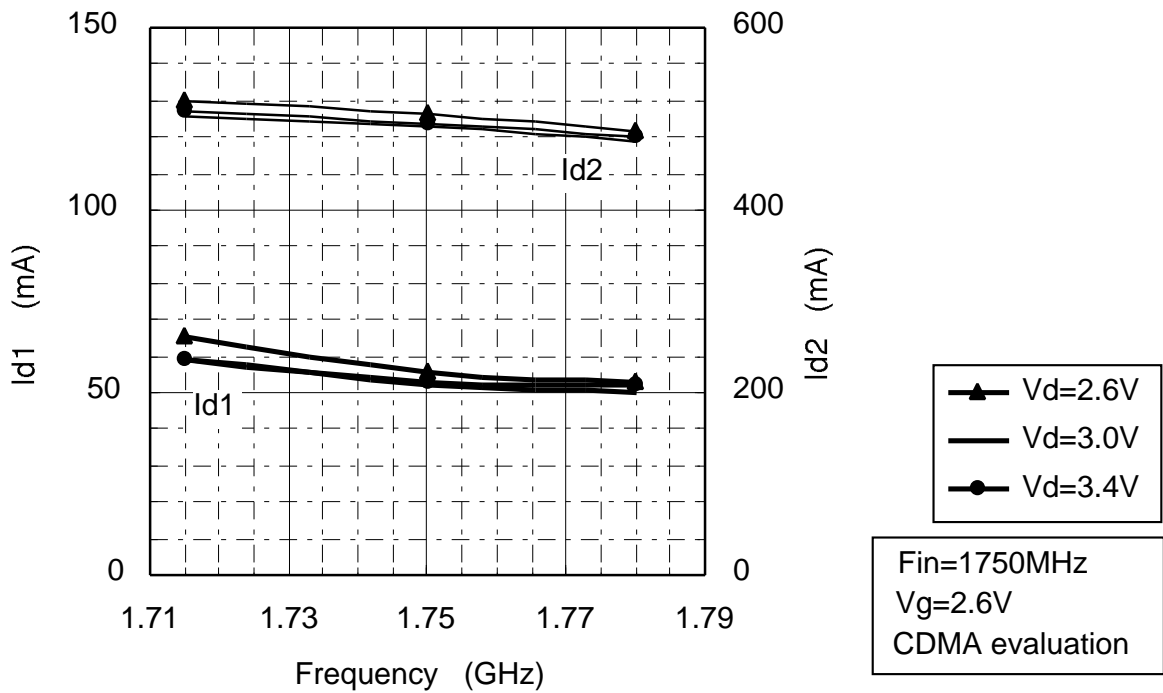

Vd dependence of Fin vs. Gain, Efficiency

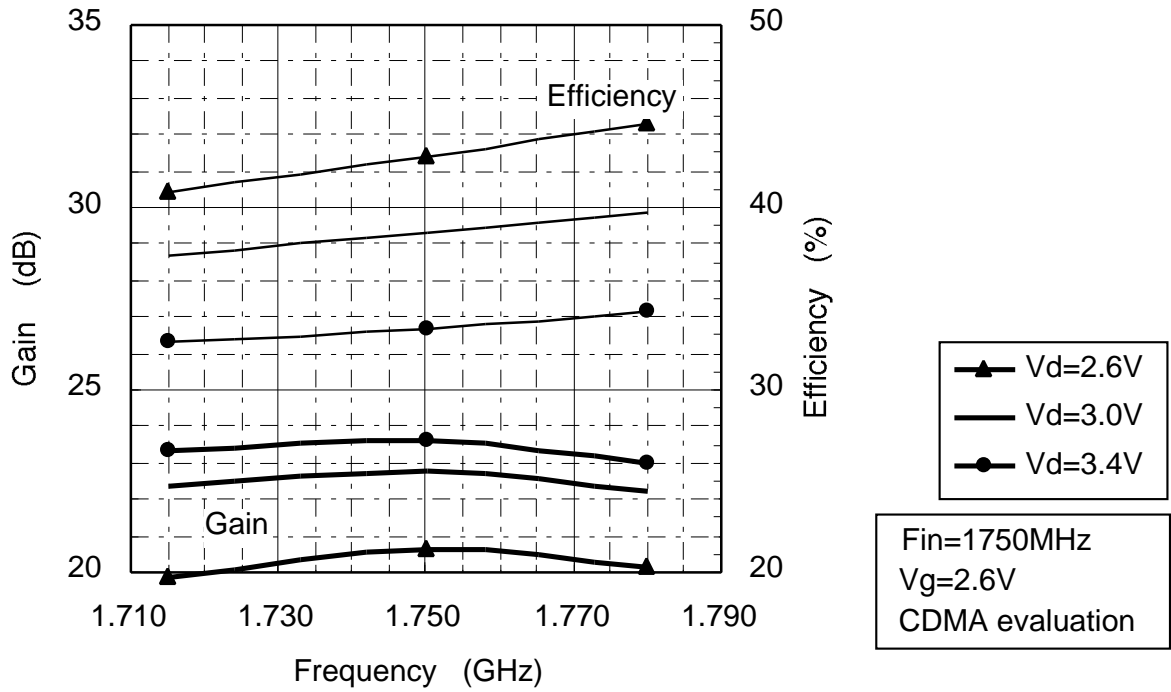

Vd dependence of Fin vs. Gain, ACPR

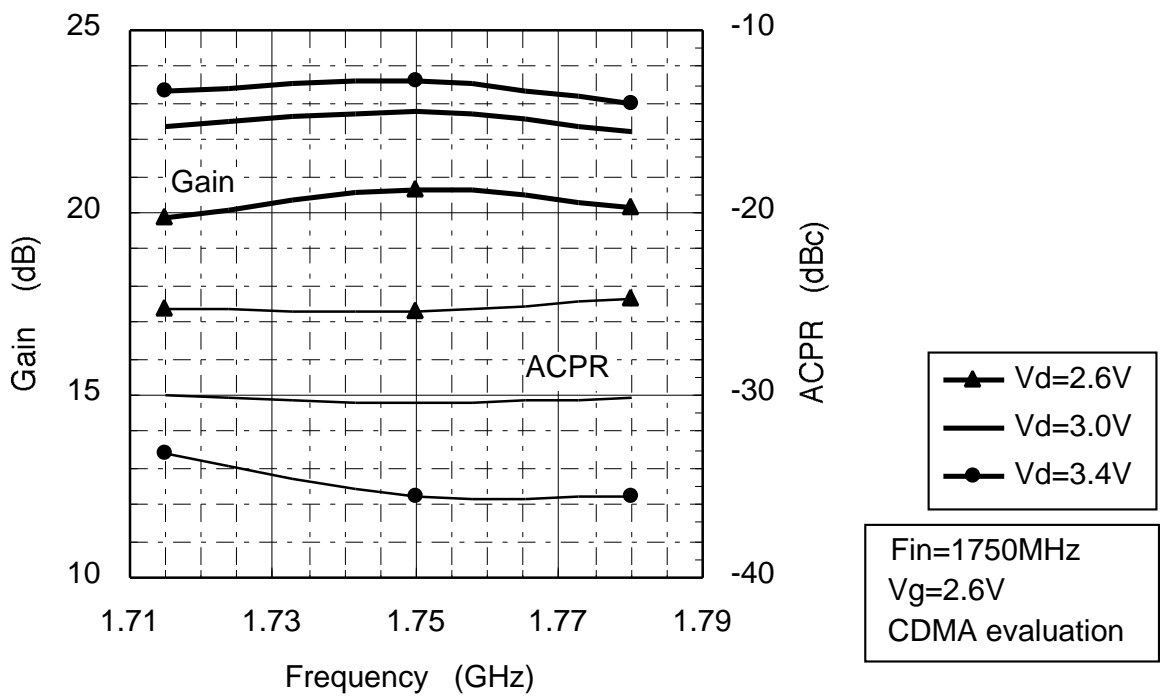

Preliminary
information

MGF7170AC

UHF BAND GaAs POWER AMPLIFIER

Equivalent Circuit of Test Board for CDMA(1.715-1.78GHz): ES1

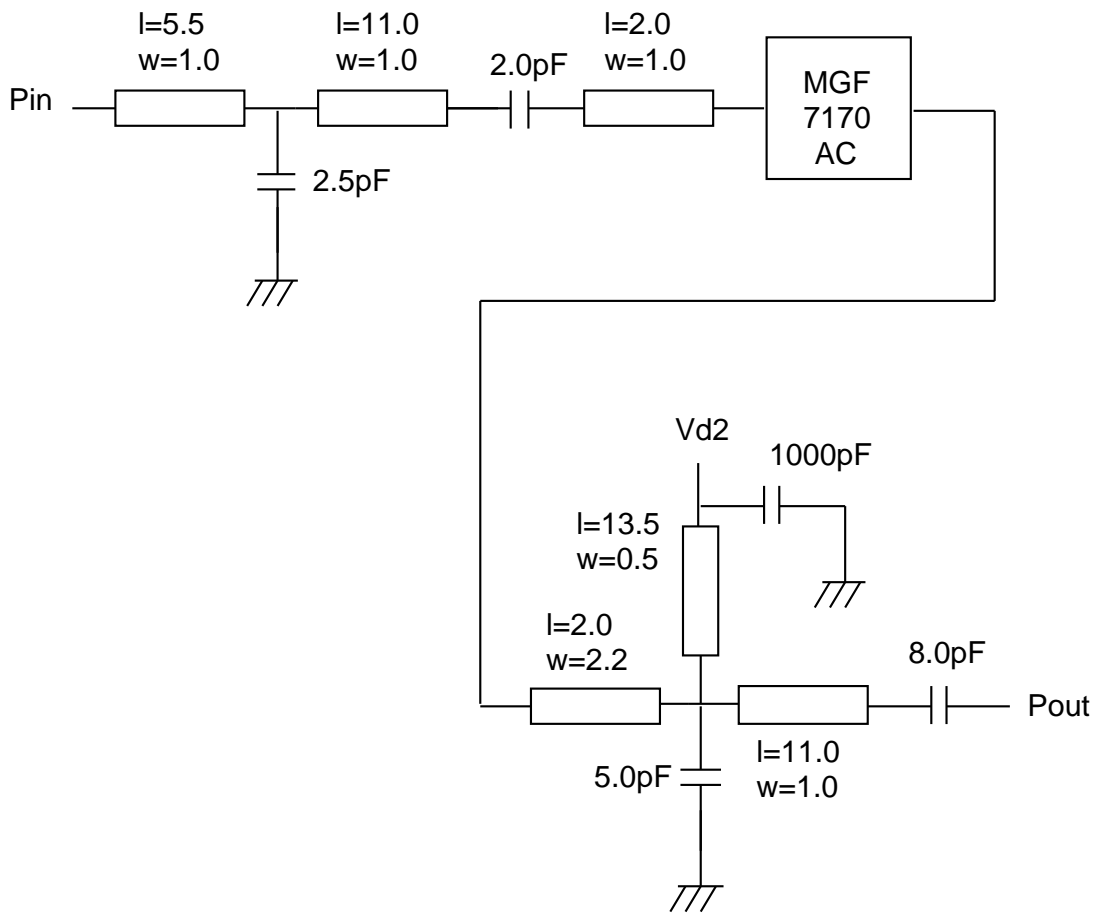

Unit:mm

SUB. data

Er=4.8

H=600 um

Metal T=43 um

Preliminary
information

MGF7170AC

UHF BAND GaAs POWER AMPLIFIER

Test Circuit Board for CDMA(1.715-1.78GHz): ES1

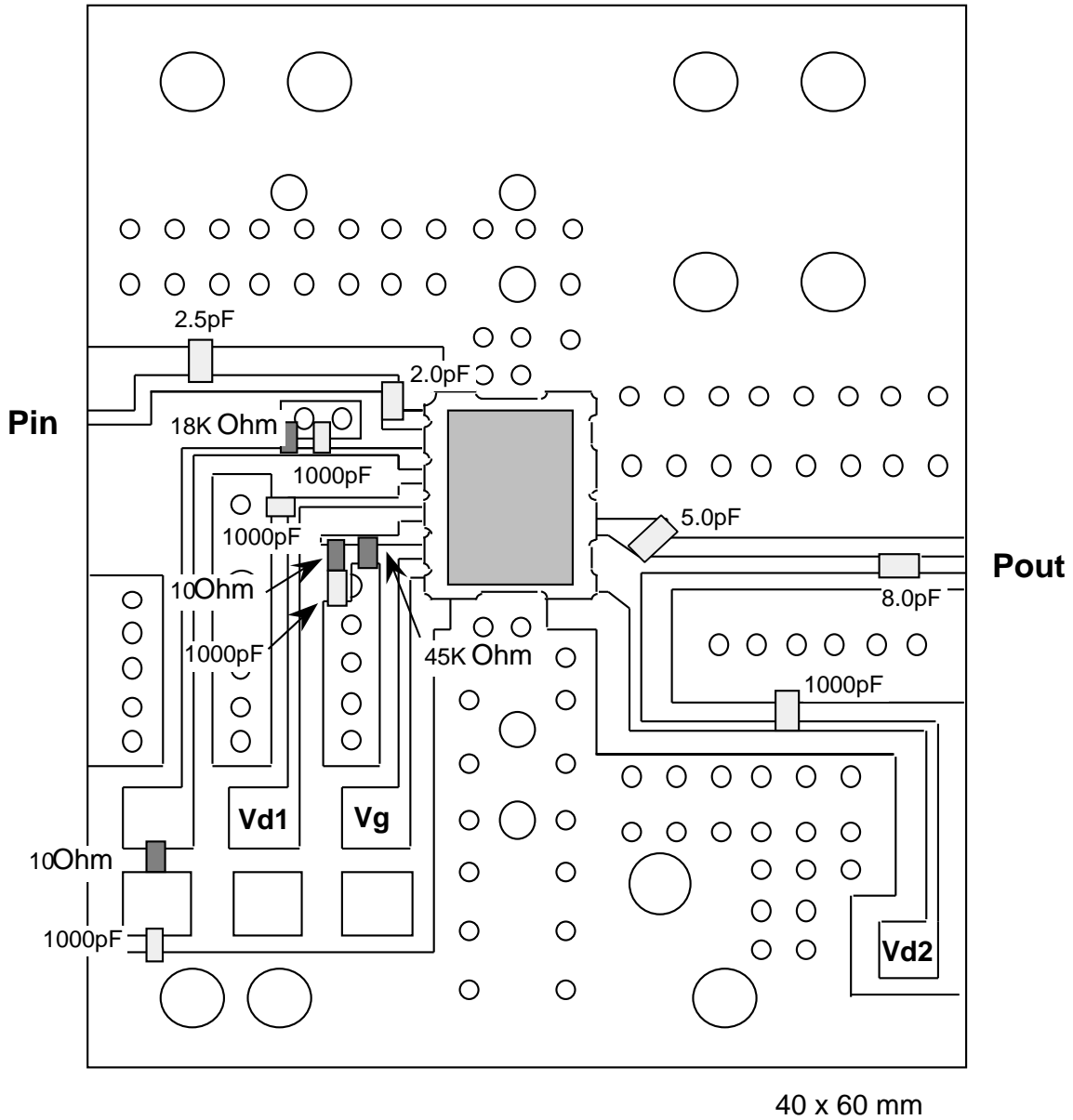

SUB. data
ER=4.8
H=600um
Metal T=43um

Preliminary
information

MGF7170AC

UHF BAND GaAs POWER AMPLIFIER

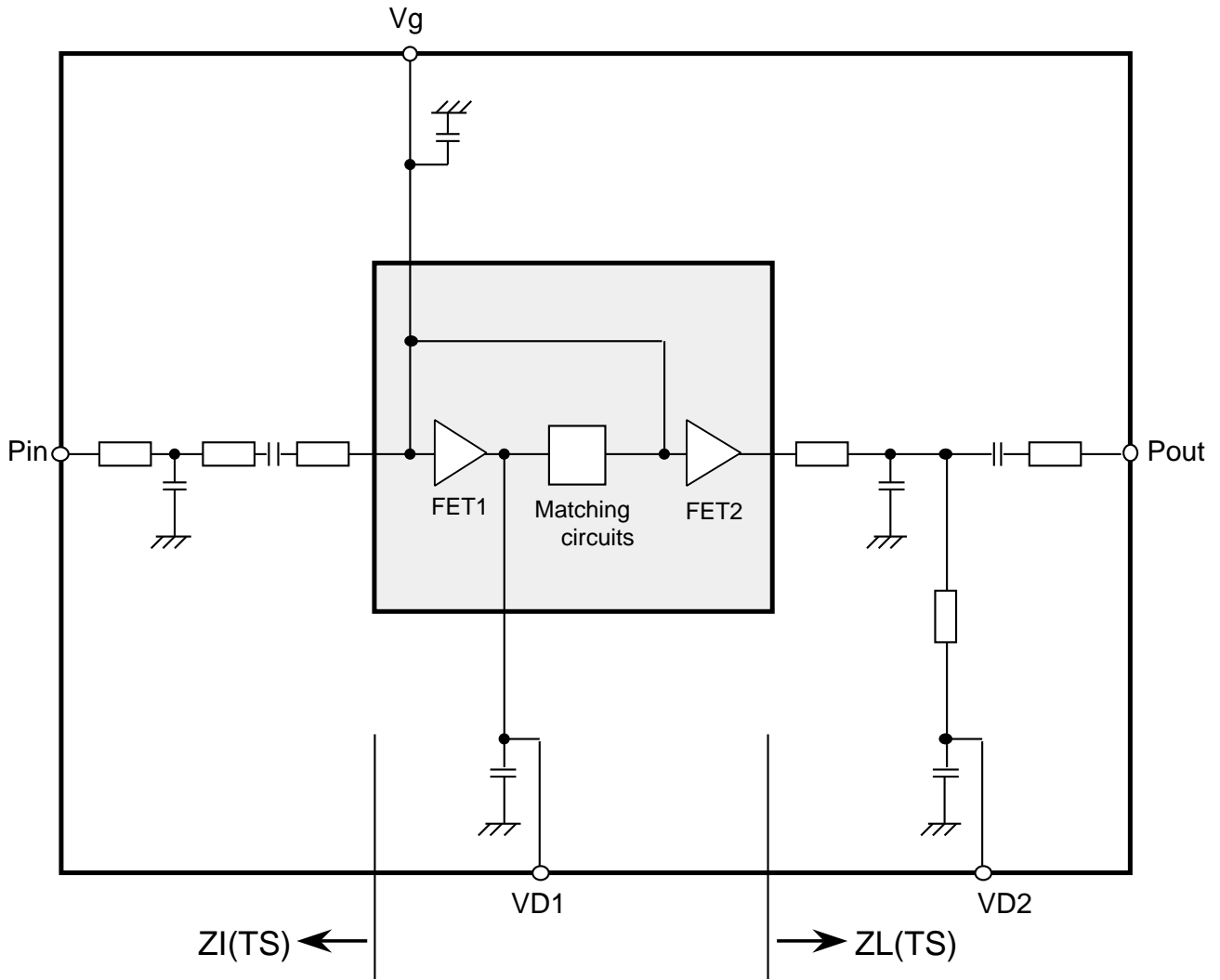

Equivalent circuit of MGF7170AC with our test board

- : MGF7170AC(Ceramic package)
- : our test board($\epsilon_r=4.8, t=0.6\text{mm}$)

Preliminary
information

MGF7170AC

UHF BAND GaAs POWER AMPLIFIER

Input/Output Impedance (@1.715-1.78GHz) : ES1

$$\begin{aligned} ZI(ES1) &= 8.7 - j18.3 () f=1.715\text{GHz} \\ &8.6 - j16.5 () f=1.75\text{GHz} \\ &8.5 - j15.0 () f=1.78\text{GHz} \end{aligned}$$

$$\begin{aligned} ZL(ES1) &= 3.8 - j1.1 () f=1.715\text{GHz} \\ &3.5 - j0.4 () f=1.75\text{GHz} \\ &3.3 + j 0.2 () f=1.78\text{GHz} \end{aligned}$$

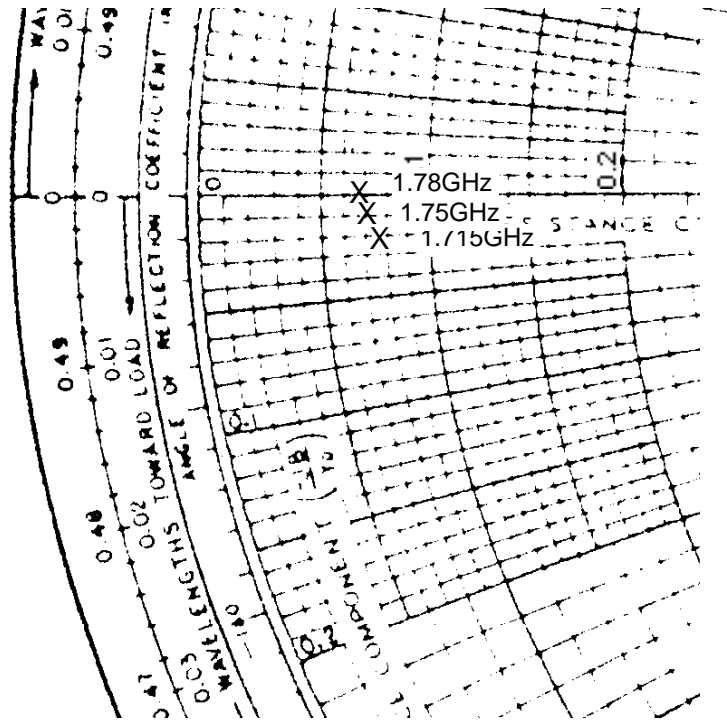

Conditions;
Vd1=Vd2=3.0V
Vg=2.6V
Pout=28dBm

Preliminary
information

MGF7170AC

UHF BAND GaAs POWER AMPLIFIER

Recommended Mount Pad

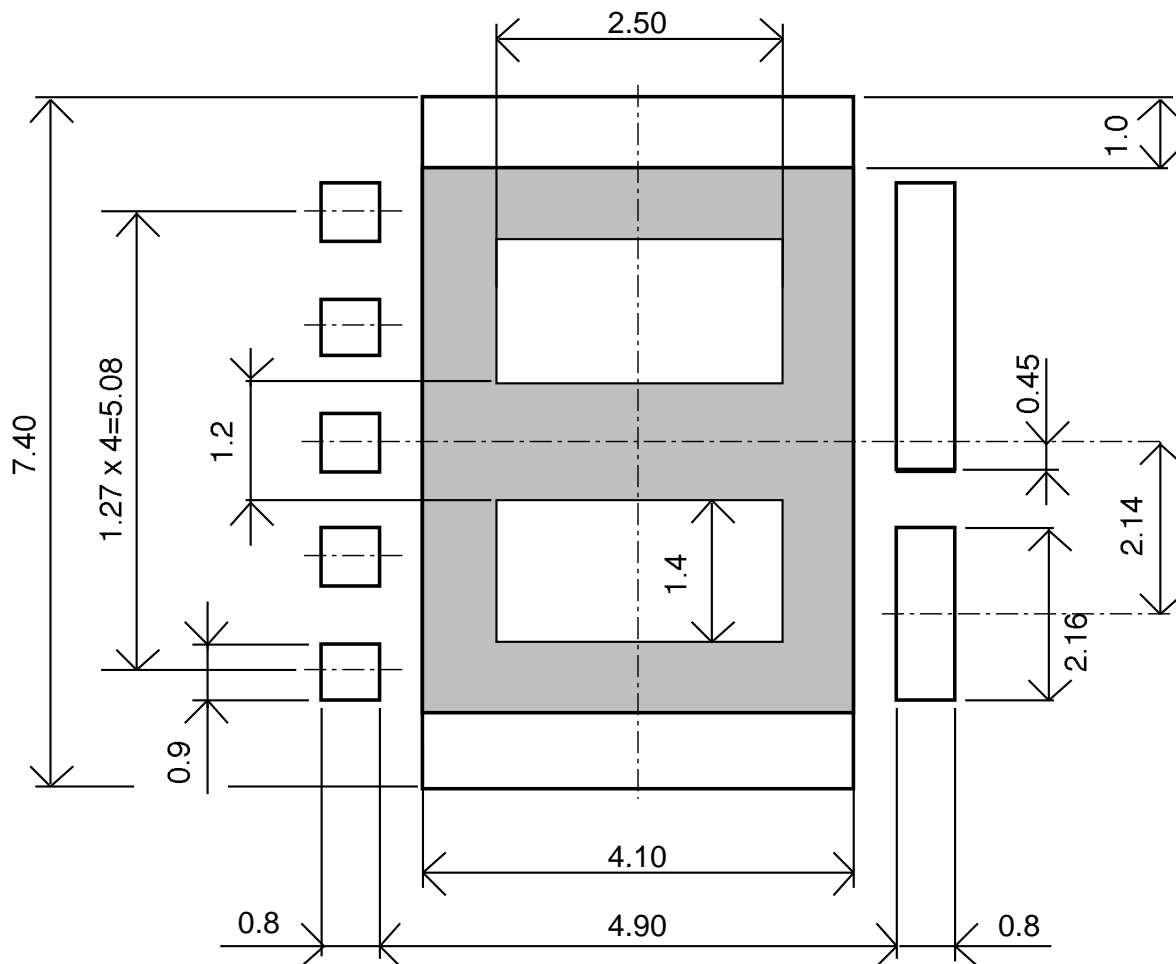

Unit:mm

Preliminary
information

MGF7170AC

UHF BAND GaAs POWER AMPLIFIER

Recommended Temperature Profile

1) Infrared Reflow and Air Reflow Temperature Profile

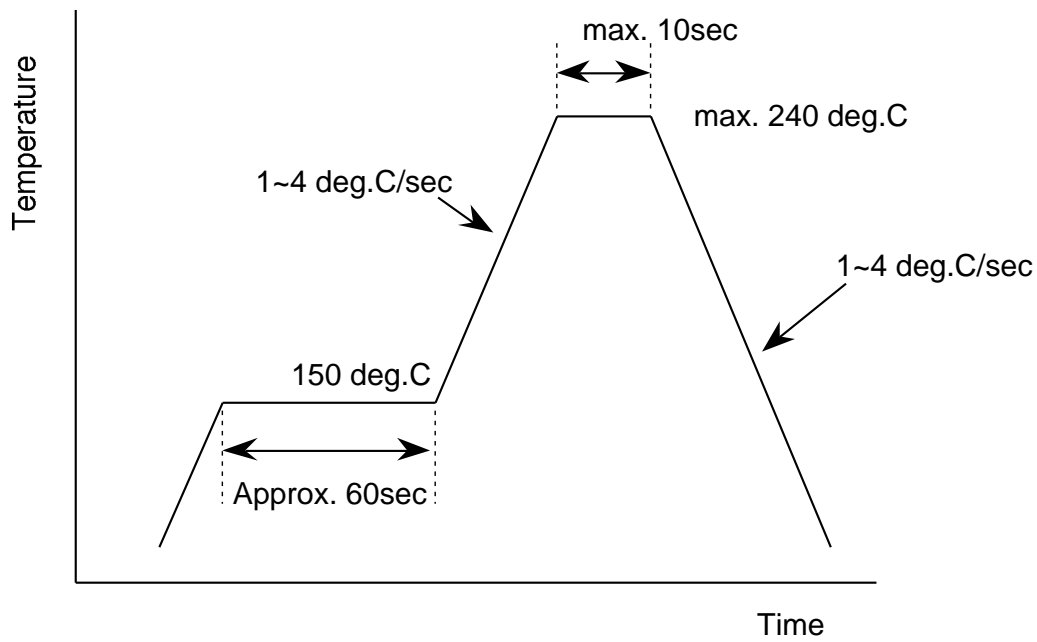

- Notes 1) Temperature profile on package surface
2) Reflow process : Up to three times