

LOW VOLTAGE HIGH CURRENT SMALL SIGNAL PNP TRANSISTOR

■ DESCRIPTION

The MMBT8550 is a low voltage high current small signal PNP transistor, designed for Class B push-pull audio amplifier and general purpose applications.

■ FEATURES

- *Collector current up to 1000mA
- *Collector-Emitter voltage up to 25 V
- *Complimentary to MMBT8050

■ ORDERING INFORMATION

Device	Package	Shipping [†]
MMBT8550	SOT-23 (Pb-Free)	3000 / Tape & Reel

[†]For information on tape and reel specifications, including part orientation and tape sizes, please refer to our Tape and Reel Packaging Specifications Brochure, BRD8011/D.

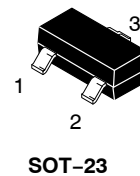
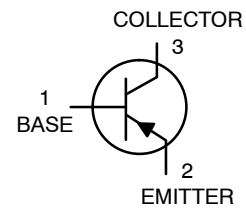

■ ABSOLUTE MAXIMUM RATINGS (Ta=25°C, unless otherwise specified)

PARAMETER		SYMBOL	RATING	UNITS
Collector-Base Voltage		V_{CBO}	-40	V
Collector-Emitter Voltage		V_{CEO}	-25	V
Emitter-Base Voltage		V_{EBO}	-5	V
Collector Current		I_C	-1000	mA
Collector Dissipation(Ta=25°C)	SOT-23	P_C	1	W
	TO-92		1	W
Junction Temperature		T_J	+150	°C
Storage Temperature		T_{STG}	-40 ~ +150	°C

Note: Absolute maximum ratings are those values beyond which the device could be permanently damaged.

Absolute maximum ratings are stress ratings only and functional device operation is not implied.

■ ELECTRICAL CHARACTERISTICS (Ta= 25°C, unless otherwise specified)

PARAMETER	SYMBOL	TEST CONDITIONS	MIN	TYP	MAX	UNIT
Collector-Base Breakdown Voltage	BV_{CBO}	$I_C=-100\mu A, I_E=0$	-40			V
Collector-Emitter Breakdown Voltage	BV_{CEO}	$I_C=-1mA, I_B=0$	-25			V
Emitter-Base Breakdown Voltage	BV_{EBO}	$I_E=-100\mu A, I_C=0$	-5			V
Collector Cut-off Current	I_{CBO}	$V_{CB}=-35V, I_E=0$			-100	nA
Emitter Cut-off Current	I_{EBO}	$V_{EB}=-5V, I_C=0$			-100	nA
DC Current Gain	h_{FE1}	$V_{CE}=-1V, I_C=-1mA$	100			
	h_{FE2}	$V_{CE}=-1V, I_C=-150mA$	120		400	
	h_{FE3}	$V_{CE}=-1V, I_C=-500mA$	40			
Collector-Emitter Saturation Voltage	$V_{CE(SAT)}$	$I_C=-800mA, I_B=-80mA$			-0.5	V
Base-Emitter Saturation Voltage	$V_{BE(SAT)}$	$I_C=-800mA, I_B=-80mA$			-1.2	V
Base-Emitter Saturation Voltage	V_{BE}	$V_{CE}=-1V, I_C=-10mA$			-1.0	V
Current Gain Bandwidth Product	f_T	$V_{CE}=-6V, I_C=-20mA$	150			MHz
Output Capacitance	C_{ob}	$V_{CB}=-10V, I_E=0, f=1MHz$		9.0		pF

■ CLASSIFICATION OF h_{FE2}

RANK	C	D	E
RANGE	120-200	160-300	280-400

■ TYPICAL CHARACTERISTICS

Static Characteristics

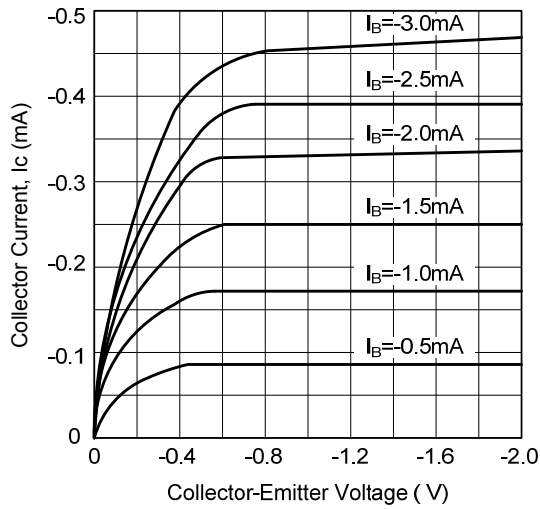

DC Current Gain

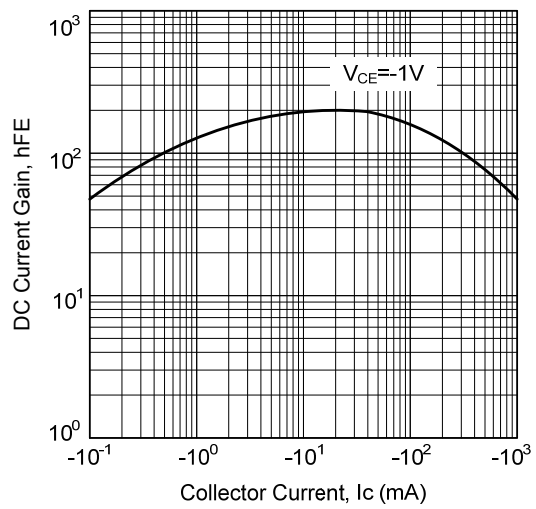

Base-Emitter on Voltage

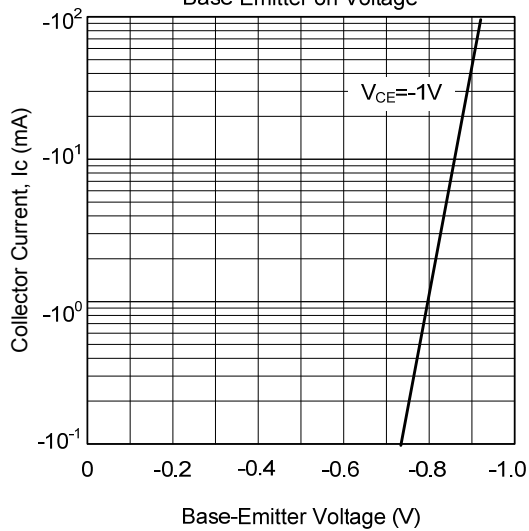

Saturation Voltage

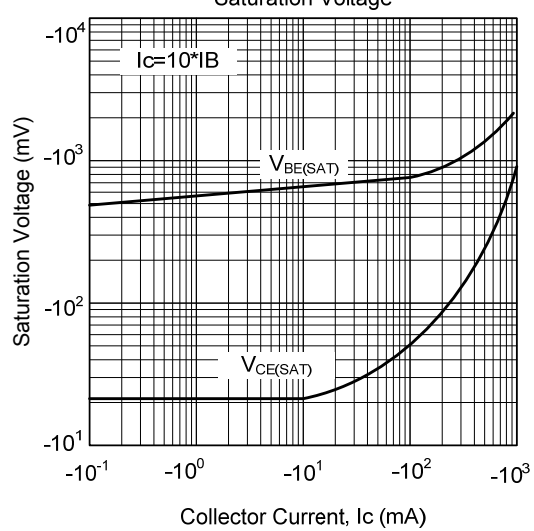

PACKAGE DIMENSIONS

SOT-23

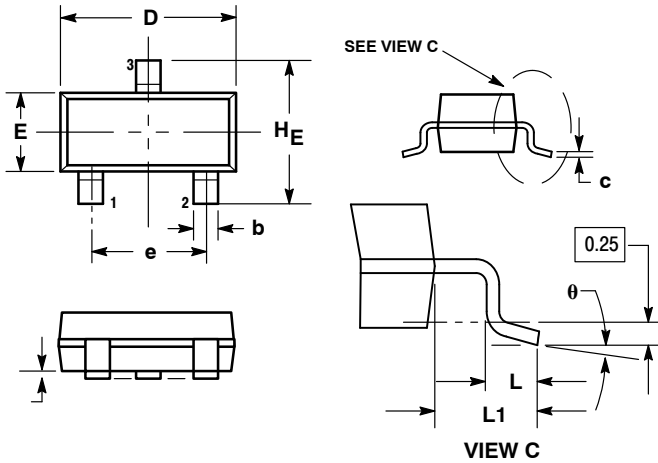

- NOTES:
1. DIMENSIONING AND TOLERANCING PER ANSI Y14.5M, 1982.
 2. CONTROLLING DIMENSION: INCH.
 3. MAXIMUM LEAD THICKNESS INCLUDES LEAD FINISH THICKNESS. MINIMUM LEAD THICKNESS IS THE MINIMUM THICKNESS OF BASE MATERIAL.
 4. DIMENSIONS D AND E DO NOT INCLUDE MOLD FLASH, PROTRUSIONS, OR GATE BURRS.

DIM	MILLIMETERS			INCHES		
	MIN	NOM	MAX	MIN	NOM	MAX
A	0.89	1.00	1.11	0.035	0.040	0.044
A1	0.01	0.06	0.10	0.001	0.002	0.004
b	0.37	0.44	0.50	0.015	0.018	0.020
c	0.09	0.13	0.18	0.003	0.005	0.007
D	2.80	2.90	3.04	0.110	0.114	0.120
E	1.20	1.30	1.40	0.047	0.051	0.055
e	1.78	1.90	2.04	0.070	0.075	0.081
L	0.10	0.20	0.30	0.004	0.008	0.012
L1	0.35	0.54	0.69	0.014	0.021	0.029
HE	2.10	2.40	2.64	0.083	0.094	0.104
θ	0°	---	10°	0°	---	10°

- STYLE 6:
 PIN 1. BASE
 2. EMITTER
 3. COLLECTOR

SOLDERING FOOTPRINT

