

Features

- Glass Passivated Die
- Low Forward Voltage Drop
- High Current Capability
- High Surge Current
- Low Leakage
- Anode To Tab Configuration

Maximum Ratings

- Operating Temperature: -65°C to +150°C
- Storage Temperature: -65°C to +175°C
- Thermal Resistance Junction to Case ($R_{\theta jc}$): 0.8°C/W

Part Number	Maximum Recurrent Peak Reverse Voltage	Maximum RMS Voltage	Maximum DC Blocking Voltage
MR2400FR	50V	35V	50V
MR2401FR	100V	70V	100V
MR2402FR	200V	140V	200V
MR2404FR	400V	280V	400V
MR2406FR	600V	420V	600V
MR2408FR	800V	560V	800V
MR2410FR	1000V	700V	1000V

TO-220

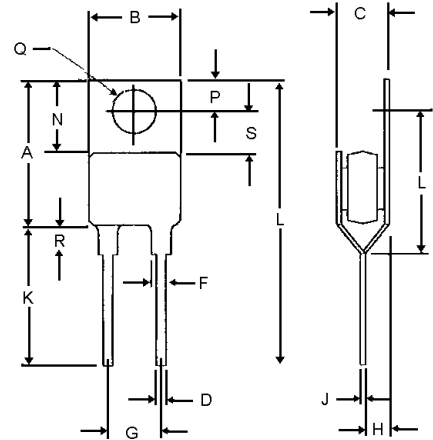

Electrical Characteristics @ 25°C Unless Otherwise Specified

Average Forward Current	$I_{F(AV)}$	24.0A	$T_c = 125^\circ\text{C}$
Peak Forward Surge Current	I_{FSM}	300A	8.3ms, half sine
Maximum Instantaneous Forward Voltage	V_F	1.15V	$I_{FM} = 24.0\text{A};$ $T_a \approx 25^\circ\text{C}^*$
Maximum DC Reverse Current At Rated DC Blocking Voltage	I_R	25 μA 1.0 μA	$T_c = 25^\circ\text{C}$ $T_c = 100^\circ\text{C}$
Maximum Reverse Recovery Time	T_{rr}	100ns to. 250ns.	$I_F = 0.5\text{A},$ $I_R = 1.0\text{A},$ $I_{rr} = 0.25\text{A}$
Typical Junction Capacitance	C_J	95pF	Measured at 1.0MHz, $V_R = 4.0\text{V}$

*Pulse test: Pulse width 300 μsec , Duty cycle 1%

MR2400FR thru MR2410FR

24 Amp Rectifier 50 - 1000 Volts

DIMENSIONS

DIM	INCHES		M M		NOTE
	MIN	MAX	MIN	MAX	
A	.560	.625	14.22	15.88	
B	.380	.420	9.65	10.67	
C	.284	.310	7.21	7.87	
D	.025	.045	0.64	1.14	
F	.060	.090	1.52	2.29	
G	.170	.210	4.32	5.33	
H	.080	.110	2.03	2.92	
J	.023	.029	0.58	0.74	
K	---	.562	---	14.27	
L	---	1.187	---	30.15	
N	.230	.270	5.84	6.86	
P	.100	.120	2.54	3.05	
Q	.139	.147	3.53	3.73	
R	---	.200	---	5.08	
S	.140	.150	3.55	3.80	
T	.670	.690	17.02	17.53	

FR2400FR thru FR2410FR

Figure 1
Typical Forward Characteristics

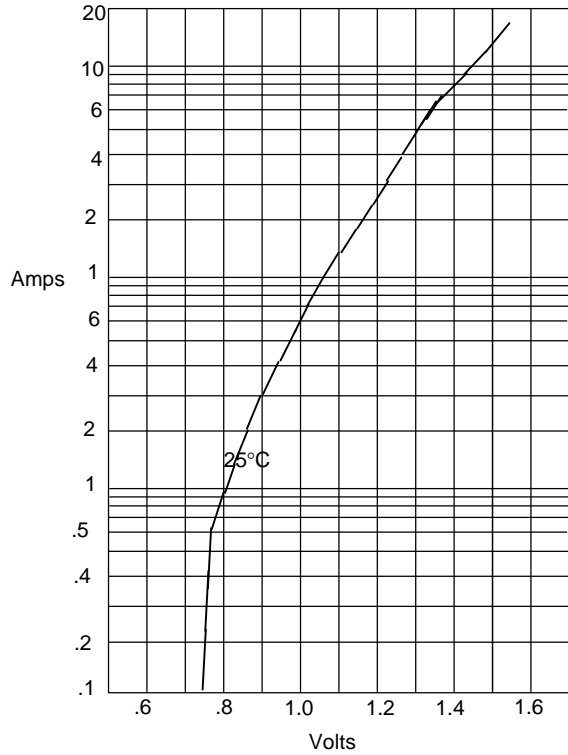

Instantaneous Forward Current - Amperes *versus*
Instantaneous Forward Voltage - Volts

Figure 2
Forward Derating Curve

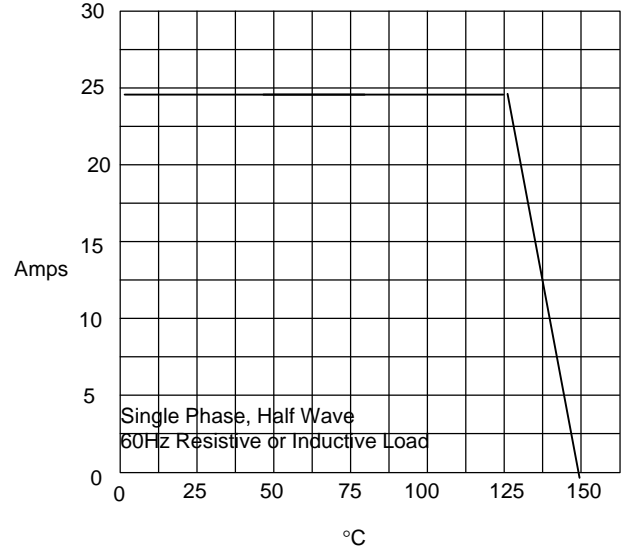

Average Forward Rectified Current - Amperes *versus*
Ambient Temperature - °C

Figure 3
Maximum Non-Repetitive Forward Surge Current

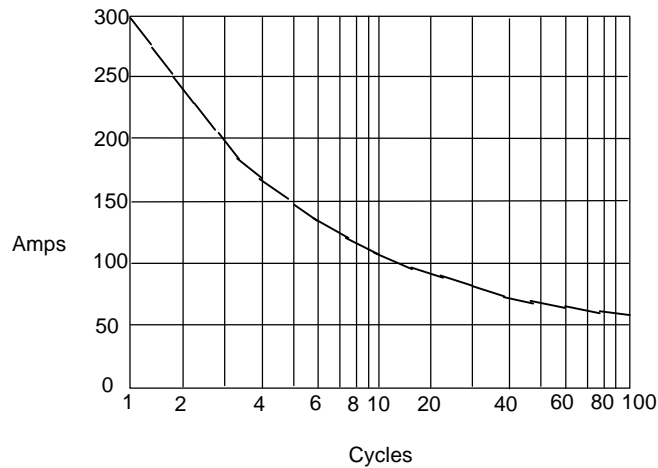

Peak Forward Surge Current - Amperes *versus*
Number Of Cycles At 60Hz - Cycles

Figure 4
Typical Reverse Characteristics

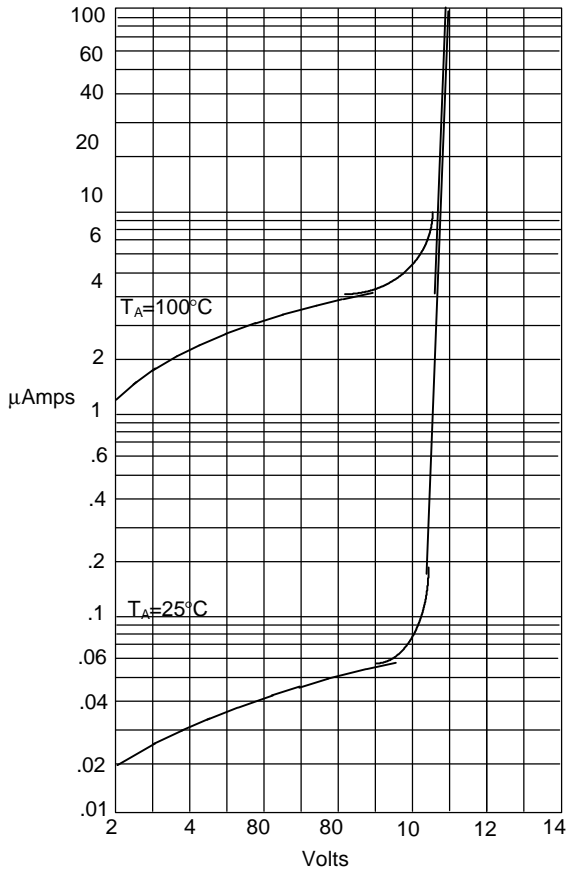

Instantaneous Reverse Leakage Current - MicroAmperes versus
Percent Of Rated Peak Reverse Voltage - Volts

Reverse Recovery Time Characteristic And Test Circuit Diagram

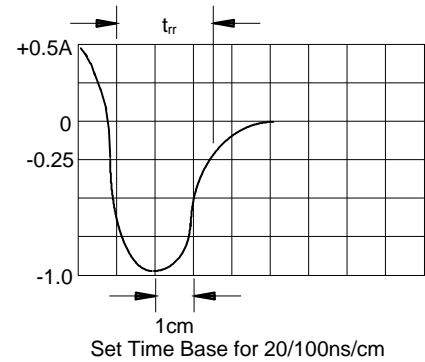
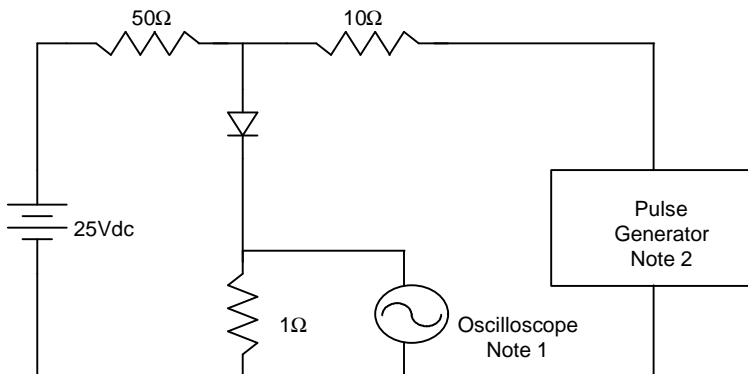

- Notes:
1. Rise Time = 7ns max.
Input impedance = 1 megohm, 22pF
 2. Rise Time = 10ns max.
Source impedance = 50 ohms
 3. Resistors are non-inductive