

Low-Voltage, Low R_{ON} , Single SPDT Analog Switch.

DESCRIPTION

The PA2011 is a low on-resistance, single-pole double-throw monolithic CMOS analog switch. It is designed for low voltage applications with guaranteed operation at 2 V.

The PA2011 is ideal for portable and battery powered equipment, requiring high performance and efficient use of board space. In addition to the low on-resistance (1.8Ω at 2.7 V), charge injection is less than 10 pC over the entire analog range.

The switch conducts equally well in both directions when on, and blocks up to the power supply level when off.

Break-before-make is guaranteed.

FEATURES

- Low Voltage Operation (1.8 V to 3.3 V)
- Low On-Resistance - r_{ON} : 1.8Ω at 2.7 V
- Low Charge Injection
- Low Voltage Logic Compatible
- SC-89 Package (1.6 x 1.6 mm)

BENEFITS

- Reduced Power Consumption
- Simple Logic Interface
- High Accuracy
- Reduce Board Space
- Guaranteed 2 V Operation

APPLICATIONS

- Cellular Phones
- Communication Systems
- Portable Test Equipment
- Battery Operated Systems
- Sample and Hold Circuits
- ADC and DAC Applications

FUNCTIONAL BLOCK DIAGRAM AND PIN CONFIGURATION

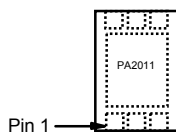
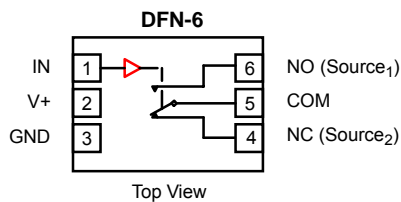

Device Marking: PA2011
xx Date Code

TRUTH TABLE

Logic	NC	NO
0	ON	OFF
1	OFF	ON

ORDERING INFORMATION

Temp Range	Package	Part Number
- 40 to 85 °C	SC-89 Tape and Reel	PA2011- T7
	SC-89 Lead (Pb)-free with Tape and Reel	PA2011-LF PA2011-LF-T7

ABSOLUTE MAXIMUM RATINGS $T_A = 25\text{ }^\circ\text{C}$, unless otherwise noted

Parameter	Symbol	Limit	Unit
Reference V_+ to GND		- 0.3 to + 3.3	V
IN, COM, NC, NO ¹		- 0.3 to ($V_+ + 0.3\text{ V}$)	
Continuous Current (NO, NC, COM pins)		± 150	mA
Peak Current (Pulsed at 1 ms, 10 % duty cycle)		± 300	
Storage Temperature	D Suffix	- 65 to 150	$^\circ\text{C}$
Power Dissipation (Packages) ²	SC-89 ³	172	mW

Notes:

1. Signals on NC, NO, or COM or IN exceeding V_+ will be clamped by internal diodes. Limit forward diode current to maximum current ratings.
2. All leads welded or soldered to PC Board.
3. Derate 2.15 mW/ $^\circ\text{C}$ above 70 $^\circ\text{C}$.

SPECIFICATIONS ($V_+ = 2.0\text{ V}$)

Parameter	Symbol	Test Conditions Otherwise Unless Specified $V_+ = 2.0\text{ V}$, $V_{IN} = 0.4\text{ V}$ or 1.6 V ⁵	Temp ¹	Limits - 40 to 85 $^\circ\text{C}$			Unit
				Min ²	Typ ³	Max ²	
Analog Switch							
Analog Signal Range ⁴	V_{NO} , V_{NC} , V_{COM}		Full	0		V_+	V
On-Resistance	r_{ON}	$V_+ = 2.0\text{ V}$, $V_{COM} = 0.2\text{ V}/0.9\text{ V}$ I_{NO} , $I_{NC} = 20\text{ mA}$	Room Full		3.5	5.5 5.5	Ω
Switch Off Leakage Current ⁵	$I_{NO(off)}$ $I_{NC(off)}$	$V_+ = 2.2\text{ V}$, V_{NO} , $V_{NC} = 0.5\text{ V}/1.5\text{ V}$, $V_{COM} = 1.5\text{ V}/0.5\text{ V}$	Room Full	- 1 - 10		1 10	nA
	$I_{COM(off)}$		Room Full	- 1 - 10		1 10	
Channel-On Leakage Current ⁶	$I_{COM(on)}$	$V_+ = 2.2\text{ V}$, V_{NO} , $V_{NC} = V_{COM} = 0.5\text{ V}/1.5\text{ V}$	Room	- 1 - 10		1 10	
Digital Control							
Input High Voltage	V_{INH}		Full	1.5			V
Input Low Voltage	V_{INL}		Full			0.4	
Input Capacitance	C_{in}		Full		4		pF
Input Current	I_{INL} or I_{INH}	$V_{IN} = 0$ or V_+	Full	1		1	μA
Dynamic Characteristics							
Turn-On Time	t_{ON}	V_{NO} or $V_{NC} = 1.5\text{ V}$, $R_L = 300\ \Omega$, $C_L = 35\text{ pF}$	Room Full		25	36 40	ns
Turn-Off Time	t_{OFF}		Room Full		10	15 16	
Break-Before-Make Time	t_{BBM}		Room	9	15		
Charge Injection ⁴	Q_{INJ}	$C_L = 1\text{ nF}$, $V_{GEN} = 0\text{ V}$, $R_{GEN} = 0\ \Omega$	Room		7		pC
Off-Isolation ⁴	OIRR	$R_L = 50\ \Omega$, $C_L = 5\text{ pF}$, $f = 1\text{ MHz}$	Room		- 113		dB
Crosstalk ⁴	X_{TALK}		Room		- 112		
N_O , N_C Off Capacitance ⁴	$C_{NO(off)}$ $C_{NC(off)}$	$V_{IN} = 0$ or V_+ , $f = 1\text{ MHz}$	Room		26		pF
Channel-On Capacitance ⁴	C_{ON}		Room		85		
Power Supply							
Positive Supply Range	V_+	$V_{IN} = 0$ or V_+		1.8		3.3	V
Negative Supply Current	I_+				0.01		1.0

SPECIFICATIONS (V+ = 3 V)							
Parameter	Symbol	Test Conditions Otherwise Unless Specified V+ = 3 V, ±10 %, V _{IN} = 0.4 V or 2.0 V ⁵	Temp ¹	Limits -40 to 85 °C			Unit
				Min ²	Typ ³	Max ²	
Analog Switch							
Analog Signal Range ⁴	V _{NO} , V _{NC} , V _{COM}		Full	0		V+	V
On-Resistance	r _{ON}	V+ = 2.7 V, V _{COM} = 0.9 V/1.5 V I _{NO} , I _{NC} = 50 mA	Room		1.8	2.7	Ω
r _{ON} Match	Δr _{ON}		Full			2.9	
r _{ON} Flatness	r _{ON} Flatness		Room		0.2	0.5	
Switch Off Leakage Current	I _{NO(off)} I _{NC(off)}	V+ = 3.3 V, V _{NO} , V _{NC} = 1 V/3 V, V _{COM} = 3 V/1 V	Room	- 1		1	nA
	I _{COM(off)}		Full	- 10		10	
Channel-On Leakage Current ⁶		I _{COM(on)}	Room	- 1		1	
	Full		- 10		10		
Digital Control							
Input High Voltage	V _{INH}		Full	1.6			V
Input Low Voltage	V _{INL}		Full			0.4	
Input Capacitance	C _{in}		Full		4		pF
Input Current	I _{INL} or I _{INH}	V _{IN} = 0 or V+	Full	1		1	μA
Dynamic Characteristics							
Turn-On Time	t _{ON}	V _{NO} or V _{NC} = 2.0 V, R _L = 300 Ω, C _L = 35 pF	Room		16	24	ns
Turn-Off Time	t _{OFF}		Full		7	9	
			Full		16		
Break-Before-Make Time	t _{BBM}		Room	7	9		
Charge Injection ⁴	Q _{INJ}	C _L = 1 nF, V _{GEN} = 0 V, R _{GEN} = 0 Ω	Room		2		pC
Off-Isolation ⁴	OIRR	R _L = 50 Ω, C _L = 5 pF, f = 1 MHz	Room		- 107		dB
Crosstalk ⁴	X _{TALK}		Room		- 107		
N _O , N _C Off Capacitance ⁴	C _{NO(off)} C _{NC(off)}	V _{IN} = 0 or V+, f = 1 MHz	Room		26		pF
	Channel-On Capacitance ⁴		C _{ON}	Room		84	
Power Supply							
Power Supply Range	V+			1.8		3.3	V
Power Supply Current	I+	V _{IN} = 0 or V+			0.01	1.0	μA
Power Consumption	P _C						3.3

Notes:

1. Room = 25 °C, Full = as determined by the operating suffix.
2. Typical values are for design aid only, not guaranteed nor subject to production testing.
3. The algebraic convention whereby the most negative value is a minimum and the most positive a maximum, is used in this data sheet.
4. Guarantee by design, nor subjected to production test.
5. V_{IN} = input voltage to perform proper function.
6. Guaranteed by 3.3V leakage testing, not production tested.

TYPICAL CHARACTERISTICS $T_A = 25\text{ }^\circ\text{C}$, unless otherwise noted

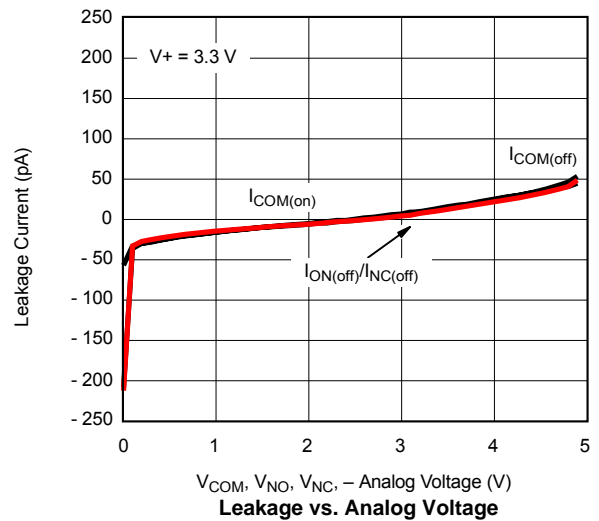
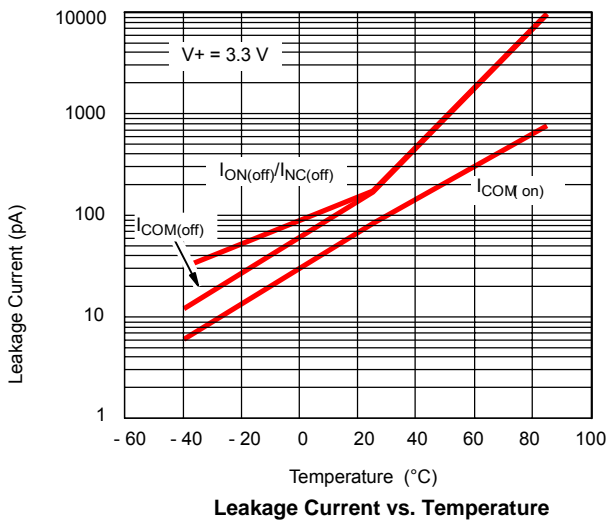
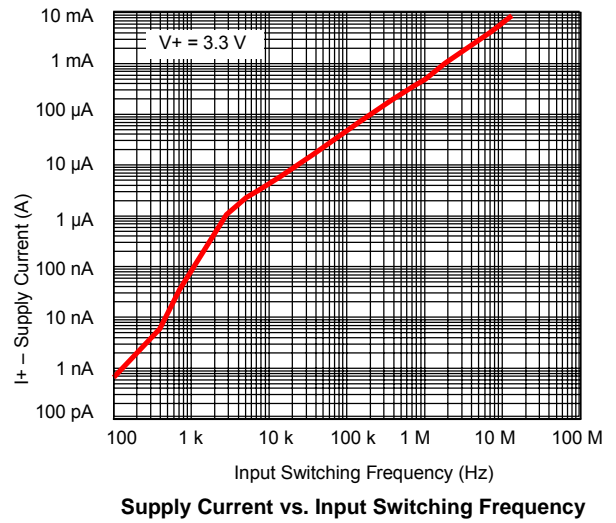
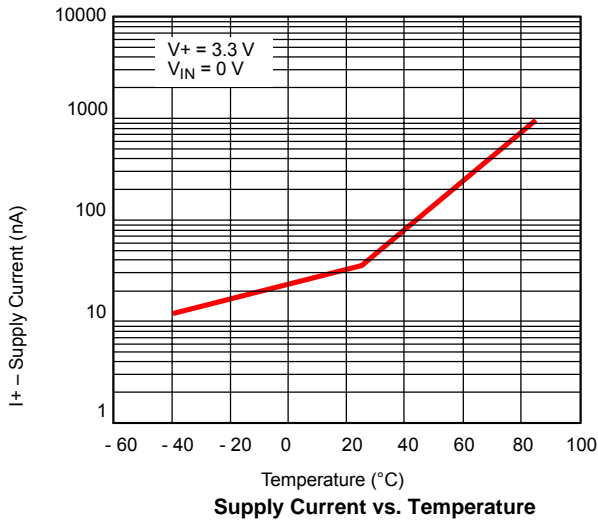
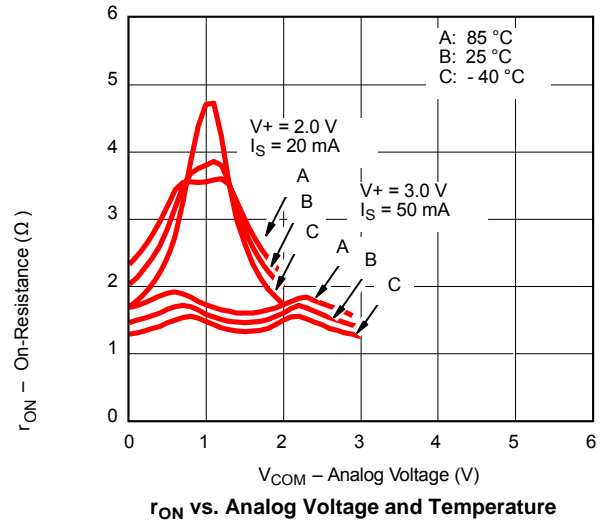
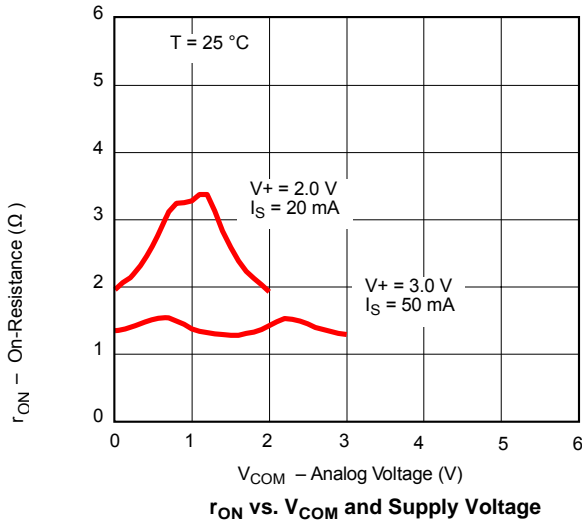

TYPICAL CHARACTERISTICS $T_A = 25\text{ }^\circ\text{C}$, unless otherwise noted

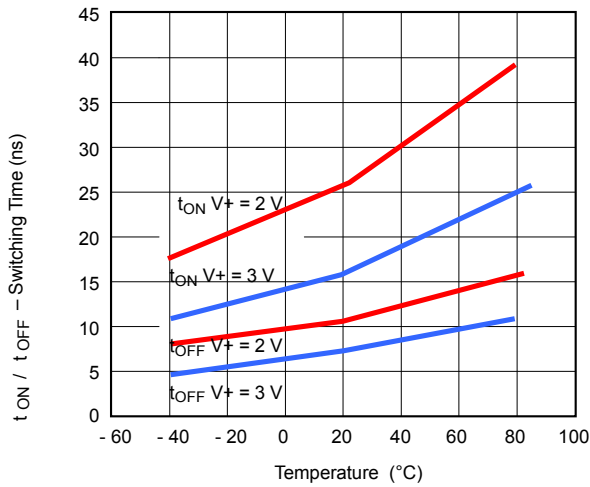

Switching Time vs. Temperature and Supply Voltage

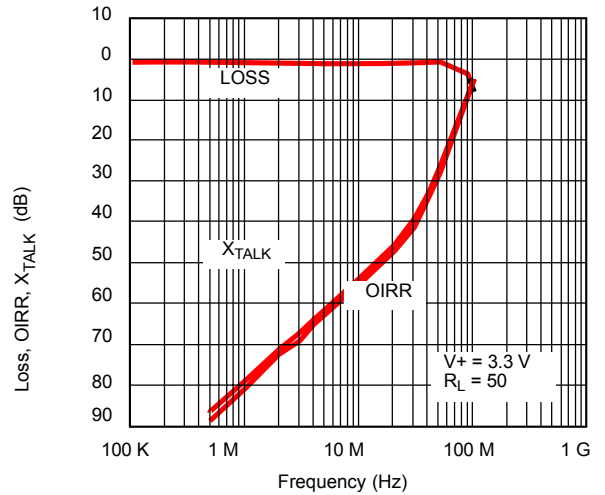

Insertion Loss, Off-Isolation, Crosstalk vs. Frequency

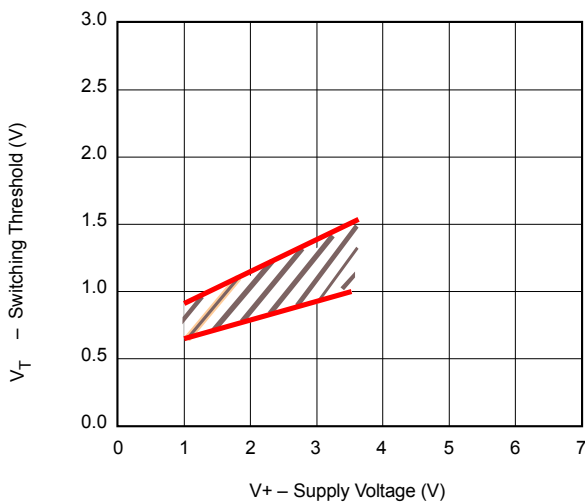

Switching Threshold vs. Supply Voltage

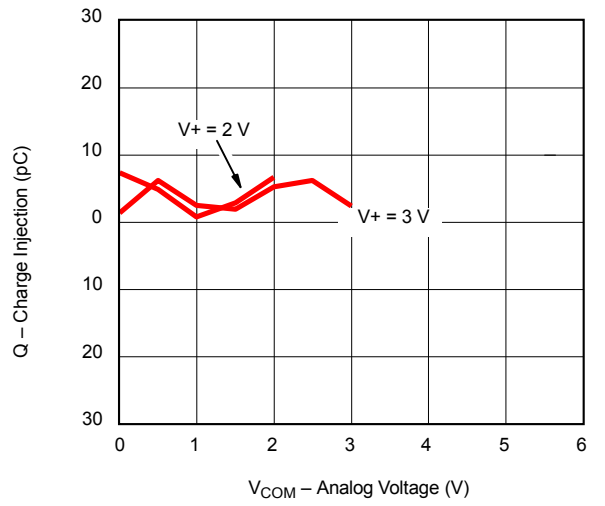

Charge Injection vs. Analog Voltage

TEST CIRCUITS

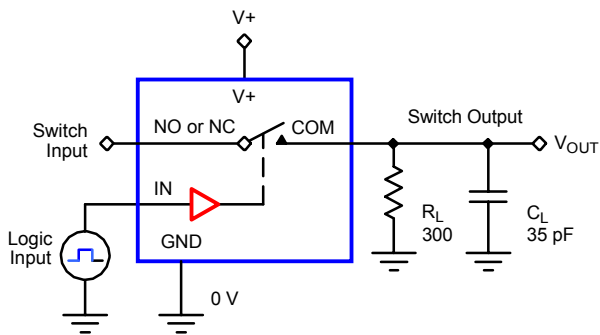

C_L (includes fixture and stray capacitance)

$$V_{OUT} = V_{COM} \left(\frac{R_L}{R_L + R_{ON}} \right)$$

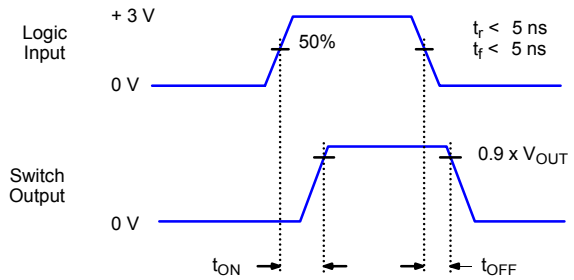

Logic "1" = Switch On
Logic input waveforms inverted for switches that have the opposite logic sense.

Figure 1. Switching Time

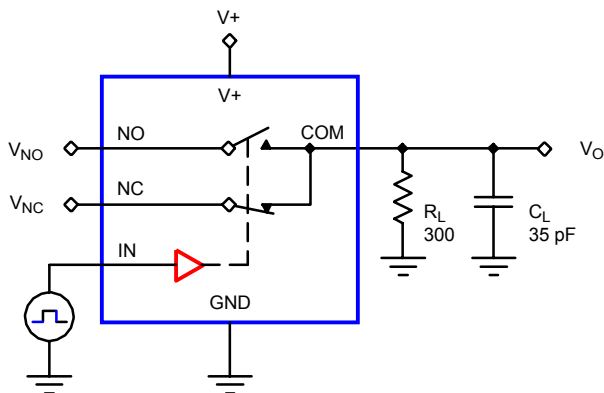

C_L (includes fixture and stray capacitance)

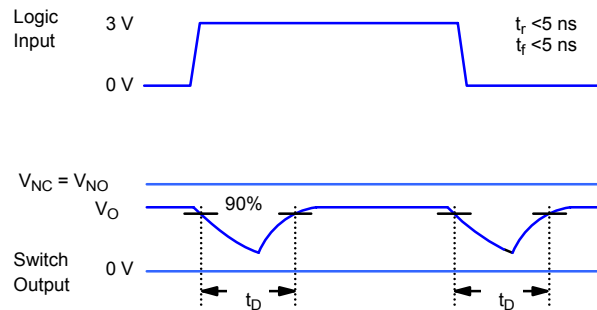

Figure 2. Break-Before-Make Interval

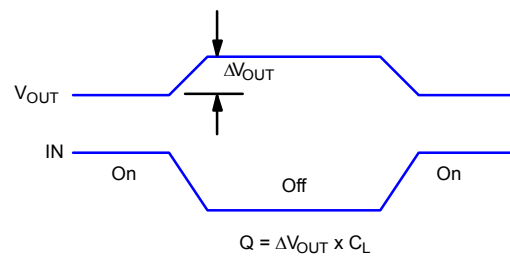
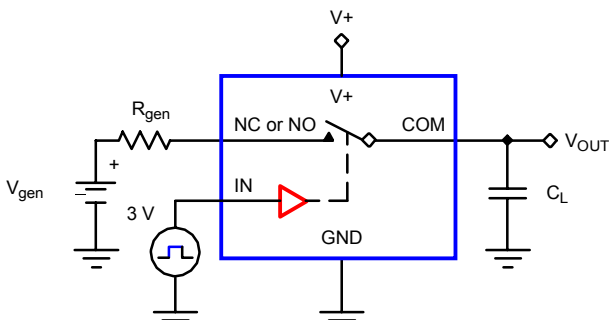

Figure 3. Charge Injection

IN depends on switch configuration: input polarity determined by sense of switch.

TEST CIRCUITS

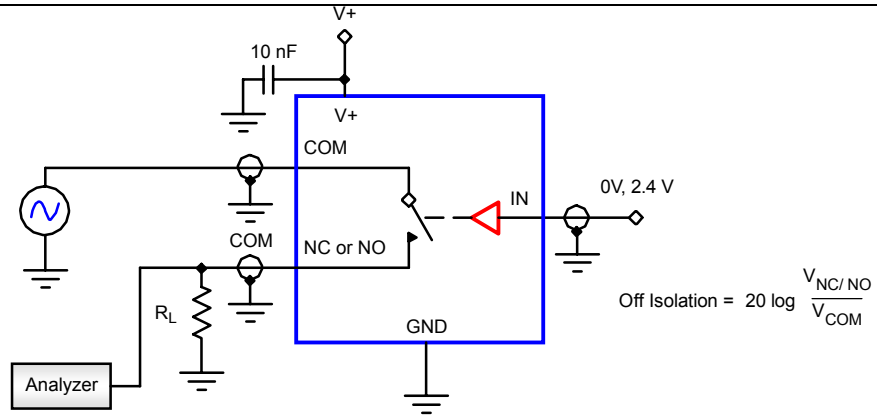

Figure 4. Off-Isolation

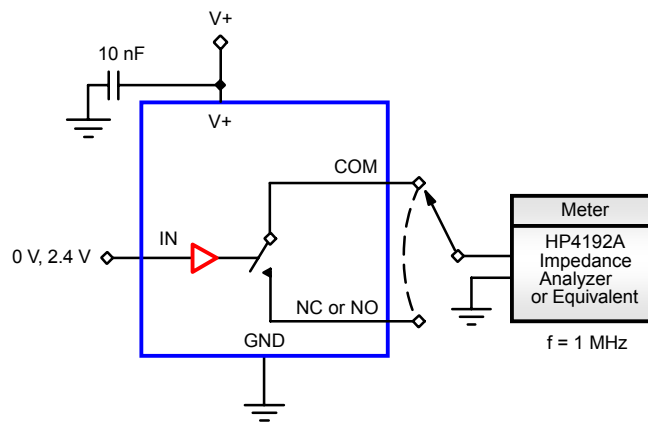

Figure 5. Channel Off/On Capacitance

TYPICAL APPLICATIONS

