

**PAW3603DH-NF LOW POWER WIRELESS LASER MOUSE SENSOR**
**General Description**

The PAW3603DH-NF is a low power CMOS process wireless laser mouse sensor with DSP integration chip that serves as a non-mechanical motion estimation engine for implementing a computer mouse.

**Features**

- Single power supply
- Precise laser motion estimation technology
- Complete 2-D motion sensor
- No mechanical parts
- Accurate motion estimation over most of surfaces
- High speed motion detection up to 20 inches/sec
- High resolution up to 2000 CPI
- Resolution setting by two method
  - ✧ CPI IO trap select pin (pin15) to 800, 1200, 1600 CPI
  - ✧ Register setting to 800/1000/1200/1600/2000 CPI
- Power down pin and register setting for low power dissipation
- Power saving mode during times of no movement
- Serial Interface for programming and data transfer
- SWKINT pin (pin17) to wake up mouse controller when sensor wakeup from sleep mode
- No fly on the air

**Key Specification**

<b>Power Supply</b>	1.73V ~ 1.87V (VDDD,VDDA, VDD) 2.5V ~ 2.9V (VDD)
<b>Optical Lens</b>	1:1
<b>System Clock</b>	27 MHz
<b>Speed</b>	20 inches/sec
<b>Resolution</b>	800/1000/1200/1600/2000 CPI
<b>Frame Rate</b>	6600 frames/sec
<b>Operating Current</b>	4mA @Mouse moving (Normal) 500uA @Mouse not moving (Sleep1) 100uA @Mouse not moving (Sleep2) 15uA @Power down mode
<b>Package</b>	Shrunk DIP20

**Ordering Information**

Order Number	I/O	Resolution
PAW3603DH-NF	CMOS output	800/1200/1600 CPI

**1. Pin Configuration**

**1.1 Pin Description**

Pin No.	Name	Type	Definition
1	VSS_LD	GND	LD ground
2	LD	OUT	LD control
3	OSCOUT	OUT	Resonator output
4	OSCIN	IN	Resonator input
5	VDDD	PWR	Chip digital power, 1.8V
6	VSSD	GND	Chip digital ground
7	VSSA	GND	Chip analog ground
8	VDD	PWR	Chip I/O power voltage, 1.73V ~ 1.87V( $V_{dd1}$ ) or 2.5V ~ 2.9V( $V_{dd2}$ )
9	VDDA	PWR	Chip analog power, 1.8V
10	VREF	BYPASS	Analog voltage reference
11	YA	OUT	YA quadrature output
12	YB	OUT	YB quadrature output
13	XA	OUT	XA quadrature output
14	XB	OUT	XB quadrature output
15	CPI	IN	CPI IO trap select pin Pull-high to VCC ( $V_{dd1}$ or $V_{dd2}$ ): 1200 CPI Pull-low to GND: 1600 CPI Floating: 800 CPI
16	NC	-	No connection
17	SWKINT	OUT	Sensor wakeup interrupt
18	SCLK	IN	Serial interface clock
19	SDIO	I/O	Serial interface bi-direction data
20	PD	IN	Power down pin, active high

**1.2 Pin Assignment**

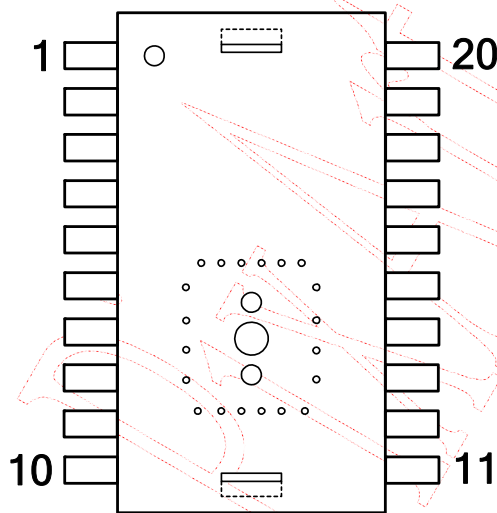

Figure 1. Top View Pinout

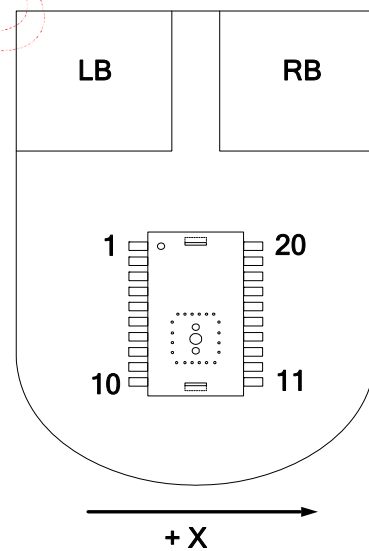

Figure 2. Top View of Mouse

2. Block Diagram and Operation

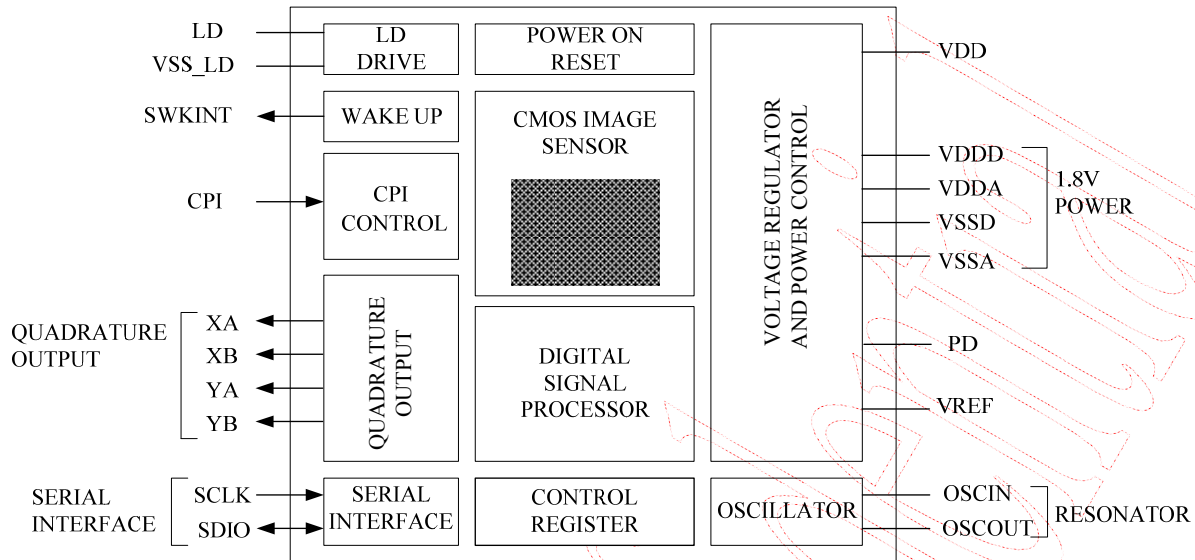

Figure 3. Block Diagram

In the traditional optical mouse, it uses LED as a light source. The light illuminates on the working surface and generates the bright and dark shadow that shows the micro-texture of the surface. The imaging sensor in the optical mouse chip captures sequential this micro-texture images of the working surface. Based on the captured images, the optical chip can determine the speed and direction when the optical mouse is moving. Thus, for the more rough surface, the more obvious shadow image will be generated and much easier to determine the movement and direction.

The PAW3603DH-NF is a CMOS laser mouse sensor with DSP integration chip that serves as a non-mechanical motion estimation engine for implementing a computer mouse. It is based on new laser speckle navigation technology. In the laser mouse, it uses laser diode (LD), specially uses VCSEL (Vertical Cavity Surface Emitting Laser) as light source, where laser is one kind of coherent light. When this light illuminates on the working surface, the surface will reflect and diffuse the incident light and generates speckle pattern. The imaging sensor in the laser mouse chip detects the speckle pattern that generated from the working surface and determines the movement and direction. Since the speckle pattern can be generated on the most of the surface if this surface is not perfect smooth or transparent, the laser-mouse can adapt on more surfaces as compared with traditional LED-based optical mouse. The sensor is in a 20-pin optical package. The output format is two-channel quadrature (X and Y direction), which emulates encoder phototransistors. The current X and Y information are also available in registers accessed via a serial port. The word "mouse sensor," instead of PAW3603DH-NF, is used in the document.

### 3. Registers and Operation

The mouse sensor can be programmed through registers, via the serial port, and DSP configuration and motion data can be read from these registers. All registers not listed are reserved, and should never be written by firmware.

#### 3.1 Registers

Address	Name	R/W	Default	Data Type
0x00	Product_ID1	R	0x30	Eight bits [11:4] number with the product identifier
0x01	Product_ID2	R	0x4X	Four bits [3:0] number with the product identifier Reserved [3:0] number is reserved for future
0x02	Motion_Status	R	-	Bit field
0x03	Delta_X	R	-	Eight bits 2's complement number
0x04	Delta_Y	R	-	Eight bits 2's complement number
0x05	Operation_Mode	R/W	-	Bit field
0x06	Configuration	R/W	-	Bit field
0x07	Image_Quality	R	-	Eight bits unsigned integer

#### 3.2 Register Descriptions

<b>0x00</b>	<b>Product_ID1</b>							
Bit	7	6	5	4	3	2	1	0
Field	PID[11:4]							
Usage	The value in this register can't change. It can be used to verify that the serial communications link is OK.							
<b>0x01</b>	<b>Product_ID2</b>							
Bit	7	6	5	4	3	2	1	0
Field	PID[3:0]				Reserved[3:0]			
Usage	The value in this register can't change. PID[3:0] can be used to verify that the serial communications link is OK. Reserved[3:0] is a value between 0x0 and 0xF, it can't be used to verify that the serial communications.							

0x02		Motion_Status						
Bit	7	6	5	4	3	2	1	0
Field	Motion	Reserved[1:0]		DYOVF	DXOVF	RES[2:0]		
Usage	<p>Register 0x02 allows the user to determine if motion has occurred since the last time it was read. If so, then the user should read registers 0x03 and 0x04 to get the accumulated motion. It also tells if the motion buffers have overflowed since the last reading. The current resolution is also shown.</p> <p>Reading this register freezes the <i>Delta_X</i> and <i>Delta_Y</i> register values. Read this register before reading the <i>Delta_X</i> and <i>Delta_Y</i> registers. If <i>Delta_X</i> and <i>Delta_Y</i> are not read before the motion register is read a second time, the data in <i>Delta_X</i> and <i>Delta_Y</i> will be lost.</p>							
Notes	<b>Field Name</b>	<b>Description</b>						
	Motion	Motion since last report or PD <b>0 = No motion (Default)</b> 1 = Motion occurred, data ready for reading in <i>Delta_X</i> and <i>Delta_Y</i> registers						
	Reserved[1:0]	Reserved for future use						
	DYOVF	Motion Delta Y overflow, $\Delta Y$ buffer has overflowed since last report <b>0 = No overflow (Default)</b> 1 = Overflow has occurred						
	DXOVF	Motion Delta X overflow, $\Delta X$ buffer has overflowed since last report <b>0 = No overflow (Default)</b> 1 = Overflow has occurred						
	RES[2:0]	Resolution in counts per inch 000 = 800 001 = 1000 010 = 1200 011 = 1600 100 = 2000						
0x03		Delta_X						
Bit	7	6	5	4	3	2	1	0
Field	X7	X6	X5	X4	X3	X2	X1	X0
Usage	X movement is counts since last report. Absolute value is determined by resolution. Reading clears the register. Report range $-128 \sim +127$ .							
0x04		Delta_Y						
Bit	7	6	5	4	3	2	1	0
Field	Y7	Y6	Y5	Y4	Y3	Y2	Y1	Y0
Usage	Y movement is counts since last report. Absolute value is determined by resolution. Reading clears the register. Report range $-128 \sim +127$ .							

0x05	Operation_Mode																									
Bit	7	6	5	4	3	2	1	0																		
Field	LEDsht_enh	XY_enh	Reserved[1]	Slp_enh	Slp2au	Reserved[0]	Slp1mu	Wakeup																		
Usage	<p>Register 0x05 allows the user to change the operation of the sensor. Shown below are the bits, their default values, and optional values.</p> <p>Operation_Mode[4:0]                      “0x0xx” = Disable sleep mode                      “100xx” = Enable sleep mode<sup>1</sup>                      “110xx” = Enable sleep mode<sup>2</sup>                      “1x010” = Force enter sleep1<sup>3</sup>                      “1x001” = Force wakeup from sleep mode<sup>3</sup></p> <p>Notes:                      1. Enable sleep mode, but disable automatic entering sleep2 mode, that is, only 2 modes will be used, normal mode and sleep1 mode. After 78 ms not moving during normal mode, the mouse sensor will enter sleep1 mode, and keep on sleep1 mode until moving is detected or wakeup is asserted.                      2. Enable sleep mode full function, that is 3 modes will be used, normal mode, sleep1 mode and sleep2 mode. After 78 ms not moving during normal mode, the mouse sensor will enter sleep1 mode, and keep on sleep1 mode until moving is detected or wakeup is asserted.                      And after 60 sec ±40% not moving during sleep1 mode, the mouse sensor will enter sleep2 mode, and keep on sleep2 mode until detect moving or force wakeup to normal mode.</p> <table border="1"> <thead> <tr> <th>Mode</th> <th>Sampling rate @6600 frame/sec</th> <th>Active duty cycle @6600 frame/sec</th> </tr> </thead> <tbody> <tr> <td>Sleep1</td> <td>45/sec</td> <td>22.7%</td> </tr> <tr> <td>Sleep2</td> <td>3/sec</td> <td>1.6%</td> </tr> </tbody> </table> <p>Note that these values have ±40% range above list. (ex: 45/sec -&gt; 27/sec ~ 63/sec)</p> 3. Only one of slp1mu_enh and wakeup bit can be set to 1 at the same time, others have to be set to 0. After a period of time, the bit, which was set to 1, will be reset to 0 by internal signal.								Mode	Sampling rate @6600 frame/sec	Active duty cycle @6600 frame/sec	Sleep1	45/sec	22.7%	Sleep2	3/sec	1.6%									
Mode	Sampling rate @6600 frame/sec	Active duty cycle @6600 frame/sec																								
Sleep1	45/sec	22.7%																								
Sleep2	3/sec	1.6%																								
Notes	<table border="1"> <thead> <tr> <th>Field Name</th> <th>Description</th> </tr> </thead> <tbody> <tr> <td>LEDsht_enh</td> <td>LED shutter enable/disable 0 = Disable <b>1 = Enable (Default)</b></td> </tr> <tr> <td>XY_enh</td> <td>XY quadrature output enable/disable 0 = Disable <b>1 = Enable (Default)</b></td> </tr> <tr> <td>Reserved[1]</td> <td>Reserved for future use. Must be written to one</td> </tr> <tr> <td>Slp_enh</td> <td>Sleep mode enable/disable 0 = Disable <b>1 = Enable (Default)</b></td> </tr> <tr> <td>Slp2au</td> <td>Automatic enter sleep2 mode enable/disable 0 = Disable <b>1 = Enable (Default)</b></td> </tr> <tr> <td>Reserved[0]</td> <td>Reserved for future use. Must be written to zero.</td> </tr> <tr> <td>Slp1mu</td> <td>Manual enter sleep1 mode, set “1” will enter sleep1 and this bit will be reset to “0”</td> </tr> <tr> <td>Wakeup</td> <td>Manual wake up from sleep mode, set “1” will enter wakeup and this bit will be reset to “0”</td> </tr> </tbody> </table>								Field Name	Description	LEDsht_enh	LED shutter enable/disable 0 = Disable <b>1 = Enable (Default)</b>	XY_enh	XY quadrature output enable/disable 0 = Disable <b>1 = Enable (Default)</b>	Reserved[1]	Reserved for future use. Must be written to one	Slp_enh	Sleep mode enable/disable 0 = Disable <b>1 = Enable (Default)</b>	Slp2au	Automatic enter sleep2 mode enable/disable 0 = Disable <b>1 = Enable (Default)</b>	Reserved[0]	Reserved for future use. Must be written to zero.	Slp1mu	Manual enter sleep1 mode, set “1” will enter sleep1 and this bit will be reset to “0”	Wakeup	Manual wake up from sleep mode, set “1” will enter wakeup and this bit will be reset to “0”
Field Name	Description																									
LEDsht_enh	LED shutter enable/disable 0 = Disable <b>1 = Enable (Default)</b>																									
XY_enh	XY quadrature output enable/disable 0 = Disable <b>1 = Enable (Default)</b>																									
Reserved[1]	Reserved for future use. Must be written to one																									
Slp_enh	Sleep mode enable/disable 0 = Disable <b>1 = Enable (Default)</b>																									
Slp2au	Automatic enter sleep2 mode enable/disable 0 = Disable <b>1 = Enable (Default)</b>																									
Reserved[0]	Reserved for future use. Must be written to zero.																									
Slp1mu	Manual enter sleep1 mode, set “1” will enter sleep1 and this bit will be reset to “0”																									
Wakeup	Manual wake up from sleep mode, set “1” will enter wakeup and this bit will be reset to “0”																									

0x06	Configuration																																																												
Bit	7	6	5	4	3	2	1	0																																																					
Field	Reset	Reserved[2]	Cpimd	Reserved[1]	PD_enh	Reserved[0]	CPI [1:0]																																																						
Usage	The <b>Configuration</b> register allows the user to change the configuration of the sensor. Shown below are the bits, their default values, and optional values.																																																												
Notes	<b>Field Name</b>	<b>Description</b>																																																											
	Reset	Full chip reset <b>0 = Normal operation mode (Default)</b> 1 = Full chip reset																																																											
	Reserved[2]	Reserved for future use. Must be written to zero.																																																											
	Cpimd	CPI mode select																																																											
	Reserved[1]	Reserved for future use. Must be written to zero.																																																											
	PD_enh	Power down mode <b>0 = Normal operation (Default)</b> 1 = Power down mode																																																											
	Reserved[0]	Reserved for future use. Must be written to zero.																																																											
	CPI[1:0]	Output resolution setting, setting with CPI mode select bit (Cpimd)																																																											
		<table border="1"> <thead> <tr> <th rowspan="2">PIN15</th> <th colspan="2">Register</th> <th rowspan="2">CPI</th> </tr> <tr> <th>Cpimd</th> <th>CPI[1:0]</th> </tr> </thead> <tbody> <tr> <td>Low</td> <td>0</td> <td>0</td> <td>1600</td> </tr> <tr> <td>Low</td> <td>0</td> <td>1,2</td> <td>800</td> </tr> <tr> <td>Low</td> <td>0</td> <td>3</td> <td>1200</td> </tr> <tr> <td>Low</td> <td>1</td> <td>0</td> <td>2000</td> </tr> <tr> <td>Low</td> <td>1</td> <td>1,2</td> <td>1000</td> </tr> <tr> <td>Low</td> <td>1</td> <td>3</td> <td>1600</td> </tr> <tr> <td>High</td> <td>0</td> <td>0</td> <td>1200</td> </tr> <tr> <td>Low</td> <td>0</td> <td>0</td> <td>1600</td> </tr> <tr> <td>Floating</td> <td>0</td> <td>0</td> <td>800</td> </tr> <tr> <td>High</td> <td>1</td> <td>0</td> <td>1600</td> </tr> <tr> <td>Low</td> <td>1</td> <td>0</td> <td>2000</td> </tr> <tr> <td>Floating</td> <td>1</td> <td>0</td> <td>1000</td> </tr> </tbody> </table>		PIN15	Register		CPI	Cpimd	CPI[1:0]	Low	0	0	1600	Low	0	1,2	800	Low	0	3	1200	Low	1	0	2000	Low	1	1,2	1000	Low	1	3	1600	High	0	0	1200	Low	0	0	1600	Floating	0	0	800	High	1	0	1600	Low	1	0	2000	Floating	1	0	1000				
PIN15	Register		CPI																																																										
	Cpimd	CPI[1:0]																																																											
Low	0	0	1600																																																										
Low	0	1,2	800																																																										
Low	0	3	1200																																																										
Low	1	0	2000																																																										
Low	1	1,2	1000																																																										
Low	1	3	1600																																																										
High	0	0	1200																																																										
Low	0	0	1600																																																										
Floating	0	0	800																																																										
High	1	0	1600																																																										
Low	1	0	2000																																																										
Floating	1	0	1000																																																										
Note that the PIN15 MUST be Low if customers want to change every cpi scale via Configuration register.																																																													

0x07	Image_Quality							
Bit	7	6	5	4	3	2	1	0
Field	Imgqa[7:0]							
Usage	Image Quality is a quality level of the sensor in the current frame. Report range 0 ~ 255. The minimum level for normally working is 15.							
Notes	<b>Field Name</b>	<b>Description</b>						
	Imgqa[7:0]	Image quality report range: 0(worst) ~ 255(best).						

PixArt Confidential



## 4. Specifications

### 4.1 Absolute Maximum Ratings

Stresses above those listed under "Absolute Maximum Rating" may cause permanent damage to the device. These are stress ratings only. Functional operation of this device at these or any other conditions above those indicated in the operational sections of this specification is not implied and exposure to absolute maximum rating conditions for extended periods may affect device reliability.

Symbol	Parameter	Min	Max	Unit	Notes
T <sub>STG</sub>	Storage Temperature	-40	85	°C	
T <sub>A</sub>	Operating Temperature	-15	55	°C	
V <sub>DC</sub>	DC Supply Voltage	-0.5	V <sub>dd1</sub> + 0.2	V	
		-0.5	V <sub>dd2</sub> + 0.3	V	
V <sub>IN</sub>	DC Input Voltage	-0.5	V <sub>DC</sub>	V	All I/O pin
	Lead Solder Temp		260	°C	For 10 seconds, 1.6mm below seating plane.
ESD			2	kV	All pins, human body model MIL 883 Method 3015

### 4.2 Recommend Operating Condition

Symbol	Parameter	Min.	Typ.	Max.	Unit	Notes
T <sub>A</sub>	Operating Temperature	0		40	°C	
V <sub>dd1</sub>	Power Supply Voltage	1.73	1.8	1.87	V	VDDD, VDDA, VDD short
V <sub>dd2</sub>		2.5	2.7	2.9		VDD
V <sub>N</sub>	Supply Noise			100	mV	Peak to peak within 0 - 80 MHz
Z	Distance from Lens Reference Plane to Surface	2.3	2.4	2.5	mm	
R	Resolution	800	1600	2000	CPI	
C <sub>L</sub>	Load Capacitance of Resonator		15		pF	
SCLK	Serial Port Clock Frequency			10	MHz	
F <sub>CLK</sub>	Clock Frequency		27		MHz	
FR	Frame Rate		6600		frames/s	
S	Speed	0		20	inches/s	

### 4.3 AC Operating Condition

Electrical Characteristics over recommended operating conditions. Typical values at 25 °C, V<sub>DD</sub> = 1.8 V, pin 5, 8, 9 short, F<sub>CLK</sub> = 27 MHz

Symbol	Parameter	Min.	Typ.	Max.	Unit	Notes
t <sub>PDR</sub>	PD Pulse Register			304	us	One frame time maximum after setting <i>PD_enh</i> bit in the <i>Configuration</i> register @6600frame/sec (refer to Figure 15).
t <sub>PD</sub>	Power Down		500		us	From PD↑ (refer to Figure 13)
t <sub>PDW</sub>	PD Pulse Width	700			us	Pulse width to reset the serial interface (refer to Figure 13).
t <sub>PUPD</sub>	Power Up from PD↓	3		14	ms	From PD↓ to valid quad signals. After t <sub>PUPD</sub> , all registers contain valid data from first image after PD↓. Note that an additional 90 frames for Auto-Exposure (AE) stabilization may be required if mouse movement occurred while PD was high (refer to Figure 13).
t <sub>PU</sub>	Power Up from V <sub>DD</sub> ↑	3		14	ms	From V <sub>DD</sub> ↑ to valid quad signals. 500usec + 90 frames.
t <sub>HOLD</sub>	SDIO Read Hold Time		3		us	Minimum hold time for valid data (refer to Figure 11).
t <sub>RESYNC</sub>	Serial Interface RESYNC.	1			us	@6600 frame/sec (refer to Figure 12)
t <sub>SIWTT</sub>	Serial Interface Watchdog Timer Timeout	1.7 22 320			ms	@6600 frame/sec (refer to Figure 12) 1.7ms (±40%) for normal mode, 22ms (±40%) for sleep1 mode, 320ms (±40%) for sleep2 mode.
t <sub>SWKINT</sub>	Sensor Wakeup Interrupt Time		75		us	
t <sub>r</sub> , t <sub>f</sub>	Rise and Fall Times: SDIO		30, 25		ns	C <sub>L</sub> = 30 pF
t <sub>r</sub> , t <sub>f</sub>	Rise and Fall Times: XA, XB, YA, YB		20, 20		ns	C <sub>L</sub> = 30 pF
t <sub>r</sub> , t <sub>f</sub>	Rise and Fall Times: ILED		10, 10		ns	LED bin grade: R; R1 = 100 ohm

**4.4 DC Electrical Characteristics**

Electrical Characteristics over recommended operating conditions. Typical values at 25 °C, V<sub>DD</sub> = 1.8 V, pin 5, 8, 9 short, F<sub>CLK</sub> = 27MHz

Symbol	Parameter	Min.	Typ.	Max.	Unit	
<b>Type: Power</b>						
I <sub>DD</sub>	Supply Current Mouse Moving (Normal)		4		mA	
I <sub>DD</sub>	Supply Current Mouse Not Moving (Sleep1)		500		uA	
I <sub>DD</sub>	Supply Current Mouse Not Moving (Sleep2)		100		uA	PD, SCLK, SDIO = high
I <sub>DDPD</sub>	Supply Current (Power Down)		15		uA	
<b>Type: SCLK, SDIO, PD</b>						
V <sub>IH</sub>	Input Voltage HIGH	1.25				
V <sub>IL</sub>	Input Voltage LOW			0.5	V	
<b>Type: XA, XB, YA, YB</b>						
V <sub>OH</sub>	Output Voltage HIGH	1.2			V	@I <sub>OH</sub> = 2mA
V <sub>OL</sub>	Output Voltage LOW			0.2	V	@I <sub>OL</sub> = 2mA



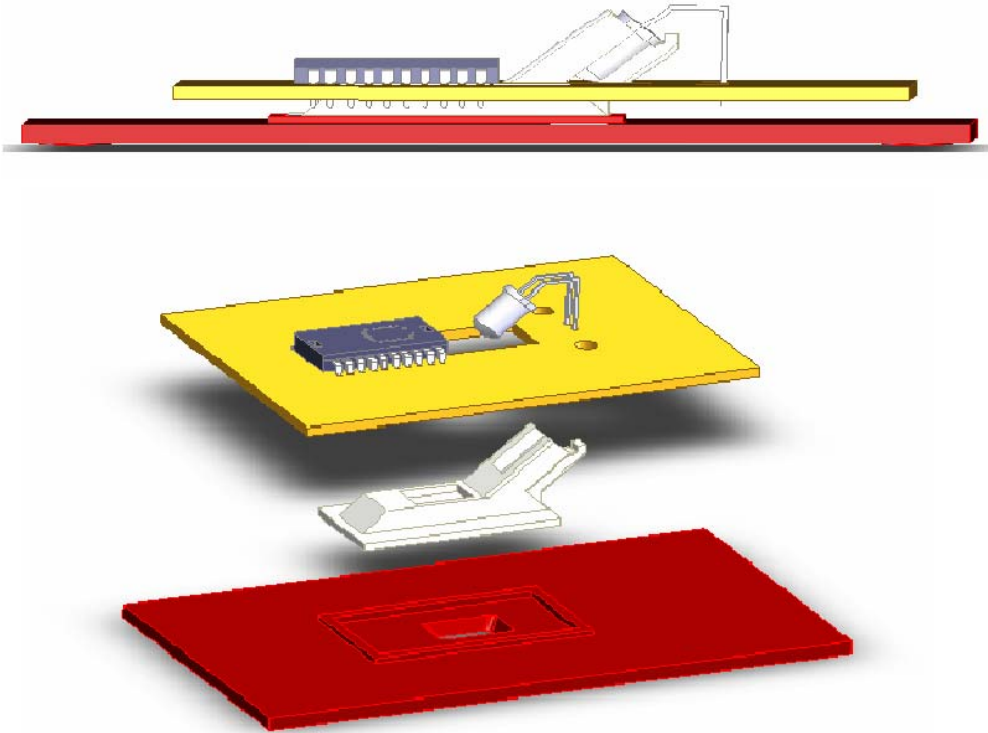

Figure 5. 3D Assembly

PIXART.COM

### 6. Quadrature Mode

The quadrature state of the mouse sensor tells the mouse controller which direction the mouse is moving in. The output format is two channels quadrature (X and Y direction), which emulates encoder phototransistors. The DSP generates the  $\Delta x$  and  $\Delta y$  relative displacement values that are converted into two channel quadrature signals. The following diagrams show the timing for positive X motion, to the right or positive Y motion, up.

#### 6.1 Quadrature Output Timing

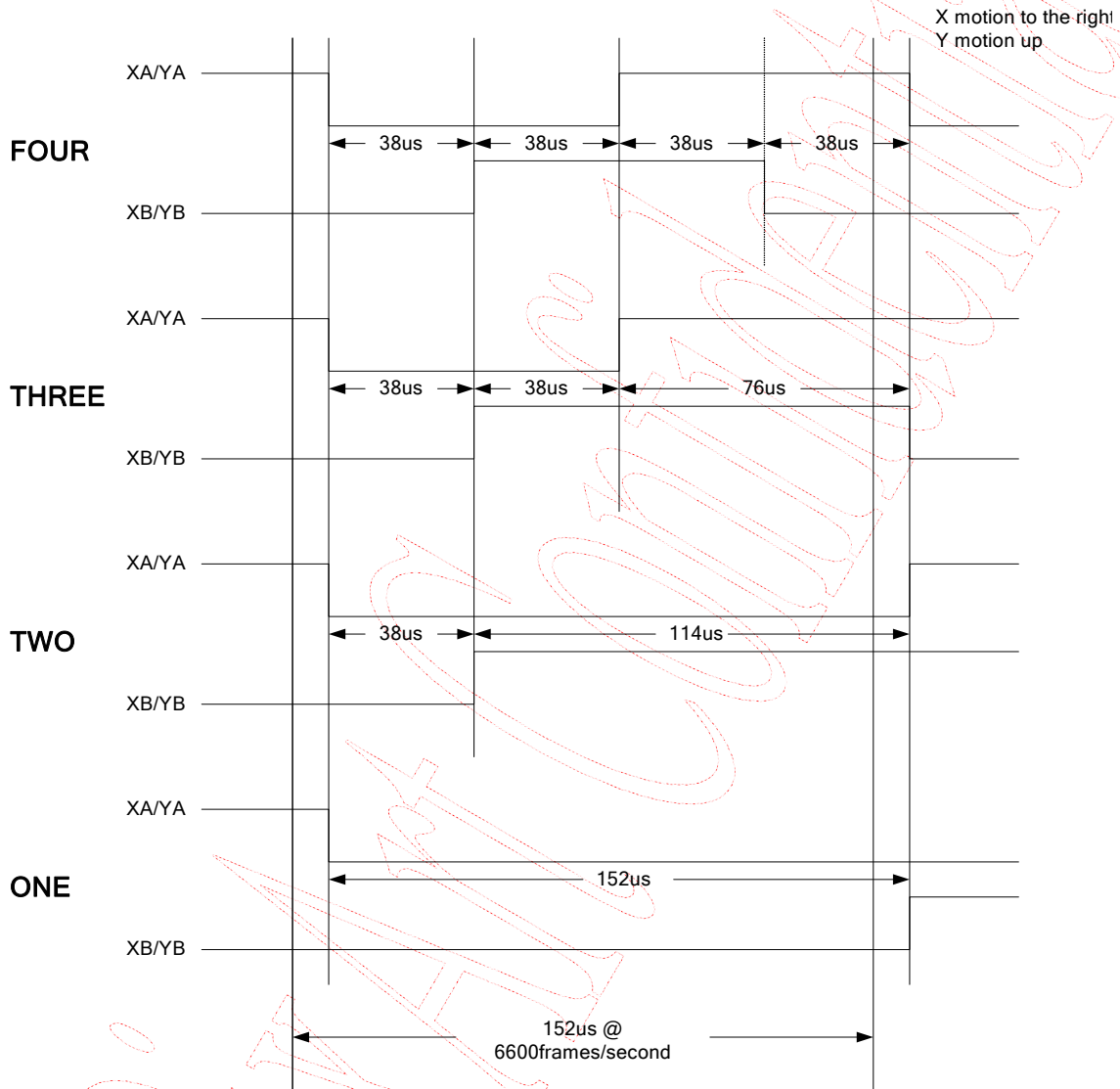

Figure 6. Quadrature Output Timing

### 6.2 Quadrature Output State Machine

The following state machine shows the states of the quadrature output pins. The three things to note are that state 0 is entered after a power on reset. While the PD pin is asserted, the state machine is halted. Once PD is deasserted, the state machine picks up from where it left off. During times of mouse no movement will entry power saving mode, until mouse was moved.

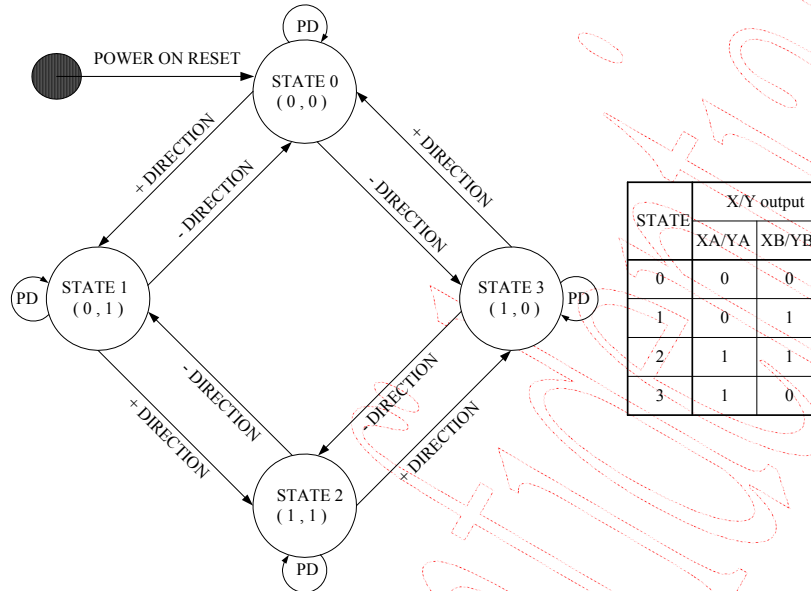

Figure 7. State Machine

### 6.3 Quadrature Output Waveform

The following diagrams show the waveform of the two channel quadrature outputs. If the X, Y is motionless, the (XA, XB), (YA, YB) will keep in final state. Each state change (ex. STATE2 → STATE3) is one count.

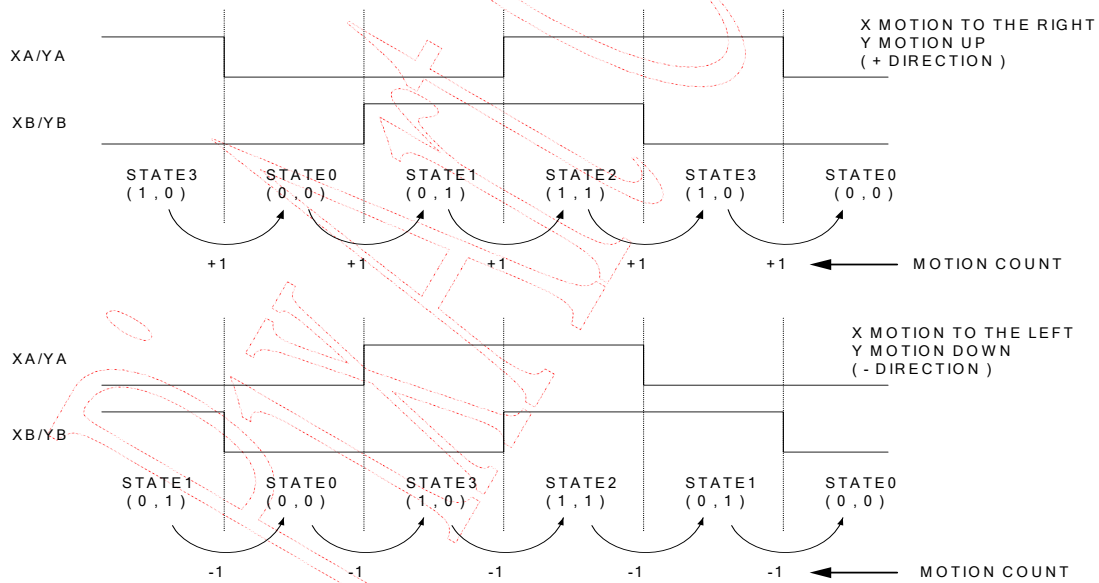

Figure 8. Quadrature Output Waveform

### 7. Serial Interface

The synchronous serial port is used to set and read parameters in the mouse sensor, and can be used to read out the motion information instead of the quadrature data pins.

**SCLK:** The serial clock line. It is always generated by the mouse controller.

**SDIO:** The serial data line is used to write and read data.

**PD:** A third line is sometimes involved. PD line (Power Down pin) is usually used to place the mouse sensor in a low power mode to meet USB suspend specification. PD line can also be used to force re-synchronization between the mouse controller and the mouse sensor in case of an error.

#### 7.1 Transmission Protocol

The transmission protocol is a two-wire link, half duplex protocol between the mouse controller and the mouse sensor. All data changes on SDIO are initiated by the falling edge on SCLK. The mouse controller always initiates communication; the mouse sensor never initiates data transfers.

The transmission protocol consists of the two operation modes:

- Write Operation.
- Read Operation.

Both of the two operation modes consist of two bytes. The first byte contains the address (seven bits) and has a bit 7 as its MSB to indicate data direction. The second byte contains the data.

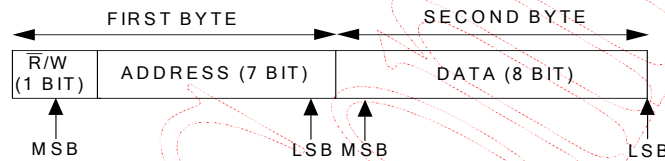

Figure 9. Transmission Protocol

#### 7.1.1 Write Operation

A write operation, which means that data is going from the mouse controller to the mouse sensor, is always initiated by the mouse controller and consists of two bytes. The first byte contains the address (seven bits) and has a “1” as its MSB to indicate data direction. The second byte contains the data. The transfer is synchronized by SCLK. The mouse controller changes SDIO on falling edges of SCLK. The mouse sensor reads SDIO on rising edges of SCLK.

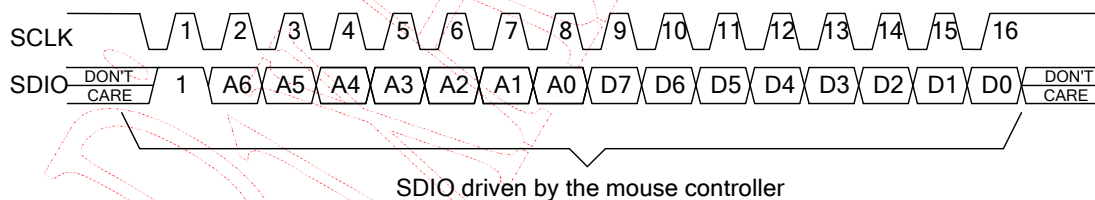
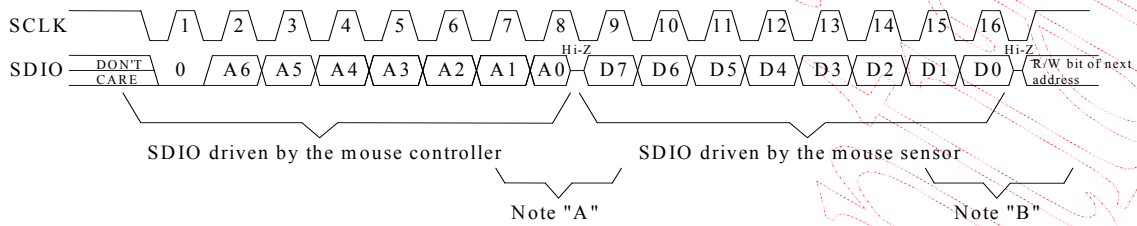

Figure 10. Write Operation



### 7.1.2 Read Operation

A read operation, which means that data is going from the mouse sensor to the mouse controller, is always initiated by the mouse controller and consists of two bytes. The first byte contains the address, is written by the mouse controller, and has a “0” as its MSB to indicate data direction. The second byte contains the data and is driven by the mouse sensor. The transfer is synchronized by SCLK. SDIO is changed on falling edges of SCLK and read on every rising edge of SCLK. The mouse controller must go to a high Z state after the last address data bit. The mouse sensor will go to the high Z state after the last data bit.



- Note "A" 1. The mouse controller sends address to the mouse sensor.  
 2. The mouse controller releases and set SDIO to Hi-Z after the last address bit.

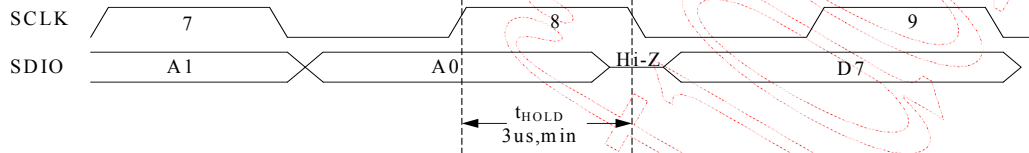

- Note "B" 1. The mouse sensor sends data to the mouse controller.  
 2. The mouse sensor releases and set SDIO to Hi-Z after the last data bit.

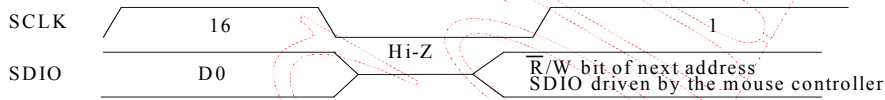

Figure 11. Read Operation

### 7.2 Re-Synchronous Serial Interface

If the mouse controller and the mouse sensor get out of synchronization, then the data either written or read from the registers will be incorrect. In such a case, an easy way to solve this condition is to toggle the SCLK line from high to low to high and wait at least  $t_{SIWTT}$  to reach re-synchronous the parts after an incorrect read. This method is called by “watchdog timer timeout”. The mouse sensor will reset the serial port but will not reset the registers and be prepared for the beginning of a new transmission.

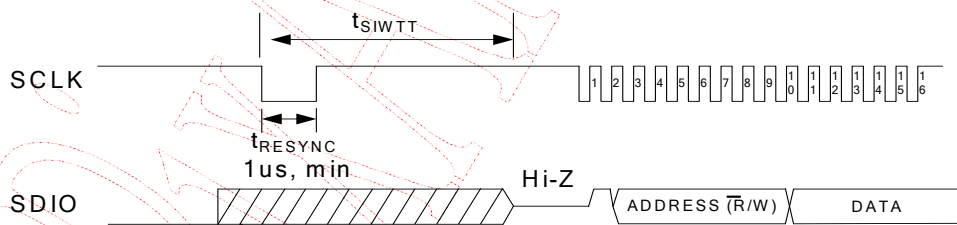

Figure 12. Re-synchronous Serial Interface Using Watchdog Timer Timeout

Note that this function is disabled when the mouse sensor is in the power down mode. If the user uses this function during the power down mode, it will get out of synchronization. The mouse sensor and the mouse controller also might get out of synchronization due to following conditions.

- Power On Problem - The problem occurs if the mouse sensor powers up before the mouse controller sets the SCLK and SDIO lines to be output. The mouse sensor and the mouse controller might get out of synchronization due to power on problem. An easy way to solve this is to use “watchdog timer timeout”.
- ESD Events - The mouse sensor and the mouse controller might get out of synchronization due to ESD events. An easy way to solve this is to use “watchdog timer timeout”

### 7.3 Collision Detection on SDIO

The only time that the mouse sensor drives the SDIO line is during a READ operation. To avoid data collisions, the mouse controller should release SDIO before the falling edge of SCLK after the last address bit. The mouse sensor begins to drive SDIO after the next falling edge of SCLK. The mouse sensor releases SDIO of the rising SCLK edge after the last data bit. The mouse controller can begin driving SDIO any time after that. In order to maintain low power consumption in normal operation or when the PD pin is pulled high, the mouse controller should not leave SDIO floating until the next transmission (although that will not cause any communication difficulties).

### 7.4 Power Down Mode

There are two different ways to entry power down mode, using the PD line (see Section 7.4.1) or register setting (see Section 7.4.2).

#### 7.4.1 PD Line Power Down Mode

To place the mouse sensor in a low power mode to meet USB suspend specification raises the PD line at least  $t_{PDW}$ . Then PD line can stay high, with the mouse sensor in the shutdown state, or the PD pin can be lowered, returning the mouse sensor to normal operation.

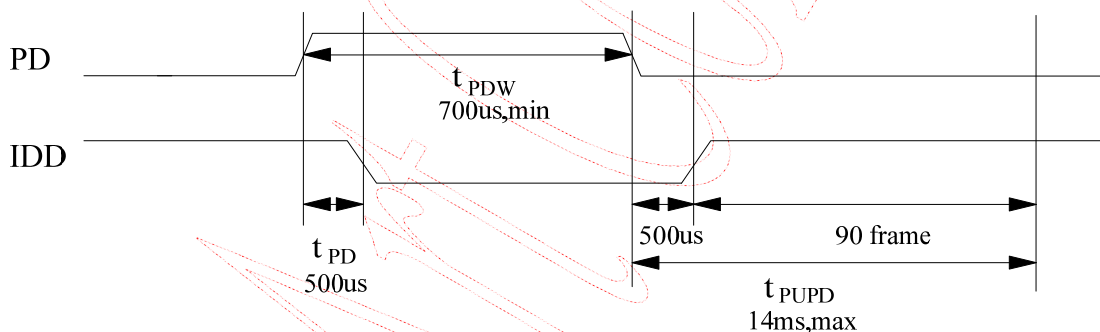

Figure 13. Power Down Minimum Pulse Width

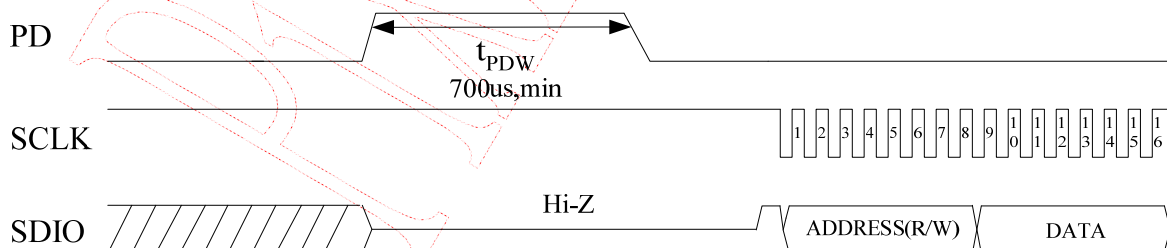

Figure 14. PD Line Power Down Mode

### 7.4.2 Register Power Down Mode

The mouse sensor can be placed in a power down mode by setting *PD\_enh* bit in the *configuration* register via a serial port write operation. After setting the *configuration* register, wait at least 1 frame times. To get the chip out of the power down mode, clear *PD\_enh* bit in the *configuration* register via a serial port write operation. In the power down mode, the serial interface watchdog timer is not available (see Section 7.2). But, the serial interface still can read/write normally. For an accurate report after leave the power down mode, wait about 3ms before the mouse controller is able to issue any write/read operation to the mouse sensor.

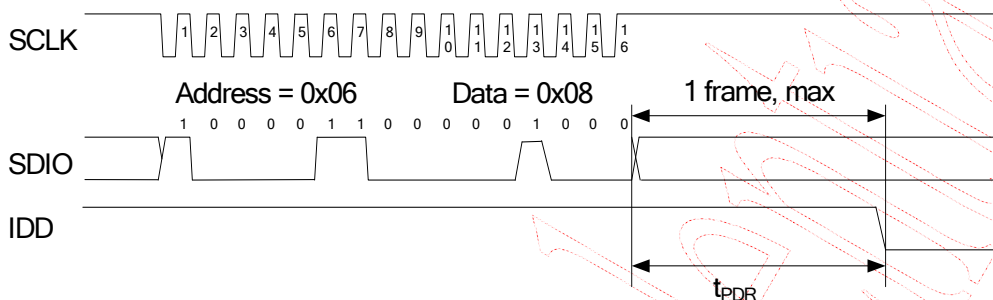

Figure 15. Power-down Configuration Register Writing Operation

### 7.5 Error Detection

1. The mouse controller can verify success of write operations by issuing a read command to the same address and comparing written data to read data.
2. The mouse controller can verify the synchronization of the serial port by periodically reading the product ID register.

### 8. SWKINT Timing

When the mouse sensor is in sleep mode and the mouse controller is also in sleep mode, if the mouse sensor finds motion occurred at this moment, the mouse sensor wake mouse controller up promptly via SWKINT.

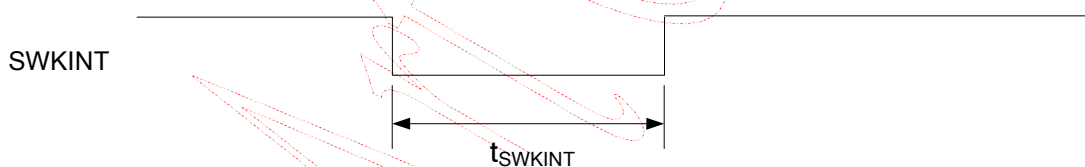
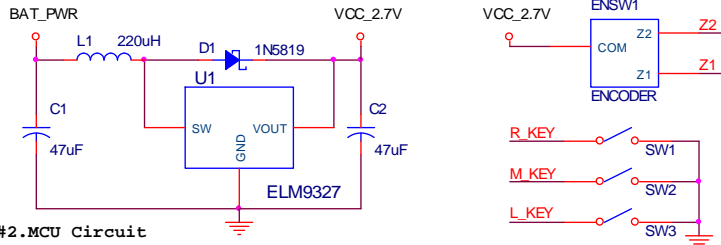

Figure 16. SWKINT Timing

## 9. Referencing Application Circuit

### 9.1 2.7V Application Circuit

#### #1. Battery Power Circuit



#### #2. MCU Circuit

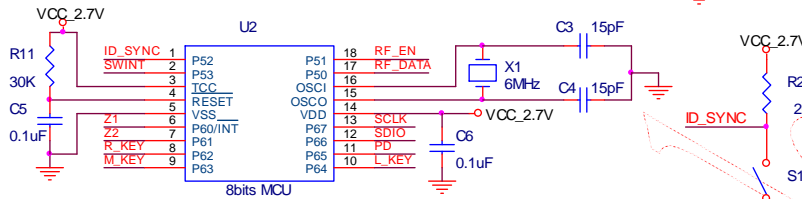

#### #3. RF TX Circuit

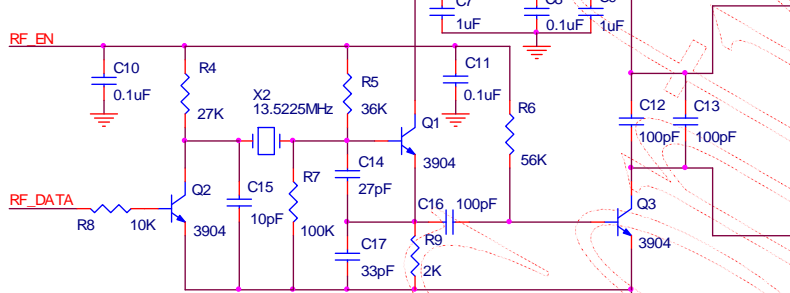

#### #4. Sensor Circuit

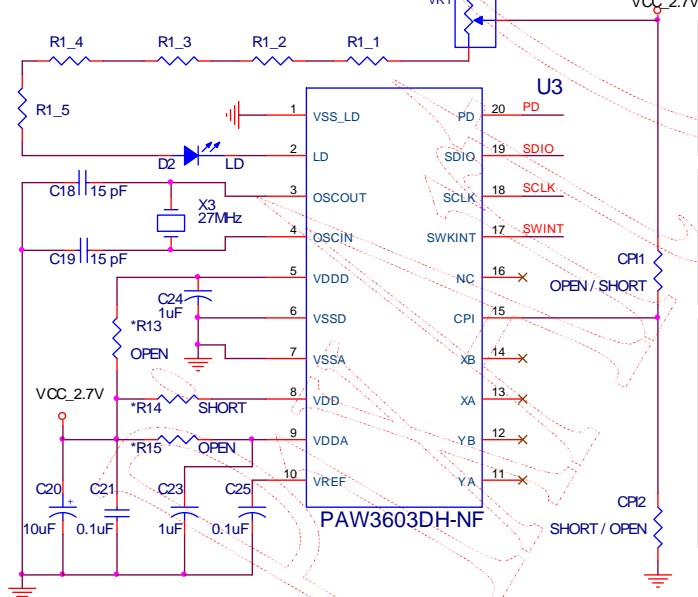

PAW3603 CPI SETTING		
CPI1	CPI2	Resolution
OPEN	0R	1600 CPI
0R	OPEN	1200 CPI
OPEN	OPEN	800 CPI

**PAW3603 USED 2.7V POWER**  
 \*R14 => 0R  
 \*R13, \*R15 => OPEN

**PAW3603 USED 1.8V POWER**  
 \*R13, \*R14, \*R15 => 0R

- Note:**
- U1 are suggested to use +/- 2.5% high accuracy DC/DC converter
  - R1\_1, R1\_2, R1\_3, R1\_4, R1\_5 are suggested to use 1% precise resistor
  - VR1 is C3305 100ohm VR for JAY WEI INDUS. CORP

Figure 17. Application Circuit for 2.7V

9.2 1.8V Application Circuit

#1. Battery Power Circuit

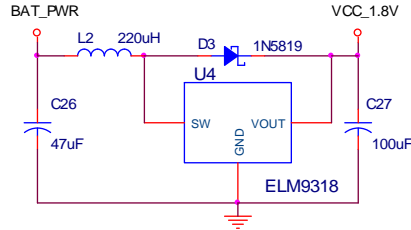

#2. MCU Circuit

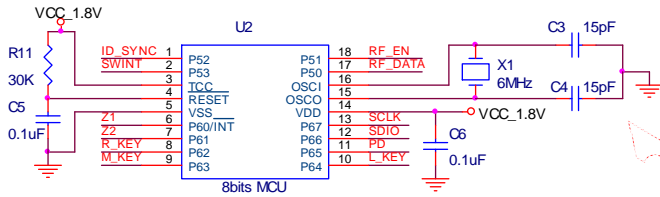

#3. RF TX Circuit

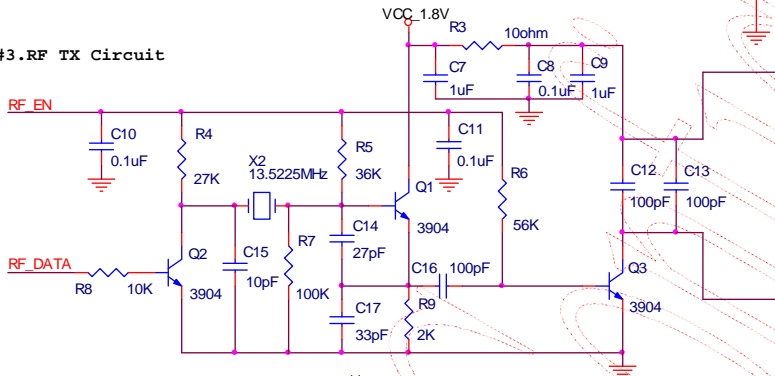

#4. Sensor Circuit

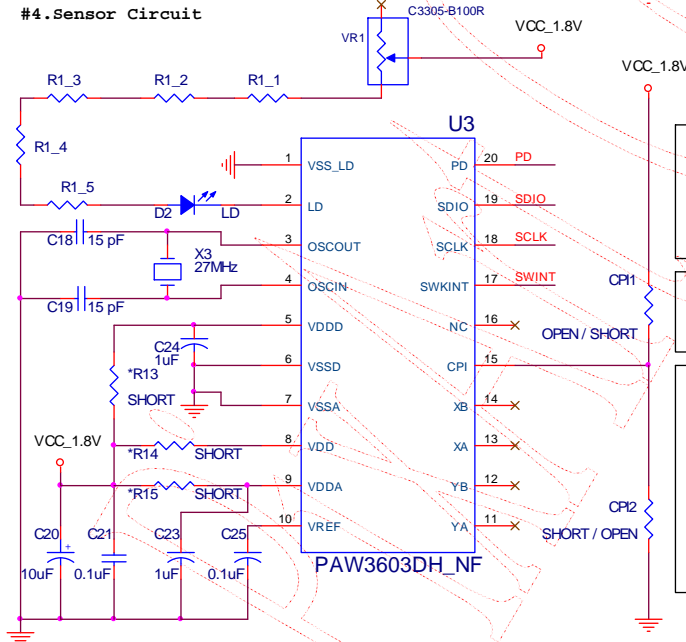

PAW3603 CPI SETTING		
CPI1	CPI2	Resolution
0R	0R	1600 CPI
0R	OPEN	1200 CPI
OPEN	OPEN	800 CPI

**PAW3603 USED 1.8V POWER**  
 \*R13, \*R14, \*R15 => 0R

**Note:**

- U4 are suggested to use +/- 2.5% high accuracy DC/DC converter
- R1\_1, R1\_2, R1\_3, R1\_4, R1\_5 are suggested to use 1% precise resistor
- VR1 is C3305 100ohm VR for JAY WEI INDUS. CORP

Figure 18. Application Circuit for 1.8V

9.3 Reference Application for RF Receiver

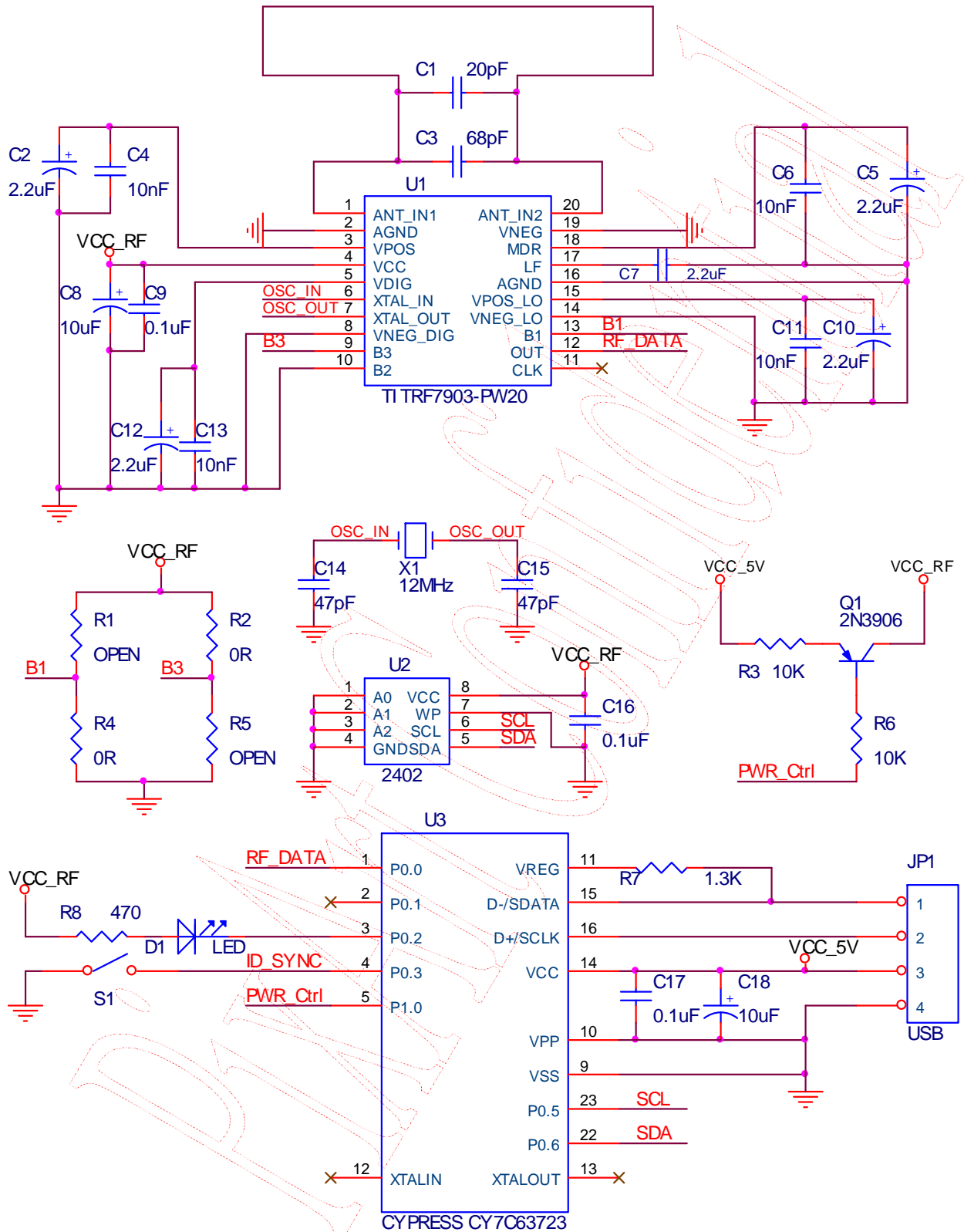

Figure 19. Application Circuit for RF Receive

#### 9.4 PCB Layout Consideration

1. Caps for pins 5, 8, 9, 10 must have trace lengths less than **5mm**.
2. The trace lengths of OSCOUT, OSCIN must less than **6mm**.
3. Avoid the eye safety issue, please placement the R1\_1 ~ R1\_5 and VR1 in a straight line and avoid any resistor to short each other or short to VCC.
4. Avoid the eye safety issue, please guard the trace from LD's cathode to mouse sensor's PIN2 (LD) and avoid short to ground.

PixArt Confidential

10. Package Information

10.1 Package Outline Drawing

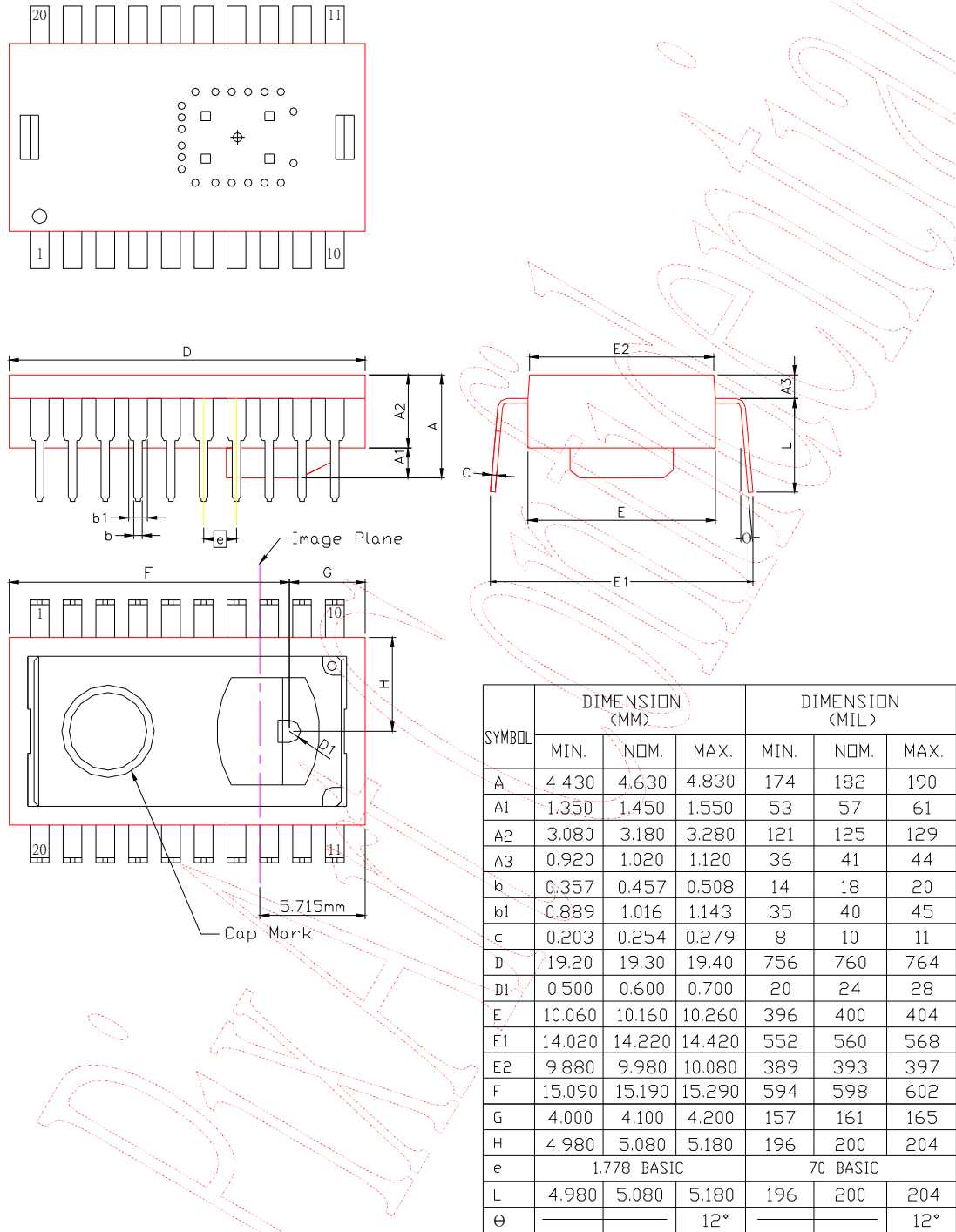
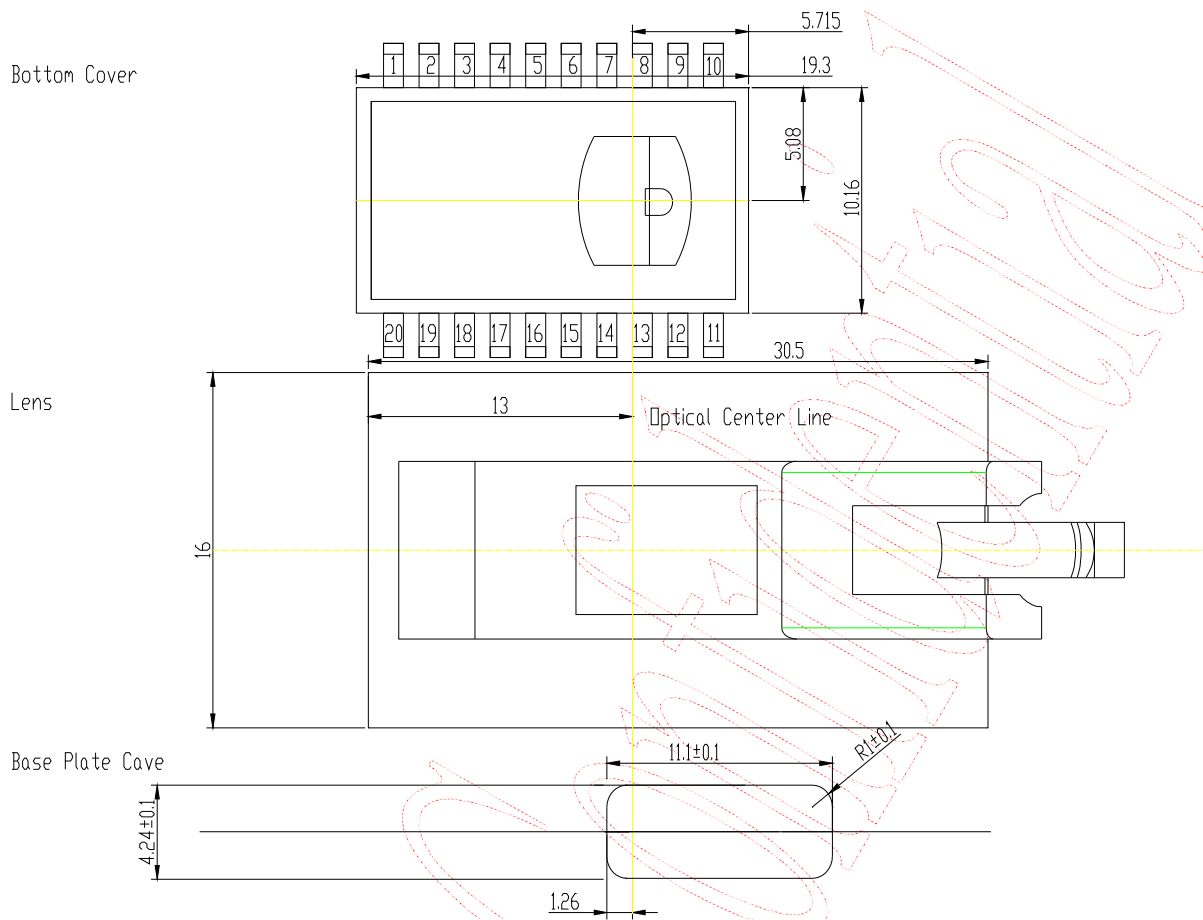

Figure 20. Package Outline Drawing



### 10.2 Base Plate Molding Dimension



All Dimensions : mm

Figure 21. Base Plate Molding Dimension

### 10.3 Recommended PCB Mechanical Cutouts and Spacing

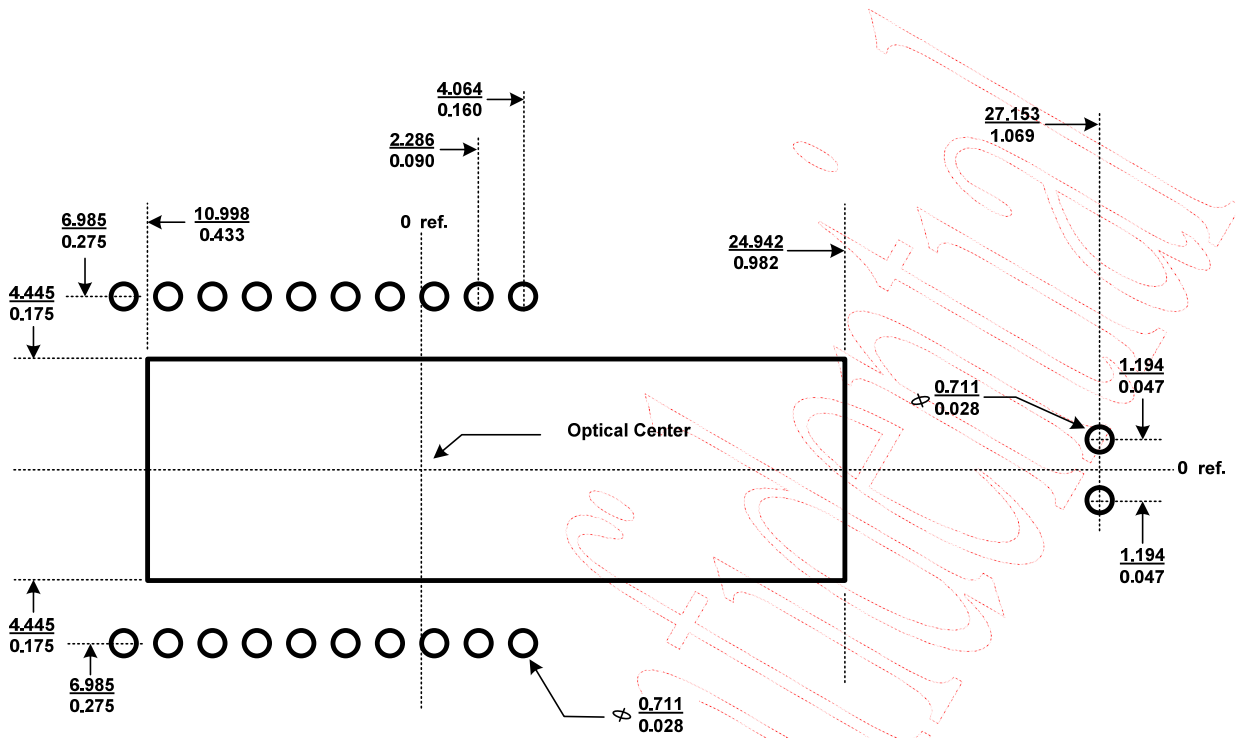

All Dimensions : mm / inch

Figure 22. Recommended PCB Mechanical Cutouts and Spacing

### 11. Update History

Version	Update	Date
V1.0	Creation, Preliminary 1 <sup>st</sup> version	08/28/2007

# Vertical Cavity Surface Emitting Laser (VCSEL)

## Components Specification

### Distribution

Internal Only

External All

External Restricted

If restricted, specify restricted to whom:

\_\_\_\_\_

**Document No.:** PNDR-00022

**Revision:** Rev 2.0

**Date:** 2007/08/27

## Revision History

Revision	Author	Date	Description
1.0	Chadwick	2007/01/18	Initial version
1.5	Chadwick	2007/05/04	Revise resistor table for higher CW radiant power 300uW ~650uW on Mouse operation ; Delete P32/P64 Grades
2.0	Chadwick	2007/08/27	Revise resistor table for higher CW radiant power 300uW ~650uW on Mouse operation ; Delete LD P50~P60 Grades for VDD=1.8V

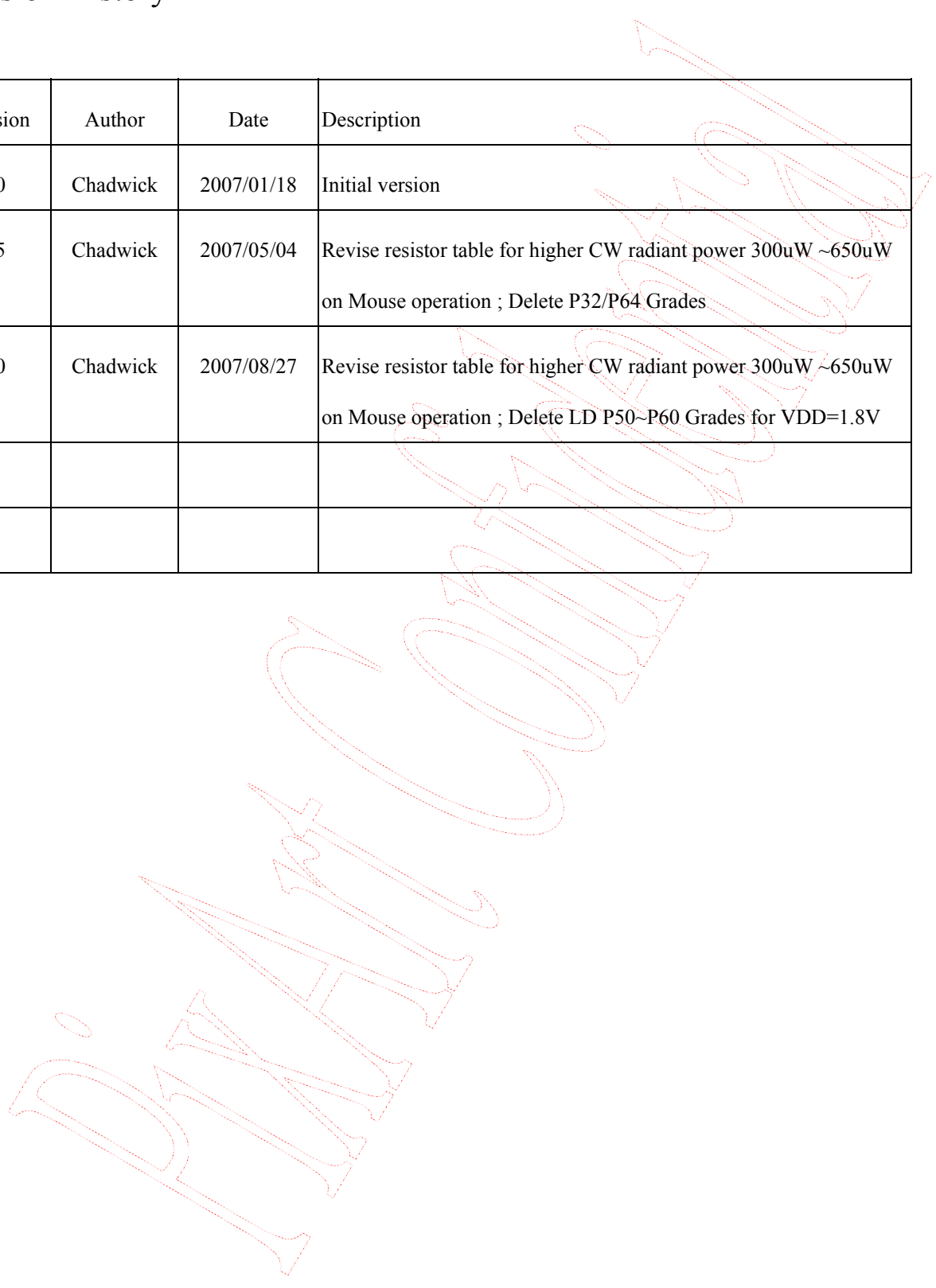

**PNDR-00022****850nm Epoxy molded VCSEL for Laser Mouse****FEATURES**

- Epoxy Molded with round emission surface.
- Small divergence angle.

**ELECTRO-OPTICAL CHARACTERISTICS:**

PARAMETERS	SYMBOL	MIN	TYP	MAX	UNIT	TEST CONDITIONS
Output Power	$P_o$		0.475	0.7	mW	$I = I_F^{(1)}$
Wavelength	$\lambda_p$	835	850	860	nm	$I_F = 6 \text{ mA}$
Forward Voltage	$V_F$	1.6	1.7	1.80	V	$I_F = 6 \text{ mA}$
Series Resistance	$R_S$		40	60	$\Omega$	$I_F = 6 \text{ mA}$
Breakdown voltage	$V_{BD}$	7	14		V	$I_r = 10\mu\text{A}$
Beam Divergence( $1/e^2$ )	$\theta$		8		degree	$I_F = 6 \text{ mA}$

Notes :(1) Binning

Optical power at each of following nominal bin operating current and constrained resistor at VDD=1.8 V.

Bin grade	LD current (mA)	Single Constrain resistor :R( $\Omega$ )	6 Series Constrain resistor: $r_n$ ( $\Omega$ )	Bin grade	LD current (mA)	Single Constrain resistor :R( $\Omega$ )	6 Series Constrain resistor: $r_n$ ( $\Omega$ )
P36	3.6	40.8	6.8	P44	4.4	28.2	4.7
P40	4.0	30.6	5.1	P46	4.6	25.8	4.3
P42	4.2	30.6	5.1	P48	4.8	21.6	3.6

Single constrain resistor R value = 6 series connection resistor for eye safety protection

$$R = r_1 + r_2 + r_3 + r_4 + r_5 + VR1$$

Ex. P44:  $28.2\Omega = 4.7\Omega + 4.7\Omega + 4.7\Omega + 4.7\Omega + 4.7\Omega + VR1(4.7\Omega)$ .

Optical power at each of following nominal bin operating current and constrained resistor at VDD=2.7 V.

Bin grade	LD current (mA)	Single Constrain resistor :R(Ω)	6 Series Constrain resistor: r <sub>n</sub> (Ω)	Bin grade	LD current (mA)	Single Constrain resistor :R(Ω)	6 Series Constrain resistor: r <sub>n</sub> (Ω)
P36	3.6	306	51	P50	5.0	198	33
P40	4.0	282	47	P52	5.2	180	30
P42	4.2	282	47	P54	5.4	180	30
P44	4.4	234	39	P56	5.6	162	27
P46	4.6	234	39	P58	5.8	162	27
P48	4.8	216	36	P60	6.0	132	22

Single constrain resistor R value = 6 series connection resistor for eye safety protection

$$R = r_1+r_2+r_3+r_4+r_5+VR1$$

Ex. P52:180Ω = 30Ω+ 30Ω+30Ω+30Ω+30Ω+VR1(30Ω)

**Warning! For Single constrain resistor( R ) and 6 series constrain resistor(r<sub>n</sub>), please using the recommend value, if resistor value is less than recommend value, there will be eye safety issue.**

**ABSOLUTE MAXIMUM RATINGS:**

PARAMETERS	MIN	MAX	UNIT	Condition
Storage Temperature	-30	85	°C	
Operating Temperature	-10	60	°C	
Continuous Forward Current		12	mA	
Continuous Reverse Voltage		7	V	
Lead Solder Temperature		260	°C	10 seconds

Fig. 1 Typical Optical Characteristics

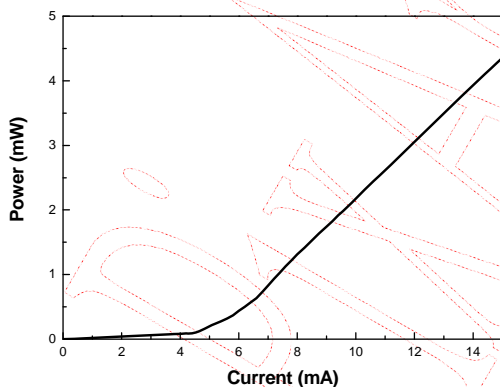
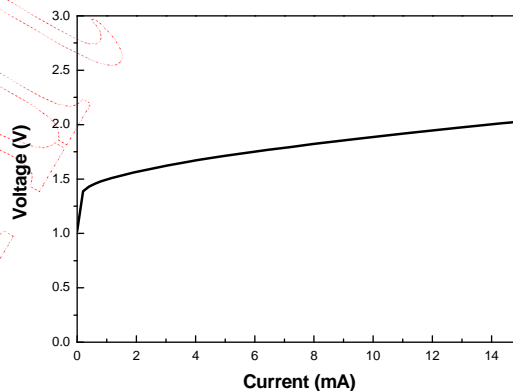
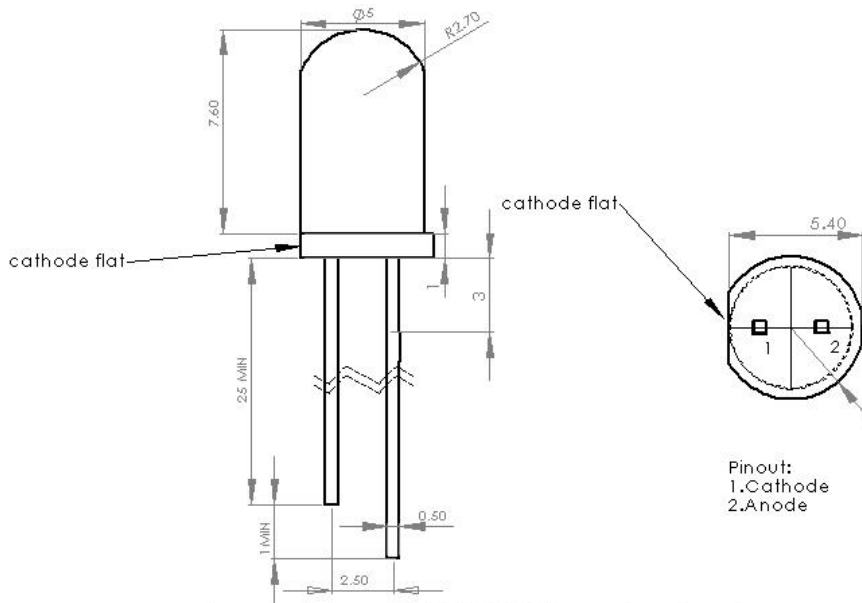

Fig. 2 Typical Electrical Characteristics



**OUTLINE DIMENSIONS:**



Note:

- 1. unit is millimeters
- 2. Tolerance is  $\pm 0.2$  mm unless otherwise notes

**WARNING:**

The VCSEL is a class IIIa laser in the safety standard ANSI Z136.1 and should be treated as a potential eye hazard.



### PNLR-00038 Lens Dimensions

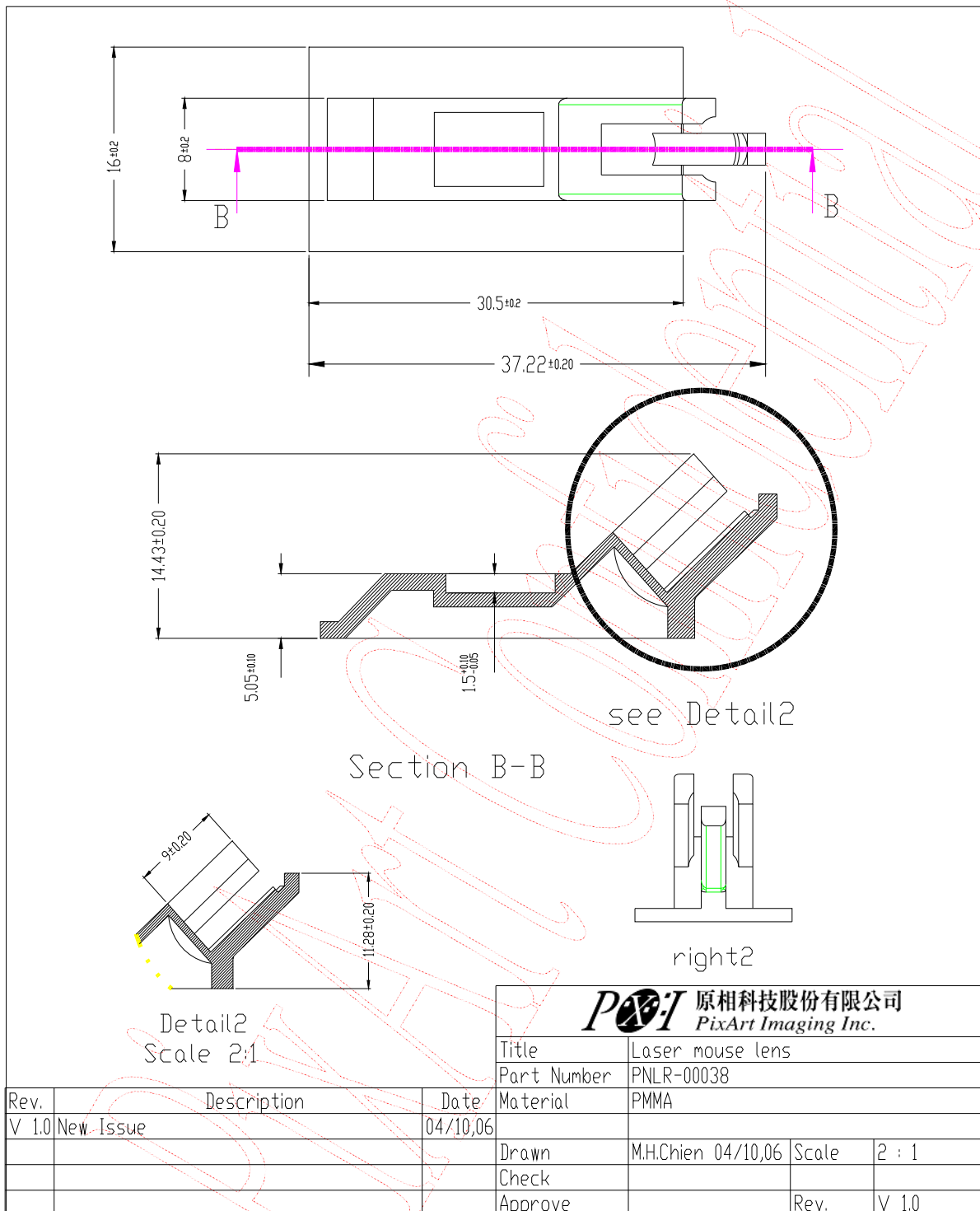

Note: The Part No. of the Mouse Product with Prefix "PAN" shall NOT be made, sold, offered to sell, imported or used in or into USA, Canada, Japan and EU. For "PAN", PixArt has only gained territory-limited patent license from Avago. Avago reserve right to take legal action against our customers who fails to comply the above term. PLEASE NOTE THAT PixArt will NOT defend, indemnify, or provide any assistance to our customers who fail to comply the term. IF YOU DO NOT AGREE THE TERM, PIXART WILL NOT DELIVER "PAN" PRODUCTS TO YOU.