

RC15005 THRU RC1510

SINGLE-PHASE SILICON BRIDGE RECTIFIER

VOLTAGE: 50-1000V

CURRENT: 15.0A

FEATURES

- Surge overload ratings-300 Amperes
- Good for printed circuit board assembly

MECHANICAL DATA

- **Case:** Silicon rubber passivated
- **Epoxy:** UL 94V-0 rate flame retardant
- **Lead:** MIL-STD- 202E, Method 208 guaranteed
- **Polarity:** As marked
- **Mounting position:** Any
- **Weight:** 1.88 grams

C-3

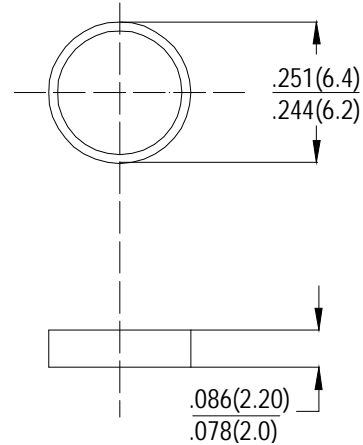

Dimensions in inches and (millimeters)

MAXIMUM RATINGS AND ELECTRICAL CHARACTERISTICS

Ratings at 25°C ambient temperature unless otherwise specified.

Single phase, half wave, 60Hz, resistive or inductive load.

For capacitive load, derate current by 20%.

	SYMBOL	RC15005	RC1501	RC1502	RC1504	RC1506	RC1508	RC1510	units
Maximum Recurrent Peak Reverse Voltage	V_{RRM}	50	100	200	400	600	800	1000	V
Maximum RMS Bridge Input Voltage	V_{RMS}	35	70	140	280	420	560	700	V
Maximum DC Blocking Voltage	V_{DC}	50	100	200	400	600	800	1000	V
Maximum Average Forward rectified Output Current at $T_A=50^\circ\text{C}$	I_o	15.0							A
Peak Forward Surge Current 8.3ms single half sine-wave superimposed on rate load (JEDEC method)	I_{FSM}	300							A
Maximum Forward Voltage Drop per element at 15.0A DC	V_F	1.0							V
Maximum DC Reverse Current at Rated DC Blocking Voltage per element	@ $T_A=25^\circ\text{C}$	5.0							μA
	@ $T_A=100^\circ\text{C}$	500							
I^2t Rating for Fusing ($t < 8.3\text{ms}$)	I^2t	10							A^2S
Typical Junction Capacitance (Note 1)	C_J	25							pF
Typical Thermal Resistance (Note 2)	$R_{\theta JA}$	40							$^\circ\text{C/W}$

Notes: 1. Measured at 1MHz and applied reverse voltage of 4.0 volts

2. Thermal Resistance from Junction to lead mounted on P.C.B with 0.47×0.47" (12×12mm) copper pads