



## PULSE/DTMF SWITCHABLE DIALLERS WITH 10 REPERTORY MEMORIES

### FEATURES

- Selectable Loop-disconnect (Pulse) or DTMF (Tone) dialling modes
- 10 x 24 Digit Repertory Dialling Stores
- 24 Digit Last Number Redial (LNR)
- Selectable Interdigit Pause (IDP) 500ms or 800ms
- Operates with inexpensive single contact keypad
- On-chip Darlington transistor pair for DTMF tone filtering
- Low power CMOS technology enables direct operation from Telephone line
- Keypad switchable Loop-Disconnect to DTMF during a call
- Selectable Break:Make Ratios 2:1 or 3:2
- Uses inexpensive 560KHz ceramic resonator
- Earth Loop Recall and Timed Break Recall (Timed Flash)
- Low on-hook Supply Current Options  
SA54X53 - 5 $\mu$ A @ 2.5V  
SA54X56 - 1 $\mu$ A @ 2.5V  
SA54X59 - 1 $\mu$ A @ 3.0V
- Call, barring/locking feature available on the SA54L5
- Optional use of external capacitor for oscillator

### PIN CONNECTIONS: SA545

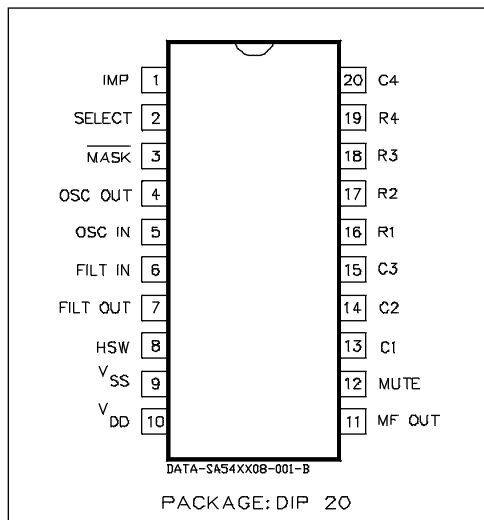

### PIN CONNECTIONS: SA54L5

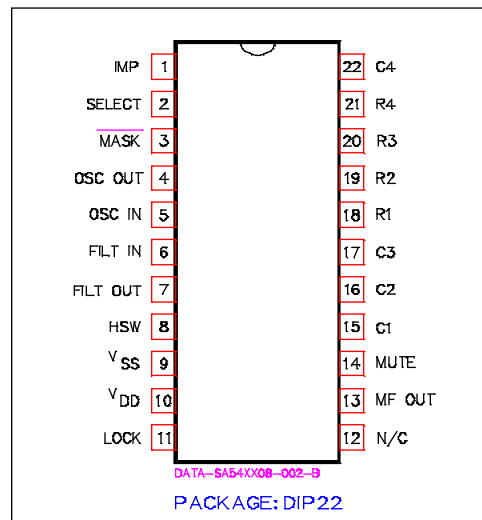

## SA545

---

### ABSOLUTE MAXIMUM RATINGS \*

Parameter	Min	Typ	Max	Unit	Notes
Supply Voltage $V_{DD} - V_{SS}$	-0,3		6,5	V	
Voltage on any pin (except HSW)	$V_{SS} - 0,3$		$V_{DD} + 0,3$	V	
Voltage on pin HSW	$V_{SS} - 0,3$			V	See Note 1
Current at any pin (except HSW, FILTOUT and FILTIN)	-1		1	mA	
Current at pin FILTOUT	0		0,1	mA	
Current at pin FILTIN	-5		0	mA	
Operating Temperature	-25		70	°C	
Storage Temperature	-55		125	°C	

\* Stresses above those listed under "Absolute Maximum Ratings" may cause permanent damage to the device. This a stress rating only. Functional operation of the device at these or any other condition above those indicated in the operation sections of this specification, is not implied. Exposure to Absolute Maximum Ratings for extended periods may affect device reliability.

Note 1: A diode is internally connected between this pin and  $V_{DD}$ . Provided current is externally limited to 300 $\mu$ A max, no damage will occur.

**DC ELECTRICAL CHARACTERISTICS**(V<sub>DD</sub> = 2,5V at 25°C, unless otherwise specified)

Condition	Min	Typ	Max	Unit	Notes
Supply voltage: on-hook off-hook	1,8 2,4		5,7 5,7	V V	For memory retention
Hookswitch input: on-hook off-hook	0,8 V <sub>DD</sub>		0,2 V <sub>DD</sub>		
Supply Current: on-hook SA54X53 SA54X56 SA54X59 off-hook MF tone sending LD impulsing		<0.2 <0.2 <0.2 1,5	5 1 1 1,0 200	μA μA μA μA mA μA	V <sub>DD</sub> = 2.5V V <sub>DD</sub> = 2.5V V <sub>DD</sub> = 3V If MF OUT is low
Output High Voltage (MASK, MUTE and IMP Outputs)	2,2			V	I = -1mA
Output Low Voltage (MASK, MUTE and IMP Outputs)			0,3	V	I = +1mA
MF OUT d.c. Level During Tone Sending		0,9V <sub>DD</sub>		V	
MF OUT Output Resistance		3		KΩ	
'Key Pressed' Resistance			2	KΩ	2,5V < V <sub>DD</sub> < 5,7V
'Key Not Pressed' Resistance	500			KΩ	2,5V < V <sub>DD</sub> < 5,7V
Darlington Pair Current Gain	600	50,000			I <sub>e</sub> = 100μA, V <sub>ce</sub> = 2V

**AC ELECTRICAL CHARACTERISTICS**(V<sub>DD</sub> = 2,5V at 25°C, unless otherwise specified)

Condition	Min	Typ	Max	Unit	Notes
Oscillating Frequency		560		kHz	
Tone Output: Low Group High Group	68	77 97	109	mVrms mVrms	No Load No Load
High-to-Low Group Amplitude Ratio	1,5	2	2,5	dB	at MF OUT
Total harmonic Distortion: 0-4KHz 0-10KHz 0-50KHz 0-200KHz		1,5 2,5 5,0 6,5	10	% % % %	

## SA545

Keypad	R1	R2	R3	R4	C1	C2	C3
Nominal frequency (Hz)	697	770	852	941	1209	1336	1477
Deviation from nominal (%)		-,07	-,10	+,19	-,15	-,17	-,20

-,22

There will be an additional error due to any deviation in the oscillator frequency from 560 kHz.

### FUNCTIONAL OVERVIEW

The SAMES SA545 is a family of keypad switchable Loop Disconnect (LD)/Dual Tone multi-Frequency (DTMF) dialler devices for use in low-cost, dual dialling mode telephone instruments.

The devices feature automatic storage of a single telephone number of up to 24 digits for Last Number Redial (LNR) purposes as well as 10 repertory dialling memories capable of each storing 24 digits. The low current consumption of the SA545 ensures memory retention while powered from the line.

Two modes of operation are available. The first is a LD/DTMF mode which operates normally in LD mode, but can be switched temporarily via the keypad to DTMF mode during a call. This mode has been optimised for applications such as home banking, credit-card verification and other applications requiring low speed data communications. The second mode allows DTMF dialling only.

The Lock function will be described in the Functional Description.

The SA545 family is pin compatible with SAMES SA541 family.

### Ordering Information

		S A 5 4 X 5 X / X
Lock Option	L : with (22 pin package) Blank : without (20 pin package)	   
On-Hook Current Option	3 : 5µA @ 2.5V 6 : 1µA @ 2.5V 9 : 1µA @ 3V	   
	Blank : MF Digits dialled after */# not stored /1 : All MF digits stored	

### Block Diagram

Figure 1 depicts the SA545 block diagram, while Table 1 lists the respective pin functions of the SA545 and SA54L5.

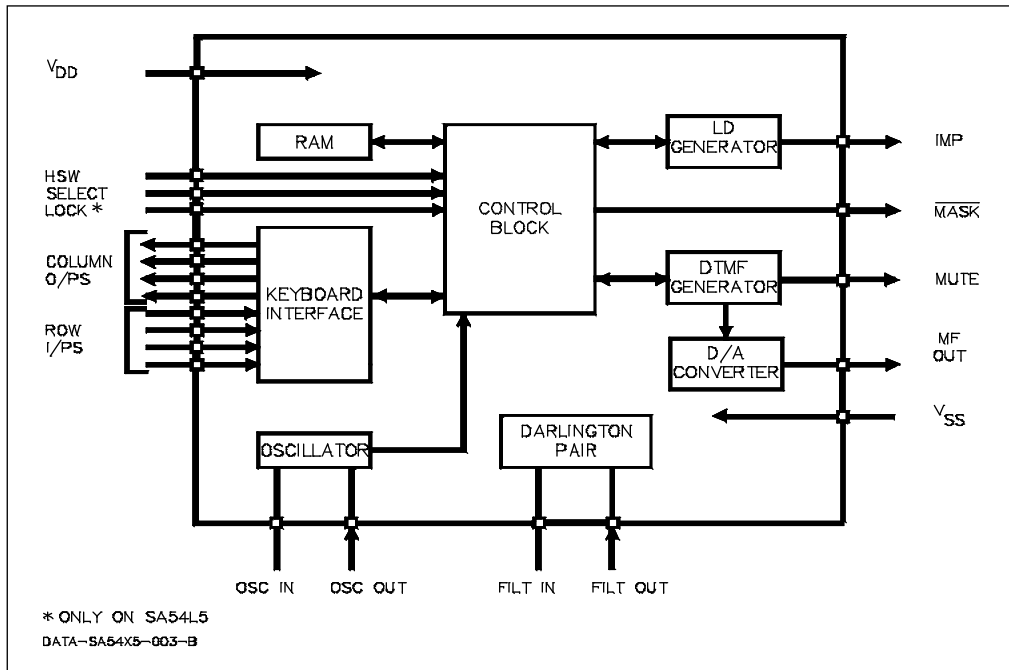

Figure 1: SA54X5 Block Diagram

## SA545

SA545	SA54L5	Designation	Description
10	10	V <sub>DD</sub>	Positive Supply input
9	9	V <sub>SS</sub>	Negative Supply input
4	4	OSC OUT	Connections for 560KHz ceramic resonator
5	5	OSC IN	
12	14	MUTE	Active high output during keying and tone transmission. (See Note 1)
3	3	$\overline{\text{MASK}}$	Output to disable speech circuit during pulse dialling and recall. (See Note 2)
6	6	FILT IN	Unity gain amplifier input and output for DTMF tone filtering
7	7	FILT OUT	
11	13	MF OUT	DTMF output
1	1	IMP	'Loop disconnect' dialling output. During dialling, a logic 1 (high level) corresponds to loop connection while a logic 0 (low level) corresponds to loop disconnection.
2	2	SELECT	LD/DTMF selection, IDP and B:M ratio programming
13	15	C1	Column output connections for 16 button single contact keypad
14	16	C2	
15	17	C3	
20	22	C4	
16	18	R1	Row input connections for 16 button single contact keypad
17	19	R2	
18	20	R3	
19	21	R4	
8	8	HSW	Hookswitch input. A logic 1 (High) applied to this input indicates an "off-hook" condition.
-	11	LOCK	Lock Input must be tied to V <sub>SS</sub> to disable all keypad keys (except TBR and LNR). Normal operation is enabled by connecting LOCK to V <sub>DD</sub> .
-	12	N/C	No connection
<p>Note 1: The MUTE output is provided to disable the microphone (via the speech network) while maintaining the loop condition during DTMF transmission.</p> <p>Note 2: The MASK output may be used to disconnect the whole speech circuit in order to maintain the break condition whilst on-hook, during a Timed Break Recall (TBR) operation or LD dialling.</p>			

**Table 1: Pin Description**

## FUNCTIONAL DESCRIPTION

**Note:** All timing data assumes the use of a 560 KHz ceramic resonator as time base.

### 1. Power On

When power is applied to the chip, a power-on reset circuit operates and ensures that the Last Number Redial (LNR) and 10 Repertory stores are cleared and all logic is reset. The power-on reset circuit is designed such that if the chip supply voltage drops to a level at which the LNR and Repertory stores may be corrupted, it will always, under all conditions, clear the stores when power is restored, so that corrupt data is not retained.

### 2. Hookswitch Operation

The HSW input is used to inform the SA545 of whether the telephone is on-hook or off-hook. Logic '0' is recognised as on-hook, Logic '1' is recognised as off-hook. When the HSW input rises from '0' to '1' the off-hook state is recognised immediately and keypad inputs are accepted. However, when the HSW input falls from '1' to '0' the on-hook state is not recognised for 200-300ms. This ensures that short line breaks of less than 200ms, such as line reversals applied by the exchange, are ignored. In this case, the MASK and IMP outputs will go low immediately the HSW input goes low in order to preserve current, but will resume normal operation immediately HSW goes high.

**On-hook state:** In the on-hook state all chip outputs are set low, the oscillator circuit is inhibited and no key inputs are accepted. This conserves supply current so that the LNR and Repertory stores contents may be retained.

**Off-hook state:** When the HSW input goes high, the MASK output immediately goes to the logic '1' level and remains there until dialling starts (see Figure 5). COLUMN outputs also go high until a key is pressed. The oscillator circuit remains inactive until a key is pressed, and is normally off whenever timing functions are not required, hence reducing operating current.

### 3. Keypad Operation

A single contact, normally open keypad is required. When off-hook the COLUMN outputs are normally held high and the ROW inputs are low (via internal pull-down resistors). When a key is pressed, a COLUMN output is connected to a ROW input, pulling the latter high.

This action initiates keyboard scanning. During keyboard scanning, the COLUMN outputs are normally low but generate scanning pulses at 7ms intervals on each output, in sequence. A key is accepted as valid when two successive scanning pulses from the same COLUMN are seen on a ROW input. Hence, the minimum bounce-free key closure period which is necessary to guarantee detection is 14ms(plus the oscillator start up time if it was not already running).

## SA545

**Simultaneous Key Depressions:** If two keys are pressed simultaneously (i.e. a second key is pressed before the first has been verified), neither key will be accepted until both keys are released and the correct key is pressed again.

Table 2 indicates the keypad layout for the SA54X5 family.

	C1	C2	C3	C4
R1	1	2	3	TBR
R2	4	5	6	REDIAL
R3	7	8	9	STORE
R4	*	0	#	PAUSE

TBR: Timed Break Recall (Flash)  
REDIAL: Last Number and Repertory Store Redial  
STORE: Enters digits into a Repertory Store  
PAUSE: Enters a pause into a Repertory Store

**Table 2: Keypad Layout**

#### 4. Dialling Mode Selection

The dialling mode may be selected via the SELECT pin (pin 2) as detailed in Table 3. Four Loop-Disconnect options are available with different Interdigit pauses (IDP) and Break:Make ratios. If the DTMF mode is selected, dialling will remain fixed in the DTMF mode. However, if one of the LD modes is selected, the chip will be in LD mode in the initial off-hook condition, but may be switched to DTMF by pressing either the \* or # keys, provided that dialling is not in progress. If the \* or # keys are pressed during LD dialling, they will be ignored.

Once in DTMF mode, depression of either the \* or # keys will cause the relevant tone-pair to be output. Only digits entered prior to a DTMF switchover will be stored and available for redialling (see Last Number Redial operation).

Once switched to DTMF, dialling will remain in this mode until either a Recall (Flash) operation or until the device returns to the on-hook state.

Select (Pin 2) Connected to:	Dialling Mode	IDP(ms)	B:M Ratio
V <sub>SS</sub>	LD	800	2:1
C1	LD	500	2:1
C2	LD	500	3:2
C3	LD	800	3:2
V <sub>DD</sub>	DTMF		

**Table 3: Dialling Mode Selection**



**5. Last Number Redial (LNR)**

The function of the on-chip LNR store is to automatically retain a manually dialled number for redialling later. The capacity of the store is 24 digits. If a number longer than 24 digits is dialled, redialling will be inhibited.

The LNR store has two features designed to assist the user, viz: Moving Cursor Facility and Mixed Mode Dialling.

**Moving Cursor Facility:** This facility is provided to aid use in PABX applications, where the user must first dial an access digit or digits, and then wait for a second dial-tone before continuing dialling.

If the first digit(s) of a new number dialled match the contents of the LNR store, then pressing LNR (redial button twice) will dial out the remaining digits. If there is a mismatch in the number then redial is inhibited until the next on-hook and the LNR store will contain the new number. If the user manually dials the first digit(s) matching those stored in LNR, and then goes on-hook, the whole contents of the store will be retained.

**Mixed Mode Dialling:** In the case of a call which starts in LD mode and is switched by the user (via the\* or # keys) to DTMF mode, only the digits dialled in LD mode will be retained. Provided that the number of digits dialled in LD mode does not exceed 24, the digits will be retained regardless of the number of DTMF digits entered subsequently.

**6. Repertory Dialling (10 Numbers)**

The SA545 provides 10 repertory stores each of which is 24 digits in length. Any attempt to store a number greater than 24 digits, will cause the store to be automatically cleared. No further digits will be accepted into the store until the whole programming operation is repeated.

**To programme a repertory store:** (At any time while off-hook and not dialling.)

1. Press the STORE key
2. Press the number (0-9) of the store to be programmed
3. Enter digits to be stored (No digits will be dialled while programming)
4. Either press the STORE key again or go on-hook to close the store
5. Repeat to programme other stores

**Notes:**

- i) Only valid keys will be accepted while a store is being programmed (e.g. if REDIAL is pressed while programming a store, it will be ignored).
- ii) Dual mode (i.e. LD and DTMF) numbers should be programmed into the store using the procedure outlined under 'Dialling Mode Selection'. When redialling from a repertory store, if an LD/DTMF mode change is encountered, dialling will halt (and the speech circuit will be reactivated) until told to continue by the user. It should be noted that if a mode change is entered into a repertory store, it will require one store location.
- iii) Pauses may be stored in repertory stores.  
This is achieved by pressing the PAUSE key while programming the store. When redialling from a repertory store, and a pause is encountered, dialling will halt (the speech circuit will be reactivated) until told to continue by the user. A pause will require one store location.

**To dial a number from a repertory store:** (Whilst off-hook and not already dialling)

- 1. Press the REDIAL key once
- 2. Press the number (0-9) of the store to be dialled  
Dialling will now start
- 3. If dialling halts due to an LD to DTMF mode change or a pause instruction, further dialling will be resumed by pressing the REDIAL key or the PAUSE key.  
(Alternatively, pulling C4 low for a minimum of 14ms will have the same effect).

**Notes:**

- i) If an LD/DTMF mode change instruction is encountered while dialling from a repertory store, dialling will halt. If further dialling from this store is invoked (as described above) it will be in DTMF mode.
- ii) Digits may be dialled manually, or a Last Number Redial carried out before dialling from a repertory store. In this case, when repertory dialling is invoked, it will commence in the mode that was current immediately before repertory dialling was invoked.
- iii) Further dialling (either manual or repertory) is allowed after repertory dialling. Subsequent dialling will commence in the same mode of the last digit dialled from the repertory store (even if dialling halted at an LD/DTMF switchover).
- iv) If an LD/DTMF switchover is stored in the first location of a repertory store, the following digits will be dialled in DTMF without first halting.
- v) All key inputs will be ignored whilst a number is being dialled from a repertory store. Only when dialling has stopped, will further key inputs be recognised.

### 7. Earth Loop Recall (ELR) / Timed Break Recall (TBR) (Timed Flash)

The SA545 supports both TBR and ELR and offers a common operating protocol in both cases.

After a Recall (Flash) operation, the dialling mode selected via the SELECT pin will be restored. Only the digits dialled after the ELR/TBR operation will be retained in the LNR store.

A TBR of 100ms<sup>1)</sup> is generated when the TBR key is pressed. The  $\overline{\text{MASK}}$  output goes low in order to produce the line break. When in DTMF mode, the MF OUT output also goes low for the duration of the break.

ELR is supported via the C3 pin. If this pin is connected to ground for a minimum of 20ms during an ELR operation, the chip will offer the same operating protocol as for TBR.

The ELR function may be achieved by use of the circuit shown in Figure 2, or by use of a double contact switch.

- 1) Other periods available on request.

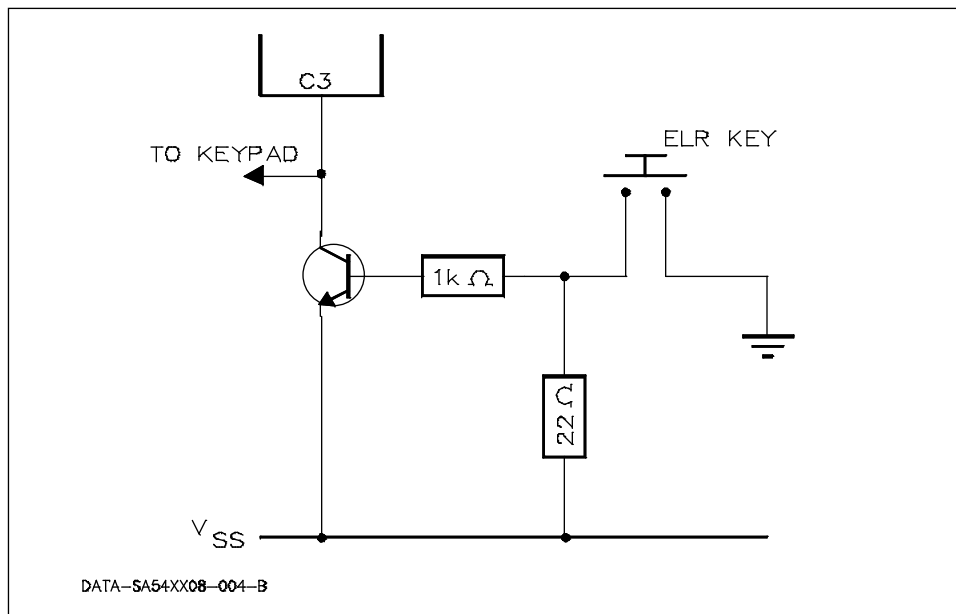

**8. Oscillator Circuit**

This requires an external 560KHz ceramic resonator connected between OSC IN and OSC OUT, providing a timing reference for all chip functions.

Consult your resonator supplier for recommendation of a suitable resonator type.

**9. Tone Filtering**

The spectral purity of the DTMF output is sufficient for most applications. However, where lower distortion DTMF tones are required, an on-chip Darlington pair is provided (accessible via pins 6 & 7) for use in a low pass active filter.

Figure 3 shows how a 2-pole Sallen and Key filter may be implemented. The typical component values have been chosen to give a second order Butterworth response with a cut-off frequency of about 3,5KHz and a nominal pass-band insertion loss of 0,5dB. The relative values of R3 and R4 may be adjusted to achieve the desired DTMF amplitude which varies with supply voltage.

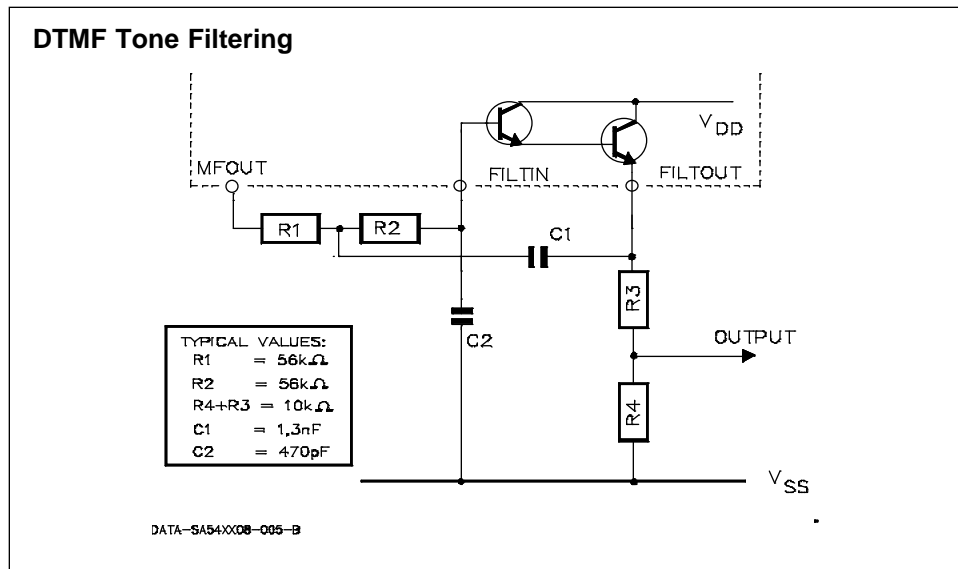

**Figure 3: 2-Pole Sallen and Key Filter Circuit**

#### 10. DTMF Dialling (Figure 4)

During DTMF dialling, the MUTE output goes to logic '1' and remains there for the duration of the tone transmission. The IMP output remains low during tone transmission. The MF OUT output rises to its d.c. level of  $0,9 V_{DD}$  at the start of the tone transmission and is kept there between tone bursts. This is to avoid transients at the beginning and end of tone bursts.

The maximum rate at which tones are sent to line is 100ms on, followed by 100ms off. If keys are activated faster than this, they are placed in a temporary store and then sent to line at the maximum rate. Dialling from the LNR store occurs at the maximum rate.

If a key is held down for longer than 100ms, the tone output will continue until the key is released.

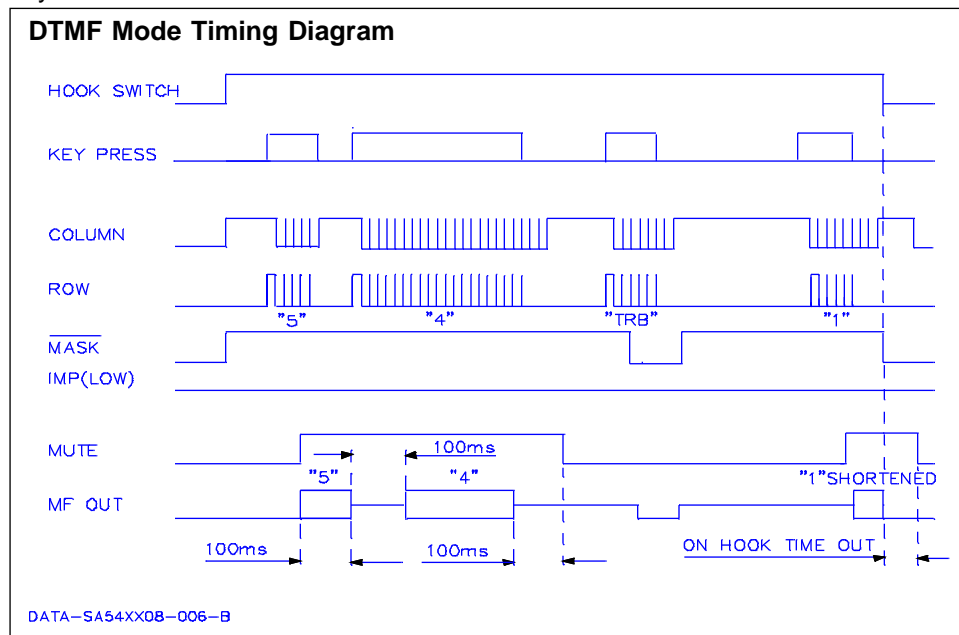
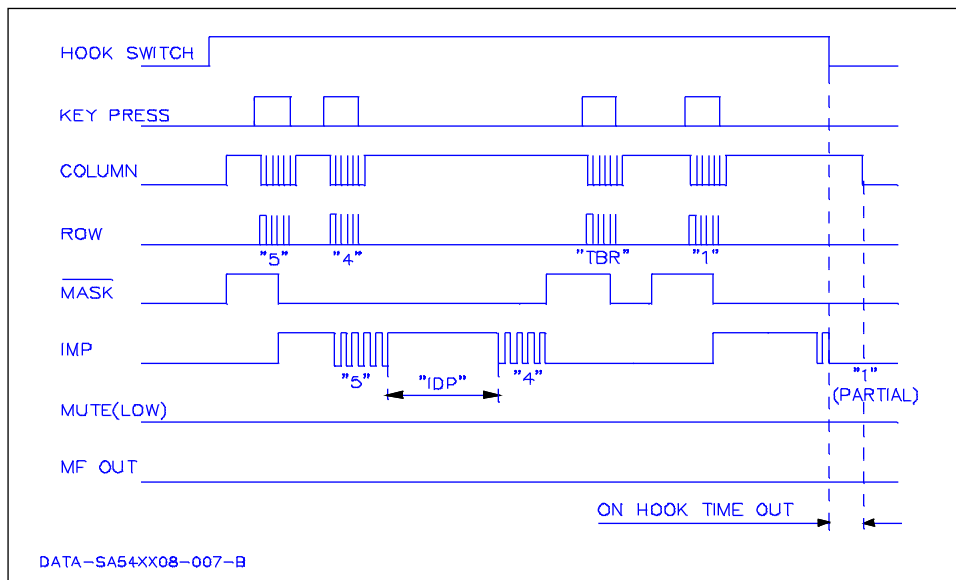

Figure 4: DTMF Mode Timing Diagram

**11. Loop Disconnect Dialling (Figures 5 and 6)**

The MASK output is provided in order to disable the speech circuit during LD dialling. Consequently, the MASK output is normally at logic '1' in the off-hook condition, but changes to logic '0' during LD dialling. MASK also changes to logic '0' in order to signal a Timed Break Recall (Flash) to the line. Both MUTE and MF OUT remain low during LD dialling.

LD dialling is signalled on the IMP output. A break is signalled by a logic '0', make periods and IDP times are signalled by a logic '1'. When not dialling, the IMP output remains at logic '0'.



**Figure 5: LD Mode Timing Diagram**

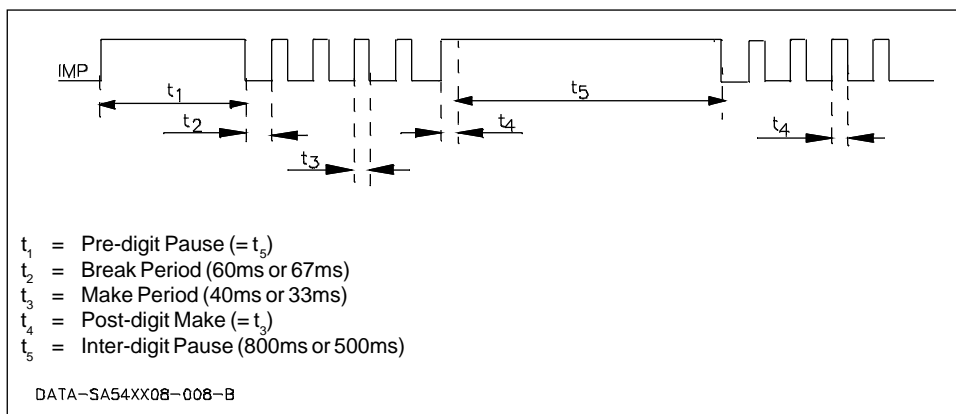

**Figure 6: Detailed Timing for IMP Output**

**12. LOCKING FACILITY**

This feature is available on the SA54L5. Pin 11 (LOCK) should be connected to  $V_{SS}$  if the device is to be locked and to  $V_{DD}$  if the device is to be unlocked. This feature can be controlled by an inexpensive low voltage SPDT switch. When locked it is impossible to dial out any number other than those stored in the LNR and repertory memory. If the redial key is pressed twice while in the locked state the number in the LNR store will be dialled out. To dial from the repertory memory while in the locked state the redial key is pressed once followed by the number (0-9) of the store to be dialled.

**13. OPTIONS**

The SA545 has been designed to allow the telephonic manufacturer to cater for different market requirements. The device can be programmed, on request, at the final manufacturing stage so as to enable various attractive options. These options are listed below and are available in any combination. The standard options are listed first in Italics.

**A. Packaging****SA545**

- a) *20 pin DIP*
- b) 18 pin DIP (filter not bonded out)
- c) Other packages available on request (e.g. SO,LCC)

**SA54L5**

- a) *22 pin DIP*
- b) 20 pin DIP (filter not bonded out)
- c) Other packages on request

**B. TBR (Flash) Period****SA545 and SA54L5**

- a) *100ms*      d) 600ms
- b) 200ms
- c) 300ms

**C. TBR (Flash) LNR Protocol**

- a) Number after the TBR is retained in LNR store.
- b) *Number before the TBR is retained in the LNR store.*

**D. PIN 3**

- a) *MASK*
- b) MASK

**E. PIN 1**

- a) *IMP*
- b) *IMP*
- c) *IMP + MASK*
- d) *IMP + MASK*

## SA545

---

### F. PIN 12 (SA545)/PIN 14 (SA54L5)

- a)  $MUTE$
- b)  $\overline{MUTE}$

### G. LNR Protocol

- a) *Numbers entered after \* or # are never retained in the LNR store. (Attractive for banking applications since PIN is not retained).*
- b) Numbers entered after \* or # are retained in the LNR store if initial mode is set to DTMF.

### TYPICAL APPLICATIONS

The circuit in Figure 7 uses a constant current supply to draw current from the telephone line which is used to power the SA54X5. The 2,5V reference diode produces a stabilised supply voltage which determines the DTMF tone level of the SA545.

In Figure 8, a stabilising voltage from the speech circuit is used to supply the SA545 during DTMF dialling to give accurate tone levels.

The SA545 is powered via the 150K $\Omega$  resistor during TBR operations and LD dialling breaks, and via T1 during dialling makes. This configuration minimises the component count, at the expense of allowing a leakage current of about 450 $\mu$ A during dialling breaks. The 47 $\mu$ F reservoir capacitor maintains and smoothes the supply to the chip.



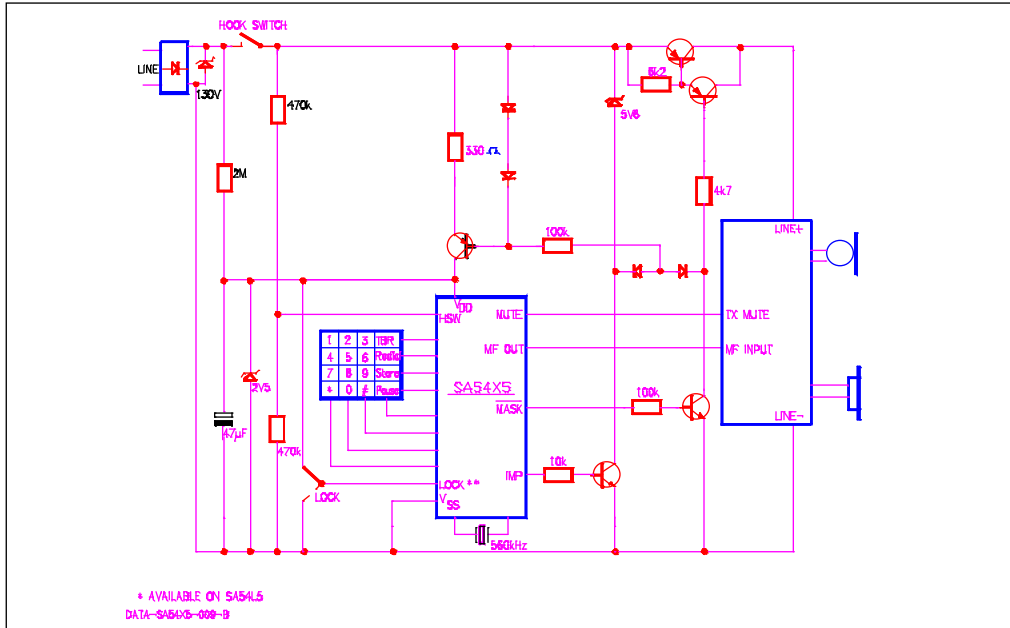

Figure 7: Typical Application Circuit: Powered via Reference Diode

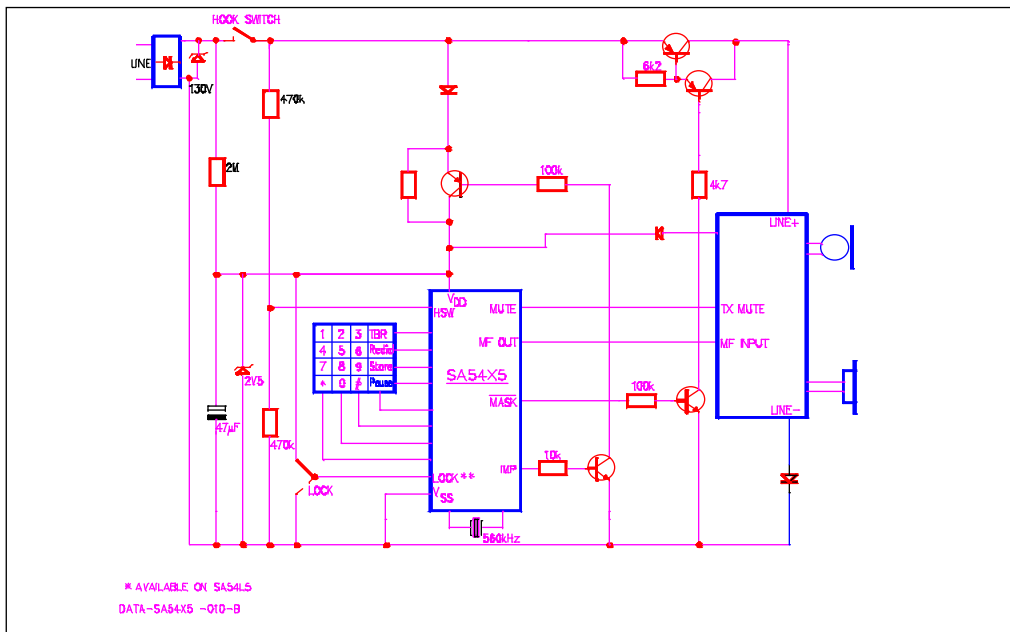

Figure 8: Typical Application Circuit: Powered via Speech Circuit

**Disclaimer:** The information contained in this document is confidential and proprietary to South African Micro-Electronic Systems (Pty) Ltd ("SAMES") and may not be copied or disclosed to a third party, in whole or in part, without the express written consent of SAMES. The information contained herein is current as of the date of publication; however, delivery of this document shall not under any circumstances create any implication that the information contained herein is correct as of any time subsequent to such date. SAMES does not undertake to inform any recipient of this document of any changes in the information contained herein, and SAMES expressly reserves the right to make changes in such information, without notification, even if such changes would render information contained herein inaccurate or incomplete. SAMES makes no representation or warranty that any circuit designed by reference to the information contained herein, will function without errors and as intended by the designer.

**South African Micro-Electronic Systems (Pty) Ltd**

P O Box 15888,  
Lynn East,  
0039  
Republic of South Africa,

21 Eland Street,  
Koedoespoort Industrial Area,  
Pretoria,  
Republic of South Africa

Tel: 012 333-6021  
Fax: 012 333-8071

Tel: Int +27 12 333-6021  
Fax: Int +27 12 333-8071