

FEATURES

- Low forward voltage drop
- High current capability
- High reliability
- High surge current capability
- Lead (Pb)-free component
- Component in accordance to RoHS 2011/65/EU
- High temperature soldering guaranteed: 260°C/10 seconds at terminals

MECHANICAL DATA

- Case: JEDEC DO-41 molded plastic body
- Terminal: Plated axial leads, solderable per MIL-STD-750, method 2026
- Polarity: Color band denotes cathode end
- Weight: 0.012 ounce, 0.33 gram

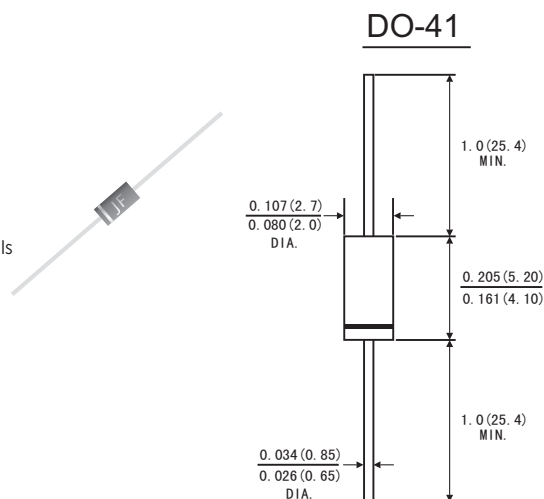

Dimensions in inches and (millimeters)

MAXIMUM RATINGS AND ELECTRICAL CHARACTERISTICS

(Rating at 25 °C ambient temperature unless otherwise specified ,Single phase ,half wave ,60HZ, resistive or inductive load. For capacitive load, derate current by 20%.)

	Symbols	SF 11	SF 12	SF 13	SF 14	SF 15	SF 16	SF 17	SF 18	Units
Maximum Repetitive Peak Reverse Voltage	V_{RRM}	50	100	150	200	300	400	500	600	Volts
Maximum RMS Voltage	V_{RMS}	35	70	105	140	210	280	350	420	Volts
Maximum DC Blocking Voltage	V_{DC}	50	100	150	200	300	400	500	600	Volts
Maximum Average Forward Rectified Current	$I_{(AV)}$	1.0								Amps
Peak Forward Surge Current 8.3ms single half sine-wave superimposed on rated load (JEDEC Method)	I_{FSM}	30								Amps
Maximum Instantaneous Forward Voltage at 1.0 A	V_F	0.95				1.3		1.7		Volts
Maximum DC Reverse Current At Rated DC Blocking Voltage	$T_A=25^{\circ}C$	5.0								μA
	$T_A=125^{\circ}C$	100								
Maximum Reverse Recovery Time(Note1)	T_{rr}	35								ns
Typical Junction Capacitance(Note2)	C_j	30				15				pF
Typical Thermal Resistance(NOTE3)	$R_{\theta JA}$	50								$^{\circ}C/W$
Operating Junction Temperature Range	T_J	-55 to +125								$^{\circ}C$
Storage Temperature Range	T_{STG}	-55 to +150								$^{\circ}C$

Note: 1. Reverse Recovery Test conditions: $I_F=0.5A, I_R=1.0A, I_{RR}=0.25A$.

2. Measured at 1MHz and applied reverse voltage of 4.0 Volts.

3. Mount on 5mmX5mm Cu-Pad on PCB.

RATINGS AND CHARACTERISTIC CURVES SF11 THRU SF18

FIG.1-MAXIMUM AVERAGE FORWARD CURRENT DERATING

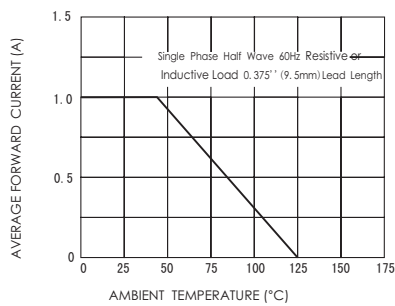

FIG.2-MAXIMUM NON-REPETITIVE FORWARD SURGE CURRENT

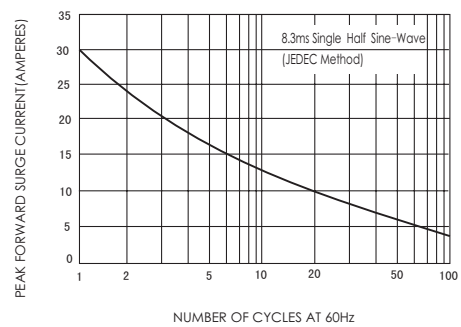

FIG.3-TYPICAL FORWARD CHARACTERISTICS

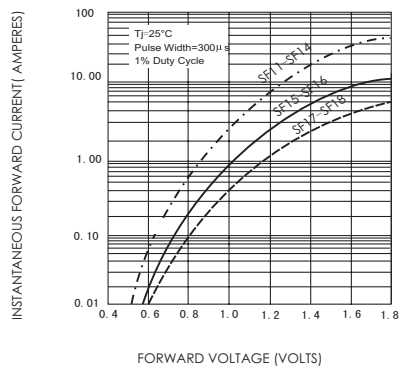

FIG.4-TYPICAL REVERSE CHARACTERISTICS

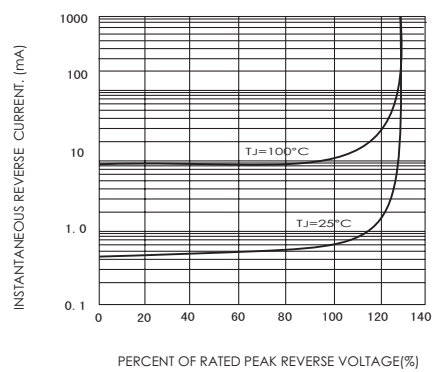

FIG.5-TYPICAL JUNCTION CAPACITANCE

