

Description

The SLVU2.8 is designed to protect low voltage, CMOS semiconductors from transients caused by electrostatic discharge (ESD), cable discharge events (CDE), lightning and other induced voltage surges. Low capacitance compensation diode is integrated into the TVS to lower the typical capacitance to 0.6pF per line. The SLVU2.8 complies with the IEC 61000-4-2 (ESD) standard with $\pm 30\text{kV}$ air and $\pm 30\text{kV}$ contact discharge. The combination of low leakage, signal integrity and flow through design makes the SLVU2.8 an ideal application such as 10/100/1000 Ethernet.

Features

- 280W peak pulse power (8/20 μs)
- Ultra low leakage: nA level
- Low operating voltage: 2.8V
- Very low capacitance: 0.6pF
- Ultra low clamping voltage
- JEDEC SO-8 package
- Complies with following standards:
 - IEC 61000-4-2 (ESD) immunity test
 - Air discharge: $\pm 30\text{kV}$
 - Contact discharge: $\pm 30\text{kV}$
 - IEC61000-4-5 (Lightning) 18A (8/20 μs)
- RoHS Compliant

Mechanical Characteristics

- Package: SOT-23
- Lead Finish: Matte Tin
- Moisture Sensitivity: Level 3 per J-STD-020
- Terminal Connections: See Diagram Below
- Marking Information: See Below

Applications

- Base Station
- Analog Inputs
- Switch Systems
- 10/100/1000 Ethernet
- WAN/LAN Equipment
- Desktops, Servers, and Notebooks
- Low Voltage Interfaces

Marking Information

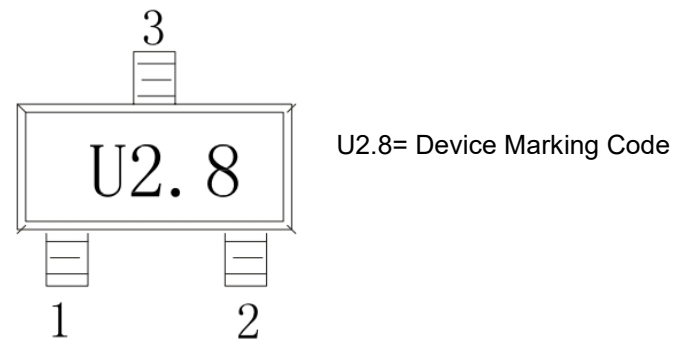

Dimensions and Pin Configuration

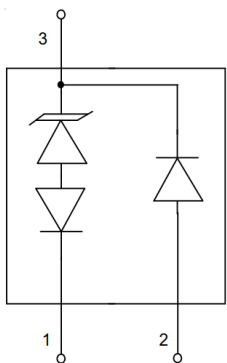

Circuit and Pin Schematic

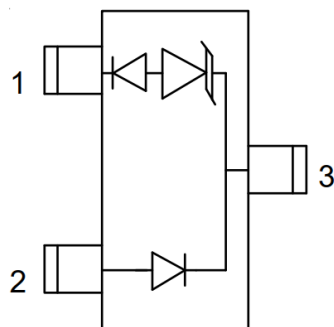

SOT23 (Top View)

Ordering Information

Part Number	Packaging	Reel Size
SLVU2.8	3000/Tape & Reel	7 inch

Absolute Maximum Ratings ($T_A=25^{\circ}\text{C}$ unless otherwise specified)

Parameter	Symbol	Value	Unit
Peak Pulse Power (8/20 μs)	Ppk	280	W
Peak Pulse Current (8/20 μs)	I _{PP}	18	A
ESD per IEC 61000-4-2 (Air) ESD per IEC 61000-4-2 (Contact)	V _{ESD}	± 30 ± 30	kV
Operating Temperature Range	T _J	-55 to +125	$^{\circ}\text{C}$
Storage Temperature Range	T _{stg}	-55 to +150	$^{\circ}\text{C}$

Electrical Characteristics ($T_A=25^{\circ}\text{C}$ unless otherwise specified)

Parameter	Symbol	Min	Typ	Max	Unit	Test Condition
Reverse Working Voltage	V _{RWM}			2.8	V	Pin 3 or Pin 2 to Pin 1
Breakdown Voltage	V _{PT}	3.0			V	I _{PT} = 2 μA , Pin 3 to 1
	V _{BR}	3.5			V	I _T = 1mA , Pin 3 to 1
	V _{SB}	3.8			V	I _{SB} = 50mA , Pin 3 to 1
Reverse Leakage Current	I _R			1	μA	V _T = V _{RWM}
Clamping Voltage	V _C			7	V	I _{PP} = 1A (8 x 20 μs pulse)
Clamping Voltage	V _C			15.5	V	I _{PP} = 18A (8 x 20 μs pulse)
Junction Capacitance	C _J		0.6	1	pF	V _R = 0V, f = 1MHz

Typical Performance Characteristics ($T_A=25^\circ\text{C}$ unless otherwise Specified)

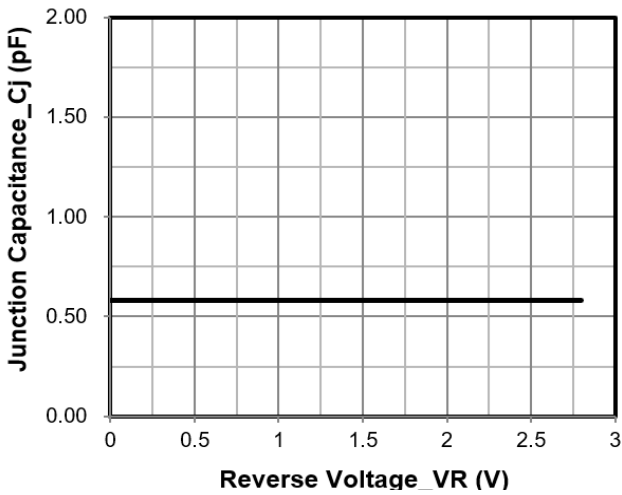

Junction Capacitance vs. Reverse Voltage

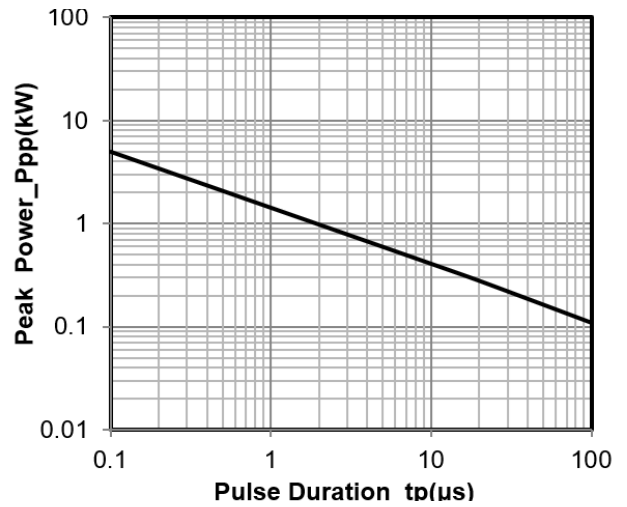

Peak Pulse Power vs. Pulse Time

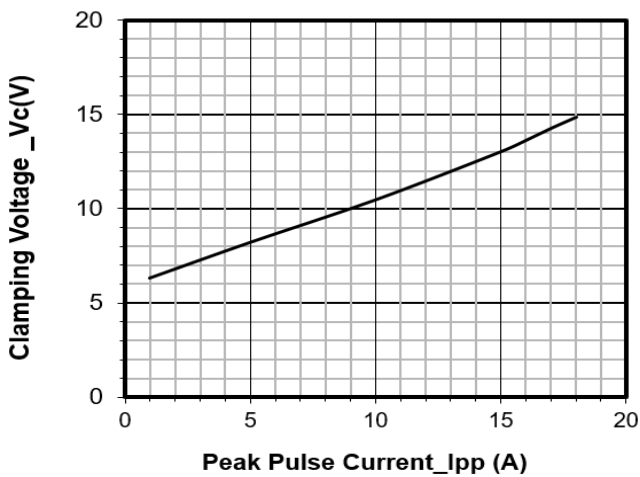

Clamping Voltage vs. Peak Pulse Current

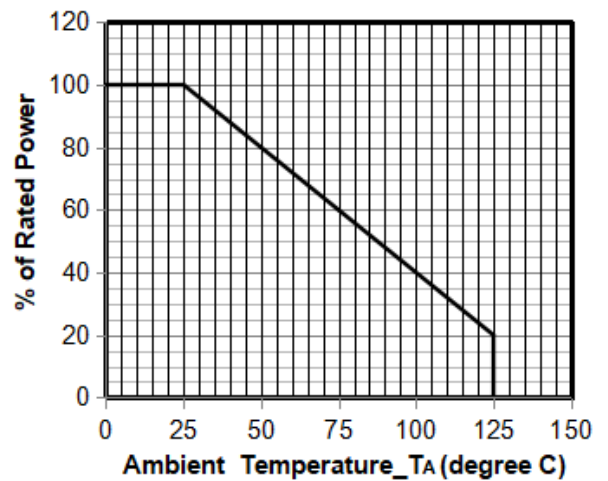

Power Derating Curve

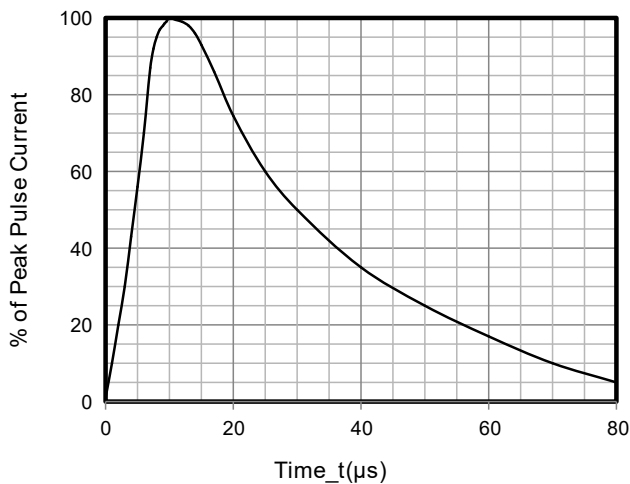

8 X 20 μs Pulse Waveform

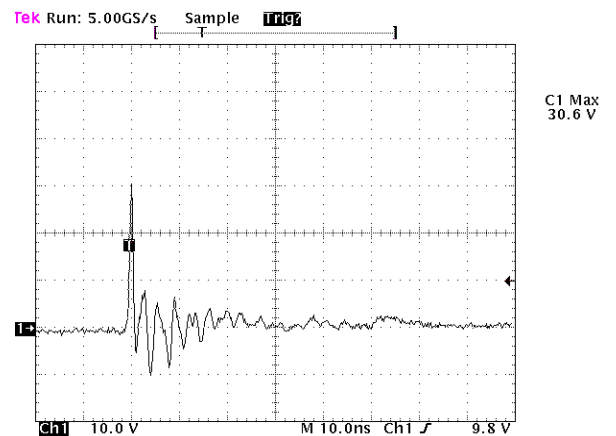

Note: Data is taken with a 10x attenuator

**ESD Clamping Voltage
8 kV Contact per IEC61000-4-2**

SOT-23 Package Outline Drawing

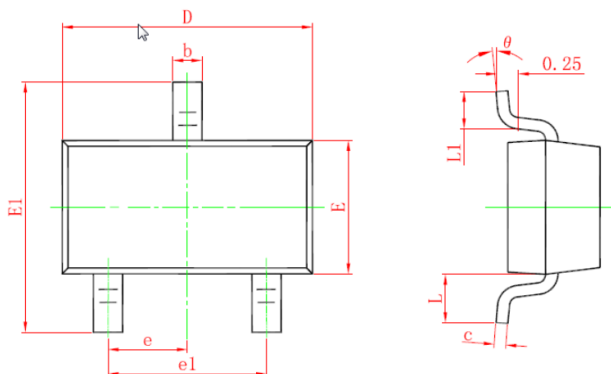

SYM	DIMENSIONS					
	MILLIMETERS			INCHES		
	MIN	NOM	MAX	MIN	NOM	MAX
A	0.90	--	1.15	0.035	--	0.045
A1	0.00	--	0.10	0.000	--	0.004
A2	0.90	--	1.05	0.035	--	0.041
b	0.30	--	0.50	0.012	--	0.020
c	0.08	--	0.15	0.003	--	0.006
D	2.80	--	3.00	0.110	--	0.118
E	1.20	--	1.40	0.047	--	0.055
E1	2.25	--	2.55	0.089	--	0.100
e	0.95TYP			0.037TYP		
e1	1.80	--	2.00	0.071	--	0.079
L	0.55REF			0.022REF		
L1	0.30	--	0.50	0.012	--	0.020
Θ	0°	--	8°	0°	--	8°

Suggested Land Pattern

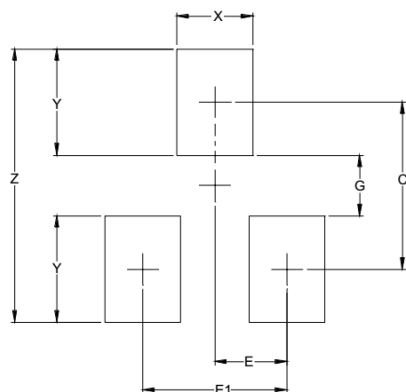

SYM	DIMENSIONS	
	INCHES	MILLIMETERS
C	(.087)	(2.20)
E	.037	0.95
E1	.075	1.90
G	.031	0.80
X	.039	1.00
Y	.055	1.40
Z	.141	3.60

Contact Information

Applied Power Microelectronics Co., Ltd.
 Website: <http://www.appliedpowermicro.com>
 Email: sales@appliedpowermicro.com
 Phone: +86 (0519) 8399 3606