

Descriptions

- High voltage application
- Telephone application

Features

- Collector-Emitter voltage : $V_{CE0} = -300V$
- Complementary pair with SPS42

Ordering Information

Type NO.	Marking	Package Code
SPS92	SPS92	T0-92

Outline Dimensions

unit : mm

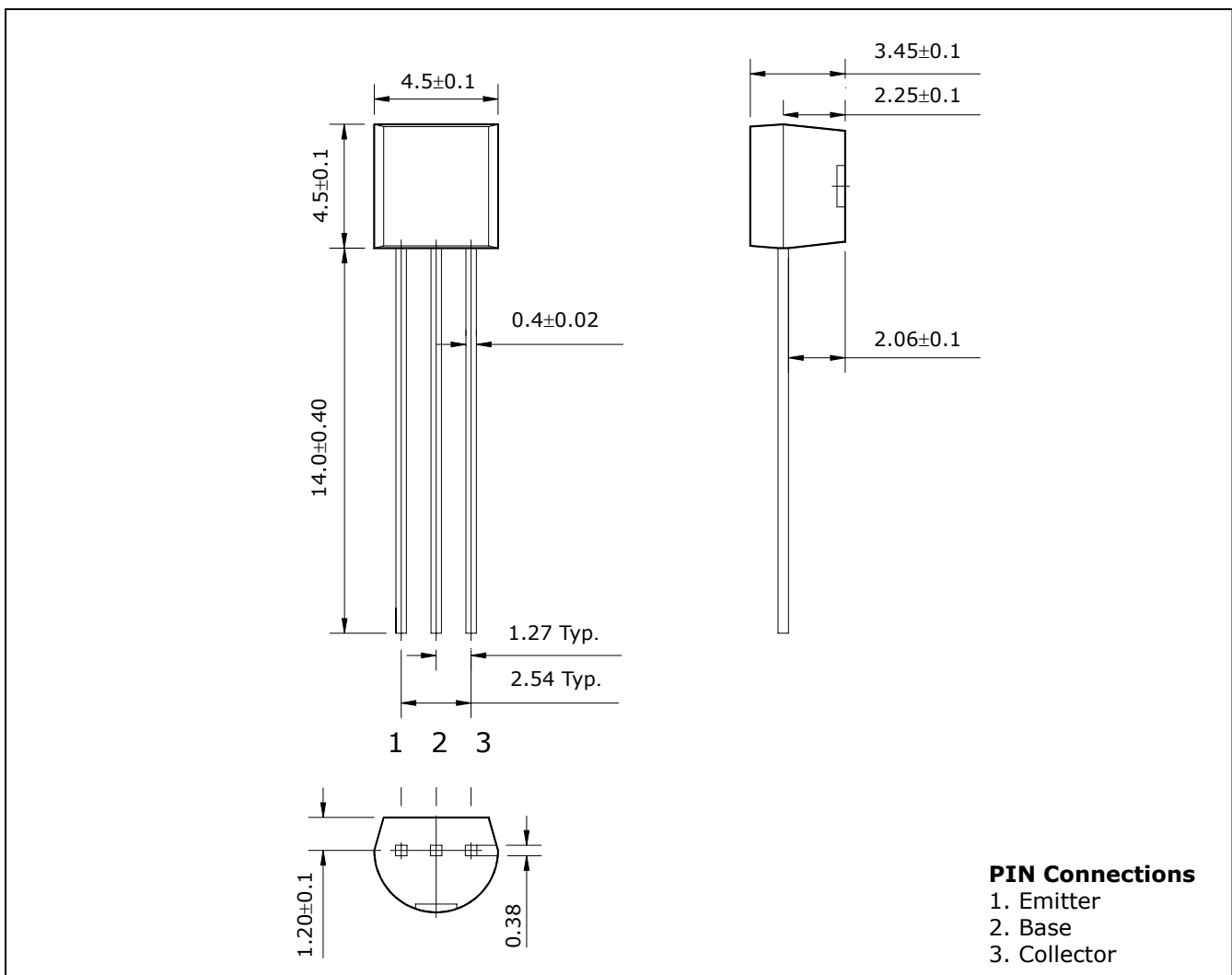

Absolute maximum ratings

(Ta=25°C)

Characteristic	Symbol	Ratings	Unit
Collector-Base voltage	V_{CBO}	-300	V
Collector-Emitter voltage	V_{CEO}	-300	V
Emitter-Base voltage	V_{EBO}	-6	V
Collector current	I_C	-500	mA
Emitter current	I_E	500	mA
Collector dissipation	P_C	625	mW
Junction temperature	T_j	150	°C
Storage temperature	T_{stg}	-55~150	°C

Electrical Characteristics

(Ta=25°C)

Characteristic	Symbol	Test Condition	Min.	Typ.	Max.	Unit
Collector-Base breakdown voltage	BV_{CBO}	$I_C = -100\mu A, I_E = 0$	-300	-	-	V
Collector-Emitter breakdown voltage	BV_{CEO}	$I_C = -1mA, I_B = 0$	-300	-	-	V
Emitter-Base breakdown voltage	BV_{EBO}	$I_E = -100\mu A, I_C = 0$	-6	-	-	V
Collector cut-off current	I_{CBO}	$V_{CB} = -200V, I_E = 0$	-	-	-0.1	μA
Emitter cut-off current	I_{EBO}	$V_{EB} = -3V, I_C = 0$	-	-	-0.1	μA
DC current gain	h_{FE}^*	$V_{CE} = -10V, I_C = -30mA$	40	-	-	-
Collector-Emitter saturation voltage	$V_{CE(sat)}^*$	$I_C = -20mA, I_B = -2mA$	-	-	-0.5	V
Base-Emitter saturation voltage	$V_{BE(sat)}^*$	$I_C = -20mA, I_B = -2mA$	-	-	-0.9	V
Transition frequency	f_T	$V_{CE} = -20V, I_C = -10mA$	50	-	-	MHz
Collector output capacitance	C_{ob}	$V_{CB} = -20V, I_E = 0, f = 1MHz$	-	-	6	pF

* : Pulse Tester : Pulse Width $\leq 300 \mu s$, Duty Cycle $\leq 2.0\%$

Electrical Characteristic Curves

Fig. 1 $h_{FE} - I_C$

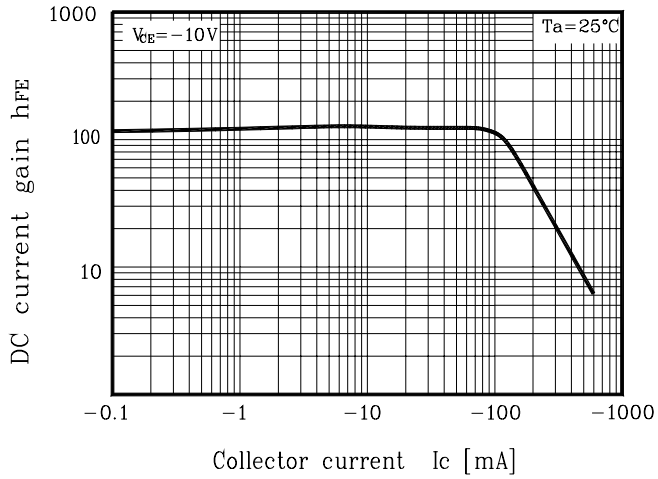

Fig. 2 $V_{CE(sat)}, V_{BE(sat)} - I_C$

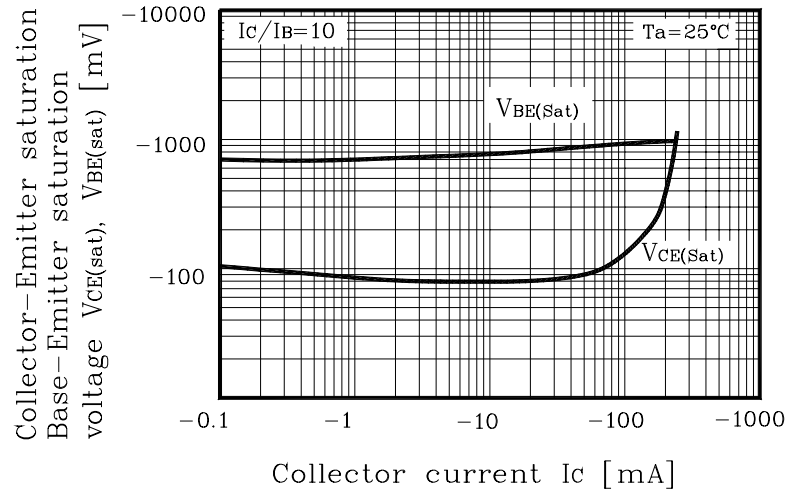

Fig. 3 $f_T - I_C$

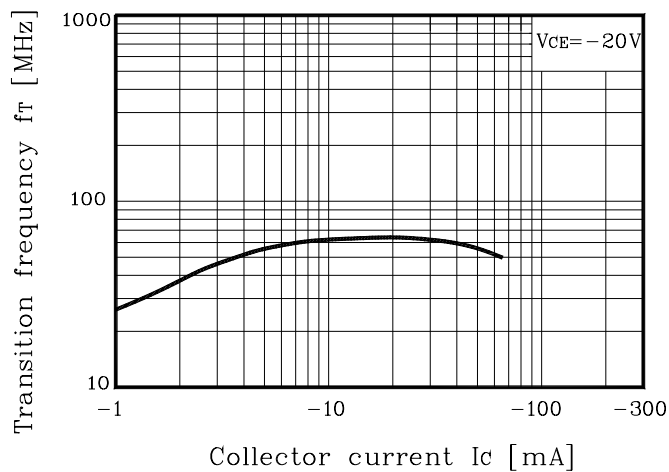

Fig. 4 $C_{ob} - V_R$

