

### Features

- Ultra low leakage: nA level
- Operating voltage: 5V
- Low clamping voltage
- Complies with following standards:
  - IEC 61000-4-2 (ESD) immunity test
    - Air discharge:  $\pm 30\text{kV}$
    - Contact discharge:  $\pm 30\text{kV}$
  - IEC61000-4-4 (EFT) 40A (5/50ns)
  - IEC61000-4-5 (Lightning) 25A (8/20 $\mu\text{s}$ )
- RoHS Compliant
- AEC-Q101 qualified.

### Dimensions SOT-26

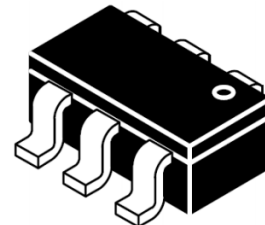

### Pin Configuration

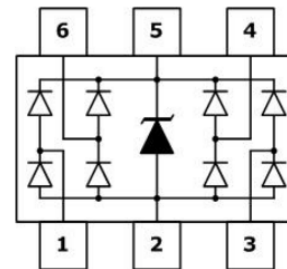

### Applications

- USB 2.0 power and data line
- Set-top box and digital TV
- Digital video interface (DVI)
- Notebook Computers
- SIM Ports
- 10/100/1000 Ethernet

### Mechanical Characteristics

- Package: SOT-26
- Lead Finish: Lead Free
- UL Flammability Classification Rating 94V-0
- Quantity Per Reel: 3,000pcs
- Reel Size: 7inch

### Absolute Maximum Ratings (Tamb=25°C unless otherwise specified)

Parameter	Symbol	Value	Unit
Peak Pulse Power (8/20 $\mu\text{s}$ )	Ppp	500	W
ESD per IEC 61000-4-2 (Air)	V <sub>ESD</sub>	$\pm 30$	Kv
ESD per IEC 61000-4-2 (Contact)		$\pm 30$	
Operating Temperature Range	T <sub>J</sub>	-55 to +125	°C
Storage Temperature Range	T <sub>STJ</sub>	-55 to +150	°C

## Electrical Characteristics (TA=25°C unless otherwise specified)

Part Number	Device Marking	V <sub>RWM</sub> (V)	V <sub>BR</sub> (V)	I <sub>T</sub> (mA)	V <sub>C</sub> @1A	V <sub>C</sub>		I <sub>R</sub> μA (Max)	C (Pf) (Typ.)
						(Max)	(@A)		
SRV05-4W	SRV05	5	6	1	12	20	25	1	1.5

## Typical Performance Characteristics ( $T_A=25^\circ\text{C}$ unless otherwise Specified)

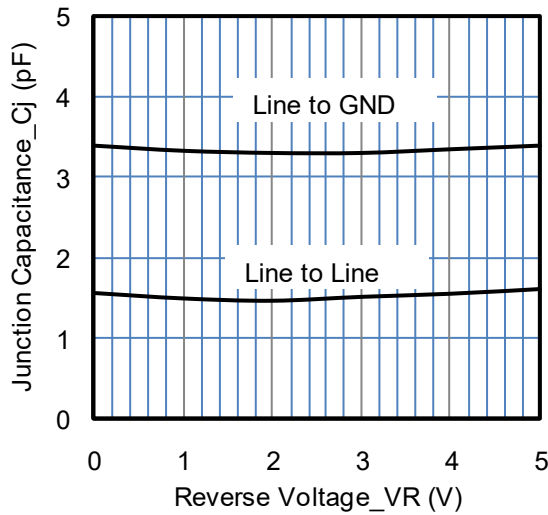

**Junction Capacitance vs. Reverse Voltage**

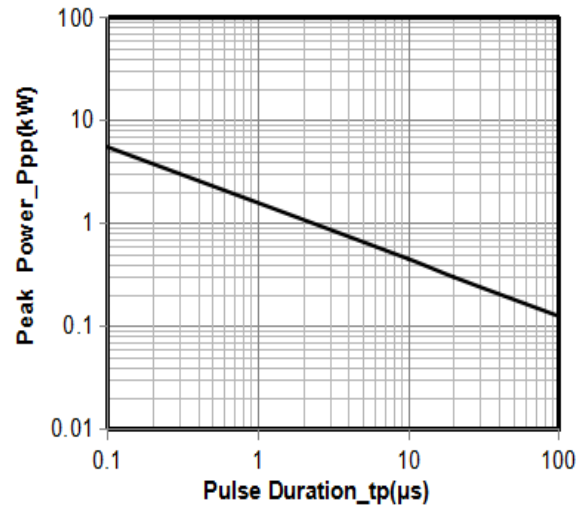

**Peak Pulse Power vs. Pulse Time**

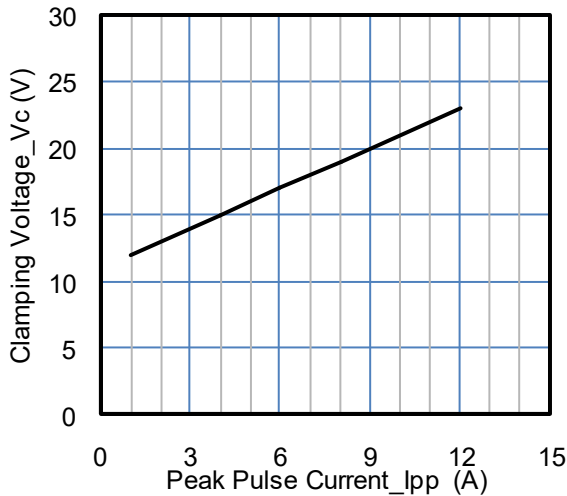

**Clamping Voltage vs. Peak Pulse Current**

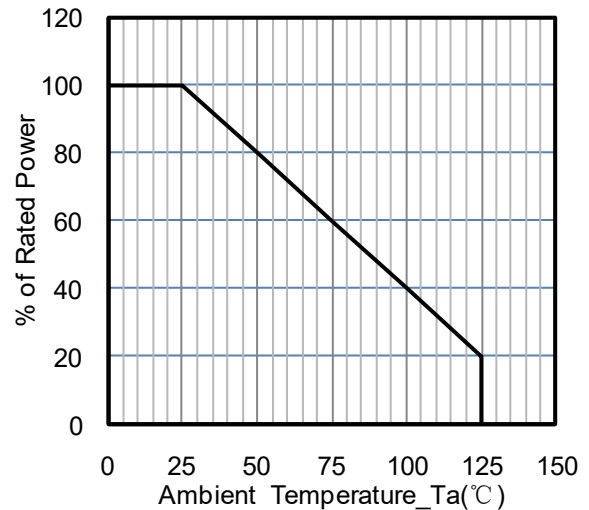

**Power Derating Curve**

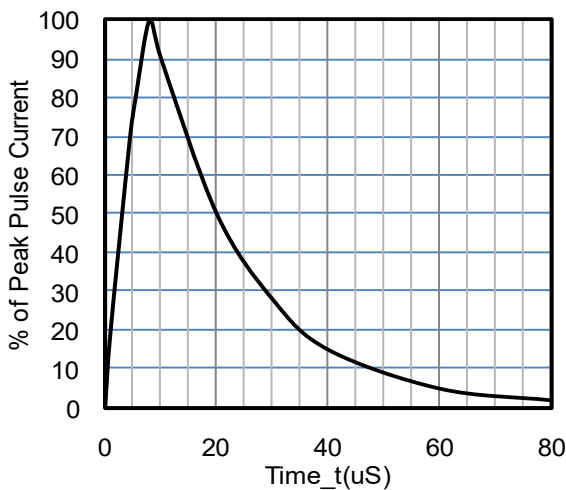

**8 X 20  $\mu\text{s}$  Pulse Waveform**

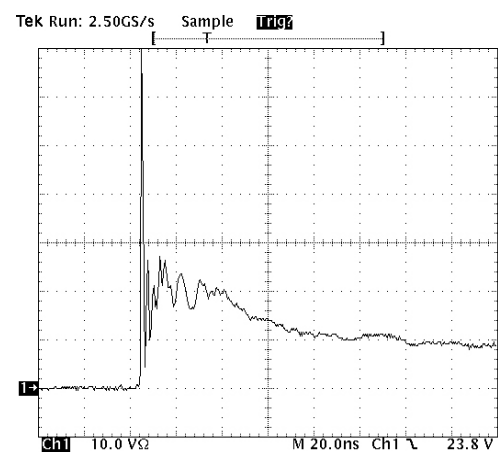

Note: Data is taken with a 10x attenuator

**ESD Clamping Voltage**

**8 kV Contact per IEC61000-4-2**

## Typical Application

The SRV05-4W is designed to protect four data lines from transient overvoltages by clamping them to fixed reference. When the voltage on the protected line exceeds the reference voltage (plus diode VF) the steering diodes are forward biased, conducting the transient current away from the sensitive circuitry. Data lines are connected at pins 1, 3, 4 and 6. The negative reference (REF1) is connected at pin 2. This pin should be connected directly to a ground plane on the board for best results. The path length is kept as short as possible to minimize parasitic inductance. The positive reference (REF2) is connected at pin 5.

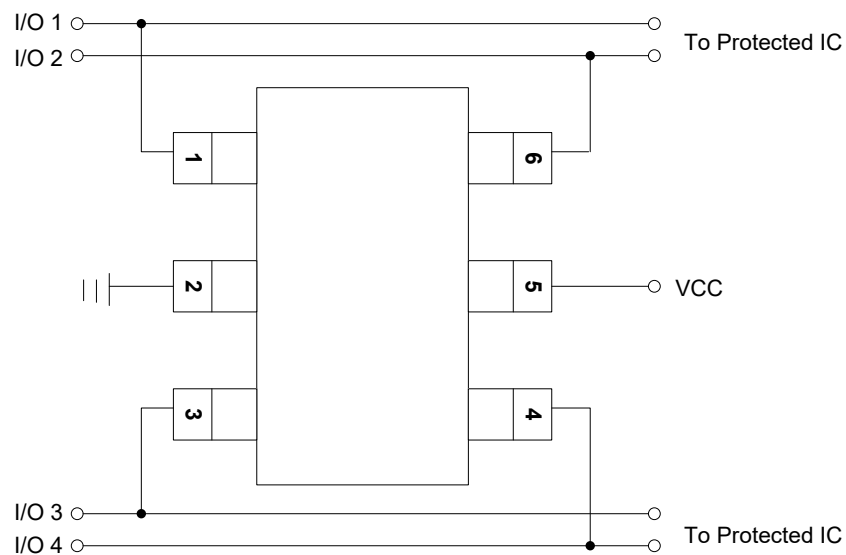

## SRV05-4W on Video Interface Application

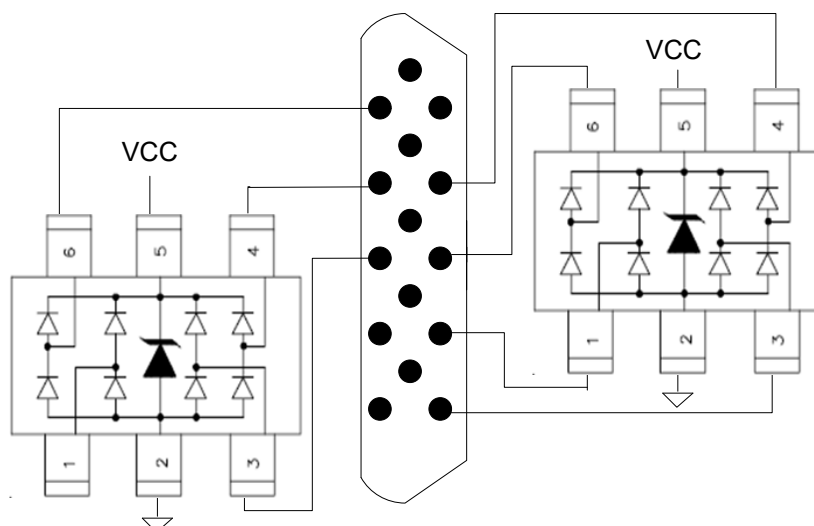

## SRV05-4W on USB Port Application

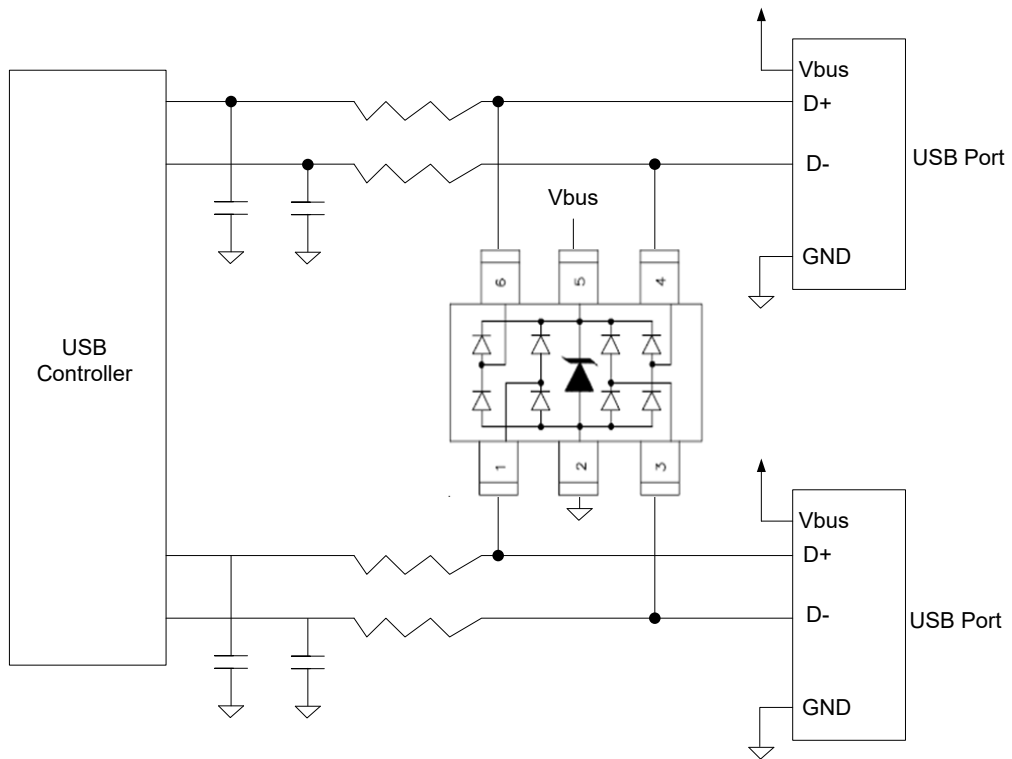

## SRV05-4W on SIM Port Application

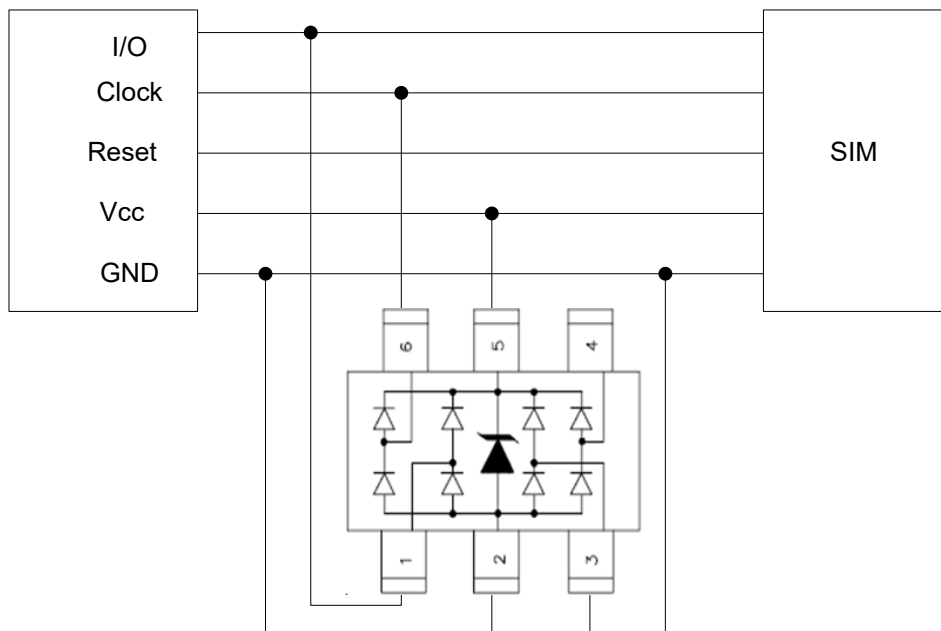

## SRV05-4W on Digital Visual Interface (DVI) Application

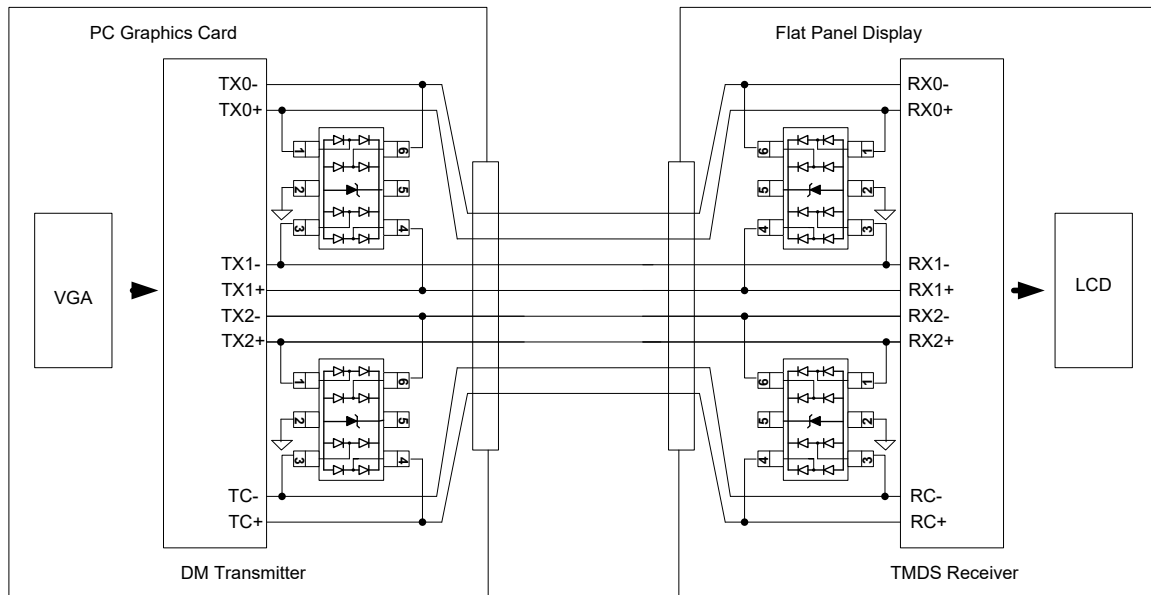

## SRV05-4W on Ethernet 10/100 (Differential mode) Application

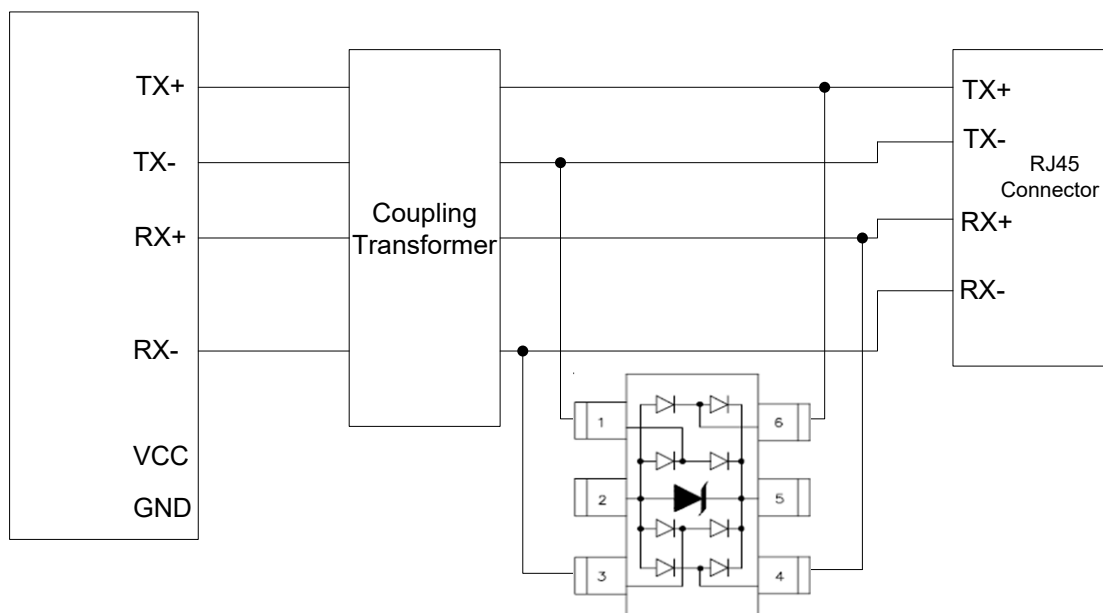

## SRV05-4W on T1/E1 Interface Application

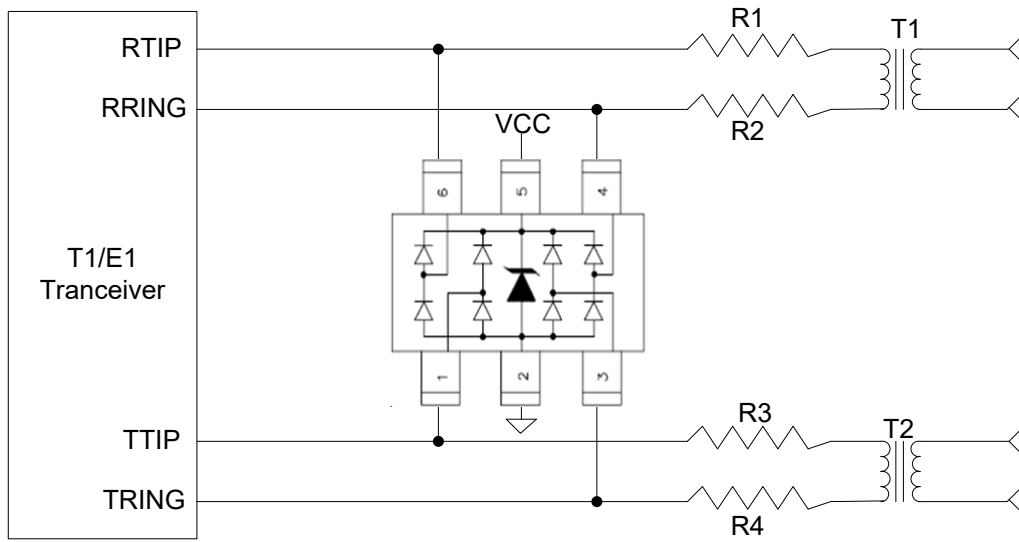

## SOT-26 Package Outline & Dimensions

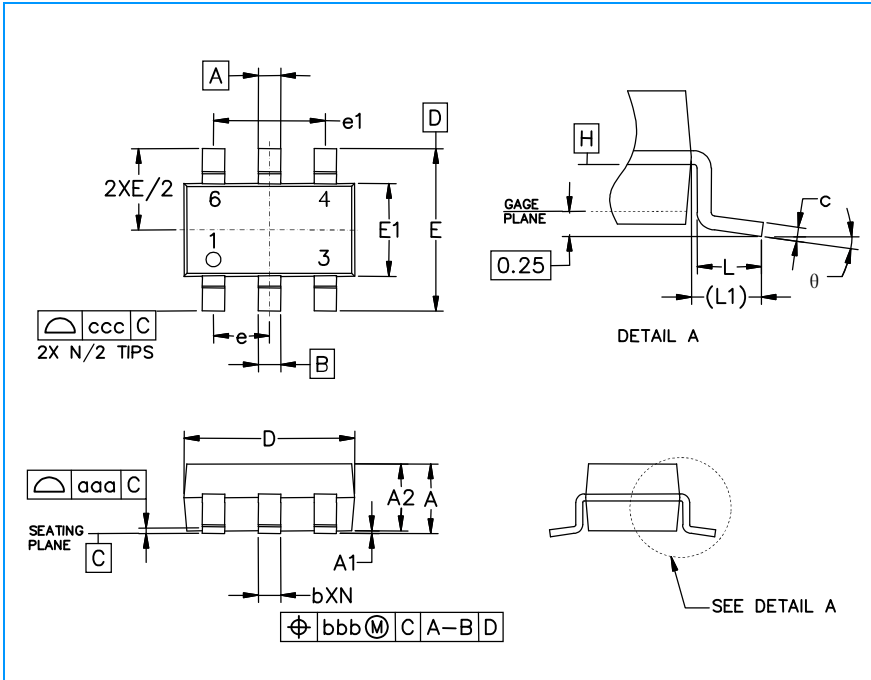

Symbol	Inches			Millimeters		
	Min.	Nom.	Max.	Min.	Nom.	Max.
A	0.035	-	0.057	0.90	-	1.45
A1	0.000	-	0.006	0.00	-	0.15
A2	0.035	0.045	0.051	0.90	1.15	1.30
b	0.010	-	0.020	0.25	-	0.50
c	0.003	-	0.009	0.08	-	0.22
D	0.110	0.114	0.122	2.80	2.90	3.10
E1	0.060	0.063	0.069	1.50	1.60	1.75
E	0.110 BSC			2.80 BSC		
e	0.037 BSC			0.95 BSC		
e1	0.075 BSC			1.90 BSC		
L	0.012	0.018	0.024	0.30	0.45	0.60
L1	(0.024)			(0.60)		
θ	0°	-	10°	0°	-	10°
aaa	0.004			0.10		
bbb	0.008			0.20		
ccc	0.008			0.20		

### Soldering Footprint

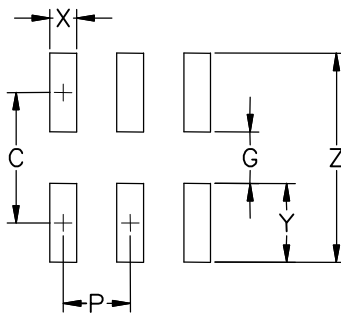

Symbol	Inches	Millimeters
C	(0.098)	(2.50)
G	0.055	1.40
P	0.037	0.95
X	0.024	0.60
Y	0.043	1.10
Z	0.141	3.60