



ST52T400/T440/E440/T441

8-BIT INTELLIGENT CONTROLLER UNIT (ICU) Timer/PWM, Analog Comparator, Triac/PWM Timer, WDG

PRELIMINARY DATASHEET

Memories

- Up to 8 Kbytes EPROM/OTP
- 128/256 bytes of RAM
- Readout Protection

Core

- Register File Based Architecture
- 55 instructions
- Hardware multiplication and division
- Decision Processor for the implementation of Fuzzy Logic algorithms

Clock and Power Supply

- Up to 20 MHz clock frequency.
- On-chip Power On Reset (POR) and Brown Out Detector (BOD)
- Power Saving features

Interrupts

- 6 interrupt vectors
- Top Level External Interrupt (INT)

I/O Ports

- 13 or 21 I/O PINs configurable in Input and Output mode
- High current sink/source in all pins. Triac Driver output can supply 50 mA

Peripherals

- Programmable 8-bit Timer/PWMs with internal 16-bit Prescaler featuring:
 - PWM output
 - Input capture
 - Output compare
 - Pulse generator mode
- Watchdog timer

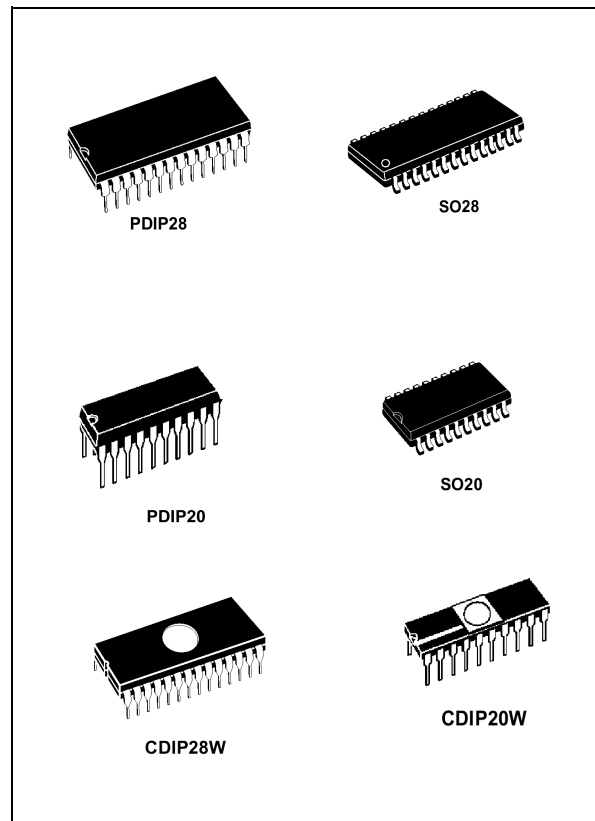

- 6-channels Analog Comparator with 16-bit Timer (not available in ST52T400)
- Triac/PWM Driver Timer with zero crossing detector and high current capability for:
 - PWM mode
 - Burst Mode
 - Phase Angle Partialization mode

Development tools

- High level Software tools
- Emulator
- Low cost Programmer
- Gang Programmer

ST52T400/T440/E440/T441

ST52T400/T440/E440/T441 Type List

ST52 Device	NVM (bytes)	RAM (bytes)	TIMER/ PWM	Analog Comparator	Triac Driver/ PWM	WDT	POR, BOD	Pull up	I/Os	Package
ST52T400Fmpy	1/2/4/8K	128/256	1	No	1	Yes	Yes	Yes	13	SO20, PDIP20
ST52T400Gmpy	1/2/4/8K	128/256							21	SO28, PDIP28
ST52T440Fmpy	1/2/4/8K	128/256	1	4 ch	1	Yes	Yes		13	SO20, PDIP20
ST52T440Gmpy	1/2/4/8K	128/256		21					SO28, PDIP28	
ST52E440F3D6	8K	256		13					CDIP20W	
ST52E440G3D6	8K	256		21					CDIP28W	
ST52T441Fmpy	1/2/4/8K	128/256	1	4 ch	1	Yes	Yes	No	13	SO20, PDIP20
ST52T441Gmpy	1/2/4/8K	128/256		21					SO28, PDIP28	
ST52E441F3D6	8K	256		13					CDIP20W	
ST52E441G3D6	8K	256		21					CDIP28W	

Note: devices with 1-2K NVM have 128 RAM; devices with 4-8K NVM have 256 RAM

COMMON FEATURES	ST52T400	ST52x440/ST52x441
Temperature Range	-40 to + 85 °C	-40 to + 85 °C
Operating Supply	2.7 to 5.5 V	4.5 to 5.5 V
CPU Frequency	Up to 20 MHz	Up to 20 MHz

Legend:

Sales code:	ST52tnnncmpy
Memory type (t):	F=FLASH, T=OTP, E=EPROM
Subfamily (nnn):	400, 410, 420, 430, 440, 441
Pin Count (c):	Y=16 pins, F=20 pins, G=28 pins, K=32/34 pins, J=42/44 pins
Memory Size (m):	0=1 Kb, 1=2 Kb, 2=4 Kb, 3=8 Kb
Packages (p):	B=PDIP, D=CDIP, M=PSO, T=TQFP
Temperature (y):	0=+25, 1=0 +70, 3=-40 +125, 5=-10 +85, 6=-40 +85, 7=-40 +105

TABLE OF CONTENTS

1 GENERAL DESCRIPTION	7
1.1 Introduction	7
1.2 Operational Description	8
1.2.1 Memory Programming Phase	8
1.2.2 Working Mode	8
1.3 Pin Description	18
2 INTERNAL ARCHITECTURE	19
2.1 Control Unit and Data Processing Unit	19
2.1.1 Program Counter	19
2.1.2 Flags	21
2.2 Address Spaces	21
2.2.1 Ram and Stack	22
2.2.2 Input Registers Bench	22
2.2.3 Configuration Registers	23
2.2.4 Output Registers	23
2.3 Fuzzy Computation	25
2.3.1 Fuzzy Inference	25
2.3.2 Fuzzyfication Phase	25
2.3.3 Inference Phase	26
2.3.4 Defuzzyfication	26
2.3.5 Input Membership Function	27
2.3.6 Output Singleton	27
2.3.7 Fuzzy Rules	27
2.4 Arithmetic Logic Unit	30
2.4.1 Addressing Modes	30
2.4.2 Instruction Types	30
3 EPROM Programming	33
3.1 EPROM Programming Phase Procedure	34
3.1.1 EPROM Operation	35
3.1.2 EPROM Locking	35
3.1.3 EPROM Writing	35
3.1.4 EPROM Reading/Verify Margin Mode	35
3.1.5 Stand by Mode	36
3.1.6 ID code	36
3.2 Eprom Erasure	36
4 INTERRUPTS	37
4.1 Interrupt Operation	37
4.2 Global Interrupt Request Enabling	38
4.3 Interrupt Sources	38
4.4 Interrupt Maskability	38

4.5 Interrupt Priority	40
4.6 Interrupts and Low power mode	41
4.7 Interrupt RESET	41
5 CLOCK, RESET & POWER SAVING MODE.....	42
5.1 Clock System	42
5.2 Reset	43
5.2.1 External Reset	43
5.2.2 Reset Operation	43
5.2.3 Power-on Reset (POR).....	43
5.2.4 Brown-Out Detector (BOD).....	44
5.3 Power Saving Modes	44
5.3.1 Wait Mode.....	44
5.3.2 Halt Mode	44
6 I/O PORTS	46
6.1 Introduction	46
6.2 Input Mode	47
6.3 Output Mode	47
6.4 Alternate Functions	48
6.5 I/O Port Configuration Registers.....	48
7 ANALOG COMPARATOR (ST52x440/441).....	50
7.1 Analog Module Overview	50
7.2 Comparator Mode.....	50
7.3 A/D Converter Mode.....	50
7.3.1 Operating Modes	51
8 WATCHDOG TIMER.....	54
8.1 Functional Description	54
8.2 Register Description	55
9 PWM/TIMER	56
9.1 Timer Mode.....	56
9.2 PWM Mode	57
9.3 Timer Interrupt	59
10 TRIAC/PWM DRIVER	63
10.1 TRIAC/PWM Driver Setting.....	64
10.2 PWM Mode Settings.....	65
10.3 Burst Mode	66
10.4 Phase Angle Partialization Working Mode	68
11 ELECTRICAL CHARACTERISTICS	72
11.1 Parameter Conditions	72
11.1.1 Minimum and Maximum values	72
11.1.2 Typical values.....	72
11.1.3 Typical curves.....	72
11.1.4 Loading capacitor	72
11.1.5 Pin input voltage	72
11.2 Absolute Maximum Ratings	72

TABLE OF CONTENTS

11.3 Recommended Operating Condition	74
11.4 Supply Current Characteristics	75
11.5 Brown-Out Detector characteristics	76
11.6 Clock and Timing Characteristics	77
11.7 Memory Characteristics	78
11.8 ESD Pin Protection Strategy	79
11.8.1 Standard Pin Protection	79
11.9 Port Pin Characteristics	80
11.9.1 General Characteristics	80
11.10	82
11.11 Control Pin Characteristics	84
11.11.1 RESET pin	84
11.11.2 Power on reset	84
11.11.3 VPP pin	84
11.12 Analog Comparator Characteristics	85
11.13 Triac Driver Characteristics	85
ORDERING INFORMATION	92

1 GENERAL DESCRIPTION

1.1 Introduction

ST52x400/440/441 are 8-bit Intelligent Control Units (ICU) of the ST Five Family, which are able to perform both boolean and fuzzy algorithms in an efficient manner, in order to reach the best performances that the two methodologies allow.

ST52x400/440/441 is produced by STMicroelectronics using the reliable high performance CMOS process, including integrated-on-chip peripherals that allow maximization of system reliability, decreasing system costs and minimizing the number of external components.

The flexible I/O configuration of ST52x400/440/441 allows for an interface with a wide range of external devices, like D/A converters or power control devices.

ST52x400/440/441 pins are configurable, allowing the user to set the input or output signals on each single pin.

A hardware multiplier (8 bit by 8 bit with 16 bit result) and divider (16 bit over 8 bit with 8 bit result and 8 bit remainder) is available to implement complex functions by using a single instruction, optimizing program memory utilization and computational speed.

Fuzzy Logic dedicated structures in ST52x400/440/441 ICU's can be exploited to model complex systems

with high accuracy in a useful and easy way. Fuzzy Expert Systems for overall system management and fuzzy Real time Controls can be designed to increase performances at highly competitive costs.

The linguistic approach characterizing Fuzzy Logic is based on a set of IF-THEN rules, which describe the control behavior, as well as on Membership Functions, which are associated to input and output variables.

Up to 334 Membership Functions, with triangular and trapezoidal shapes, or singleton values are available to describe fuzzy variables.

The TIMER/PWM peripheral allows the management of power devices and timing signals, implementing different operating modes and high frequency PWM (Pulse With Modulation) controls. Input Capture and Output Compare functions are available on the TIMER.

The programmable Timer has a 16 bit Internal Prescaler and an 8 bit Counter. It can use internal

or external START/STOP signals and clock.

An internal programmable WATCHDOG is available to avoid loop errors and to reset the ICU.

An Analog Comparator with a 6 channel multiplexer is available on ST52x440/441 family devices. This analog peripheral allows easy implementation of a high resolution A/D conversion. By using only an external capacitor this peripheral may be configured in order to achieve up to 12 bit A/D converter resolution. It includes a 2.5 V band-gap reference for A/D conversion calibration, which can be used externally for signal conditioning.

An on-chip TRIAC driver peripheral allows the direct management of power devices, implementing two different operating modes: Burst Mode (i.e. Thermal Applications), Phase Angle Partialization (i.e. Motors Control by Triacs). The TRIAC Driver also generates a PWM signal.

The ST52x400/440/441 family also includes an on-chip Power-on-Reset (POR), which provides an internal chip reset during power up situation and a Brown-Out Detector (BOD), which resets the ICU if the voltage source V_{DD} dips below a minimum value.

In order to optimize energy consumption, two different power saving modes are available: Wait mode and Halt mode.

Program Memory (EPROM/OTP) addressing capability addresses up to 8 Kbytes of memory locations to store both program instructions and permanent data.

EPROM can be locked by the user to prevent external undesired operations.

Operations may be performed on data stored in RAM, allowing the direct combination of new input and feedback data. All bytes of RAM are used like Register File.

OTP (One Time Programmable) version devices are fully compatible with the EPROM windowed version, which may be used for prototyping and pre-production phases of development.

A powerful development environment consisting of a board and software tools allows an easy configuration and use of ST52x400/440/441.

The VISUAL FIVE™ software tool allows development of projects through a user-friendly graphical interface and optimization of generated code.

1.2 Operational Description

ST52x400/440/441 ICU can work in two modes:

- Memory Programming Phase

- Working Phase

according to RESET and Vpp signals levels (see pins description).

Note: When RESET=0 it is advisable not to use the sequence “101010” to port PA (7 : 2).

Table 1.1 Control Signals Setting

Control Signal	Pro-gramming	Reset	Working
RESET	0	0	1
Vpp	5V /12V	0	0

1.2.1 Memory Programming Phase.

The ST52x400/440/441 memory is loaded in the Memory Programming Phase. All fuzzy and standard instructions are written inside the memory.

This phase starts by setting the control signals as illustrated in (see Table 1.1).

When this phase starts, the ST52x400/440/441 core is set to RESET status; then 12V are applied to the Vpp pin in order to start EPROM programming. A signal applied to PB1 is used to increment the memory address; the data is supplied to PORT A (see EPROM programming for further details).

1.2.2 Working Mode.

The processor starts the working phase following the instructions, which have been previously loaded in the memory.

ST52x400/440/441's internal structure includes a computational block, CONTROL UNIT (CU)/DATA PROCESSING UNIT (DPU), which allows processing of boolean functions and fuzzy algorithms.

The CU/DPU can manage up to 334 different Membership Functions for the fuzzy rules antecedent part. The rule consequents are “crisp” values (real numbers). The maximum number of rules that can be defined is limited by the dimensions of the implemented standard algorithm.

EPROM is then shared between fuzzy and standard algorithms. The Membership Function data is stored inside the first 1024 memory locations. The Fuzzy rules are parts of the program instructions.

The Control Unit (CU) reads the information and the status deriving from the peripherals.

Arithmetic calculus can be performed on these values by using the internal CU and the 128/256 bytes of RAM, which supports all computations. The peripheral input can be fuzzy and/or arithmetic output, or the values contained in Data RAM and EPROM locations.

Figure 1.1 ST52x400/440/441 Block Diagram

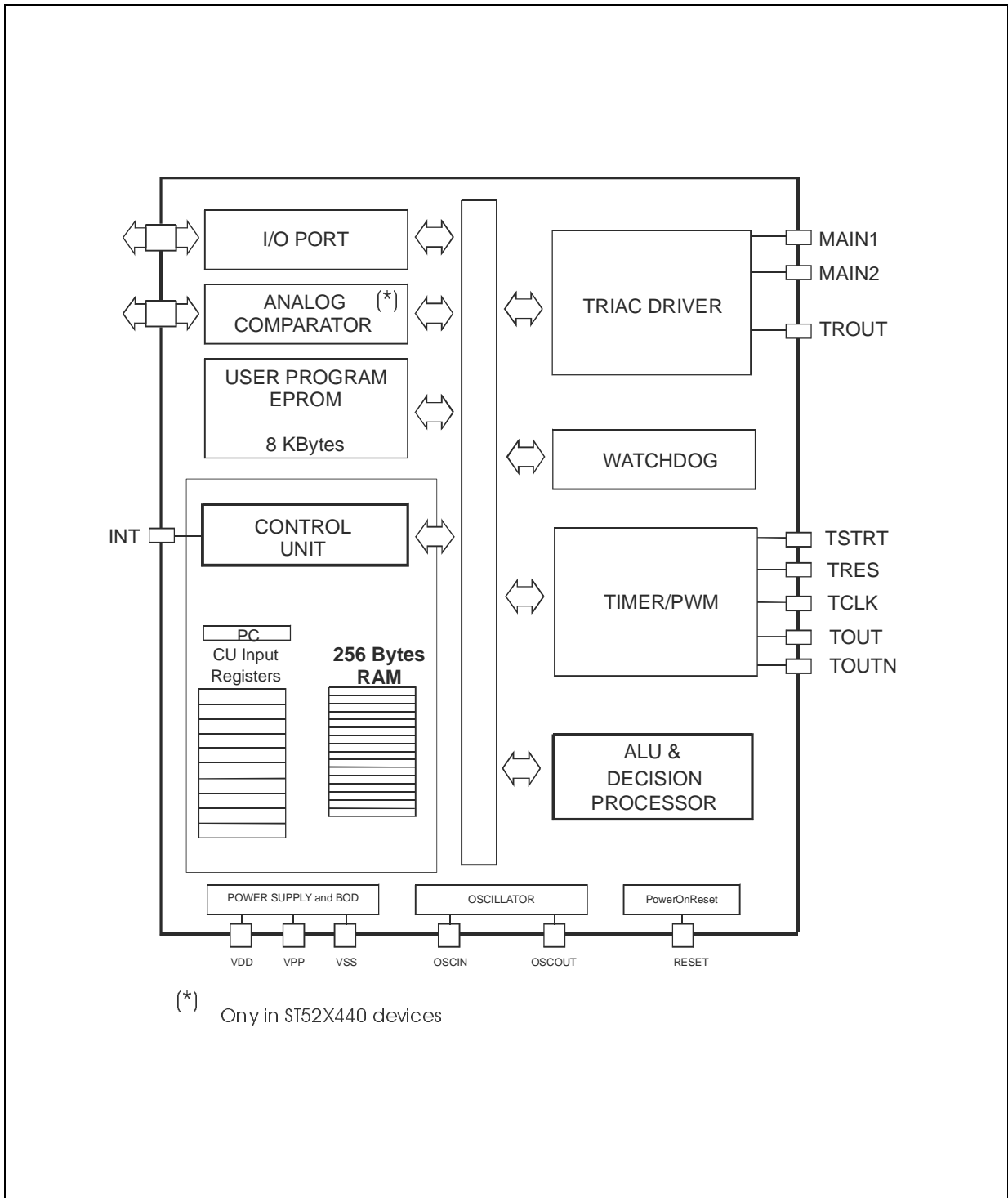

Figure 1.2 ST52x400 SO28 Pin Configuration

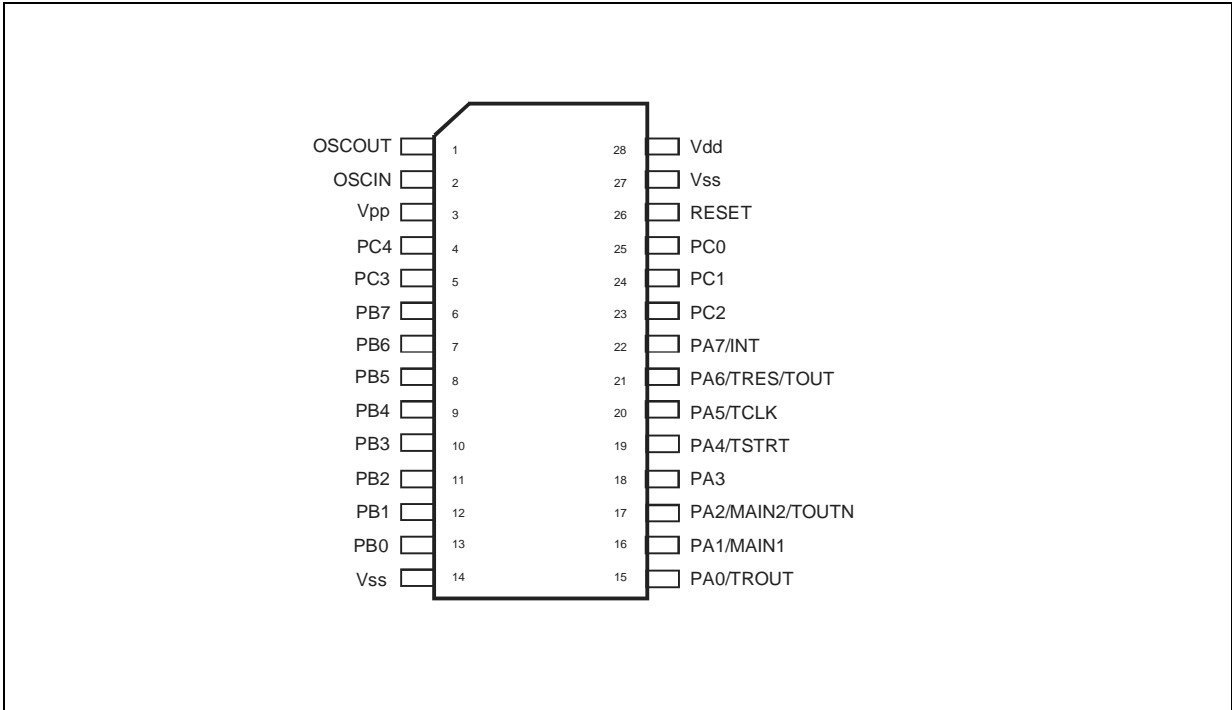

Figure 1.3 ST52x400 PDIP28 Pin Configuration

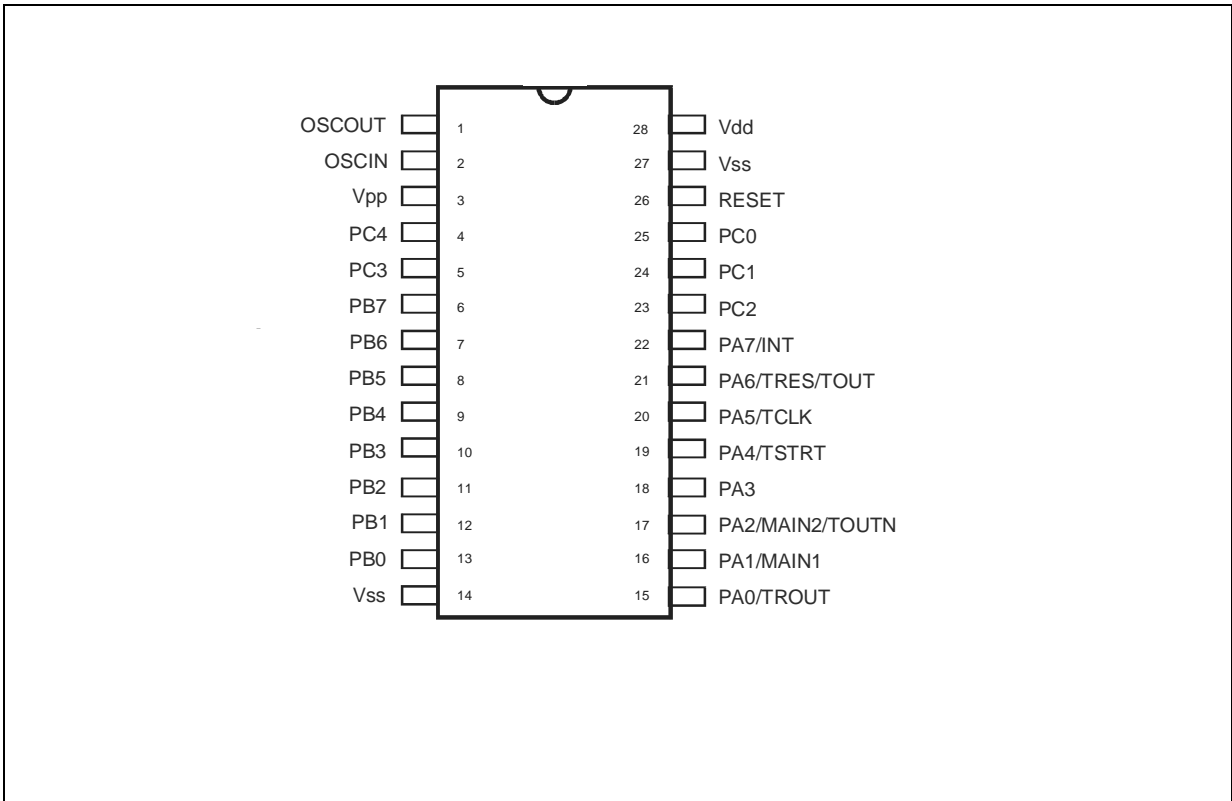

Figure 1.4 ST52x400 SO20 Pin Configuration

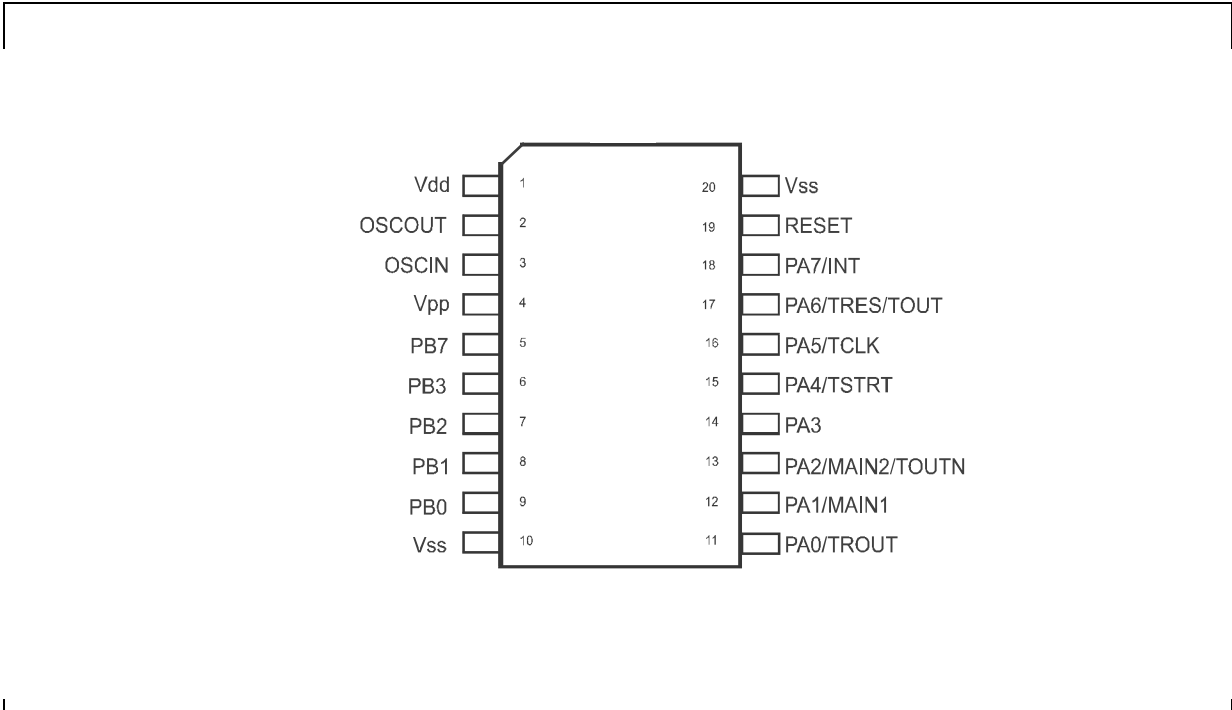

Figure 1.5 ST52x400 PDIP20 Pin Configuration

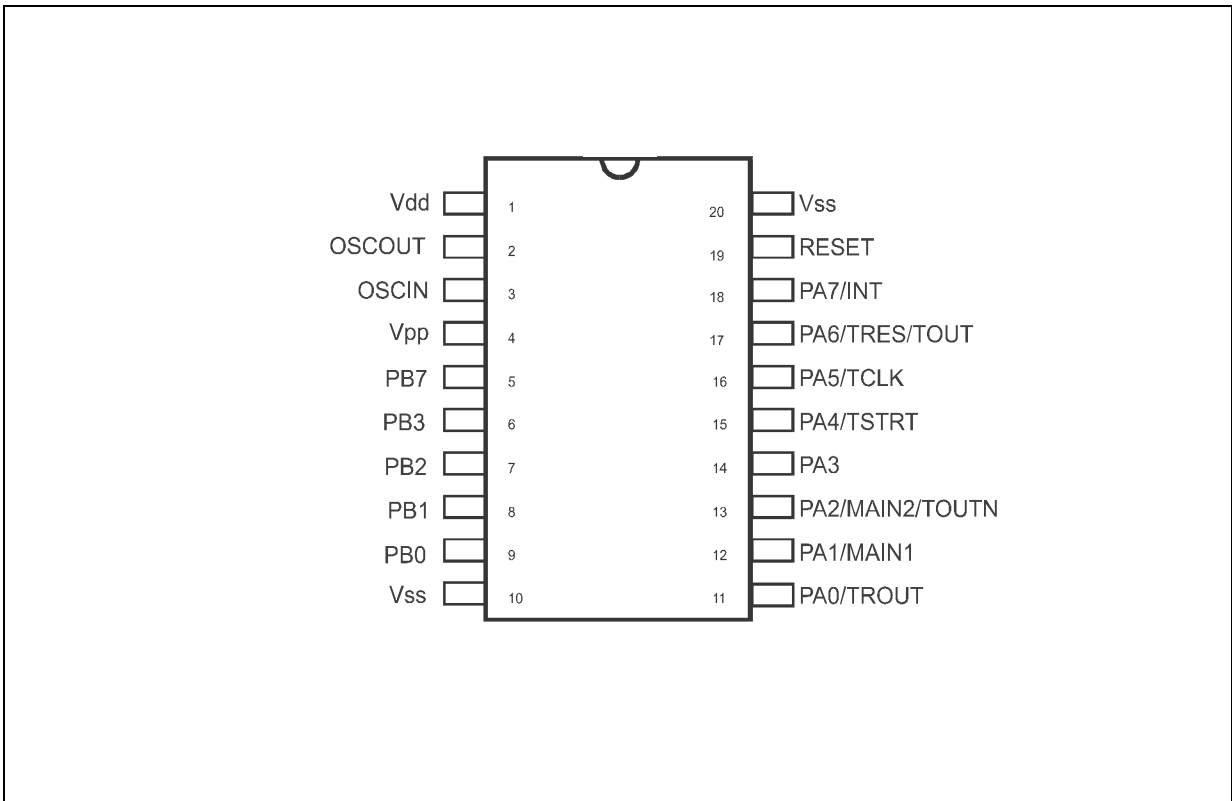

Figure 1.6 ST52x440/441 SO28 Pin Configuration

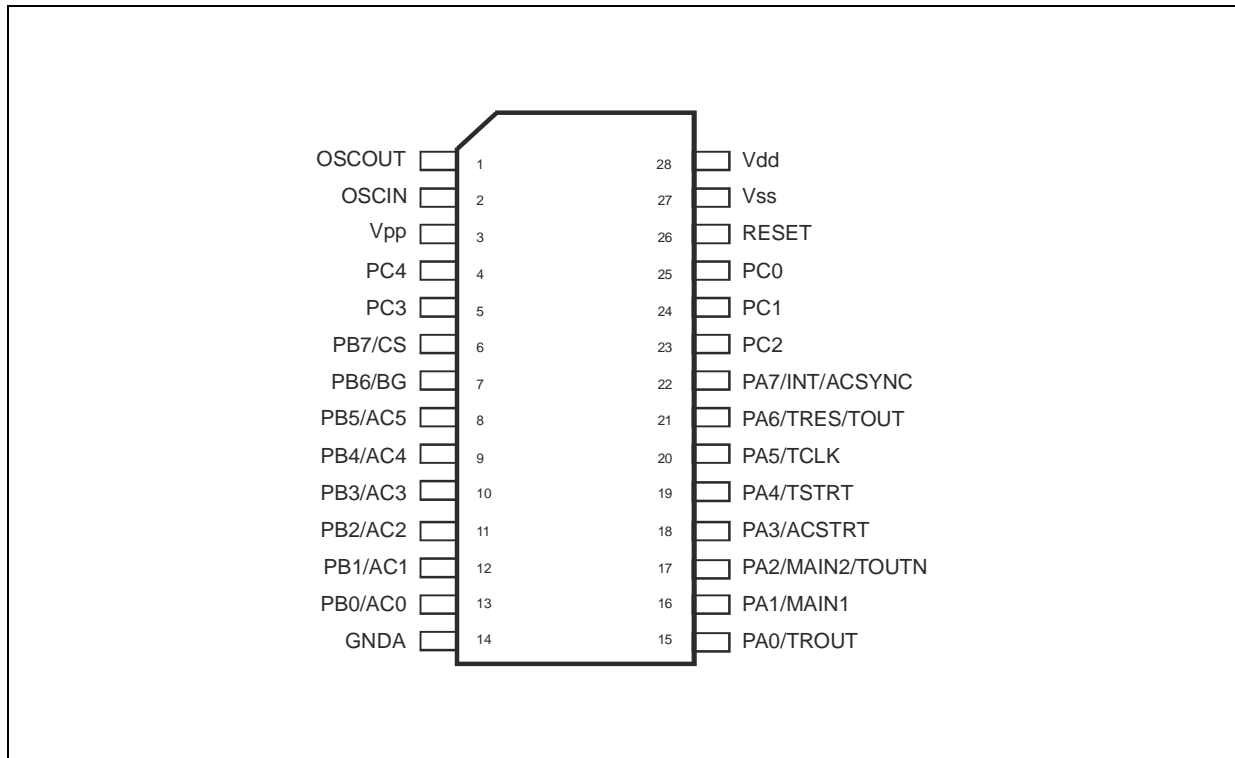

Figure 1.7 ST52x440/441 PDIP28 Pin Configuration

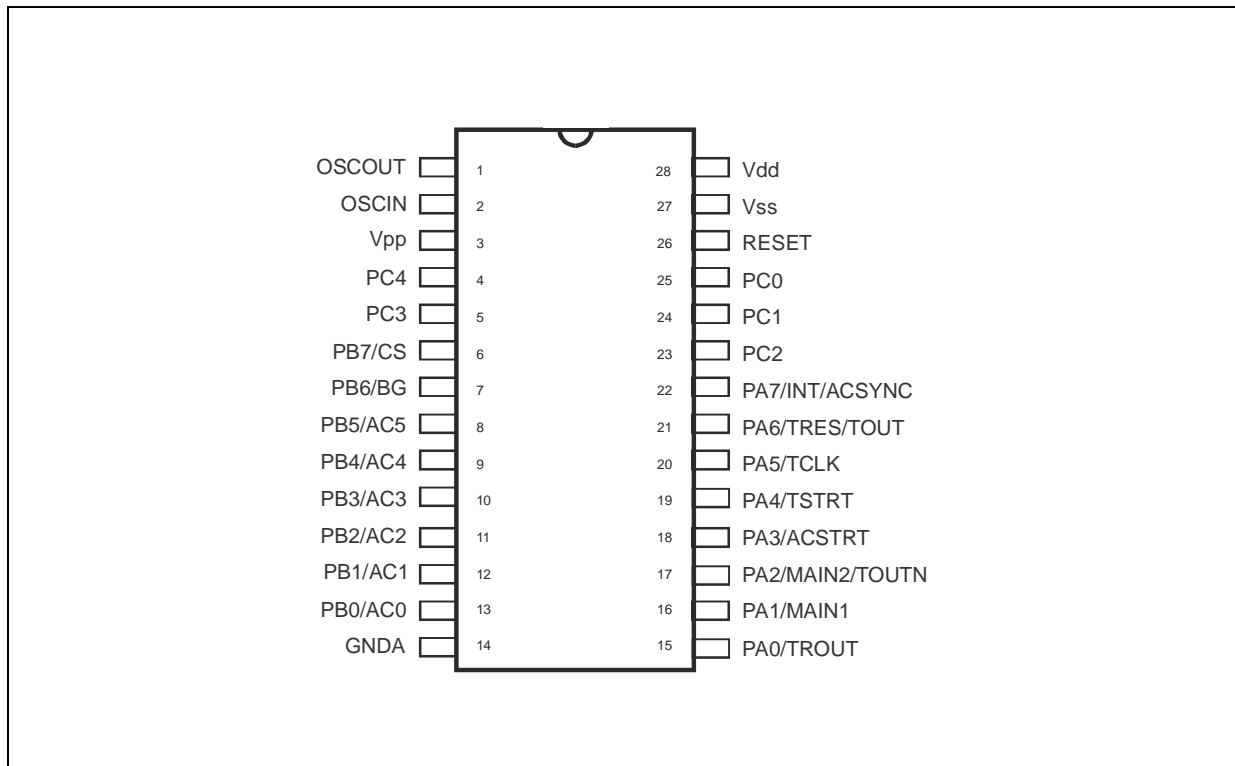

Figure 1.8 ST52x440/441 SO20 Pin Configuration

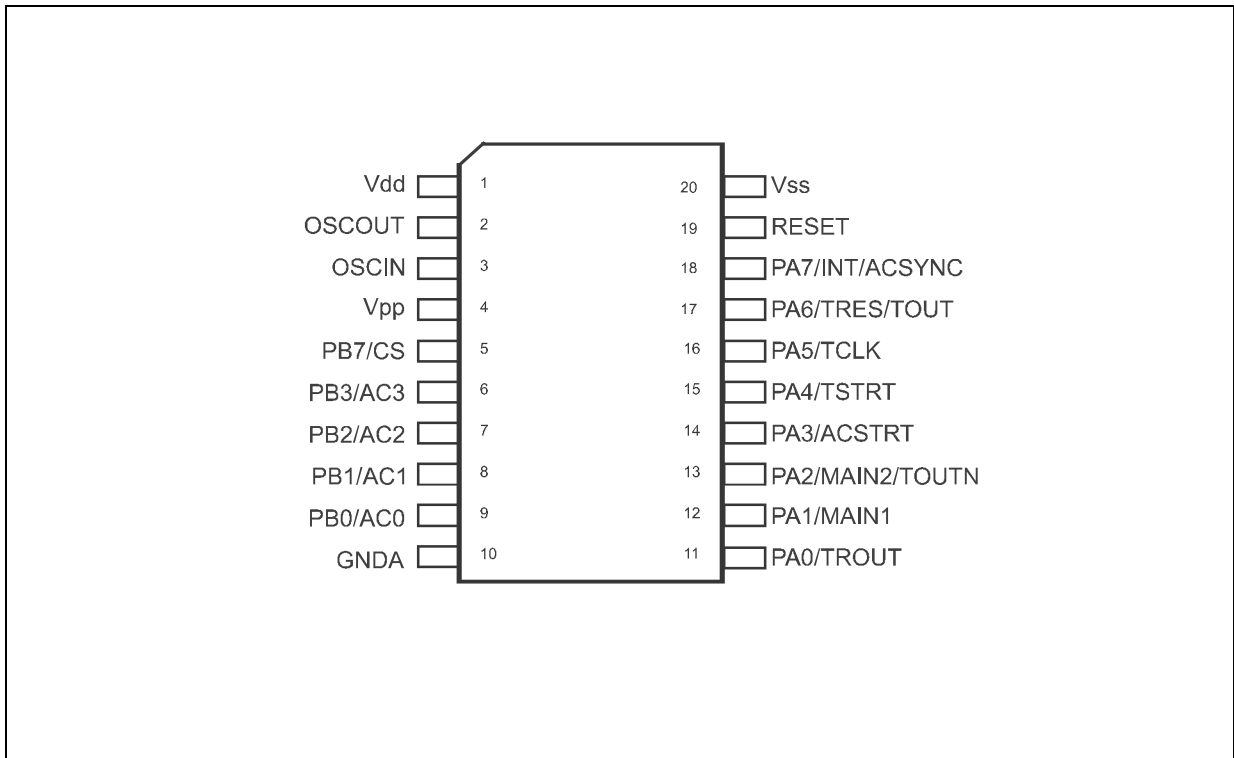

Figure 1.9 ST52x440/441 PDIP20 Pin Configuration

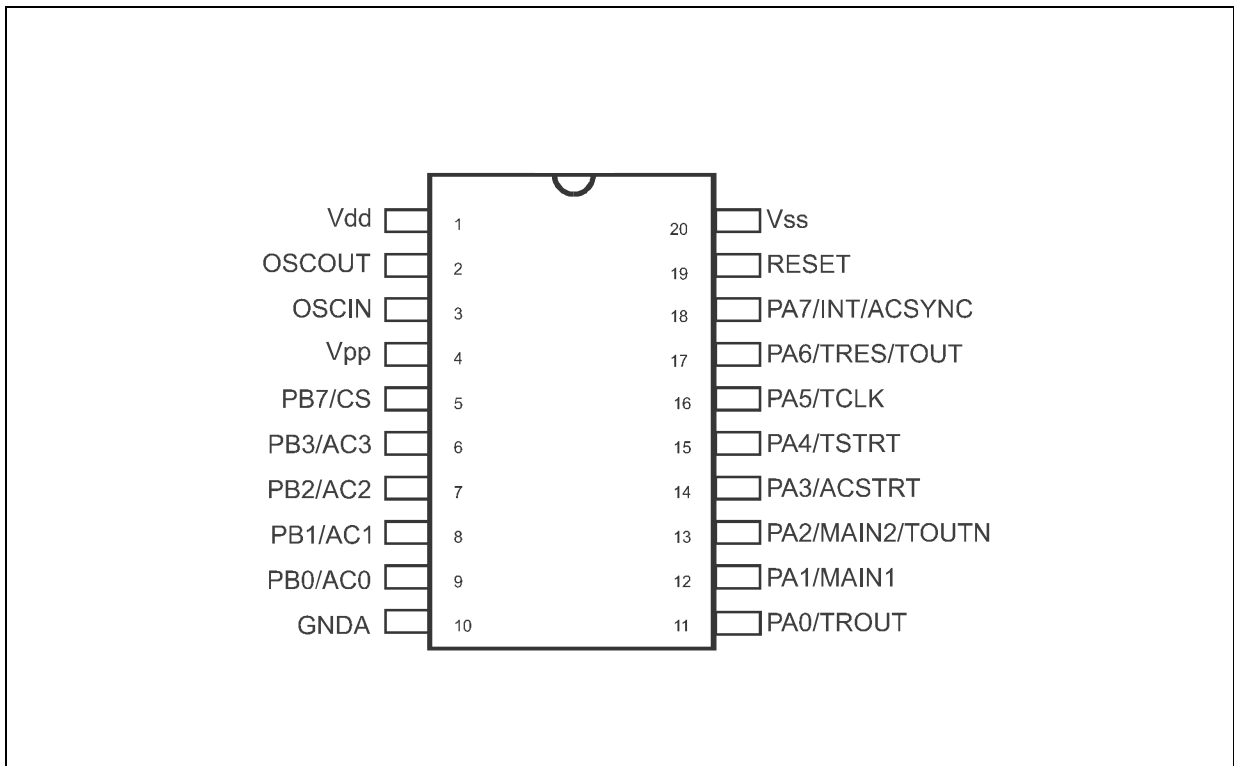

Table 1.2 SO28 and DIP28 Pin Configuration - ST52x400

PIN SO28/DIP28	NAME	Programming Phase	Working Phase
1	OSCOOUT		Oscillator Output
2	OSCIN		Oscillator Input
3	V _{pp}	EPROM Programming Power supply (12V±5%)	EPROM V _{DD} or V _{ss}
4	PC4		Digital I/O
5	PC3		Digital I/O
6	PB7	PHASE signal (PHASE)	Digital I/O
7	PB6		Digital I/O
8	PB5		Digital I/O
9	PB4		Digital I/O
10	PB3	Configuration INCREMENT (INC_CONF)	Digital I/O
11	PB2	Configuration RESET (RST_CONF)	Digital I/O
12	PB1	Address INCREMENT (INC_ADD)	Digital I/O
13	PB0	Address Reset (RST_ADD)	Digital I/O
14	V _{ss}		This pin must be tied to Digital Ground
15	PA0/TROUT	I/O EPROM Data	Digital I/O - TRIAC Driver Output
16	PA1/MAIN1	I/O EPROM Data	Digital I/O Zero Crossing Detection pin 1
17	PA2/MAIN2/ TOUTN	I/O EPROM Data	Digital I/O Zero Crossing Detection pin 2 Complementary Timer Output
18	PA3	I/O EPROM Data	Digital I/O
19	PA4/TSTRT	I/O EPROM Data	Digital I/O - Timer external start
20	PA5/TCLK	I/O EPROM Data	Digital I/O - Timer external clock
21	PA6/TRES/TOUT	I/O EPROM Data	Digital I/O Timer external reset - Timer output
22	PA7/INT	I/O EPROM Data	Digital I/O External Interrupt
23	PC2		Digital I/O
24	PC1		Digital I/O
25	PC0		Digital I/O
26	RESET	General Reset	General Reset
27	V _{ss}	Digital Ground	Digital Ground
28	V _{DD}	Digital Power Supply	Digital Power Supply

Table 1.3 SO20 and DIP20 Pin Configuration - ST52x400

PIN SO20/DIP20	NAME	Programming Phase	Working Phase
1	V _{DD}	Digital Power Supply	Digital Power Supply
2	OSCOUT		Oscillator Output
3	OSCIN		Oscillator Input
4	V _{pp}	EPROM Programming Power supply (12V±5%)	EPROM V _{DD} or V _{SS}
5	PB7	PHASE signal (PHASE)	Digital I/O
6	PB3	Configuration INCREMENT (INC_CONF)	Digital I/O
7	PB2	Configuration RESET (RST_CONF)	Digital I/O
8	PB1	Address INCREMENT (INC_ADD)	Digital I/O
9	PB0	Address Reset (RST_ADD)	Digital I/O
10	V _{SS}		This pin must be tied to Digital Ground
11	PA0/TROUT	I/O EPROM Data	Digital I/O - TRIAC Driver Output
12	PA1/MAIN1	I/O EPROM Data	Digital I/O Zero Crossing Detection pin 1
13	PA2/MAIN2/ TOUTN	I/O EPROM Data	Digital I/O Zero Crossing Detection pin 2 Complementary Timer Output
14	PA3	I/O EPROM Data	Digital I/O
15	PA4/TSTRT	I/O EPROM Data	Digital I/O - Timer external start
16	PA5/TCLK	I/O EPROM Data	Digital I/O - Timer external clock
17	PA6/TRES/TOUT	I/O EPROM Data	Digital I/O Timer external reset - Timer output
18	PA7/INT	I/O EPROM Data	Digital I/O External Interrupt
19	RESET	General Reset	General Reset
20	V _{SS}	Digital Ground	Digital Ground

Table 1.4 SO28 and DIP28 Pin Configuration - ST52x440/441

PIN SO28/DIP28	NAME	Programming Phase	Working Phase
1	OSCOUT		Oscillator Output
2	OSCIN		Oscillator Input
3	V _{pp}	EPROM Programming Power supply (12V±5%)	EPROM V _{DD} or V _{SS}
4	PC4		Digital I/O
5	PC3		Digital I/O
6	PB7/CS	PHASE signal (PHASE)	Digital I/O - Capacitor connection
7	PB6/BG		Digital I/O - Bandgap reference
8	PB5/AC5		Digital I/O Analog Comparator Channel 5
9	PB4/AC4		Digital I/O Analog Comparator Channel 4
10	PB3/AC3	Configuration INCREMENT (INC_CONF)	Digital I/O Analog Comparator Channel 3
11	PB2/AC2	Configuration RESET (RST_CONF)	Digital I/O Analog Comparator Channel 2
12	PB1/AC1	Address INCREMENT (INC_ADD)	Digital I/O Analog Comparator Channel 1
13	PB0/AC0	Address Reset (RST_ADD)	Digital I/O Analog Comparator Channel 0
14	GNDA	Analog Ground	Analog Ground
15	PA0/TROUT	I/O EPROM Data	Digital I/O - TRIAC Driver Output
16	PA1/MAIN1	I/O EPROM Data	Digital I/O Zero Crossing Detection pin 1
17	PA2/MAIN2/ TOUTN	I/O EPROM Data	Digital I/O Zero Crossing Detection pin 2
18	PA3/ACSTRT	I/O EPROM Data	Digital I/O Analog Comp. counter external start
19	PA4/TSTRT	I/O EPROM Data	Digital I/O - Timer external start
20	PA5/TCLK	I/O EPROM Data	Digital I/O - Timer external clock
21	PA6/TRES/TOUT	I/O EPROM Data	Digital I/O Timer external reset - Timer output
22	PA7/INT/ ACSYNC	I/O EPROM Data	Digital I/O - External Interrupt Analog Comparator counter ready
23	PC2		Digital I/O
24	PC1		Digital I/O
25	PC0		Digital I/O
26	RESET	General Reset	General Reset
27	V _{SS}	Digital Ground	Digital Ground
28	V _{DD}	Digital Power Supply	Digital Power Supply

Table 1.5 SO20 and DIP20 Pin Configuration - ST52x440/441

PIN SO20/DIP20	NAME	Programming Phase	Working Phase
1	V _{DD}	Digital Power Supply	Digital Power Supply
2	OSCOUT		Oscillator Output
3	OSCIN		Oscillator Input
4	V _{pp}	EPROM Programming Power supply (12V±5%)	EPROM V _{DD} or V _{SS}
5	PB7/CS	PHASE signal (PHASE)	Digital I/O - Capacitor connection
6	PB3/AC3	Configuration INCREMENT (INC_CONF)	Digital I/O Analog Comparator Channel 3
7	PB2/AC2	Configuration RESET (RST_CONF)	Digital I/O Analog Comparator Channel 2
8	PB1/AC1	Address INCREMENT (INC_ADD)	Digital I/O Analog Comparator Channel 1
9	PB0/AC0	Address Reset (RST_ADD)	Digital I/O Analog Comparator Channel 0
10	GNDA	Analog Ground	Analog Ground
11	PA0/TROUT	I/O EPROM Data	Digital I/O - TRIAC Driver Output
12	PA1/MAIN1	I/O EPROM Data	Digital I/O Zero Crossing Detection pin 1
13	PA2/MAIN2/ TOUTN	I/O EPROM Data	Digital I/O Zero Crossing Detection pin 2 Complementary Timer Output
14	PA3/ACSTRT	I/O EPROM Data	Digital I/O Analog Comp. counter external start
15	PA4/TSTRT	I/O EPROM Data	Digital I/O - Timer external start
16	PA5/TCLK	I/O EPROM Data	Digital I/O - Timer external clock
17	PA6/TRES/TOUT	I/O EPROM Data	Digital I/O Timer external reset - Timer output
18	PA7/INT/ ACSYNC	I/O EPROM Data	Digital I/O - External Interrupt Analog Comparator counter ready
19	RESET	General Reset	General Reset
20	V _{SS}	Digital Ground	Digital Ground

1.3 Pin Description

ST52x400/440/441 pins can be set in digital input mode, digital output mode or in Alternate Functions. The pin configuration is achieved by means of the configuration registers. The functions of the ST52x400/440/441 pins are described below:

V_{DD}. Main Power Supply Voltage ($5V \pm 10\%$).

V_{SS}. Digital circuit Ground. **All V_{SS} pins must be connected to ground** (see ST52T400 pin-out).

GNDA. Analog circuit ground of the Analog Comparator. Must be tied to V_{SS}.

V_{PP}. Main Power Supply for internal EPROM programming and MODE selector. During the Programming phase V_{PP} must be set at 12V. In the Working phase V_{PP} must be equal to V_{SS}.

OSCin and **OSCout**. These pins are internally connected to the on-chip oscillator circuit. A quartz crystal or a ceramic resonator can be connected between these two pins in order to allow the correct operations of ST52x400/440/441 with various stability/cost trade-offs. An external clock signal can be applied to OSCin: in this case OSCout must be grounded.

RESET. This signal is used to reset the ST52x400/440/441 and re-initialize the registers and control signals. It also allows the user to select the working mode of the device.

PA0-PA7, PB0-PB7, PC0-PC4. These lines are organized as I/O ports. Each pin can be configured as an input or output. During the Programming phase the ports are used for EPROM data read/write operations.

AC0-AC5(*). These pins are used to input the analog signals to the Analog Comparator. An analog multiplexer is available to switch these inputs to the Analog Comparator.

CS(*). This pin outputs the current generated in the Analog Comparator peripheral by a current generator, allowing charging of an external capacitor to obtain a voltage ramp for the A/D conversion.

ACSTRT, ACSYNC(*). These pins are used to synchronize the 16-bit counter of the Analog Comparator with an external ramp generator. The ACSTRT input is used to start the counter. The ACSYNC output is set when the counter is ready to start a new count.

BG(*). A Bandgap Reference value of 2.5V is available on this pin. It can be used for analog signal conditioning.

TOUT, TOUTN. These pins output the signal generated by the TIMER peripheral. The TOUTN signal is the complement of the TOUT one.

TRES, TSTRT, TCLK. These pins are related to the TIMER peripheral and are used for Input Capture and event counting. The TRES pin is used to set/reset the Timer; the TSTRT pin is used to start/stop the counter. The Timer can be driven by the internal clock or by an external signal connected to the TCLK pin.

TROUT, MAIN1, MAIN2. These pins are related to the TRIAC DRIVER peripheral. TROUT outputs the signal generated by the peripheral. In order to drive a TRIAC directly without the use of additional components, the TROUT pin can supply up to 50 mA (2V voltage drop). MAIN1 and MAIN2 pins are used to detect the zero crossing of the Power Line voltage.

(*) Not available in ST52x400 devices

2 INTERNAL ARCHITECTURE

ST52x400/440/441 is composed of the following blocks and peripherals:

- Control Unit (CU)
- Data Processing Unit (DPU)
- ALU
- Decision Processor (DP)
- EPROM
- 256 Byte RAM
- Clock Oscillator
- Analog Multiplexer and Analog Comparator
- 1 PWM / Timer
- 1 Triac/PWM Driver
- Digital I/O port

2.1 Control Unit and Data Processing Unit

The Control Unit (CU) formally includes five main blocks. Each block decodes a set of instructions, generating the appropriate control signals. The main parts of the CU are shown in Figure 2.1.

The five different parts of the CU manage Loading, Logic/Arithmetic, Jump, Control and Decision Processor (DP) instructions sets.

The block called "Collector" manages the signals deriving from the different parts of the CU then defines the signals for the Data Processing Unit (DPU) and for the different peripherals of the ICU. The block called "Arbiter" manages the different

parts of the CU in order to have only one part of the system activated during working mode.

The CU structure is highly flexible, designed with the objective of easily adapting the core of the microcontroller to market needs. New instructions sets or new peripherals can be easily included without changing the structure of the microcontroller, maintaining code compatibility.

The CU reads and decodes the instructions stored on the EPROM (Fetch). According to the instructions type, the Arbiter activates one of the main blocks of the CU. Afterwards, all the control signals for the DPU are generated.

A set of 55 different arithmetic, DP and logic instructions is available. The arithmetic instructions operate to all the RAM addresses without the need of using special registers.

The DPU receives, stores and sends the instructions coming from the EPROM, RAM or from the peripherals in order to execute them.

2.1.1 Program Counter.

The Program Counter (PC) is a 13-bit register that contains the address of the next memory location to be processed by the core. This memory location may be an opcode, an operand or an address of an operand.

Figure 2.1 CU Block Diagram

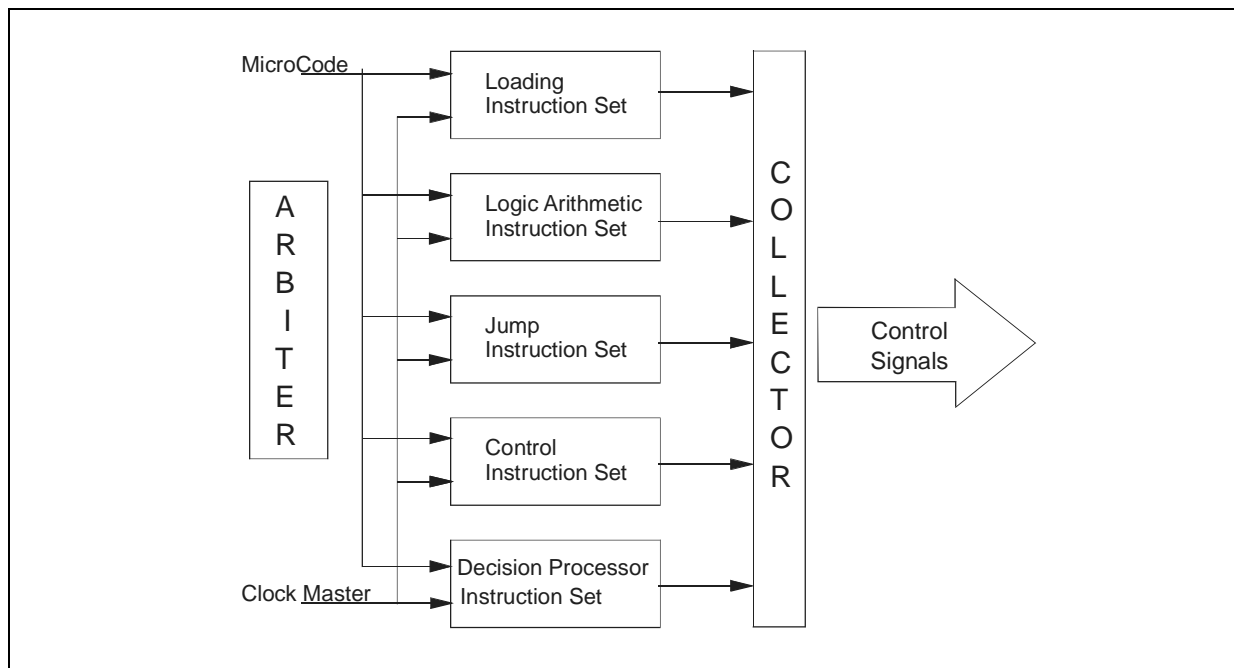

Figure 2.2 Data Processing Unit (DPU)

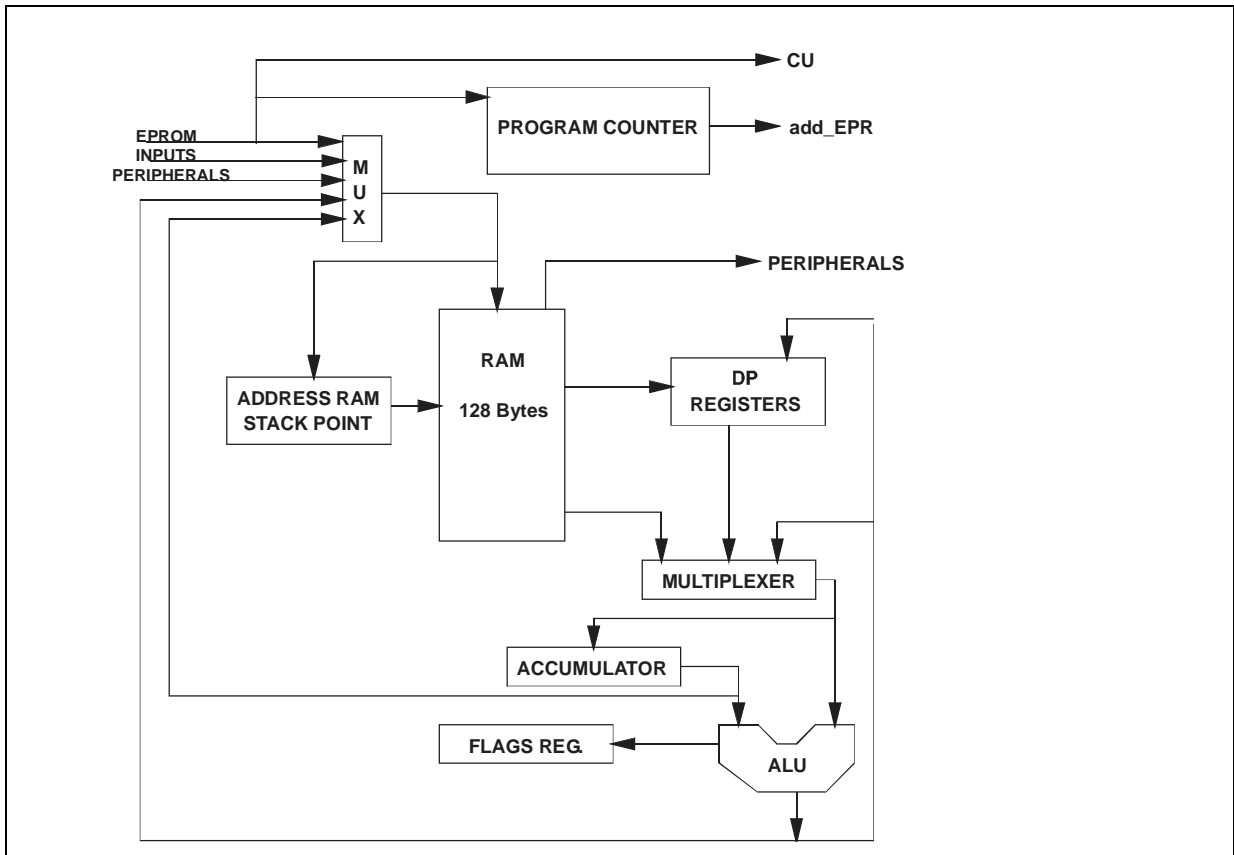
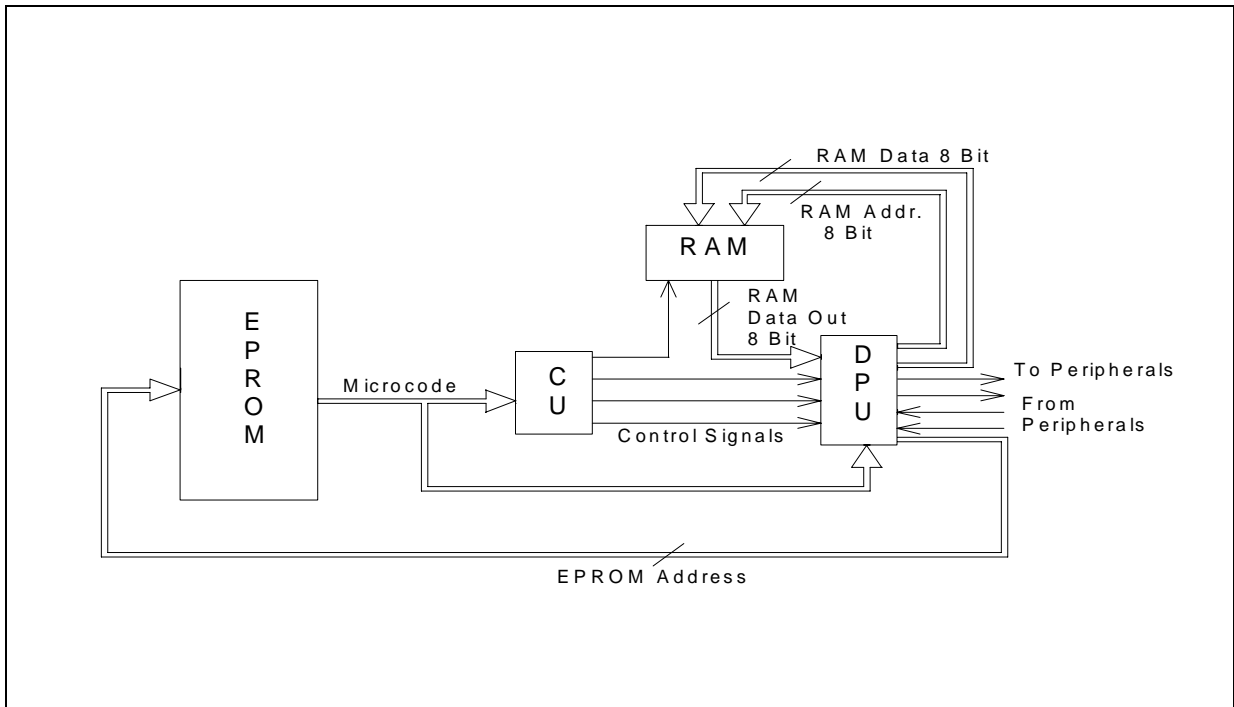

Figure 2.3 CU/DPU Block Diagram



The 13-bit length allows the direct addressing of 8192 bytes in the program space: jump and call instruction support the absolute addressing in all the memory.

After having read the current instruction address, the PC value is incremented. The result of this operation is shifted back into the PC.

The PC can be changed in the following ways:

- JP (Jump) instruction PC = Jump Address
- Interrupt PC = Interrupt Vector
- RETI instruction PC = Pop (stack)
- Reset PC = Reset Vector
- Normal Instruction PC = PC + 1

2.1.2 Flags.

The ST52x400/440/441 core includes different sets of flags that correspond to 2 different modes: normal mode and interrupt mode. Each set of flags consist of a CARRY flag (C), ZERO flag (Z) and SIGN flag (S). One set of flags (CN, ZN, SN) is used during normal operation and one is used during interrupt mode (CI, ZI, SI). Formally, the user has to manage only one set of flags: C, Z and S.

The ST52x400/440/441 core uses the flags that correspond to the actual mode: as soon as an interrupt is generated, the ST FIVE core uses the interrupt flags instead of the normal flags.

Each interrupt level has its own set of flags, which is saved in the Flag Stack during interrupt servic-

ing.

These flags are restored from the Flag Stack automatically when a RETI instruction is executed.

If the ICU was in the normal mode before an interrupt, after the RETI instruction is executed, the normal flags are restored.

Note: A CALL subroutine is a normal mode execution. For this reason a RET instruction, consequent to a CALL instruction, doesn't affect the normal mode set of flags.

Flags are not cleared during context switching and remain in the state they were located in at the end of the last interrupt routine switching.

The Carry flag is set when an overflow occurs during arithmetic operations, otherwise it is cleared.

The Sign flag is set when an underflow occurs during arithmetic operations, otherwise it is cleared.

2.2 Address Spaces

ST52x400/440/441 has four separate address spaces:

- RAM: 128 or 256 Bytes
- 20 Input Registers
- 6 Output Registers
- 21 Configuration Registers
- Program memory: up to 8K Bytes

The Program Memory will be described in further details in the EPROM section

Figure 2.4 Address Spaces Description

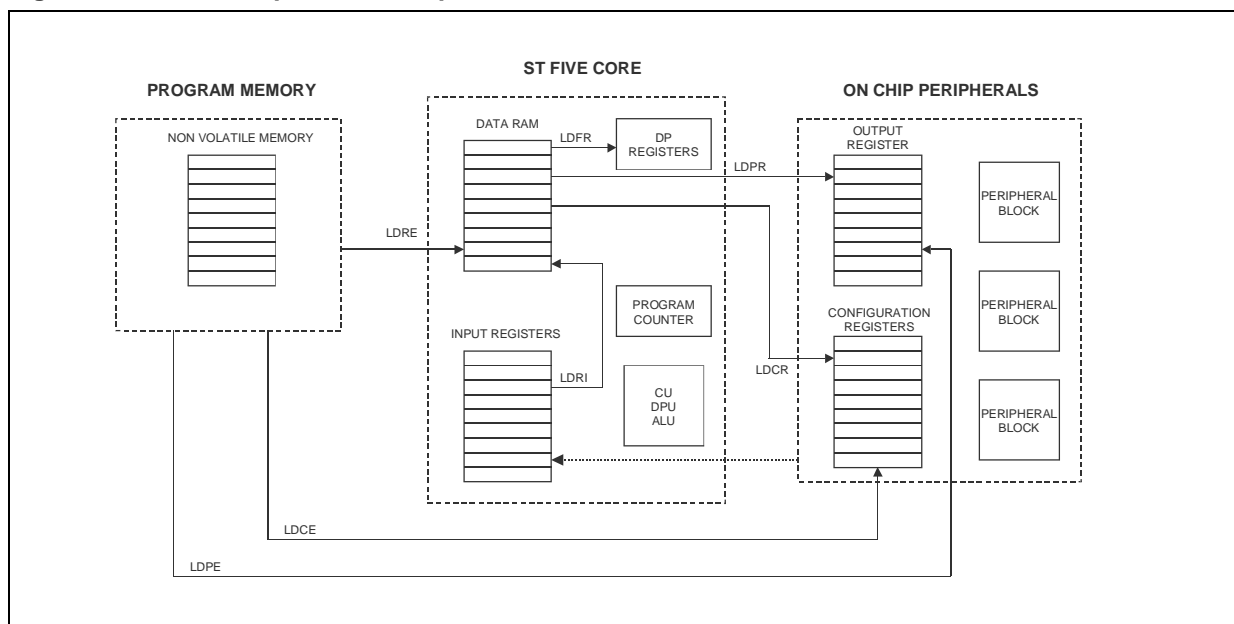

2.2.1 Ram and Stack.

RAM consists of 128 (G0/G1/F0/F1 types) or 256 (G2/G3/F2/F3 types) general purpose 8-bit registers.

All the registers in RAM can be specified by using a decimal address, e.g. 0 identifies the first register of RAM.

To read or write in the RAM registers, the LOAD instructions must be used (see Table 2.5).

When the instructions like Interrupt request or CALL are executed, a STACK is used to push the PC. The STACK is push directly in the RAM. For each level of stack 2 bytes of RAM are used. The values of this stack are stored from the last RAM register (address 255). The maximum level of stack must be less than 128. When a subroutine call or interrupt request occurs, the contents of each level is shifted into the next level while the content of the PC is shifted into the first level. When a subroutine or interrupt return occurs (RET or RETI instructions), the first level register is shifted back into the PC and the value of each level is popped back into the previous level. These operating modes are illustrated in Figure 2.5.

2.2.2 Input Registers Bench.

The Input Registers (IR) bench consists of 20 8-bit registers containing data deriving from the peripherals and parallel ports.

All the registers can be specified by using a decimal address, e.g. 0 identifies the first register of the IR.

The assembler instruction: *LDRI reg,inp_teg* loads the value in the *inp* IR to the register (RAM location) identified by the address *reg*.

The first input register is dedicated to store the value of the stack pointer. The next 12 registers of the IR are dedicated to the 6 (for ST52X440G/441G) or the 4 converted values (for ST52X440F/441F) in case of converted values coming from the Analog Comparator (in ST52x400 devices these registers are not used). Each of these values are stored on two bytes because of the resolution of the A/D conversion process. The last 7 registers contain data from the I/O ports and PWM/Timers. Table 2.1 summarizes the IR address and the relative peripheral. In order to simplify the concept a mnemonic name is assigned to the registers. The same name is used in VISUAL FIVE development tools.

Figure 2.5 Stack Operation

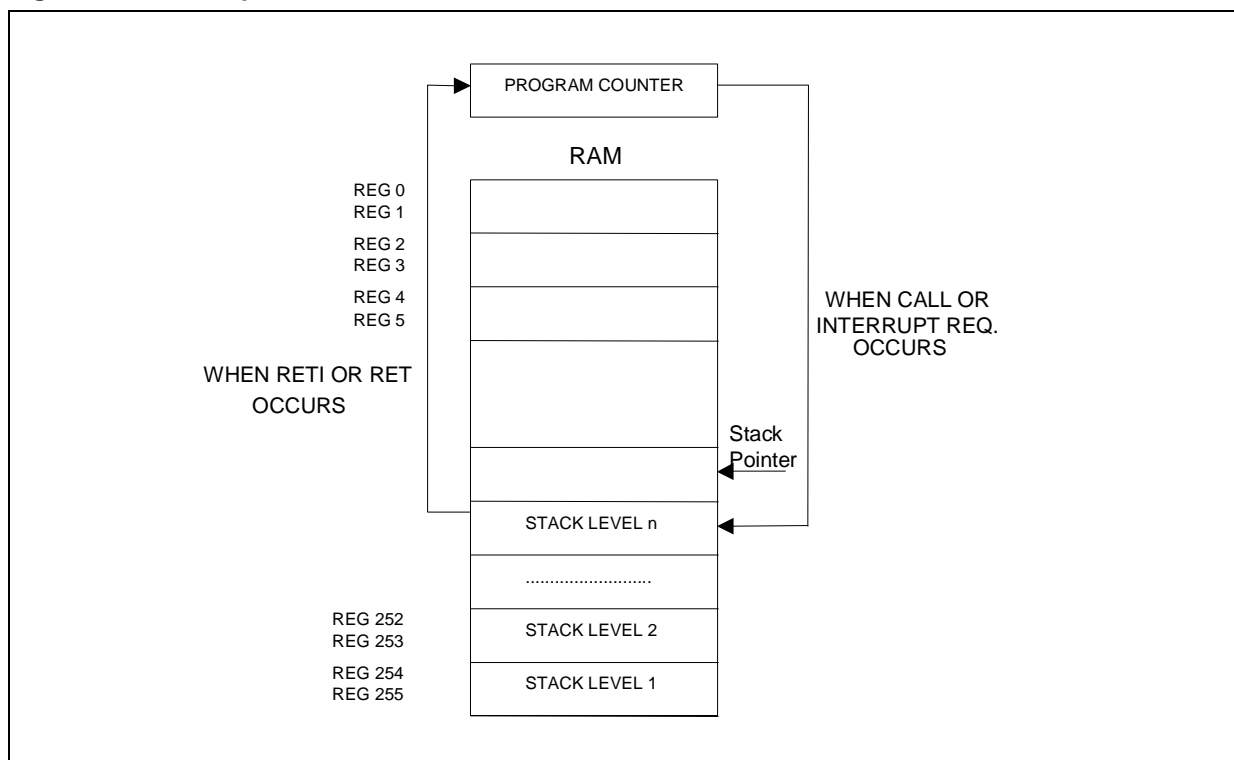

2.2.3 Configuration Registers.

The ST52x400/440/441 Configuration Registers allow the configuration of all the blocks of the ICU. Table 2.2 describes the functions and the related peripherals of the 21 Configuration Registers available: in order to simplify the concept a mnemonic name is assigned to each Configuration Register. The same name is used in VISUAL FIVE™ development tools. By using the load instructions the Configuration Registers may be set by using values stored in the Program Memory (EPROM) or in the RAM.

The assembler instruction *LDCE conf,mem* loads the Configuration Register *conf* with the contents of memory location *mem*, inside the currently set memory page.

The assembler instructions *LDCR conf,reg* loads the Configuration Register *conf* with the contents of the register (RAM location) *reg*.

Use and meaning of each register will be described in further details in the corresponding section.

2.2.4 Output Registers.

The Output Registers (OR) consist of 6 registers containing data for the ICU peripherals including I/O Ports.

All registers can be specified by using a decimal address, e.g. 1 identifies the second OR.

By using the LOAD type instructions the Output Registers (OR) may be set with values stored in the Program Memory (LDPE) or in the RAM (LDPR).

The assembler instruction *LDPE out,mem* loads the Output Register *out* with the contents of memory location *mem*, inside the currently set memory page. The assembler instruction *LDPR out,reg* loads the Output Register *out* with the contents of register (RAM location) *reg*.

Table 2.3 describes the OR: in order to simplify the concept a mnemonic name is assigned to each of the Output Registers. The same name is used in VISUAL FIVE™ development tools. Use and meaning of each register will be described in further details in the corresponding section.

Table 2.1 Input Registers

IR MNEMONIC NAME	PERIPHERAL REGISTER	ADDRESS
STACK_POINTER	STACK POINTER	0
AC_CHAN0H(*)	Analog Comparator CHANNEL 0 High Byte	1
AC_CHAN0L(*)	Analog Comparator CHANNEL 0 Low Byte	2
AC_CHAN1H(*)	Analog Comparator CHANNEL 1 High Byte	3
AC_CHAN1L(*)	Analog Comparator CHANNEL 1 Low Byte	4
AC_CHAN2H(*)	Analog Comparator CHANNEL 2 High Byte	5
AC_CHAN2L(*)	Analog Comparator CHANNEL 2 Low Byte	6
AC_CHAN3H(*)	Analog Comparator CHANNEL 3 High Byte	7
AC_CHAN3L(*)	Analog Comparator CHANNEL 3 Low Byte	8
AC_CHAN4H(*)(**)	Analog Comparator CHANNEL 4 High Byte	9
AC_CHAN4L(*)(**)	Analog Comparator CHANNEL 4 Low Byte	10
AC_CHAN5H(*)(**)	Analog Comparator CHANNEL 5 High Byte	11
AC_CHAN5L(*)(**)	Analog Comparator CHANNEL 5 Low Byte	12
AC_STATUS(*)	Analog Comparator Status Register	13
PORT_A	PORT A INPUT REGISTER	14
PORT_B	PORT B INPUT REGISTER	15
PORT_C (**)	PORT C INPUT REGISTER	16
TRIAC_COUNT	TRIAC DRIVER COUNTER Value	17
PWM_COUNT	PWM/TIMER COUNTER Value	18
PWM_STATUS	TIMER STATUS REGISTER	19

(*) Not used on ST52x400xx versions

(**) Not used on ST52x400F/440F441F versions

Table 2.2 Configuration Registers Description

CONFIGURATION REGISTER	PERIPHERAL	DESCRIPTION
REG_CONF 0	INTERRUPT MASK	Interrupts mask setting, Polarity, Brown Out
REG_CONF 1(*)	ANALOG COMPARATOR	AC Configuration Register 1
REG_CONF 2	WATCHDOG TIMER	Watchdog Timer Configuration
REG_CONF 3(*)	ANALOG COMPARATOR	AC Configuration Register 2
REG_CONF 4	PORT A	PORT A digital pin I/O direction
REG_CONF 5	PWM/TIMER	PWM/TIMER Working mode Configuration
REG_CONF 6	PWM/TIMER	PWM/TIMER Prescaler configuration and output waveform selection.
REG_CONF 7	PWM/TIMER	PWM/TIMER Prescaler settings
REG_CONF 8	PWM/TRIAC	PWM/TRIAC Prescaler settings
REG_CONF 9	PWM/TRIAC	PWM/TRIAC Prescaler configuration and output waveform selection.
REG_CONF 10	PWM/TRIAC	PWM/TRIAC Working mode Configuration
REG_CONF 11	PORT C	PORT C digital pin I/O direction
REG_CONF 12	PORT A	PORT A Alternate function settings
REG_CONF 13	PORT B	PORT B digital pin I/O direction
REG_CONF 14(*)	PORT B	PORT B settings for digital or analog pin
REG_CONF 15(*)	ANALOG COMPARATOR	Analog Comparator Prescaler settings
REG_CONF 16(*)	ANALOG COMPARATOR	Analog Comparator in A/D working mode
REG_CONF 17	INTERRUPT	Interrupt priorities
REG_CONF 18	INTERRUPT	Interrupt priorities
REG_CONF 19	TRIAC	TRIAC Pulses Width Configuration
REG_CONF 20	TRIAC	TRIAC Pulses Width Configuration

(*) *Not used on ST52x400xx versions*

Table 2.3 Output Registers

OR MNEMONIC NAME	PERIPHERAL REGISTER	ADDRESS
PORT_A	PORT A OUTPUT REGISTER	0
PORT_B	PORT B OUTPUT REGISTER	1
PORT_C (**)	PORT C OUTPUT REGISTER	2
PWM_COUNT	TIMER/PWM COUNTER Value	3
PWM_RELOAD (*)	PWM/TIMER RELOAD Value	4
	not used	5
	not used	6
	not used	7
	not used	8
TRIAC_COUNT	TRIAC DRIVER COUNTER Value	9

(*) *Used if Peripheral has been programmed in PWM Mode* (**) *Not used on ST52x400F/440F/441F versions*

2.3 Fuzzy Computation

ST FIVE's Fuzzy main features are:

- Up to 8 Inputs with 8-bit resolution;
- 1 Kbyte of Program/Data Memory available to store more than 300 to Membership Functions (Mbfs) for each Input;
- Up to 128 Outputs with 8-bit resolution;
- Possibility to process fuzzy rules with an UNLIMITED number of antecedents
- UNLIMITED number of Rules and Fuzzy Blocks. The limits on the number of Fuzzy Rules and fuzzy Blocks are only related to the program memory size.

2.3.1 Fuzzy Inference .

The block diagram illustrated in Figure 2.7 describes the different steps performed during a fuzzy algorithm. The ST FIVE Core allows the implementation of a MAMDANI type fuzzy inference with crisp consequents. Inputs for fuzzy inference are stored in 8 dedicated Fuzzy input registers. The instruction LDFR is used to set the input fuzzy registers with values stored in the Register File. The result of a fuzzy inference is stored directly in a location of the Register File.

Figure 2.6 Alpha Weight Calculation

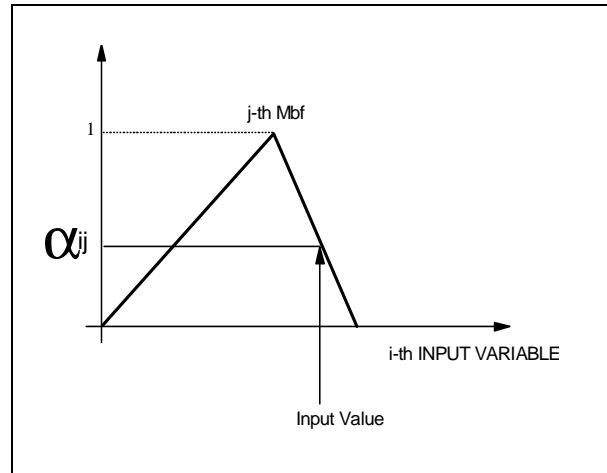

2.3.2 Fuzzyfication Phase.

In this phase the intersection (alpha weight) between the input values and the related Mbfs is performed (Figure 2.6).

8 Fuzzy input registers are available for fuzzy inferences.

After loading the input values by using the LDFR assembler instruction, the user can start fuzzynference by using the assembler instructionFUZZY. During fuzzyfication: input data is transformed in the activation level (alpha weight) of the Mbfs. i

Figure 2.7 Fuzzy Inference

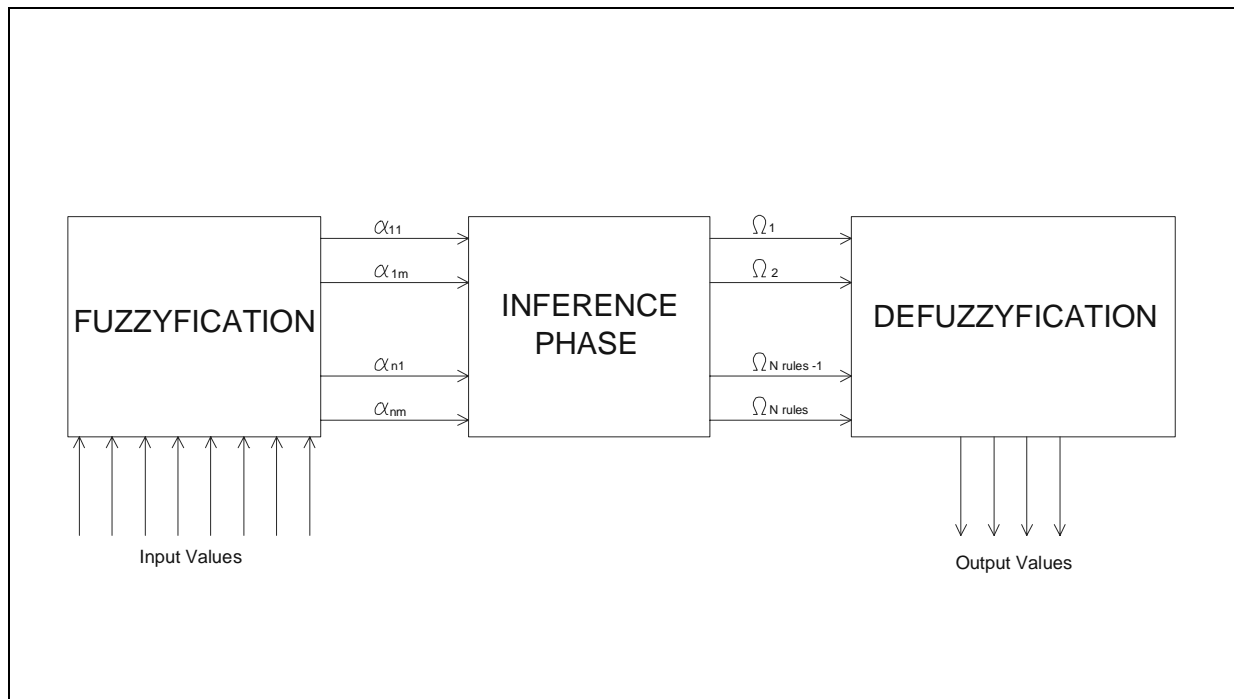

2.3.3 Inference Phase.

The Inference Phase manages the alpha weights obtained during the fuzzyfication phase to compute the truth value (ω) for each rule.

This is a calculation of the maximum (for the OR operator) and/or minimum (for the AND operator) performed on alpha values according to the logical connectives of fuzzy rules.

Several conditions may be linked together by linguistic connectives AND/OR, NOT operator and brackets.

The truth value ω and the related output singleton-move to the Defuzzification phase in order to complete the inference calculation.

Figure 2.8 Fuzzyfication

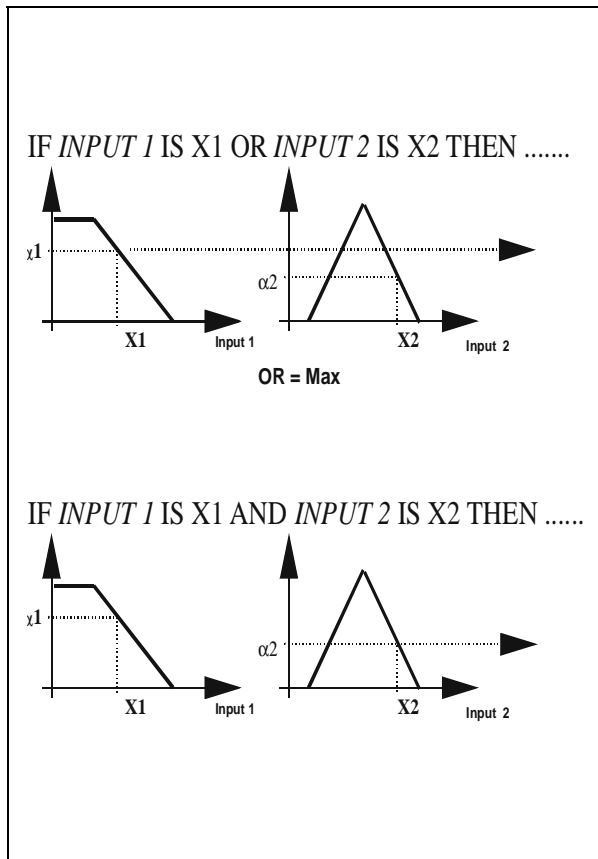
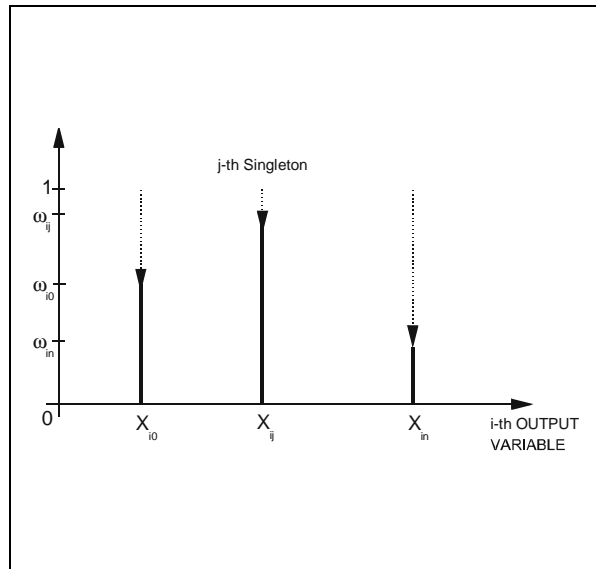

Figure 2.9 Output Membership Functions



2.3.4 Defuzzification.

In this phase the output crisp values are determined by implementing the consequent part of the rules.

Each consequent Singleton X_i is multiplied by its weight values ω_i , calculated by the Fuzzy Inference Unit, in order to compute the upper part of the defuzzification.

Each output value is deduced from the consequent crisp values (X_i) by carrying out the following defuzzification formula:

where:

$$Y_i = \frac{\sum_j X_{ij} \omega_{ij}}{\sum_j \omega_{ij}}$$

$i = 0,1$ identifies the current output variable

N = number of the active rules on the current output

ω_{ij} =weight of the j -th singleton

X_{ij} = abscissa of the j -th singleton

Fuzzy outputs are stored in the RAM location i -th specified in the assembler instruction OUT i .

2.3.5 Input Membership Function.

ST FIVE allows the management of triangular Mbfs. In order to define an Mbf, three different types of data must be stored on the Program/Data Memory:

the vertex of the Mbf: **V**;

the length of the left semi-base: **LVD**;

the length of the right semi-base: **RVD**;

In order to reduce the size of the memory area and the computational effort the vertical dimension of the vertex is set to 15 (4 bits).

By using the previous memorization method different kinds of triangular Membership Functions may be stored. Figure 4.6 illustrates a typical example of Mbfs that can be defined in ST FIVE.

Each Mbf is then defined storing 3 bytes in the first 1 Kbyte of the program memory.

The Mbf is memorized by using the following instruction:

MBF n_mbf lvd v rvd

where

n_mbf identifies Mbf, lvd, v, and rvd, which are the parameters that describe the Mbf's shape.

2.3.6 Output Singleton.

ST FIVE uses a particular kind of membership function called Singleton for its output variables. A Singleton doesn't have a shape, like a traditional Mbf, and is characterized by a single point identified by the couple (X, w), where the w is calculated by the Inference Unit as described before.

Often, a Singleton is simply identified with its Crisp Value X.

2.3.7 Fuzzy Rules.

Rules can have the following structures:

if A op B op C.....then Z

if (A op B) op (C op D op E...).....then Z

where op is one of the possible linguistic operators (AND/OR)

In the first case the rule operators are managed sequentially; in the second one, the priority of the operator is fixed by the brackets.

Each rule is codified by using an instruction set, the inference time for a rule with 4 antecedents and 1 consequent is about 3 microseconds.

Figure 2.10 Mbfs Parameters

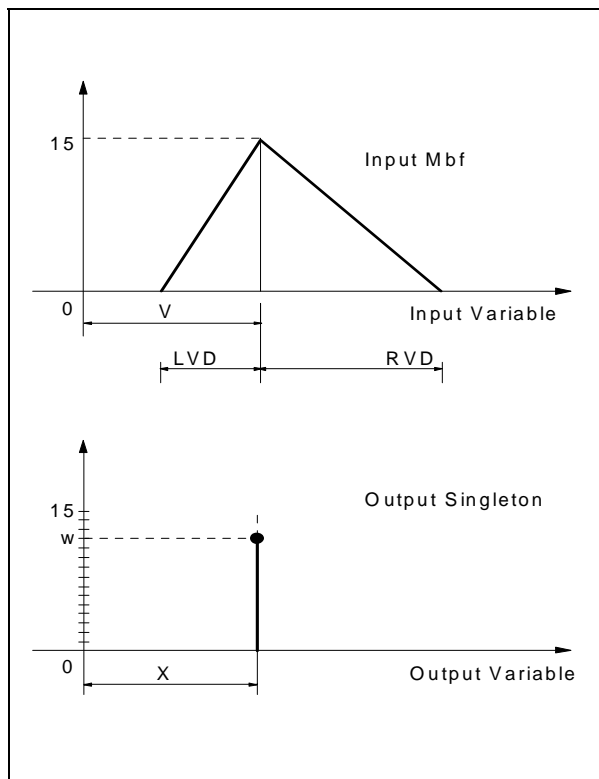
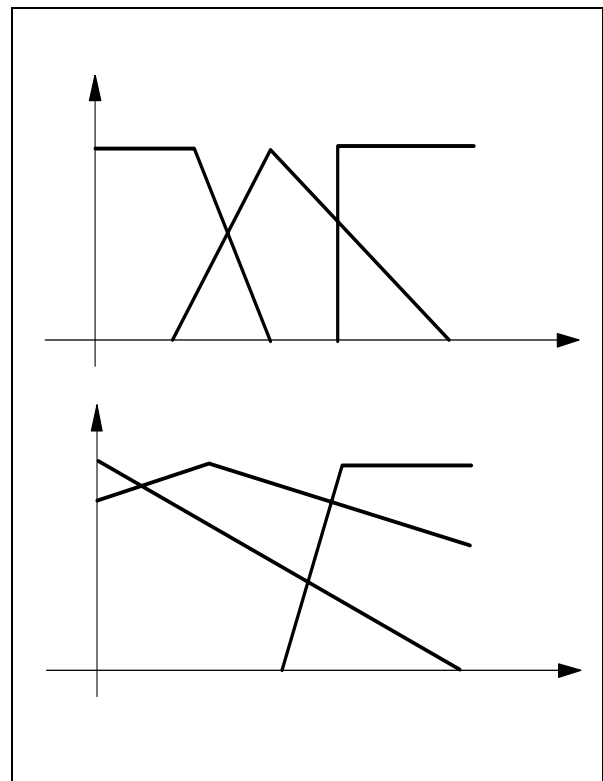

Figure 2.11 Example of valid Mbfs



The assembler Instruction Set, which manages fuzzy instructions is reported in the following table:

Table 2.4 Fuzzy Instruction Set

Instruction	Description
MBF <i>n_mbf lvd v rvd</i>	Stores the Mbf <i>n_mbf</i> with the shape identified by the parameters <i>lvd</i> , <i>v</i> and <i>rvd</i>
LDP <i>n m</i>	Fixes the alpha value of the input <i>n</i> with the Mbf <i>m</i> and stores it in internal registers
LDN <i>n m</i>	Calculates the complementary alpha value of the input <i>n</i> with the Mbf <i>m</i> . and stores the result in internal registers
FZAND	Implements the Fuzzy operation AND between the last two values stored in internal registers
FZOR	Implements the Fuzzy operation OR between the last two values stored in internal registers
LDK	Stores the result of the last Fuzzy operation executed in internal registers
SKM	Loads the result of the last performed Fuzzy operation (stored in the temporary register K) in the temporary buffer M.
LDM	Copies the value of register M in the data stack
CON <i>crisp</i>	Multiplies the <i>crisp</i> value with the last ω weight
OUT <i>n_out</i>	Performs Defuzzification and stores the currently Fuzzy output in the RAM <i>n_out</i> location
FUZZY	Starts the Fuzzy algorithm

Example 1:

IF Input₁ IS NOT Mbf₁ AND Input₄ IS Mbf₁₂ OR Input₃ IS Mbf₈ THEN Crisp₁

is codified by the following instructions:

LDN 1 1 calculates the NOT α value of Input₁ with Mbf₁ and stores the result in internal registers

LDP 4 12 fixes the α value of Input₄ with M₁₂ and stores the result in internal registers

FZAND adds the NOT α and α values obtained with the operations LDN1 1 and LDP 4 12

LDK stores the result of the operation FZAND in internal registers

LDP 3 8 fixes the α value of Input₃ with Mbf₈ and stores the result in internal registers

FZOR implements the operation OR between the results obtained with the operations LDK and LDP

CON crisp₁ multiplies the result of the last Ω operation with the crisp value Crisp₁

Example 2, the priority of the operator is fixed by the brackets:

IF (Input₃ IS Mbf₁ AND Input₄ IS NOT Mbf₁₅) OR (Input₁ IS Mbf₆ OR Input₆ IS NOT Mbf₁₄) THEN Crisp₂

LDP 3 fixes the α value of Input₃ with Mbf₁ and stores the result in internal registers

LDN 4 15 calculates the NOT α value of Input₄ with Mbf₁₅ and stores the result in internal registers

FZAND adds NOT α and α values obtained with the operations LDP 3 1 and LDN 4 15 SKM
stores the result of the operation FZAND in internal registers

LDP 1 6 fixes the α value of Input₁ with Mbf₆ and stores the result in internal registers

LDN 2 14 calculates the NOT α value of Input₆ with Mbf₁₄ and stores the result in internal registers

FZOR implements the operation OR between the α and NOT α values obtained with the two previous operations (LDP 1 6 and LDN 2 14)

LDK stores the result of the operation OR in internal registers

LDM copies the value of the memory register M in internal registers

FZOR implements the operation OR between the last two values stored in internal registers (LDK and LDM)

CON crisp₂ multiplies the result of the last Ω operation with the crisp value Crisp₂

At the end of the fuzzy rule, by using the instruction OUT RAM_reg, a byte is written. Afterwards, the control of the algorithm goes returns to the CU.

2.4 Arithmetic Logic Unit

ST52x400/440/441 supplies 46 instructions that perform computations and control the device. Computational time required for each instruction consists of one clock pulse for each Cycle plus 2 clock pulses for the decoding phase. Total computation time for each instruction is reported in Table 2.5

The ALU of the ST52x400/440/441 can perform multiplication (MULT) and division (DIV). Multiplication is performed by using 8 bit operands storing the result in 2 registers (16 bit values).

Division is performed between a 16 bit dividend and an 8 bit divider, the result and the remainder are stored in two 8-bit registers.

WARNING: *If the LSB of the multiplication result is 0, the Zero flag is set although the result is not 0.*

2.4.1 Addressing Modes.

ST52x400/440/441 instructions allow the following addressing modes:

Inherent: this instruction type does not require an operand because the opcode specifies all the information necessary to carry out the instruction. Examples: NOP, RET.

Immediate: these instructions have an operand as a source immediate value. Examples: LDRC,

PGSET.

Direct: the operands of these instructions are specified with the direct addresses. The operands can refer, according to the opcode, to addresses belonging to the different addressing spaces. Example: SUB, LDRE.

Indirect: data addresses that are required are found in the locations specified as operands. Both source and/or destination operands can be addressed indirectly. The operands can refer, (according to the opcode) to addresses belonging to different addressing spaces. Examples: LDRE (reg1),(reg2).

2.4.2 Instruction Types.

ST FIVE supplies the following instruction types:

- Load Instructions
- Arithmetic and Logic Instructions
- Jump Instructions
- Interrupt Management Instructions
- Control Instructions

The instructions are listed in Table 2.5, Table 2.6 and Table 2.7.

Table 2.5 Arithmetic & Logic Instruction Set

Load Instructions						
Mnemonic	Instruction	Bytes	Cycles	Z	S	C
LDCE	LDCE confx,memx	3	17	-	-	-
LDCR	LDRC confx,regx	3	14	-	-	-
LDFR	LDFR fuzzyx,regx	3	14	-	-	-
LDPE	LDPE outx,memx	3	17	-	-	-
LDPE	LDPE outx,(regx)	3	17	-	-	-
LDPR	LDPR outx,regx	3	14	-	-	-
LDRC	LDRC regx,const	3	14	-	-	-
LDRE	LDRE regx,memx	3	16	-	-	-
LDRE	LDRE (regx),(regy)	3	18	-	-	-
LDRI	LDRI regx,inx	3	15	-	-	-
LDRR	LDRR regx, regy	3	16	-	-	-
PGSET	PGSET const	2	9	-	-	-

Table 2.6 Arithmetic and Logic Instruction Set (Continued)

Arithmetic Instructions						
Mnemonic	Instruction	Bytes	Cycles	Z	S	C
ADD	ADD regx, regy	3	17		-	
ADDO	ADDO regx, regy	3	20			
AND	AND regx, regy	3	17		-	-
ASL	ASL regx	2	15		-	
ASR	ASR regx	2	15			-
DEC	DEC regx	2	15			-
DIV	DIV regx, regy	3	26			
INC	INC regx	2	15		-	
MULT	MULT regx, regy	3	19		-	-
NOT	NOT regx	2	15		-	-
OR	OR regx, regy	3	17		-	-
SUB	SUB regx, regy	3	17			-
SUBO	SUBO regx, regy	3	20			
MIRROR	MIRROR regx	2	15		-	-

Jump Instructions						
Mnemonic	Instruction	Bytes	Cycles	Z	S	C
CALL	CALL addr	3	18	-	-	-
JP	JP addr	3	12	-	-	-
JPC	JPC addr	3	10/12	-	-	-
JPNC	JPNC addr	3	10/12	-	-	-
JPNS	JPNS addr	3	10/12	-	-	-
JPNZ	JPNZ addr	3	10/12	-	-	-
JPS	JPS addr	3	10/12	-	-	-
JPZ	JPZ addr	3	10/12	-	-	-
RET	RET	1	13	-	-	-

Interrupt Instructions Set						
Mnemonic	Instruction	Bytes	Cycles	Z	S	C
HALT	HALT	1	7/15	-	-	-
MEGI	MEGI	1	7/15	-	-	-
MDGI	MDGI	1	6	-	-	-
RETI	RETI	1	12	-	-	-
RINT	RINT const	2	8	-	-	-
UDGI	UDGI	1	6	-	-	-
UEGI	UEGI	1	7/15	-	-	-
WAITI	WAITI	1	7/14	-	-	-

Table 2.7 Control Instructions Set

Control Instructions set						
Mnemonic	Instruction	Bytes	Cycles	Z	S	C
FUZZY	FUZZY	1	5	-	-	-
NOP	NOP	1	6	-	-	-
WDTRFR	WDTRFR	1	7	-	-	-
WDTSLP	WDTSLP	1	6	-	-	-

Notes:

| flag affected

- flag not affected

regx, regy: Register File addresses

memx, memy: Program/Data Memory addresses

confx, confy: Configuration Registers addresses

outx: Output Registers addresses

inpx: Input Registers addresses

const: constant value

fuzzyx: Fuzzy Input Register

addr: Program instructions address

Figure 2.12 Multiplication

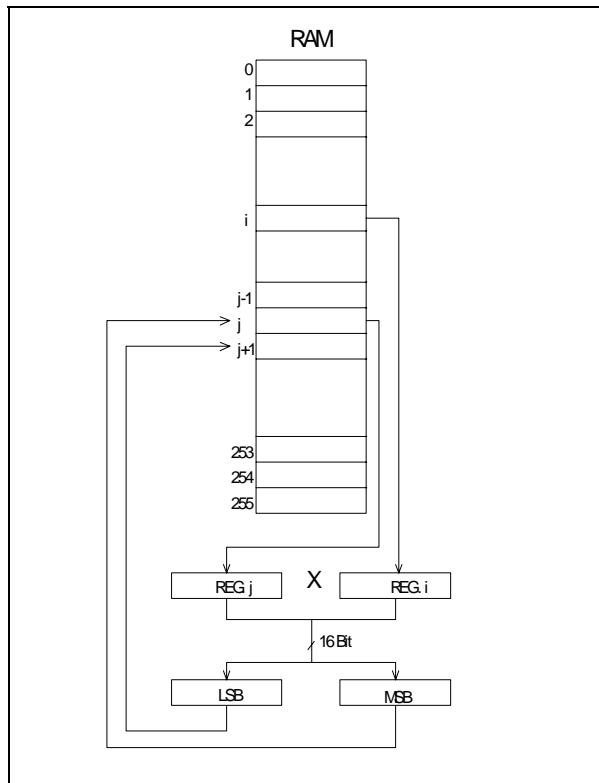
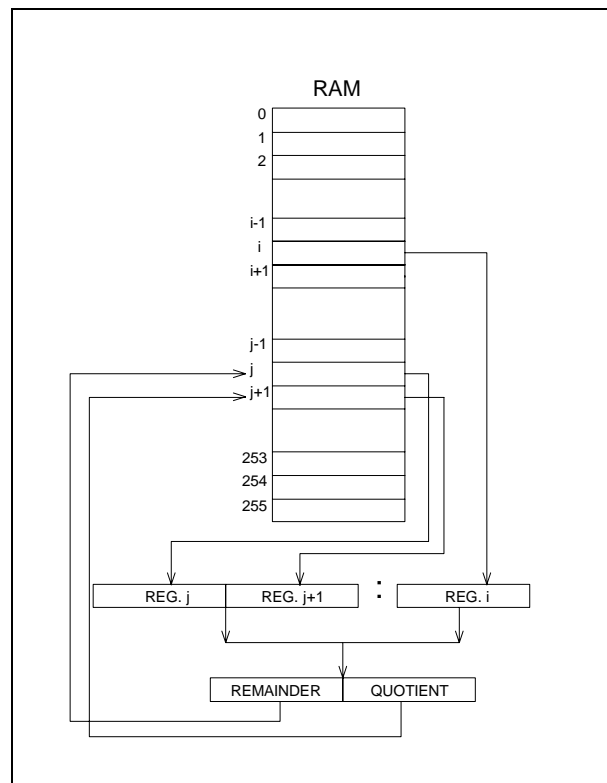

Figure 2.13 Division



3 EPROM PROGRAMMING

EPROM memory provides an on-chip user-programmable non-volatile memory, which allows fast and reliable storage of user data.

EPROM memory can be locked by the user. In fact, a memory location, called Lock Cell, is devoted to lock the EPROM and to prevent

memory reading. A software identification code (max 64 bytes), called ID CODE may also be written in order to distinguish which software version is stored in the memory.

There are 64 kbits of memory space with an 8-bit internal parallelism (8 kbytes) addressed by a 13-bit bus. The data bus is of 8 bits.

Memory has a double supply: V_{PP} is equal to $12V \pm 5\%$ in Programming Phase or to V_{SS} during Working Phase. V_{DD} is equal to $5V \pm 10\%$.

The ST52x400/440/441 EPROM memory is divided into three main blocks (see Figure 3.1):

- *Interrupt Vectors memory block* (3 through 14) contains the addresses for the interrupt routines. Each address is composed of three bytes.
- *Mbfs Setting memory block* (15 through 1024) contains the coordinates of the vertexes of every Mbfs defined in the program. If this part of the memory is not used to store the Mbfs setting, it can be use to store the instruction set on the user program.
- *The Program Instruction Set memory block* (1024 through 8191) contains the instruction set of the user program.

Table 3.1 EPROM Control Register

OPERATION	REGISTER VALUE
Stand By	0
Memory Reading / Verify	1
Memory Unlock and Lock Status Reading	2
Memory Writing	3
Memory Lock	4
ID CODE Writing	5
Memory Lock Status Reading / Verify	9
ID CODE Reading / Verify	10

Figure 3.1 Program Memory Organization

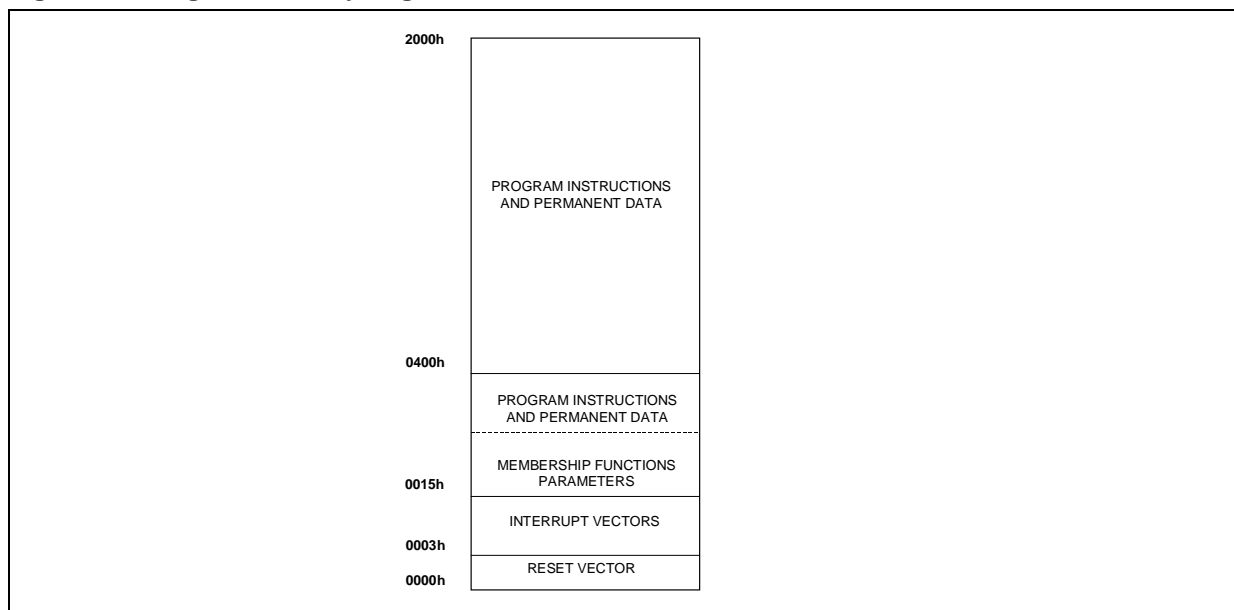

The locations 0, 1 and 2 contain the jump instruction to the first code line. This instruction is automatically inserted by the Assembler tool. The operations that can be performed on EPROM during the Programming Phase are: Stand By, Memory Writing, Reading and Verify/Margin Mode, Memory Lock, IDCode Writing and Verify.

The operations above are managed by using the 4-bit EPROM Control Register. The reading phase is executed with $V_{PP}= 5V\pm 5\%$, while the verify/Margin Mode phase needs $V_{PP}= 12V\pm 5\%$. The Blank Check must be a reading operation with $V_{PP}= 5V\pm 5\%$.

Table 3.1 illustrates the EPROM Control Register codes used to select the operation. Programming of the EPROM Control Register is described below.

3.1 EPROM Programming Phase Procedure

Programming mode is selected by applying $12V\pm 5\%$ voltage or $5V\pm 5\%$ voltage to the V_{PP} pin and setting the RESET pin = V_{SS}

If the V_{PP} voltage is $5V\pm 5\%$ only reading may be performed.

RST_ADD (PB0), INC_ADD (PB1), RST_CONF (PB2), INC_CONF (PB3) and PHASE (PB7) are

the control signals applied during Programming Mode.

The signals RST_ADD, RST_CONF and PHASE are active on level, the others are active on rising edge.

The signals RST_ADD and PHASE are active low, signal on RST_CONF is active high.

Data in/out digital signals are transferred through the pins of Port A.

The memory may be locked by means of the Memory Lock Status flag, that is used to enable EPROM operations.

If Memory Lock Status flag is 1 all EPROM operations are enabled, otherwise, it is only possible to read (and verify) the OTP code and the Memory Lock Status flag.

Only If EPROM is not locked by means of Lock Cell (see paragraph EPROM Locking), may EPROM operations be enabled, changing the Memory Lock Status flag from 0 to 1.

The signal RST_ADD (PB0) resets the memory address register and the Memory Lock Status flag. Therefore, when the RST_ADD becomes high, the memory must be unlocked in order to read or write.

The signal RST_CONF (PB2) resets the EPROM,

Figure 3.2 EPROM Programming Timing

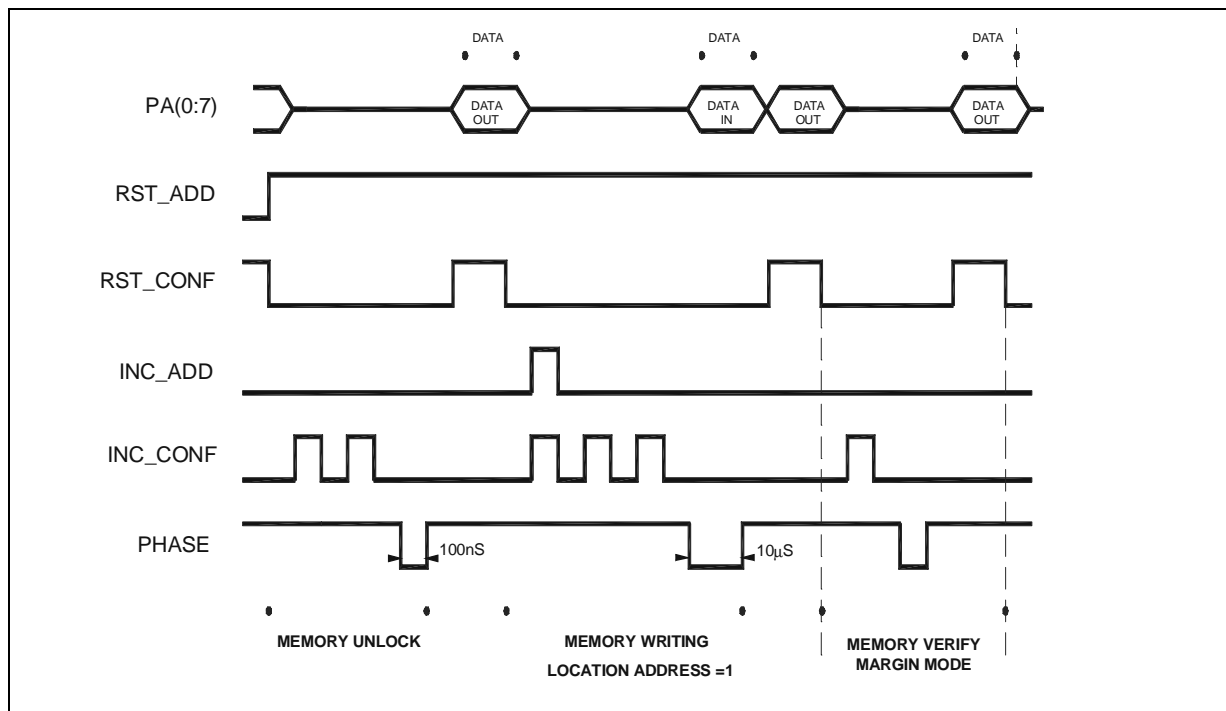

INC_ADD (PB1) signal increments the memory address. Control Register. **When RST_CONF is high, the DATA I/O Port A is in output, otherwise it is always in input.**

The signal applied on INC_CONF (PB3) increments the EPROM Control Register value. To select the operation it must be provided as many signal edges as the value to be written in the register (see Table 3.1).

The signal on PHASE (PB7) validates the operation selected by means of the EPROM Control Register value.

3.1.1 EPROM Operation. In order to execute an EPROM operation (see Table 3.1), the corresponding identification value must be loaded in the EPROM Control Register. The signal timing is the following: RST_ADD= high and PHASE= high, RST_CONF changes from low to high level, to reset the EPROM Control Register, and INC_CONF signal generates a number of positive pulses equal to the value to be loaded. After this sequence, a negative pulse of the PHASE signal will validate the selected operation. The minimum PHASE signal pulse width must be 10 μ s for the EPROM Writing Operation and 100 ns for the others.

When RST_CONF is high, the DATA I/O Port A is enabled in output and the reading/verify operation results are available.

After a writing operation, when RST_CONF is high, Port A is in output without valid data.

3.1.2 EPROM Locking. The Memory Lock operation, which is identified with the number 4 in the EPROM Control Register, writes "0" in the Memory Lock Cell.

At the beginning of an External Operation, when RST_ADD signal changes from low level to high level, the Memory Lock Status flag is "0", therefore it is necessary to unlock it before proceeding.

In order to unlock the Memory Lock Status flag the operation, which is identified with the number 2 in the EPROM Control Register must be executed (see Figure 3.2).

The Memory Lock Status flag can be changed. Therefore, after a Memory Lock operation, external operations cannot be executed except reading (or verify) the OTP Code and the Memory Lock Status.

3.1.3 EPROM Writing. When the memory is blank, all the bits are at logic level "1". The data is introduced by programming only the zeros in the desired memory location; however, all input data must contain both "1" and "0". The only way to change "0" into "1" is to erase the whole memory (by exposure to UV light) and reprogram it.

The memory is in Writing mode when the EPROM Control Register value is 3.

The V_{PP} voltage must be $12V \pm 5\%$, with stable data on the data bus PB(0:7). The signals timing is the following (see Figure 3.2):

- 1) RST_ADD and RST_CONF change from low to high level,
- 2) two pulses on INC_CONF signal load the Memory Unlock operation code,
- 3) a negative pulse (100 ns) on the PHASE signal validates the Memory Unlock operation,
- 4) a negative pulse on RST_CONF signal resets the EPROM Control Register,
- 5) three positive pulses on INC_CONF load the Memory Writing operation code,
- 6) a train of positive pulses on INC_ADD signal increments the memory location address up to the requested value (generally this is a sequential operation and only one pulse is used),
- 7) a negative pulse (10 μ s) on the PHASE signal validates the Memory Writing operation.

3.1.4 EPROM Reading/Verify Margin Mode.

The reading phase is executed with $V_{PP} = 5V \pm 5\%$, instead of verify phase that needs $V_{PP} = 12V \pm 5\%$.

The Memory Verify operation is available in order to verify the correctness of the data written. The Memory Verify Margin Mode operation may be executed immediately after the writing of each byte and in this case (see Figure 3.2):

- 1) one positive pulse on RST_CONF signal resets the Control Register, if it was not already reset
- 2) one positive pulse on INC_CONF loads the Memory Reading/Verify operation code,
- 3) one negative pulse (100 ns) on the PHASE signal validates the Memory Reading/Verify operation,
- 4) a negative pulse on RST_CONF signal puts in the PB(0:7) port the value stored in the actual memory address and resets the EPROM Control Register.

Then, if any error in writing occurred, the user has to repeat the EPROM writing.

3.1.5 Stand by Mode. EPROM has a standby mode which reduces the active current from 10mA (Programming mode) to less than 100 μ A. Memory is placed in standby mode by setting PHASE signal at high level or when the EPROM Control Register value is 0 and PHASE signal is low.

3.1.6 ID code. A software identification code, called ID code may be written to distinguish which software version is stored in the memory.

64 Bytes are dedicated to store this code by using the address values from 0 to 63.

The ID Code may be read or verified even if the Memory Lock Status is "0".

The signals timing is the same as that of a normal operation.

3.2 Eprom Erasure

Thanks to the transparent window available in the CDIP28W package, its memory contents may be erased by exposure to UV light.

Erasure begins when the device is exposed to light with a wavelength shorter than 4000Å. It should be noted that sunlight, as well as some types of artificial light, includes wavelengths in the 3000-4000Å range which, on prolonged exposure, can cause erasure of memory contents. It is thus recommended that EPROM devices be fitted with an opaque label over the window area in order to prevent unintentional erasure.

The recommended erasure procedure for EPROM devices consists of exposure to short wave UV light having a wavelength of 2537Å. The minimum recommended integrated dose (intensity x exposure time) for complete erasure is 15Wsec/cm².

This is equivalent to an erasure time of 5-10 minutes using a UV source having an intensity of 12mW/cm² at a distance of 25mm (1 inch) from the device window.

4 INTERRUPTS

The Control Unit (CU) responds to peripheral events and external events via its interrupt channels.

When such an event occurs, if the related interrupt is not masked and according to a priority order, the current program execution can be suspended to allow the CU to execute a specific response routine.

Each interrupt is associated with an interrupt vector that contains the memory address of the related interrupt service routine. Each vector is located in the Program Space (EPROM Memory) at a fixed address (see Interrupt Vectors Figure 4.2).

4.1 Interrupt Operation

If there are pending interrupts at the end of an arithmetic or logic instruction, the one with the highest priority is passed. Passing an interrupt means to store the arithmetic flags and the current PC in the stack and execute the associated Interrupt routine, whose address is located in three bytes of the EPROM memory location between address 3 and 20.

The Interrupt routine is performed as a normal code checking, at the end of each instruction, if a higher priority interrupt has to be passed. An Interrupt request with the higher priority stops the lower priority Interrupt. The Program Counter and the arithmetic flags are stored in the stack.

With the instruction RETI (Return from Interrupt) the arithmetic flags and Program Counter (PC) are restored from the top of the stack, which was previously described in Section 2.2.1.

An Interrupt request cannot stop fuzzy rule processing, but this is passed only after the end of a fuzzy rule or at the end of a logic, or arithmetic instruction.

REMARK: A fuzzy routine can be interrupted only in the Main program. When a Fuzzy function is running inside another interrupt routine an interrupt request can cause side effects in the Control Unit. For this reason, in order to use a Fuzzy function inside an interrupt routine, the user **MUST** include the Fuzzy function between an UDGI (MDGI) instruction and a UEGI (MEGI) instruction (see the following paragraphs), in order to disable the interrupt request during the execution of the fuzzy function.

Figure 4.1 Interrupt Flow

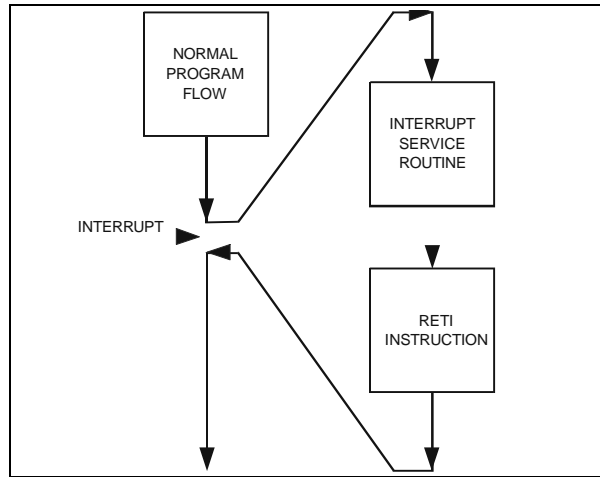

Figure 4.2 Interrupt Vectors Mapping

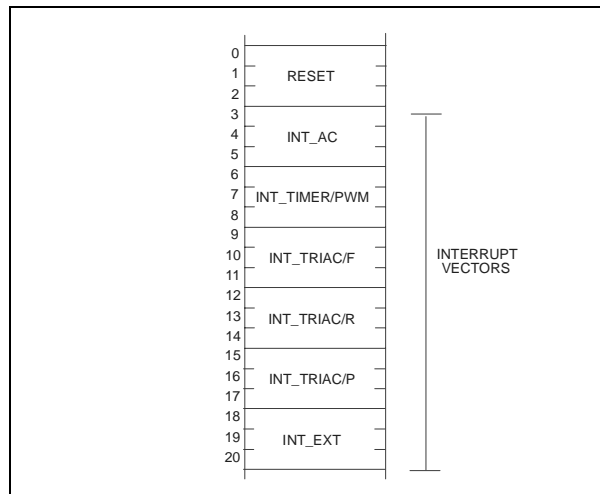
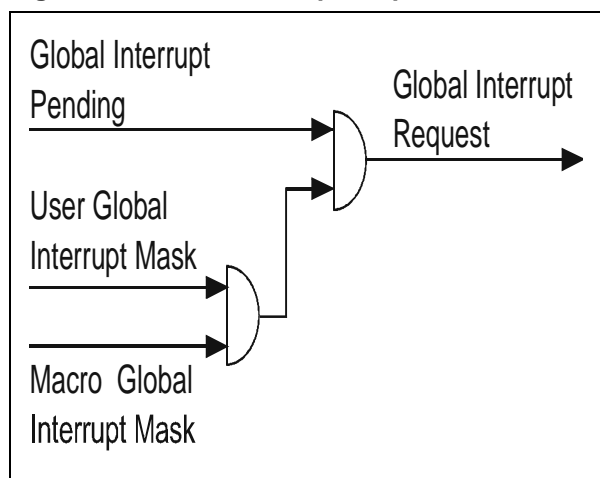

Figure 4.3 Global Interrupt Request Generation



4.2 Global Interrupt Request Enabling

When an Interrupt occurs, it generates a Global Interrupt Pending (GIP), which can be masked by software. After a GIP, a Global Interrupt Request (GIR) will be generated and an Interrupt Service Routine associated to the interrupt with higher priority will start. In order to avoid possible conflicts between interrupt masking set in the main program, or inside macros, the GIP is masked through the User Global Interrupt Mask or the Macro Global Interrupt Mask (see Figure 4.3).

UEGI/UDGI instruction switches the User Global Interrupt Mask on/off, enabling/disabling the GIR for the main program.

MEGI/MDGI instructions switches the Macro Global Interrupt Mask on/off in order to ensure that the macro will not be broken.

4.3 Interrupt Sources

ST52x400/440/441 manages interrupt signals generated by the internal peripherals (PWM/TIMER, TRIAC Driver and Analog Comparator) or deriving from the External Interrupt on pin PA7. The External Interrupt can be programmed to be active on the rising or falling edge of INT/PA7 signal by setting the PEXTINT bit of the Configuration Register to 0.

WARNING: *Changing the interrupt priority an interrupt request is generated.*

Each peripheral can be programmed in order to generate the associated interrupt; further details are described in the related chapter. Configuration Register 0 is also used to enable/disable the Brown-Out (see the related chapter).

4.4 Interrupt Maskability

The interrupts can be masked by configuring the Configuration Register 0 by means of an LDCR or an LDCE instruction. The interrupt is enabled when the bit associated to the mask interrupt is "1". Viceversa, when the bit is "0", the interrupt is masked and is kept pending.

For example:

LDCR 10,6 (loads the constant 6 in the RAM Register 10)

LDCR 0,10 (sets REG_CONF0 with the value stored in RAM Register 10)

the result is REG_CONF0=00000110, enabling the interrupts coming from the Analog Comparator (INT_AC) and from the PWM/TIMER (INT_PWM/TIMER).

Table 4.1 Configuration Register 0 Description

Bit	Name	Value	Description
0	MSKE	0	External Interrupt Masked
		1	External Interrupt Not Masked
1	MSKAC(*)	0	Analog Comparator Interrupt Masked
		1	Analog Comparator Interrupt Not Masked
2	MSKTM	0	PWM/TIMER Interrupt Masked
		1	PWM/TIMER Interrupt Not Masked
3	MSKTRF	0	TRIAC Falling Edge Interrupt
		1	TRIAC Falling Edge Interrupt Not Masked
4	MSKTRR	0	TRIAC Rising Edge Interrupt Masked
		1	TRIAC Rising Edge Interrupt Not Masked
5	MSKTRP	0	TRIAC Pulse Interrupt Masked
		1	TRIAC Pulse Interrupt Not Masked
6	PEXTINT	0	External Interrupt active on Rising Edge
		1	External Interrupt active on Falling Edge
7	MSKBR	0	Brown-Out Disabled
		1	Brown-Out Enabled

Reset Configuration '00000000'
 (*) Not Used in ST52x400 devices

Table 4.2 Interrupts Description

Name	Description		Priority	Peripheral Code	Maskable	Vector Addresses
INT_AC(*)	Analog Comparator	Int	Programmable	000	yes	3-5
INT_PWM/TIMER	PWM/TIMER	Int	Programmable	001	yes	6-8
INT_TRIAC/F	TRIAC Falling Edge	Int	Programmable	010	yes	9-11
INT_TRIAC/R	TRIAC rising edge	Int	Programmable	011	yes	12-14
INT_TRIAC/P	TRIAC Pulse	Int	Programmable	100	yes	15-17
INT_EXT	External Interrupt (INT)	Ext	Highest	-	yes	18-20

(*) Used only in ST52x440/441 devices

Figure 4.4 Interrupt Configuration Register 0

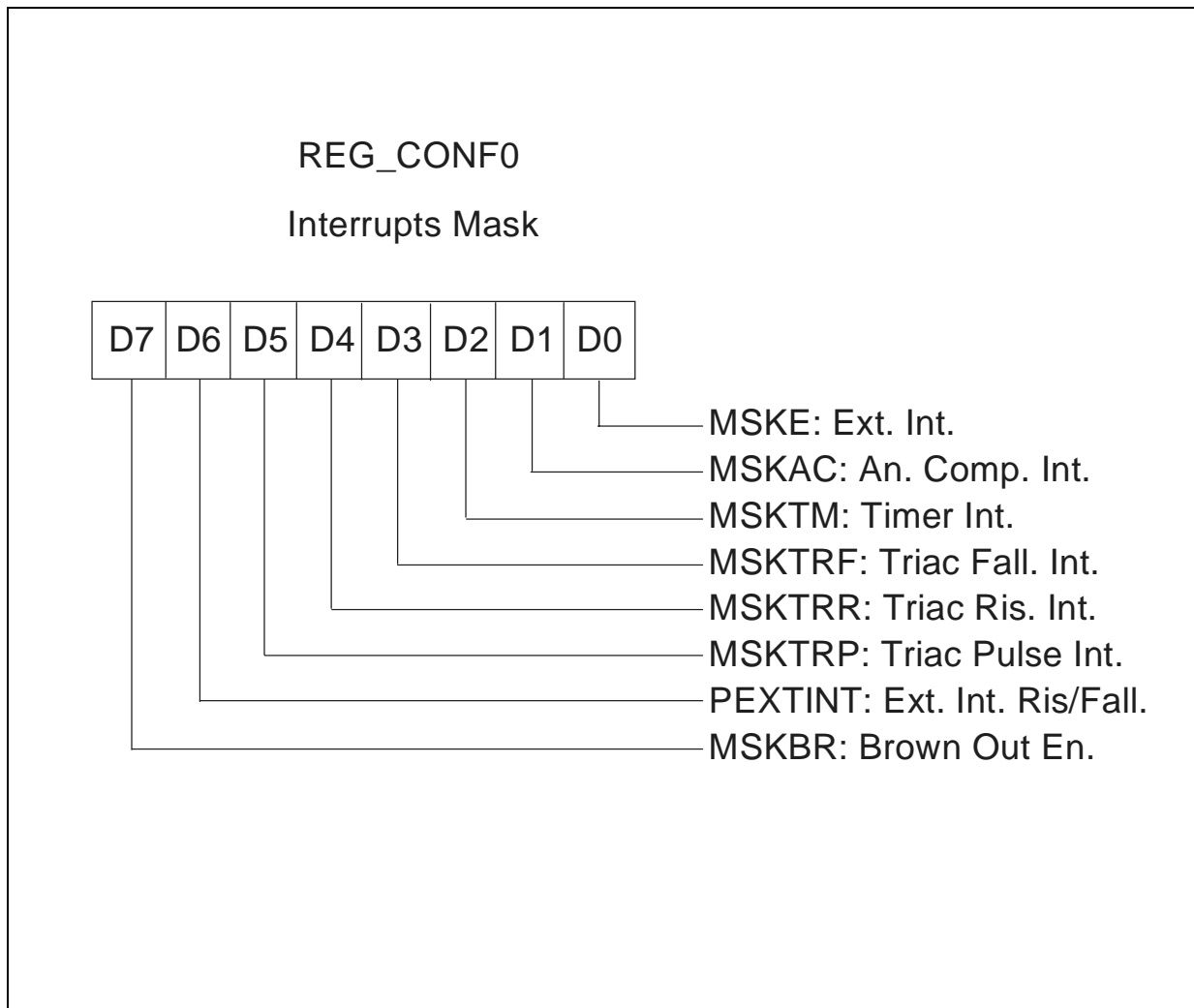
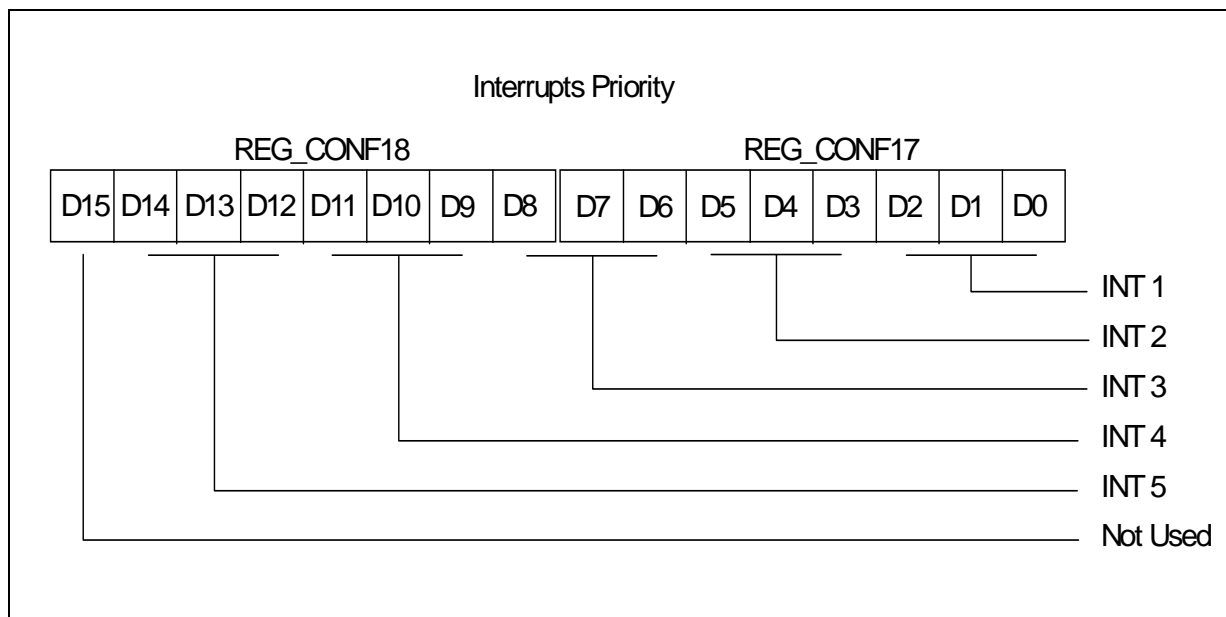

Figure 4.5 Interrupt Configuration Registers 17 and 18



4.5 Interrupt Priority

Seven priority levels are available: level 6 has the lowest priority, level 0 has the highest priority.

Level 6 is associated to the Main Program, levels 5 to 1 are programmable by means of the priority registers called REG_CONF17 and REG_CONF18; whereas the higher level is related to the External Interrupt (INT_EXT).

PWM/Timer, TRIAC/PWM and Analog Block are identified by a three-bit Peripheral Code (see Table 4.2); in order to set the *i*-th priority level the user must write the peripheral label *i* in the related INT_{*i*} priority level.

For instance:

```
LDRC 10,193 (loads the value 193='11000001' in the RAM Register 10)
```

```
LDRC 11,168 (loads the value 168='10101000' in the RAM Register 11)
```

```
LDCR 17,10 (REG_CONF17='11000001')
```

```
LDCR 18,11 (REG_CONF18='10101000')
```

thus defining the following priority levels:

- Level 1: INT_PWM/TIMER (PWM/TIMER Code: 001)
- Level 2: INT_ADC (ADC Code: 000)
- Level 3: INT_TRIAC/PWM_R (TRIAC/PWM Code: 011)
- Level 4: INT_TRIAC/Ph (TRIAC/Ph Code: 100)

- Level 5: INT_TRIAC/PWM_F (TRIAC/PWM_F Code: 010)

Table 4.3 Conf. Registers 17-18 Description

Bit	Name	Value	Level
0, 1, 2	INT1	Peripheral	High
3, 4, 5	INT2	Peripheral	MediumHigh
6, 7, 8	INT4	Peripheral	MediumLow
9, 10, 11	INT5	Peripheral	Low
12, 13,	INT6	Peripheral	Very Low

REMARK: The Interrupt priority must be set at the beginning of the main program, because at the RESET REG_CONF1='00000000', this condition could generate wrong operations. Further, changing the priority levels must be avoided in interrupt service routines.

When a source provides an Interrupt request, and the request processing is also enabled, the CU changes the normal sequential flow of a program by transferring program control to a selected service routine.

When an interrupt occurs the CU executes a JUMP instruction to the address loaded in the related location of the Interrupt Vector and the flags are saved.

When the execution returns to the original pro-

gram, the flags are restored and the program continues from the instruction immediately following the interrupted instruction.

4.6 Interrupts and Low power mode

All interrupts allow the processor to leave WAIT mode. Only an External Interrupt request allows the processor to leave HALT mode: if the interrupt is masked, the related interrupt routine is not serviced and the program continues from the first instruction after the HALT instruction.

4.7 Interrupt RESET

When an interrupt request is sent but the interrupt is masked, it isn't serviced and remains pending, so that when the interrupt is enabled it is serviced immediately. In order to avoid this from happening, the pending interrupt request can be reset with the instruction `RINT j`, which resets the interrupt *j*-th where *j* identify the peripherals as described in the following table (see Table 4.4).

The assembler instruction:

`RINT 2`
Resets the TRIAC/PWM_F interrupt.

WARNING: *If an interrupt is reset, with the RINT instruction within its own interrupt routine, the priority level of the interrupt becomes the lowest and the routine can be immediately interrupted by a lower priority interrupt request.*

Table 4.4 RINT Instruction Code

Peripheral Name	Value
Analog Comparator (*)	0
PWM/TIMER	1
TRIAC/F	2
INT_TRIAC/R	3
INT_TRIAC/P	4
External Interrupt	5

(*) *Not Used in ST52x400 devices*

Figure 4.6 Example of a sequence of Interrupt Requests

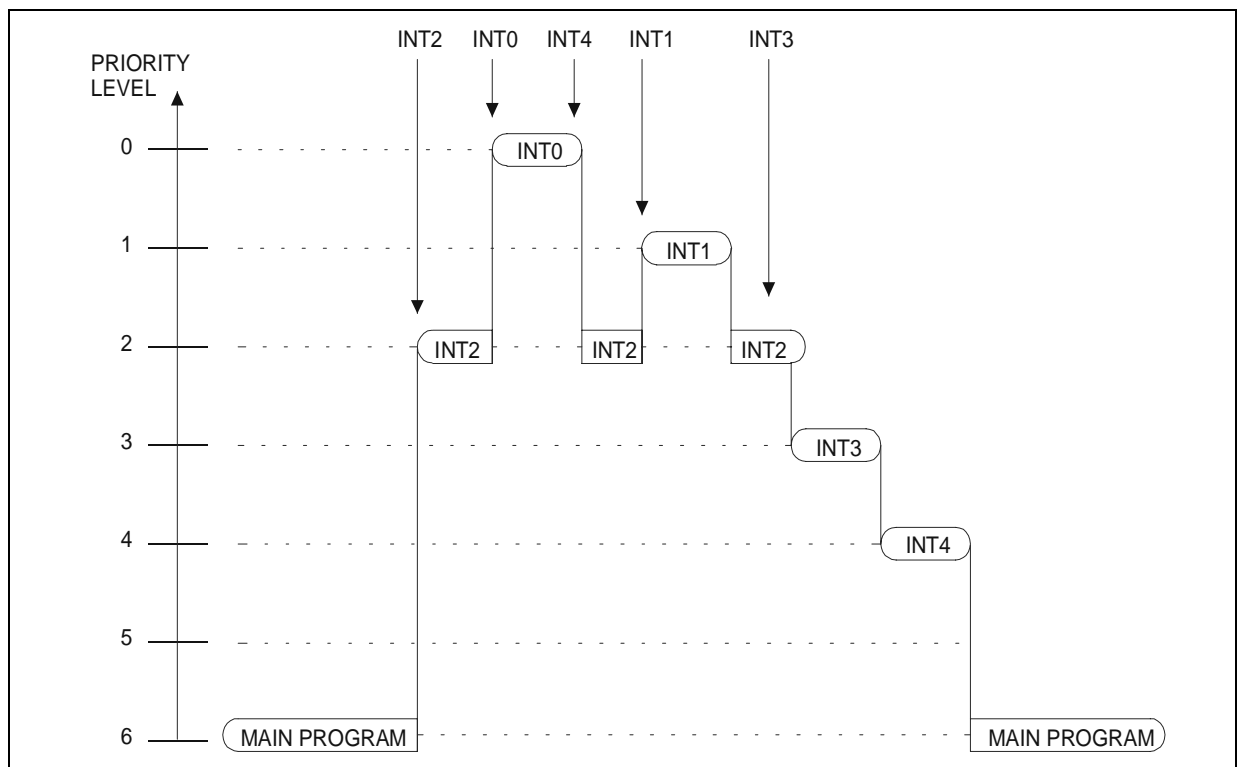

5 CLOCK, RESET & POWER SAVING MODE

5.1 Clock System

The ST52x400/440/441 Clock Generator module generates the internal clock for the internal Control Unit, ALU and on-chip peripherals and is designed to require a minimum of external components.

The ST52x400/440/441 oscillator circuit generates an internal clock signal with the same period and phase as at the OSCin input pin. The maximum frequency allowed is **20 MHz**.

The system clock may be generated by using either a quartz crystal, ceramic resonator (CER-ALOC), or an external clock.

The different clock generator options connection methods are illustrated in Oscillator Connections. When an external clock is used, it must be connected to the pin OSCin while OSCout should be left floating.

The crystal oscillator start-up time is a function of many variables: crystal parameters (especially R_s), oscillator load capacitance (CL), IC parameters, environment temperature, supply voltage.

It must be observed that the crystal or ceramic lead and circuit connections must be as short as possible. Typical values for CL1, CL2 are 10pF for a 20 MHz crystal.

Figure 5.1 Oscillator Connections

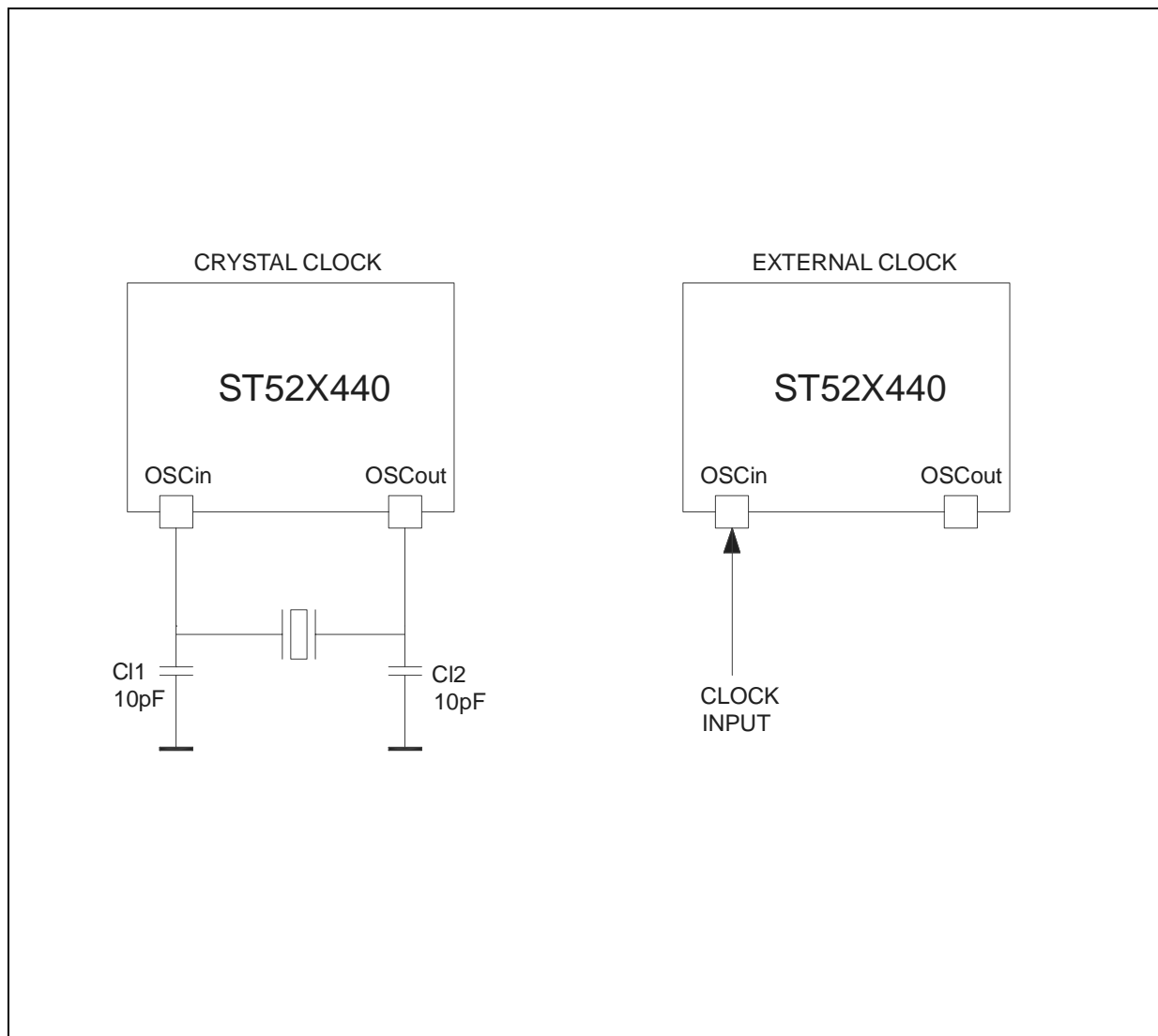

5.2 Reset

There are four sources of Reset:

- RESET pin (external source)
- WATCHDOG (internal source)
- POWER ON Reset (Internal source)
- BROWN OUT Reset (Internal source)

When a Reset event happens, all the registers are set to the reset value and the user program restarts from the beginning.

5.2.1 External Reset.

The Reset pin is an input pin. An internal reset does not affect this pin.

A Reset signal originated by external sources is recognized instantaneously. The RESET pin may be used to ensure Vdd has risen to a point where the MCU can operate correctly before the user program is run. In working mode the Reset must be set to '1' (see Table 1.1)

5.2.2 Reset Operation.

The duration of a RESET condition is fixed at 1.000.000 internal CPU clock cycles (or 4096 in case of BOD).

Following a Power-On Reset event, or after exiting Halt Mode, a 1.000.000 CPU clock cycle delay period is initiated in order to allow the oscillator to stabilize and to ensure that recovery has taken place from the Reset state.

A Pull up resistor of 100 K Ω guarantees that RESET pin is at level "1" when no HALT or Power-On events occurred.

If an external resistor is connected to the RESET pin a minimum value of 10K Ω must be used.

After a RESET procedure is completed, the core reads the instruction stored in the first 3 bytes of the EPROM, which contains a JUMP instruction to the EPROM address containing the first instruction of the user program. The Assembler tool automatically generates this Jump instruction with the first instruction address.

5.2.3 Power-on Reset (POR).

A Power-On Reset is generated by an on-chip detection circuit. This circuit ensures that the device is not started until Vdd has reached the nominal level of 2.3V and allows the clock oscillator to stabilize.

Once 2.3V are reached, the Power-On circuit generates an internal RST signal that releases the internal reset to the CPU and invokes a delay counter of 1.000.000 CPU clock cycles, during which the device is kept in RESET after Vdd has risen.

A correct operation of Power-on detector is guaranteed if the slew rate of Vdd is 0.05 V/ms.

Note: The power supply must fall below 0 V for the internal POR circuit to detect the next rise of Vdd.

At power on the POR is enabled by default.

POR is designed exclusively to cope with power-up conditions and should not be used to detect a drop in the power supply voltage, for which the Brown-out Detector can be used instead.

Figure 5.2 Reset Block Diagram

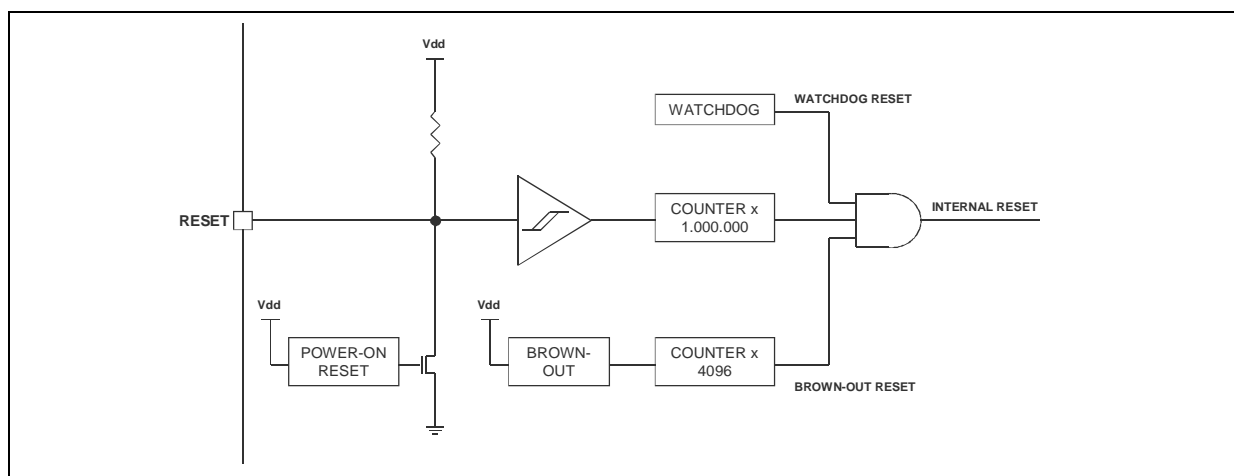

5.2.4 Brown-Out Detector (BOD).

The on-chip Brown-Out Detector circuit prevents the processor from falling into an unpredictable state if the power supply drops below a certain level.

When Vdd drops below the Brown-out detection level, the Brown-out causes an internal processor reset RST that remains active as long as Vdd remains below the Brown-Out Trigger Level.

Brown-Out resets the entire device except the Power-on Detector and the Brown-out itself.

Enabling/disabling the Brown-out detector can be performed by setting the software of the control bit BOD of REG_CONF0 (Table 4.1).

When Vdd increases above the Trigger Level, the Brown-Out reset is turned off after a delay of 4096 CPU clock cycles, which ensures stabilization of the oscillator.

The Brown-Out falling voltage level typical value is 3.8V and the corresponding rising voltage activation level is 4.1V.

A minimum hysteresis of 250mV for the trigger is guaranteed for spike free brown-out detection.

Brown-Out circuit detects a drop if Vdd voltage stays below the safe threshold for longer than 100 Clock cycles before activation/deactivation of the Brown-Out in order to filter voltage spikes.

Brown-Out function is disabled by default and is not active when in HALT mode.

Remark: for higher frequencies, the device needs Supply Voltage higher than the BOD threshold. For this reason the BOD cannot work in this range of frequencies. See Electrical Characteristic Chapter in this Datasheet.

5.3 Power Saving Modes

There are two Power Saving modes: WAIT and HALT mode. These conditions may be entered by using the WAIT and HALT instructions.

5.3.1 Wait Mode.

Wait mode places the MCU in a low power consumption by stopping the CPU. All peripherals and the watchdog remain active. During WAIT mode, the Interrupts are enabled. The MCU will remain in Wait mode until an Interrupt or a RESET occurs, whereupon the Program jumps to the interrupt service routine or, if a RESET occurs, at the beginning of the user program.

Remark: in Wait mode the CPU clock does't stop.

5.3.2 Halt Mode.

Halt mode is the MCU's lowest power consumption mode, which is entered by executing the HALT instruction. The internal oscillator is turned off, causing all internal processing to be stopped, including the operations of the on-chip peripherals.

Halt mode cannot be used when the watchdog is enabled. If the HALT instruction is executed while the watchdog system is enabled, it will be skipped without modifying the normal CPU operations.

The ICU can exit Halt mode after an external interrupt or reset. The oscillator is then turned on and stabilization time is provided before restarting CPU operations. Stabilization time is 4096 CPU clock cycles after the interrupt and 1.000.000 after the Reset.

After the start up delay, the CPU restarts operations by serving the external interrupt routine. Reset makes the ICU exit from HALT mode and restart, after the delay, from the beginning of the user program after the delay.

Warning: if the External Interrupt is disabled, the ICU exits from the Halt mode and jumps to the lower priority interrupt routine.

Figure 5.3 WAIT Flow Chart

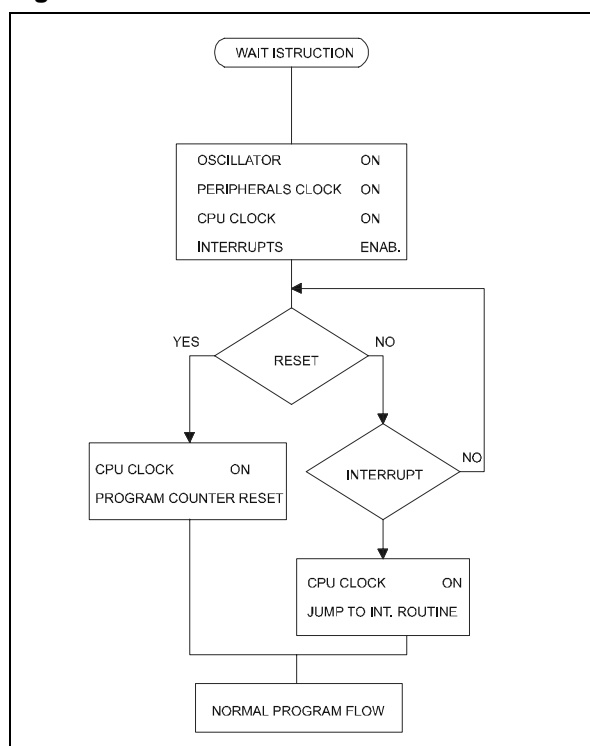
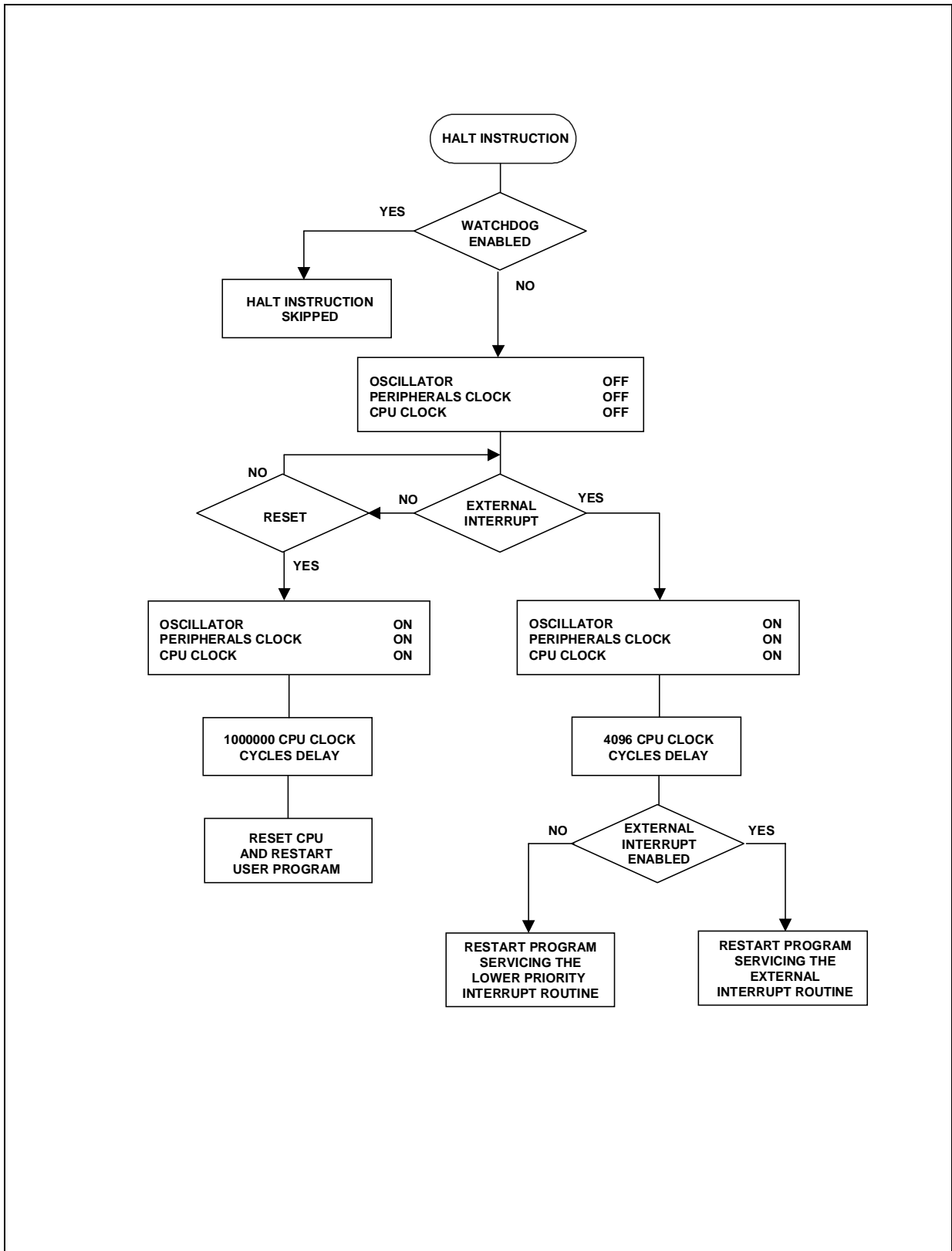

Figure 5.4 HALT Flow Chart



6 I/O PORTS

6.1 Introduction

ST52x400/440/441 devices offer flexible individually programmable multi-functional input/output lines. Refer to Chapter 1 for specific pin allocations.

21 I/O lines, grouped in 3 different ports, are available for **ST52x400G/440G/441G** devices:

PORT A = 8-bit ports (PA0 - PA7 pins)

PORT B = 8-bit ports (PB0 - PB7 pins)

PORT C = 5-bit port (PC0 - PC4 pins)

13 I/O lines, grouped in 2 different ports are available for **ST52x400F/440F/441F** devices:

PORT A = 8-bit ports (PA0 - PA7 pins)

PORT B = 5-bit ports (PB0 - PB3 and PB7 pins)

These I/O lines can be programmed to provide Digital Input/Output or Analog Input, or to connect input/output signals to the on-chip peripherals as Alternate Pin Functions.

The input buffers are TTL compatible with Schmitt Trigger in ports A and C while port B is CMOS compatible without Schmitt trigger and it is used for the Analog Inputs.

The output buffer can supply up to 8 mA.

All the port pins of 400/440 devices have an

internal pull-up resistor (22 kΩ). The 441 device doesn't have internal pull-up resistor. This pull-up resistor is automatically excluded when the pin is configured as Analog Input or, in MAIN1 and MAIN2 pins, when the Triac Driver is configured in Phase Angle Partialization or Burst mode.

Each single port pin can be programmed in input or output or Alternate Function, so that in the same port there can be both input and output pins. The port pins are write/read in parallel at the same time: when reading output pins, the port buffer contents are read; when writing an input pin the value is written in the buffer.

Each port is configured by using Configuration Registers indicated in Table 6.1. The first is used to define if a pin is an Input or an Output, the second defines the Alternate functions.

Table 6.1 I/O Port Configuration Register

PORT A	PORT B	PORT C (*)
Reg_Conf 4	Reg_Conf 13	Reg_Conf 11
Reg_Conf 12	Reg_Conf 14	
	Reg_Conf 11**	

(*) Not available in ST52x400F/440F/441F

(**) Only in ST52x440F/441F

Figure 6.1 Ports A and C Functional Blocks

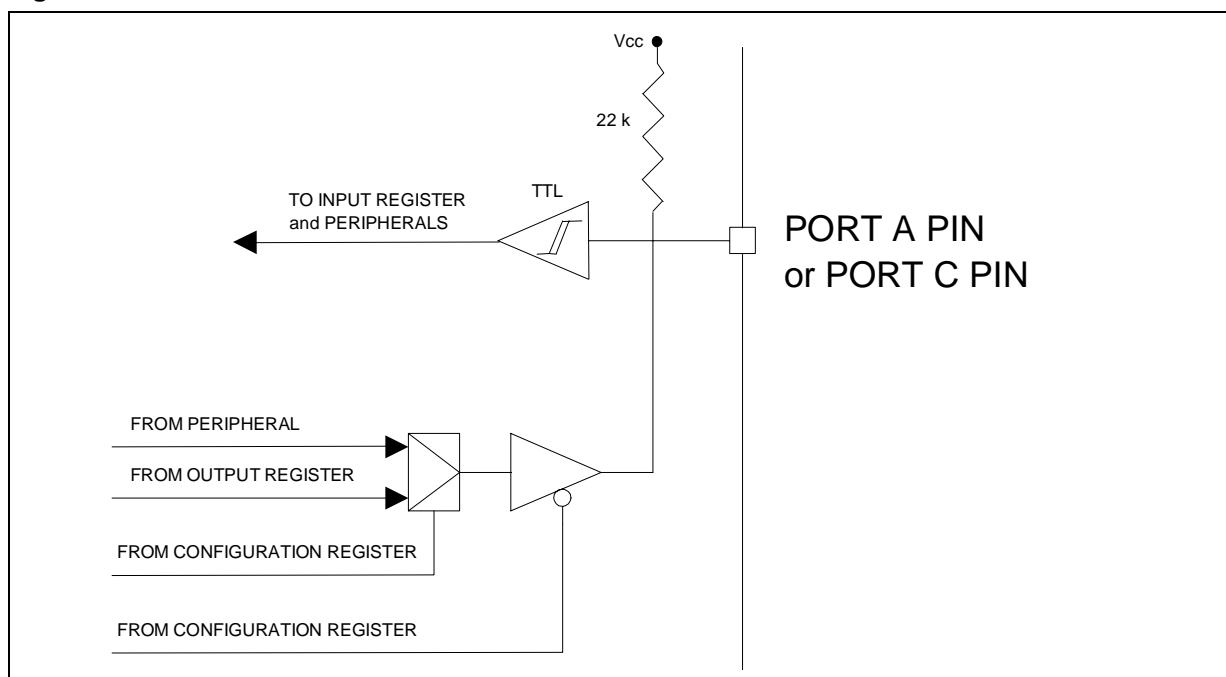
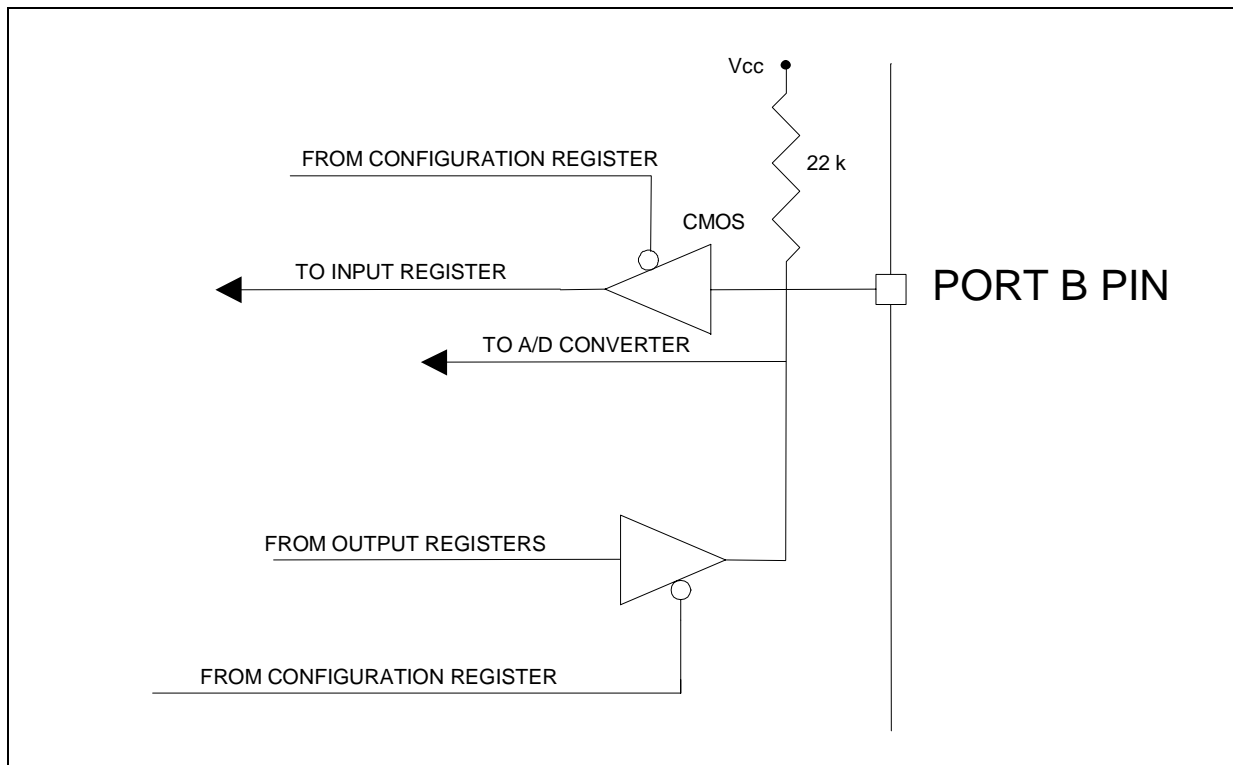

Figure 6.2 Port B Functional Blocks



6.2 Input Mode

The input configuration is selected setting the corresponding configuration register bit in REG_CONF4, REG_CONF13 and, where applicable, REG_CONF11 (see Paragraph I/O Port Configuration Registers) to "1". To use Port A and B pins as digital input, the corresponding bits in REG_CONF12 and REG_CONF14 must be set according to the values shown in Table 6.4, Table 6.5 and Table 6.6.

Table 6.2 Input Register and I/O Ports

PORT A	PORT B	PORT C (*)
IR 14	IR 15	IR 16

(*) Not used for ST52x400F/440F/441F

Table 6.3 Output Register and I/O Ports

PORT A	PORT B	PORT C (*)
OR 0	OR 1	OR 2

(*) Not used for ST52x400F/440F/441F

Digital input data is automatically stored in

the Input Registers (see Table 6.2), but the single bit of the Input Register (IR) cannot be read directly and the value in a RAM location must be copied. Digital data is stored in a RAM location by using the assembler instruction:

```
LDRI regx, inpy
```

Then, each single bit can be examined by using AND and OR operators with a suited mask value.

6.3 Output Mode

The output pin configuration is selected by setting the corresponding configuration register bit to "0" (REG_CONF4, REG_CONF13 and, where applicable, REG_CONF11) (see paragraph I/O Port Configuration Registers). In order to use Port A and B pins as digital output, the corresponding bits in REG_CONF12 and REG_CONF14 must be set according to the values illustrated in Tables - Port A - REG_CONF 4, - Port A - REG_CONF 12 and Analog Inputs REG_CONF 14.

Digital data is transferred to the related I/O Port by means of the Output register (see Table 6.3), by using the assembler instructions LDPE or LDPR that respectively take the value to be transferred to the ports from EPROM and RAM.

6.4 Alternate Functions.

Port A and B pins in ST52x400/440/441 are configurable to be used with different functions (Alternate Functions) related to the use of peripherals.

To configure a pin in Alternate Function the related configuration registers must be set according to the values shown in Tables - Port A - REG_CONF 4, - Port A - REG_CONF 12 and Analog Inputs REG_CONF 14.

For example: if pin PA5/TCLK has to be used as an external PWM/Timer Clock, REG_CONF4[(5)] bit must be set to '1'.

When the signal is an input of an on-chip peripheral, the related I/O pin has to be configured in Input Mode.

When a pin of Port B is used as an Analog Input, the related I/O pin is automatically set in triestate. The analog multiplexer (controlled by the Analog Comparator Configuration Register) switches the analog voltage present on the selected pin to the common analog rail, which is connected to the ADC input.

It is recommended that the voltage level or loading on any port pin not be changed while conversion is running. Furthermore, it is recommended not to have clocking pins located close to a selected analog pin.

6.5 I/O Port Configuration Registers

The I/O mode for each bit of the three ports are selected by using Configuration Registers 4, 12, 13 and 11 (Table 6.1). The structure of these registers is illustrated in tables - Port A - REG_CONF 4, - Port A - REG_CONF 12, - Port B - REG_CONF 13, Analog Inputs REG_CONF 14 and - Port C - REG_CONF 11. Each bit of the configuration registers sets the I/O mode of the related port pin.

Analog Comparator Inputs

Pins PB0-PB7 for ST52x440G/441G and PB0-PB3 and PB7 in ST52x440F/441F can be configured to be Analog Inputs by setting the related bit in REG_CONF 14 to "1" (Table 6.7) and the related bit in REG_CONF13 to "1" (Table 6.6). These analog inputs are connected to the on chip Analog Comparator.

If the BandGap Reference (BG) is needed as an Output for ST52x440G/441G REG_CONF13[6] must be set to "0" and REG_CONF14[6] to "1".

Timer/PWM Alternate Functions

Pins of Port A can be configured to be I/Os of the on-chip TIMER/PWM of ST52x400/440/441. The configuration of these pins is performed by using Configuration Registers REG_CONF4 and REG_CONF12 (Tables - Port A - REG_CONF 4 and - Port A - REG_CONF 12).

If a pin has to be a TIMER Input (TSTRT, TCLK, TRES) the related bit of REG_CONF4 must be set to "1" and of REG_CONF12 must be set to "1".

If, instead it must be a TIMER Output (TOUT, TOUTN), REG_CONF12 related bit must be set to "0" and the related bit of REG_CONF4 be set to "0".

TRIAC Driver Alternate Function

When using the on-chip TRIAC, to have the TRIAC Output on pin PA0, bit REG_CONF12[0] must be set to "0" and REG_CONF4[0] to "0".

When a synchronization with the Mains voltage is necessary, in case either the Phase Angle Partialization or the Burst Modes is chosen, to have MAIN1 and MAIN2 as Inputs on PortA, it is necessary to set bits 1 and 2 of REG_CONF4 to "1".

Table 6.4 - Port A - REG_CONF 4

Bit	Name	Value	Pin Description
0	D0	X	PA0
1	D1	X	PA1/MAIN1
2	D2	X	PA2/MAIN2
3	D3	X	PA3/ACSTRT(*)
4	D4	X	PA4/TSTRT
5	D5	X	PA5/TCLK
6	D6	X	PA6/TRES
7	D7	X	PA7/INT
X = 0 Pin set as Digital Output X = 1 Pin set as Alternate Function Input			
Reset Configuration '1111'			

(*) Not available in ST52x400xx

Table 6.5 - Port A - REG_CONF 12

Bit	Name	Value	Pin Description
0	D0	X	PA0/TROUT
1	D1	X	PA6/TOUT
2	D2	X	PA2/TOUTN
3	D3	X	PA7/ACSYNC(*)
4	D4		not used
5	D5		not used
6	D6		not used
7	D7		not used
X = 0 Pin set as Alternate Function Output X = 1 Pin set as Digital I/O			
Reset Configuration '1111'			

(*) Not available in ST52x400xx

Table 6.7 Analog Inputs REG_CONF 14

Bit	Name	Value	Pin Description
0	D0	X	PB0/AC0(*)
1	D1	X	PB1/AC1(*)
2	D2	X	PB2/AC2(*)
3	D3	X	PB3/AC3(*)
4	D4	X	PB4/AC4(*)(**)
5	D5	X	PB5/AC5(*)(**)
6	D6	X	PB6/BG(*)(**)
7	D7	X	PB7/CS(*)(**)
X = 0 Pin set as Digital I/O X = 1 Pin set as Analog Input			
Reset Configuration '00000000'			

(*) Not available in ST52x400xx

(**) Not available in ST52x440F/441F

Table 6.6 - Port B - REG_CONF 13

Bit	Name	Value	Related Pin
0	D0	X	PB0
1	D1	X	PB1
2	D2	X	PB2
3	D3	X	PB3
4	D4	X	PB4(*)
5	D5	X	PB5(*)
6	D6	X	PB6(*)
7	D7	X	PB7
X = 0 Pin set as Output X = 1 Pin set as Input			
Reset Configuration '11111111'			

(*) Not available in ST52x400F/440F/441F

Table 6.8 - Port C - REG_CONF 11

Bit	Name	Value	Related Pin
0	D0	X	PC0 ^(*)
1	D1	X	PC1 ^(*)
2	D2	X	PC2 ^(*)
3	D3	X	PC3 ^(*)
4	D4	X	PC4 ^(*)
5	D5	1	(**)
6	D6		not used
7	D7		not used
X = 0 Pin set as Digital Output X = 1 Pin set as Digital Input			
Reset Configuration '11111111'			

^(*) Not used in ST52x400F/440F/441F

^(**) Must be set to 1

7 ANALOG COMPARATOR (ST52X440/441)

7.1 Analog Module Overview

The ST52x440/441 includes an Analog Comparator (AC) among its peripherals.

The Analog Comparator is endowed with analog and digital elements in order to also allow the user to make use of it as a single slope Analog to Digital converter. In particular, ST52x440/441 is endowed with:

- Analog Comparator;
- 7 channels analog mux (6 external lines, 1 internal voltage reference);
- a current source providing 7 programmable values;
- 16 bit Timer with a Capture Register and 12 bit Prescaler;

The Analog Comparator peripheral can also be used as a single slope A/D, supplying a ramp signal to the pin CS. The selection of the working mode, as either Analog Comparator or single slope A/D can be performed via the REG_CONF3[(0)] bit.

7.2 Comparator Mode

In Analog Comparator mode, REG_CONF3[(0)] is set to "0". The AC inputs are available on the external pins. The reference signal must be connected to the CS pin, the signal to be compared goes to the analog input AC0.

When the input becomes lower than the reference, the Analog Comparator output changes to value "1". The output can be read on the less significant bit of Input Register 1 AC_CHAN0H (Table 2.1).

7.3 A/D Converter Mode

To use the Analog Comparator for A/D Conversion, REG_CONF3[(0)] bit must be set to "1".

In A/D Mode either the insertion of an external capacitor to pin CS or the connection to an external signal to generate the reference ramp may be chosen.

In the first case REG_CONF16[(1)] bit must be set to "0". The internal current generator, utilized to charge the capacitor, provides 7 possible current values, which can be selected via REG_CONF3[(7:5)]. The current values are in the range between 0 to 70µA with step of 10µA.

The capacitor should have a low voltage coeffi-

Figure 7.1 Analog Peripheral Block Diagram

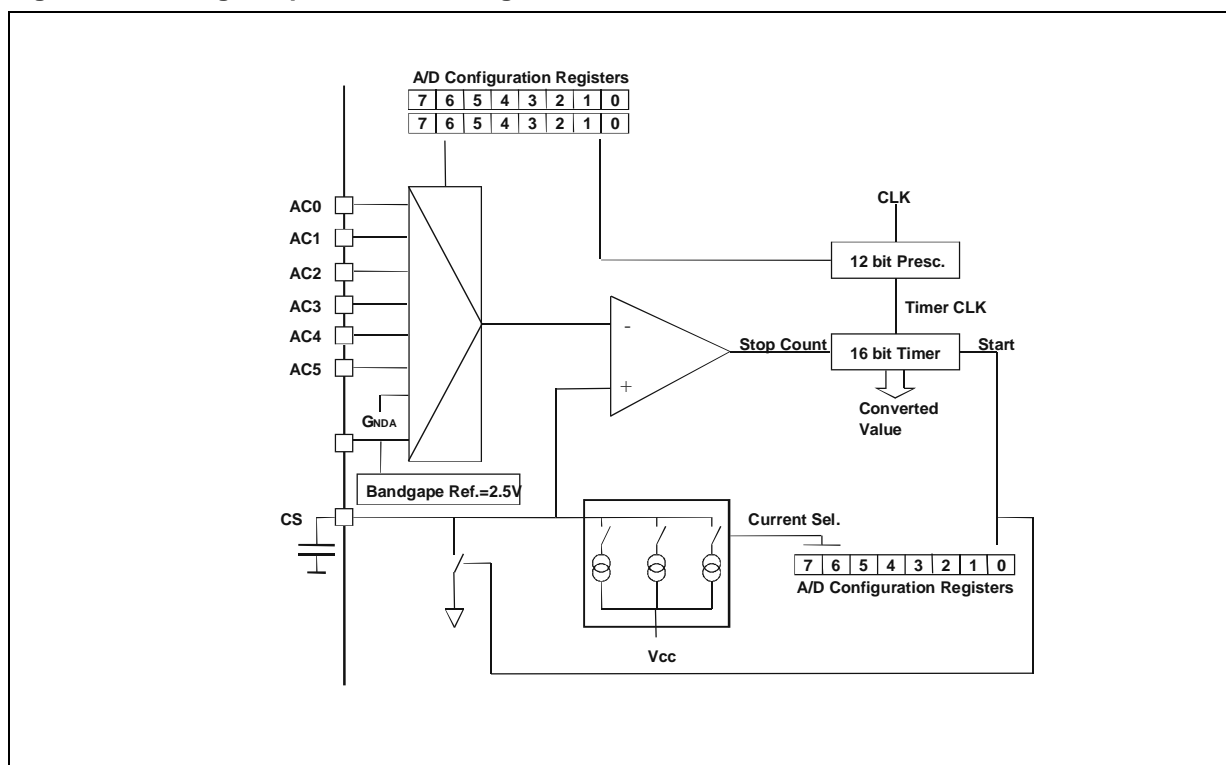

cient for optimum results (recommended capacitance values range is 10-1000 nF). The optimum linearity in conversion can be obtained if the voltage level on the selected input channel does not exceed a maximum of 3 V. In the second case, if an external ramp generator is used, the REG_CONF16[(1)] bit must be set to "1".

The 16 bit Timer, directly triggered by the output of the Analog Comparator, allows the measurement of the conversion time that is proportional to the analog value.

The device clock is divided by an internal 12 bit Prescaler to generate the appropriate Timer clock that allows the desired resolution to be obtained with a reasonable conversion time.

When an appropriate value of the capacitor is selected, the conversion should be complete before the full count is reached. A timer overflow flag is set once the Timer reaches its maximum count value.

Generally, the maximum conversion time of the A/D converter depends on the capacitor chosen and the charge current. The maximum conversion time can be calculated by using the following formula:

$$\text{ConversionTime}(ms) = \frac{C(nF) \times \text{FullScale}(V)}{\text{ChargeCurrent}(uA)}$$

C is the capacitance in nF, FullScale is the maximum voltage recommended for the input signal, which is 3 V, and ChargeCurrent is the configured value of the current for charging the capacitor.

To obtain the desired resolution, the prescaler value has to be set in accordance to the following formula:

$$P = \frac{C(nF) \times CKM(MHz) \times \text{FullScale}(V) \times 10^3}{\text{ChargeCurrent}(uA) \times 2^{\text{RESOLUTION}}} - 1$$

CMK indicates the Master Clock frequency and Resolution is the number of bits that should contain the converted values. Recommended values for the resolution are in the range between 8-14 bits.

After the Capacitor is charged, it is discharged in a number of clock cycles equivalent to (P+1) x 410. When the external ramp generator is used, a rising ramp or a falling ramp may be chosen. In this case, the timer counter should be specified to be either an up counter (REG_CONF3[(3)]=0) or a down counter (REG_CONF3[(3)]=1).

By using a rising ramp the Analog Comparator

must be configured to trigger the signal when it crosses the compared value from low to high (REG_CONF3[(2)]=0); vice versa, using a falling ramp, the polarity should be set to trigger the signal in crossing from high to low (REG_CONF3[(2)]=1).

When the Capacitor is used, it generates a rising ramp. For this reason the polarity must be configured to trigger the crossing from low to high (REG_CONF3[(2)]=0).

In order to synchronize the external ramp signal and the timer, the ACSTRT and ACSYNC pin have to be used. The input pin ACSTRT is used to start the timer when the external ramp is started (ACSTRT=1). The ACSYNC output pin provides the handshake signal, which (when ACSYNC=1) furnishes information indicating that the timer is ready to receive the start signal.

If the input signal is too high, the counter may overflow. When this happens, bit 0 of the Input Register 13 AC_STATUS (Table 2.1) is set to 1 and an interrupt is generated at the end of count. If the counter is configured in down counting, the bit is set when the counter goes in underflow.

7.3.1 Operating Modes.

In order to avoid the errors introduced by the A/D components drift, a periodic conversion of the internal reference signals can be performed in order to calibrate the converted values. Two different internal voltage references are available:

- 1) Bandgap voltage, this reference voltage can also be used externally for analog signal conditioning.
- 2) GNDA.

Setting the REG_CONF1[(0)] to "1" the peripheral converts the reference signal after converting each analog signal. In order to choose the reference, REG_CONF3[(1)] should be configured.

To ensure secure and stable measurements, several measurements on the same channel and mediating the obtained results are recommended. The conversion of each single channel may be repeated up to three times by configuring the REG_CONF1[(7:6)].

The analog multiplexer allows the user to work in four different modes:

- Single Channel Single Conversion
- Single Channel Multiple Conversions
- Multiple Channels Single Conversion
- Multiple Channels Multiple Conversions

The four modes are selected by configuring REG_CONF1[(2)] to choose among the conversion of a single channel or a sequence of channels and REG_CONF1[(1)] to perform the conversion once or continuously.

REG_CONF1[(5:3)] bits allows the user to choose the channel to be converted in Single Channel mode or the last channel to be converted (starting from AC0) in Multiple Channels mode.

To start the conversion, REG_CONF16[(0)] must be set to “1” and to “0” to stop it.

Note: in Single conversion modes, the Start bit REG_CONF16[(0)] must be reset to 0 before starting another conversion; in Comparator Mode it must be set to “0”.

Table 7.1 Configuration Register 1

Bit	Name	Value	Description
0	REFM	0	Convert only data
		1	Convert data and reference value
1	CONV	0	Single Conversion
		1	Continuous Conversion
2	SEQ	0	Single Channel
		1	Multiple Channel
3-5	CHAN	000	Channel 0 AC0
		001	Channel 1 AC1
		010	Channel 2 AC2
		011	Channel 3 AC3
		100	Channel 4 AC4
		101	Channel 5 AC5
		110	Not used
		111	Not used
6	NBCV	00	One Conversion
		01	Two Conversion
7	NBCV	10	Three Conversion
		11	Not Used

Reset Configuration Value = “00000000”

Table 7.2 Configuration Register 15

Bit	Name	Description
7:0	PRES(7:0)	Timer Prescaler (7:0)

Reset Configuration Value = “00000000”

The Analog Comparator in A/D Converter Mode supplies an interrupt source. The interrupt signal can be generated either after the end of the each channel conversion (REG_CONF3[(4)]=0) or after the end of the conversion sequence (REG_CONF3[(4)]=1).

Table 7.3 Configuration Register 3

Bit	Name	Value	Description
0	MODE	0	Comparator Mode
		1	A/D Mode
1	REFV	0	Reference= GNDA
		1	Reference = 2.42 V
2	POL	0	Rising crossing
		1	Falling crossing
3	UPDW	0	Up Counter
		1	Down Counter
4	INT	0	Interrupt after each conversion
		1	Interrupt after the end of the conversion cycle
5	CUR	000	Current generator off
		001	10 µA charge current
		010	20 µA charge current
		011	30 µA charge current
		100	40 µA charge current
6	CUR	101	50 µA charge current
		110	60 µA charge current
7	CUR	111	70 µA charge current

Reset Configuration Value = “00000000”

Table 7.4 Configuration Register 16

Bit	Name	Value	Description
0	STRT	0	A/D Converter Stopped
		1	A/D Converter Started
1	ADM OD	0	Capacitor ramp
		1	External ramp generator
2	Not used		
3	Not used		
7:4	PRES(11:8)	Timer Prescaler (11:8)	

Reset Configuration Value = “00000000”

Figure 7.2 Configuration Register 1

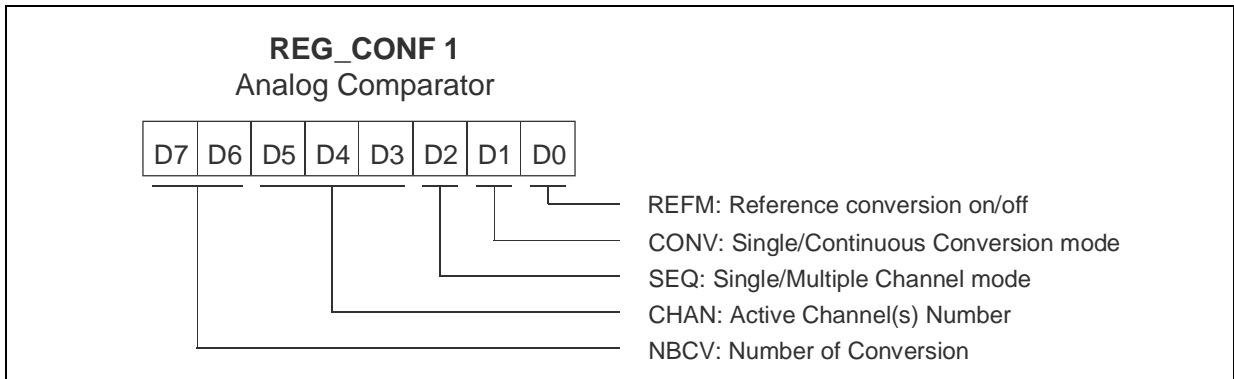

Figure 7.3 Configuration Register 3

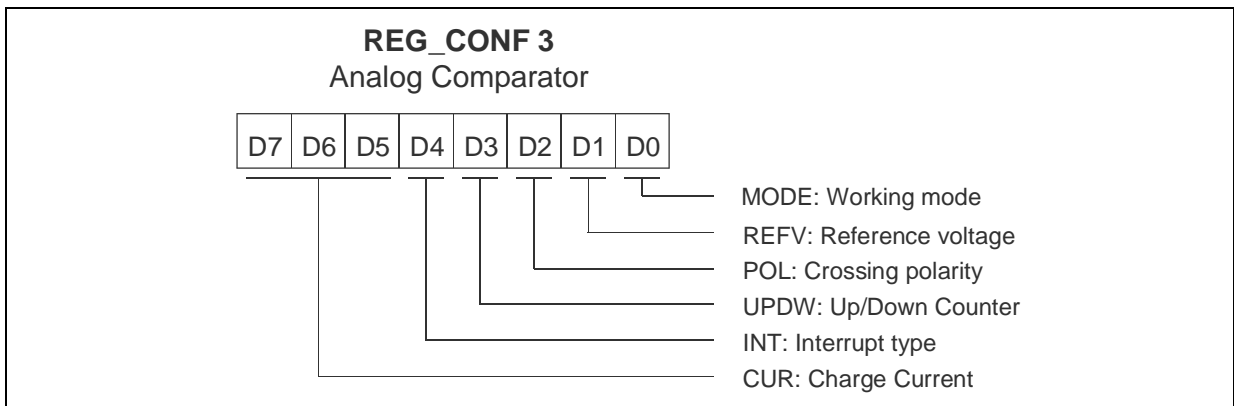

Figure 7.4 Configuration Register 15

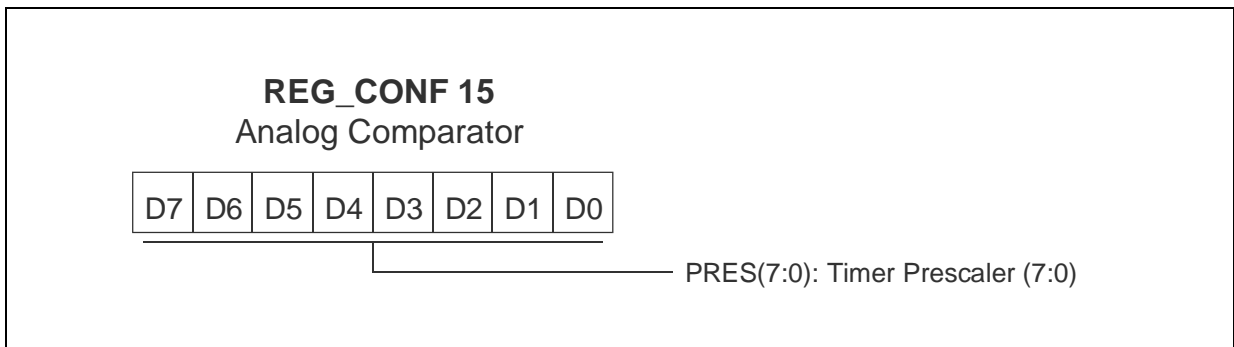
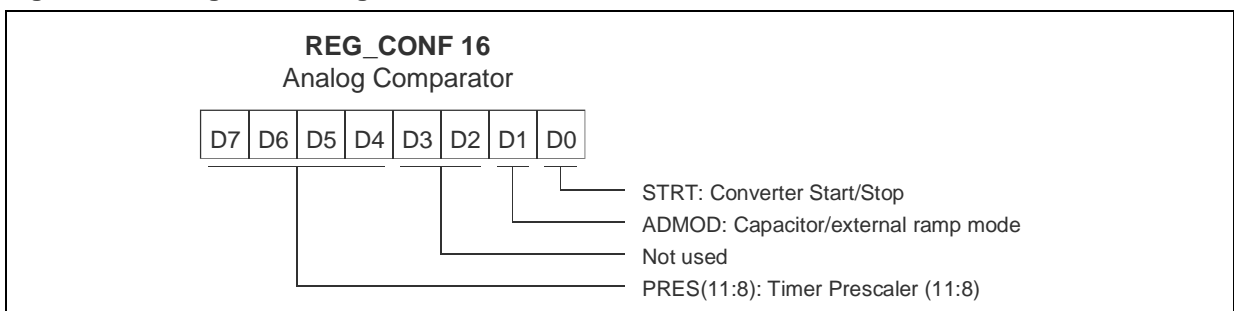

Figure 7.5 Configuration Register 16



8 WATCHDOG TIMER

8.1 Functional Description

The Watchdog Timer (WDT) is used to detect the occurrence of a software fault, usually generated by external interference or by unforeseen logical conditions, which causes the application program to abandon its normal sequence. The WDT circuit generates an MCU reset on expiry of a programmed time period (Timeout), unless the program refreshes the WDT before the end of the programmed time period itself.

16 different time delays can be selected by using the WDT configuration register REG_CONF2 as in Table 8.2.

WDT is activated by the assembler instruction WDTRFR.

At the end of the programmed time delay, WDT starts a reset cycle pulling the reset pin low.

During normal operation, when WDT is active, the application program has to refresh this peripheral at regular intervals to prevent an MCU reset. WDT refresh is performed by the WDTRFR assembler instruction.

To stop WDT during the user program executions instruction WDTSLP has to be used.

WDT working frequency is equal to Master Clock

frequency divided by a fixed Prescaler with a division factor of 500, to obtain WDT CLK signal that is used to fix the WDT Timeout period (Figure 8.1).

Table 8.1 Watchdog Timing range (CLKM=20 MHz)

	WDT Timeout period (ms)
min	0.025
max	234.375

With a Master Clock of 20MHz, for instance, a WDT Timeout period can be defined between 0.025ms and 234.375ms, depending on WDT REG_CONF2 values.

Timeout delay values at different Master Clock frequencies can be calculated as the product of WDT clock number pulses (Table 8.2) by WDT CLK period (Table 8.4).

Warning: changing the REG_CONF2 value when the WDT is active, a WDT reset is generated and the CPU is restarted. To avoid this side effect, use the WDTSLP instruction before changing the REG_CONF2.

Figure 8.1 Watchdog Block Diagram

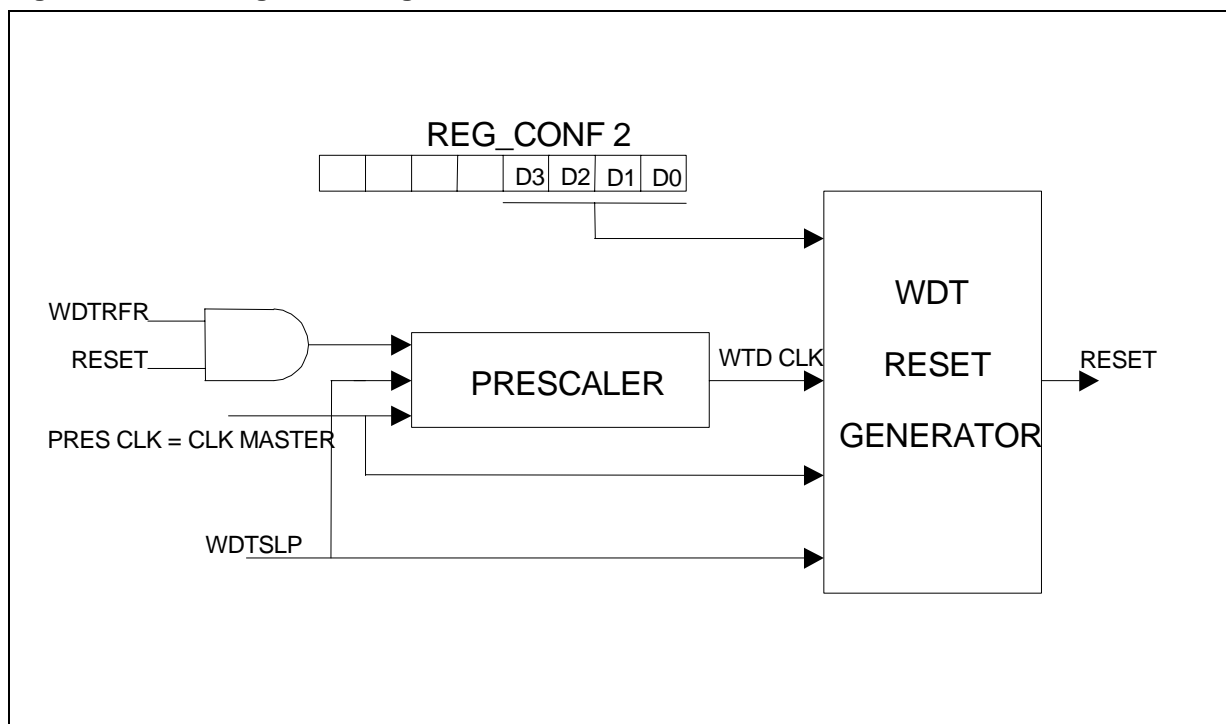

8.2 Register Description

WDT Timeout period can be set by setting the first 4 bits of REG_CONF2: this allows 16 different values of WDT Clock pulse number to be defined. The WDT CLK is derived from the Master Clock divided by 500. Timeout is then obtained by multiplying the WDT CLK period for the number of pulses defined in configuration register REG_CONF2. Table 8.4 illustrates the pulse length for typical values of Master Clock. Table 8.3 illustrates the timeout WDT values when Master Clock is 5 MHz.

Table 8.2 WDT REG_CONF2

Bit	Name	Value	Timeout Values (WDT CLK pulses)
0	D(3:0)	0000	1
		0001	625
		0010	1250
		0011	1875
1		0100	2500
		0101	3125
		0110	3750
		0111	4375
2		1000	5000
		1001	5625
		1010	6250
		1011	6875
3		1100	7500
		1101	8125
		1110	8750
		1111	9375
4-7	NC	x	Not Used
Reset Configuration '0000'			

Table 8.3 Timeout Values with CLKM=5 MHz

Bit	Name	Value	Timeout Values
0	D(3:0)	0000	0.1
		0001	62.5
		0010	125
		0011	187.5
1		0100	250
		0101	312.5
		0110	375
		0111	437.5
2		1000	500
		1001	562.5
		1010	625
		1011	687.5
3		1100	750
		1101	812.5
		1110	875
		1111	937.5
4-7	NC	x	Not Used
Reset Configuration '0000'			

Table 8.4 Typical WDT CLK PERIOD

MASTER CLK (MHz)	WDT CLK (KHz)	WDT CLK PERIOD (ms)
4	8	0.125
5	10	0.1
8	16	0.0625
10	20	0.05
20	40	0.025

9 PWM/TIMER

ST52x400/440/441 on-chip PWM/TIMER peripherals consist of an 8-bit counter with a 16-bit programmable prescaler that provide a maximum count of 2^{24} (Figure 9.1).

The TIMER has two different working modes:

- Timer Mode
- PWM (Pulse Width Modulation) Mode that can be selected by setting register REG_CONF5[7] bit TMODE.

The Timer has an Autoreload Function in PWM Mode. Its output TOUT is available, with its complementary signal TOUTN on external pins by setting PA6 and PA2 bits of REG_CONF4 and REG_CONF12 (see tables - Port A - REG_CONF 4 and - Port A - REG_CONF 12).

The TIMER can also use an external START/STOP signal (Input capture), an external RESET and external CLOCK signals: PA4/TSTRT, PA6/TRES and PA5/TCLK pins. To use TSTRT, TRES, TCLK external signals the related pins PA4, PA6 and PA5 must be configured in Input Mode by setting registers REG_CONF4 and REG_CONF12 (see table - Port A - REG_CONF 4 and - Port A - REG_CONF 12).

The content of the 8-bit counter of the TIMER is incremented on the Rising Edge of the 16-bit prescaler output (PRESCOUT) and it can be read at any instant of the counting phase, which is then saved in a RAM memory location. The PWM/Timer Counter value can be read from the Input Register PWM_COUNT (Input Registers 18, see Table 2.1). The PWM/Timer Status can be read from the Input Register PWM_STATUS (Input Registers 19. See Table 2.1). This register indicates if the TIMER is in START/STOP (bit 1) and in SET/RESET bit(0).

9.1 Timer Mode

Timer Mode is selected by setting the TxMODE bit of REG_CONF5[7].

The TIMER can receive three signals as inputs: Timer Clock (TCLK), Timer Reset (TRES) and Timer Start (TSTRT) (Figure 9.1). Each of these signals can be generated internally or externally by setting TSTR, TRST, TCLK bits of REG_CONF7 register as illustrated in Table 9.3. TMRCLK is the Prescaler output, which increments the Counter value on the rising edge. TMRCLK is obtained from the internal clock signal (CLKM) or from the external signal provided on the PA5/TCLK pin.

NOTE: The external clock signal, applied on TCLK pin, must have a frequency, which is at least two times smaller than the internal master clock.

The prescaler output can be selected by setting PRESC bits of REG_CONF6 register (Table 9.2). TRES resets the content of the TIMER 8-bit counter to zero. It is generated internally by setting the TIRST bit of REG_CONF5 (Table 9.1). TSTRT signal starts and stops the Timer counting only if the peripheral is configured in Timer mode. It is generated internally by setting the TSTR bit of REG_CONF5 (Table 9.1).

TIMER START/STOP can be provided externally from the TSTRT pin (Input Capture). In this case, TSTRT signal allows the ICU to work in two different modes by setting the TESTR configuration bit of REG_CONF5 register.

LEVEL: When the TSTRT signal is high the Timer starts counting. When the TSTRT is low the counting stops and the current value is stored in the PWMCOUNT Input Register.

Figure 9.1 Timer Peripheral Block Diagram

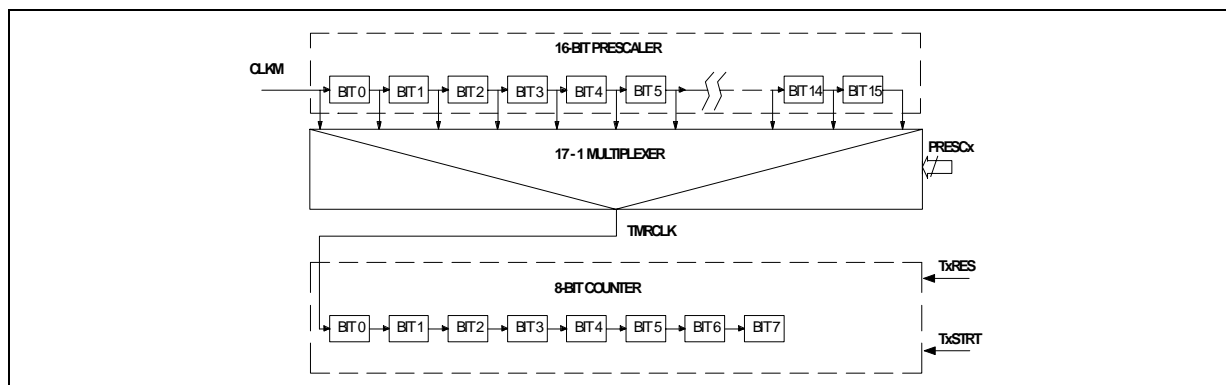
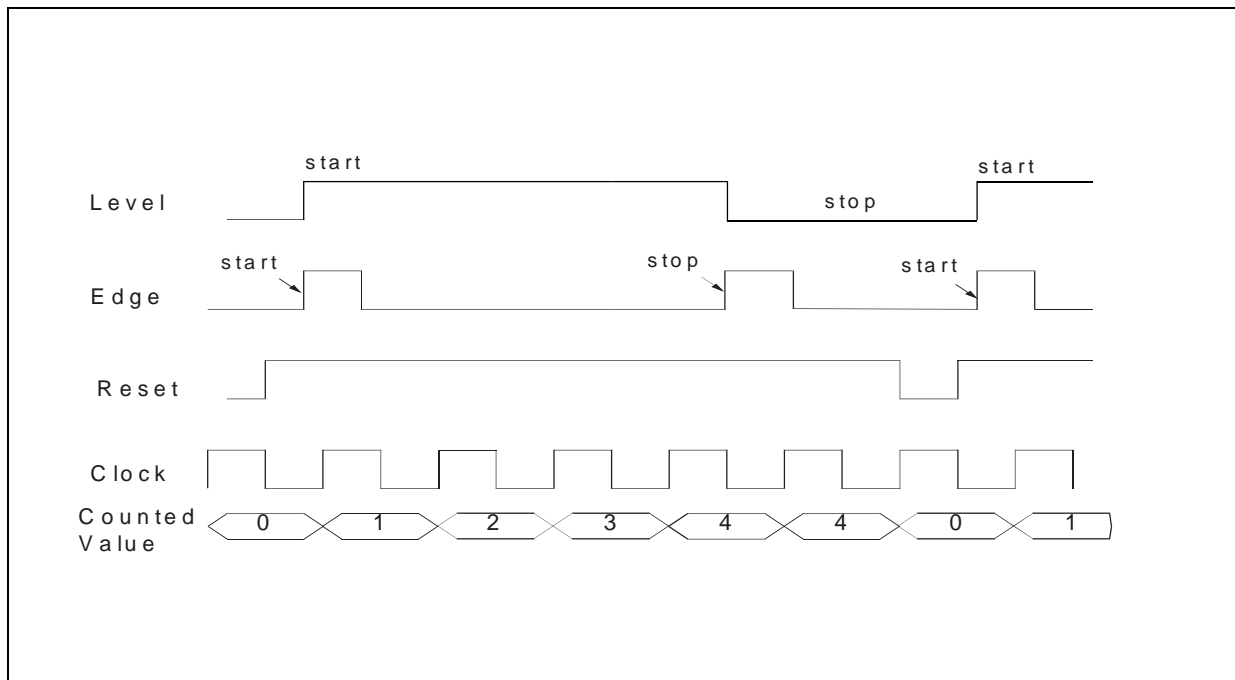

Figure 9.2 Timer 0 External START/STOP Mode



EDGE: After the reset, on the first TSTART rising edge, the TIMER starts counting and, at the next rising edge, it stops. In this manner, the period of an external signal may be measured.

The Timer output signal, TIMEROUT, is a signal with a frequency equal to the 16-bit-Prescaler output signal, TMRCLK, divided by the Output Register PWM_COUNT value (8 bit) (Output Registers 9, Table 2.3), that is the value to count.

TIMEROUT waveform can be of two types:

type 1: TOUT waveform equal to a square wave with a 50% duty-cycle

type 2: TOUT waveform equal to a pulse signal with the pulse duration equal to the Prescaler output signal.

Figure 9.3 TIMEROUT Signal Type

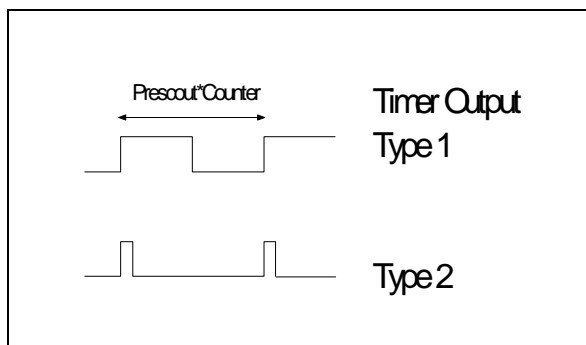

The Timer output signal waveform type can be selected by setting the correspondent TMRW bit of REG_CONF6.

9.2 PWM Mode

PWM working mode is obtained by setting the correspondent TMODE bit of REG_CONF5 to "1".

TIMEROUT, in PWM Mode, consists of a signal, with a fixed period, whose duty cycle can be modified by the user.

TIMEROUT signal is available on TOUT pin and TIMEROUT complementary signal is available on TOUTN pin, setting the relative bits on PORT A, REG_CONF12[1] and REG_CONF12[2], to "0" and REG_CONF4[6] and REG_CONF4[2] to "0".

The PWM TIMEROUT period can be fixed by setting the 16-bit prescaler output and an initial autoreload 8-bit counter value stored in the Output Register PWM_RELOAD, as illustrated in Figure 9.4. The Output Register PWM_RELOAD value is automatically reloaded in the Counter when it restarts counting.

NOTE: the Start/Stop and Set/Reset signals should be moved together in PWM mode. If the Start/Stop bit is reset during the PWM mode working, the TxOUT signal keeps its status until the next start.

Figure 9.4 PWM Mode with Auto Reload

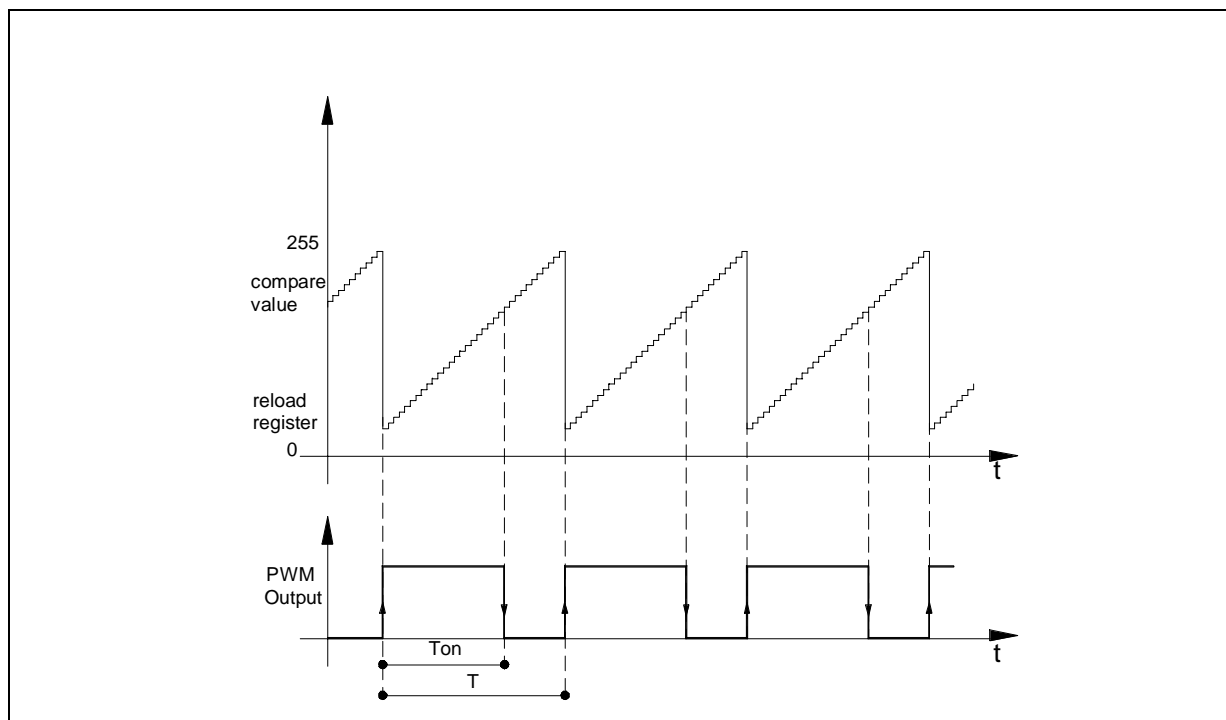

The 16-bit Prescaler divides the master clock, CLKM or the external signal TCLK. The Prescaler output can be selected setting the PRESC bit of REG_CONF6.

NOTE: The external clock signal, applied on TCLK pin, must have a frequency that is at least two times smaller than the internal master clock.

When the Counter reaches the Peripheral Register PWM_COUNT value (Compare Value), the TIMEROULT signal changes from high to low level, up to the next counter start.

The period of the PWM signal is obtained by using the following formula:

$$T = (255 - PWM_RELOAD) * TMRCLK$$

where TMRCLK is the output of the 16-bit prescaler. The duty cycle of the PWM signal is controlled by the Output Register PWM_COUNT:
 $Ton = (PWM_COUNT - PWM_RELOAD) * TMRCLK$

If the Output Register PWM_COUNT value is 255 the TIMEROULT signal is always at high level.
 If the Output Register PWM_COUNT is 0, or less than the PWM_RELOAD value, TIMEROULT signal is always at low level.

NOTE. If the PWM_RELOAD value increases, the duty cycle resolution decreases.

By using a 20 MHz Master Clock a PWM frequency in the range between 1.2 Hz to 78.43 KHz may be obtained.

NOTE: The Timer, before using a new value of the counter or of the reload, has to complete the previous counting. If the counter/reload value is changed during counting, the new value of the timer counter is used only at the end of the previous counting phase. This happens both in Timer and in PWM mode.

WARNING: loading new values of the reload in the PWM_x_RELOAD registers, the PWM/Timer is immediately set on-fly. This can cause some side effects during the current counting cycle. The next cycles work normally. This occurs both in Timer and in PWM mode.

When the Timer is in Reset, or when the device is reset, the TOUT pin goes to threestate: it is recommended to use a pull-up or a pull-down resistor if this output is used to drive an external device.

9.3 Timer Interrupt

The TIMER can be programmed to generate an Interrupt request until the end of the count or when there is an Timer Stop signal (TSTRT). The Timer can generate programmable Interrupts into 4 different modes:

Interrupt mode 1: Interrupt on Timer Stop.

Interrupt mode 2: Interrupt on Rising Edge of TIMEROOUT.

Interrupt mode 3: Interrupt on Falling Edge of TIMEROOUT.

Interrupt mode 4: Interrupt on both edges of TIMEROOUT.

The Interrupt mode can be selected by means of INTSL and INTE bits of the REG_CONF5.

NOTE: *the interrupt on TIMEROOUT rising edge is also generated after the Start.*

WARNING: *If the PWM/Timer is configured with the Interrupt on Stop and the Start/Stop is configured as external, a low signal in the STRT pin determines a PWM/Timer interrupt even if the peripheral is off. If the interrupt is configured on falling edge, a reset signal generates an interrupt request.*

Table 9.1 Configuration Register 5 Description

Bit	Name	Value	Description
0	TIRST	0	Internal RESET
		1	Internal SET
1	TERST	0	External RESET on Level
		1	External RESET on Edge
2	TISTR	0	Internal STOP
		1	Internal START
3	TESTR	0	External START on Level
		1	External START on Edge
4	INTE	00	TIMER Interrupt on TIMEROOUT Falling Edge
		01	TIMER Interrupt on TIMEROOUT Rising Edge
		10	TIMER Interrupt on Both Edges of TIMEROOUT
		11	- not used
5			
6	INTSL	0	TIMER Interrupt on Counter Stop
		1	TIMER Interrupt on TIMEROOUT Edges
7	TMODE	0	TIMER MODE
		1	PWM MODE

Reset Configuration = "00000000"

Figure 9.5 Configuration Register 5

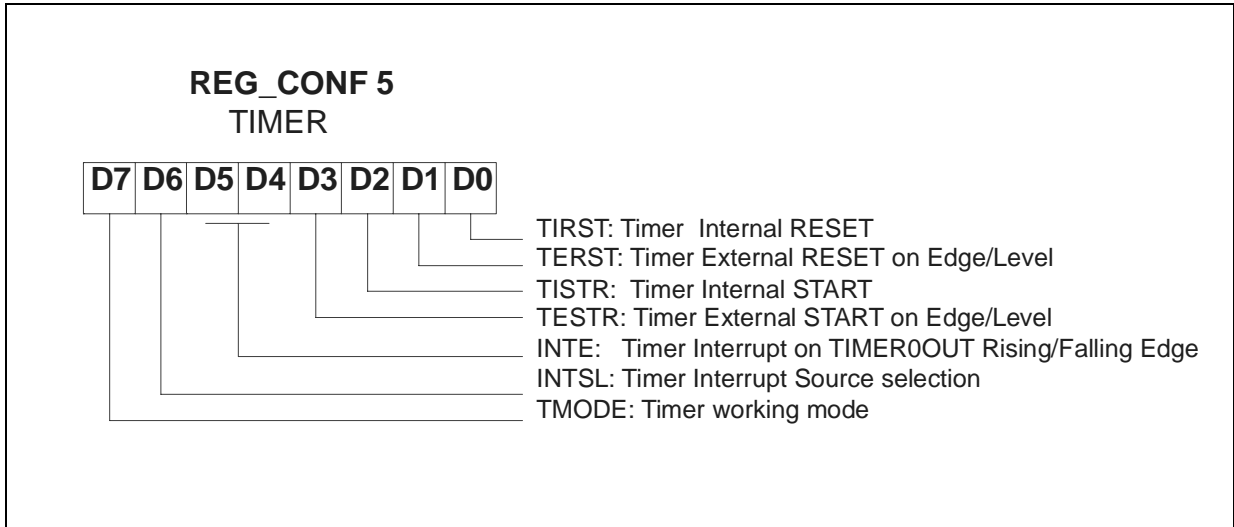

Reset Configuration = "00000000"

Table 9.2 Configuration Register 6 Description

Bit	Name	Value	Description
0	PRESC	00000	TIMER Clock = CLKM / 1
		00001	TIMER Clock = CLKM / 2
		00010	TIMER Clock = CLKM / 4
		00011	TIMER Clock = CLKM / 8
1		00100	TIMER Clock = CLKM / 16
		00101	TIMER Clock = CLKM / 32
		00110	TIMER Clock = CLKM / 64
2		00111	TIMER Clock = CLKM / 128
		01000	TIMER Clock = CLKM / 256
		01001	TIMER Clock = CLKM / 512
3		01010	TIMER Clock = CLKM/1024
		01011	TIMER Clock = CLKM/2048
		01100	TIMER Clock = CLKM/4096
4		01101	TIMER Clock = CLKM/8192
		01110	TIMER Clock=CLKM/16384
		01111	TIMER Clock=CLKM/32768
	10000	TIMER Clock=CLKM /65536	
5	TMRW	0	TIMEROUT Pulse type waveform
		1	TIMEROUT Square type waveform
6	-	-	Not used
7	-	-	Not used

Figure 9.6 Configuration Register 6

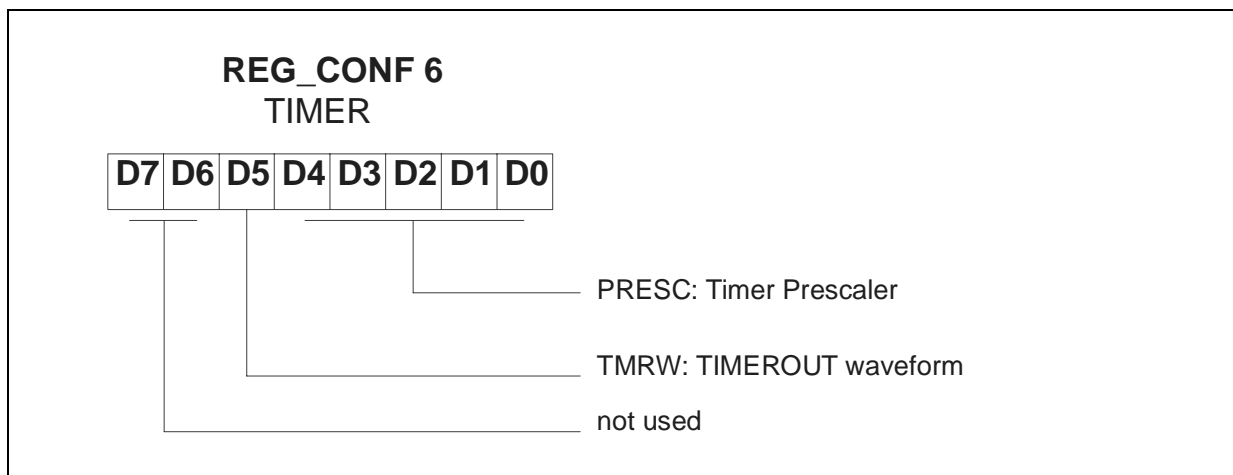
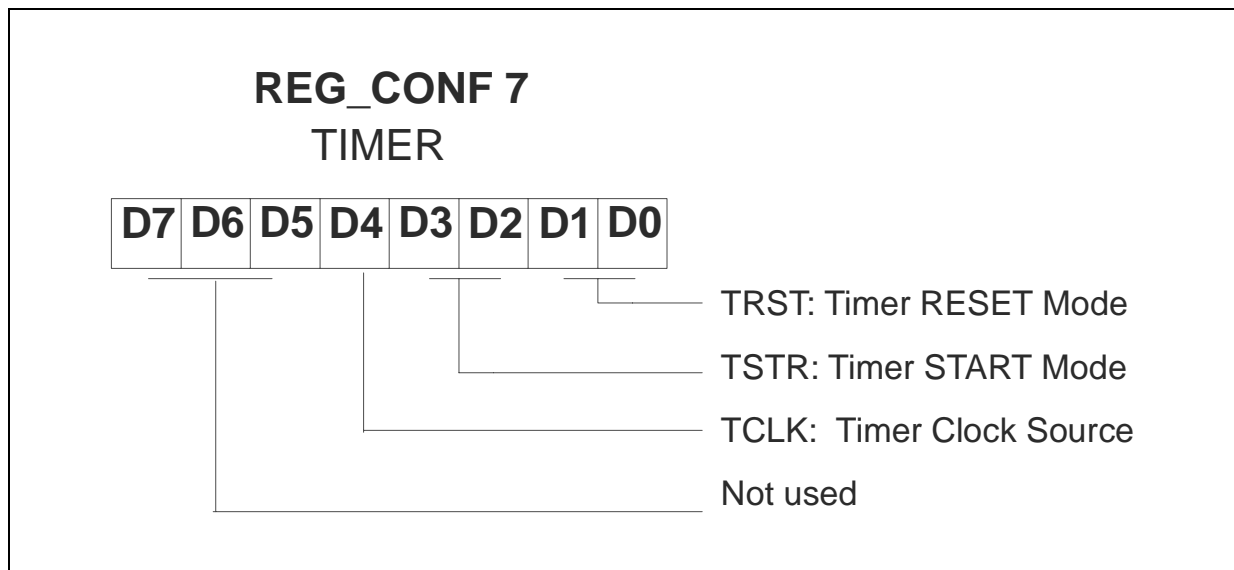

Table 9.3 Configuration Register 7 Description

Bit	Name	Value	Description
0	TRST	00	TIMER RESET Internal
		01	TIMER RESET External
1		10	TIMER RESET External or Internal
		11	Not used
2	TSTR	00	TIMER START Internal
		01	TIMER START External
3		10	TIMER START External or Internal
		11	Not used
4	TCLK	0	TIMER Clock Internal
		1	TIMER Clock External
5	NC	0	Must be kept to "0"
6	NC	-	Not used
7	NC	-	Not used

Reset Configuration = "00000000"

Figure 9.7 Configuration Register 7



10 TRIAC/PWM DRIVER

ST52x400/440/441 offers a peripheral able to generate a TROUT signal on PA0 pin (able to supply up to 25 mA), to drive an external device, like a TRIAC, an IGBT or a Power MOS. A Triac/PWM driver can perform 3 different working modes according to REG_CONF10(3:2) bits, MODE (see Table 10.3):

MODE = "00":	PWM
MODE = "01":	Burst Mode Triac Control (Thermal Regulations)
MODE = "1x":	Phase Angle Partialization Triac Control (Motor Control)

The Triac/PWM Driver can be initialized by using a value fixed by a control algorithm, and stored in the Register File. The value is loaded in the TRIAC_COUNT register (Output Register 9) by using the LDPR instruction and it can be read by using the LDRI instruction addressing the Input Register 17.

Figure 10.1 illustrates the internal structure of the Triac/PWM Driver.

PWM Mode

The PWM working mode selection can be obtained by setting REG_CONF10(3:2) bits, MODE, at "00" value.

In this working mode, the peripheral provides a signal with a fixed period and a variable duty cycle on the TROUT pin.

The PWM period can be generated starting from the internal master clock or an external clock signal applied in MAIN1 pin.

In both cases, the clock signal is divided by a 16-bit Prescaler, managed by REG_CONF8 and REG_CONF9 (Figure 10.2).

At each period, the duty cycle is fixed by an 8-bit value loaded in the TRIAC_COUNT register (Output Register 9). The duty cycle is proportional to the value: loading 50% duty cycle is obtained, loading 0 the output will be low (off) during all the period, loading 255 will be high (on).

By Using a 20 Mhz clock PWM frequencies in the range between 1.2 Hz to 78.4 Mhz may be obtained.

Figure 10.1 TRIAC/PWM Driver Block Diagram

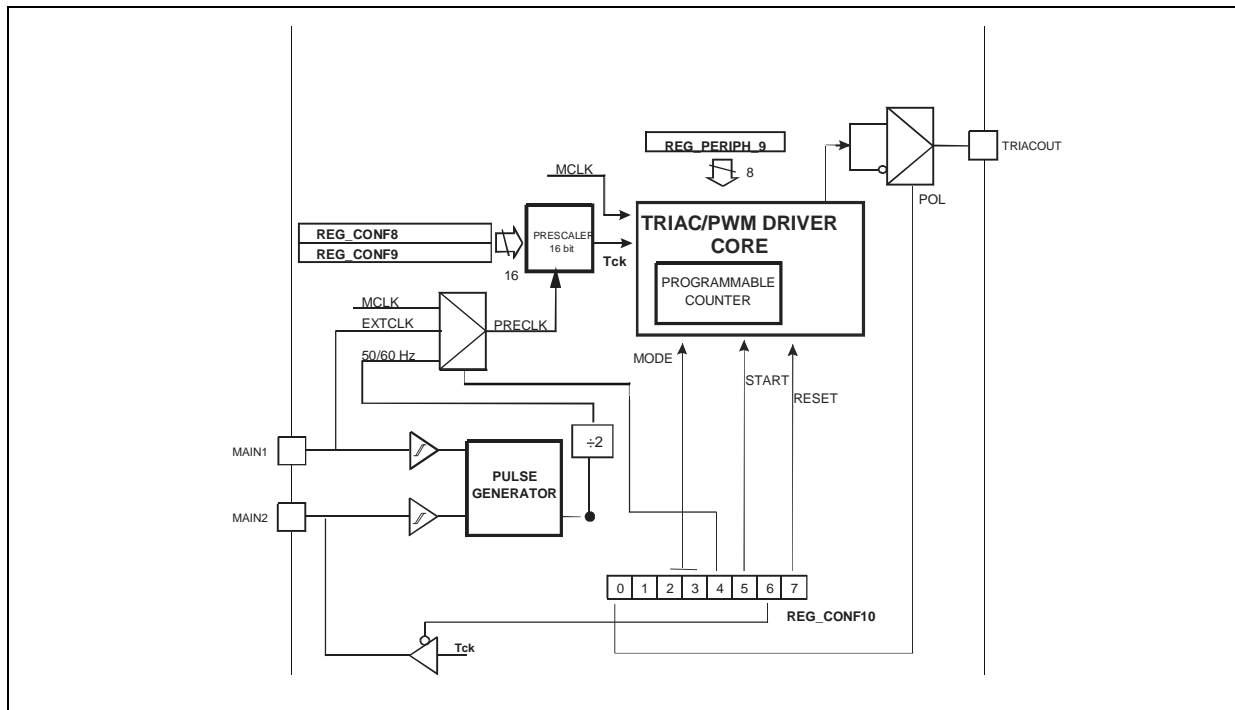

Burst Mode

The Burst principle is based on turning the TRIAC device on and off for a fixed integer number of mains voltage periods, in order to control the power transferred to the load.

In Burst Mode the peripheral provides a signal, with a fixed period T containing an integer number of pulses corresponding to the main voltage zero crossings, with a Duty Cycle that is proportional to the number of pulses that keep the TRIAC on (Figure 10.4).

The user can define the period T by means of the internal 16-bit prescaler, setting REG_CONF8 and REG_CONF9 (Figure 10.2). T is proportional to the main voltage period and is in the range [5.10, 334233.6]s if the main frequency is 50Hz.

The duty cycle is fixed at each period by an 8-bit value loaded in the TRIAC_COUNT register (Output Register 9). The duty cycle is proportional to the value: loading 50% duty cycle is obtained, loading 0 the output will be low (off) during all the period, loading 255 will be high (on).

The width and the polarity of the pulses can be programmed according to the TRIAC device and the circuit characteristics.

In order to work in Burst mode, the pre-post zero-crossing of main voltage must be detected by using an external inserting circuitry connected to the MAIN1 and MAIN2 pins (Figure 10.5).

This kind of TRIAC control is mainly used for thermal regulation.

Phase Angle Partialization Mode

Phase Angle Partialization method is based on turning on the TRIAC device only for a part (Phase Angle) of each main voltage period. When the phase angle is large, the energy (power) supplied to the load is low, viceversa when the phase angle is small, the energy supplied to the load is high.

In order to work in Phase Angle Partialization mode, the zero-crossing of main voltage must be detected by using an external inserting circuitry connected to the MAIN1 and MAIN2 pins or, optionally, only on MAIN1 pin (Figure 10.10).

In this working mode, the peripheral provides eight pulses after the time corresponding to the Phase Angle on the TROUT pin, obtained by setting the TRIAC_COUNT 8-bit register (Output Register 9) and the Prescaler (REG_CONF8 and REG_CONF9). By modifying the TRIAC_COUNT register the Phase Angle is controlled.

10.1 TRIAC/PWM Driver Setting

The TRIAC/PWM Peripheral can be SET or RESET through REG_CONF10(7) bit TCRST (Table 10.3) in all three working modes.

If the TRIAC/PWM Peripheral is SET and **only in PWM mode**, it is possible to START or STOP the internal counter of the peripheral without resetting it, through REG_CONF10(5) bit TCST (Table 10.3), in order to use the peripheral as an additional Timer. In the other modes **the TCST bit must be kept to “1”**.

NOTE: if TCRST is 0 (reset status) the TROUT pin output is in tristate.

Figure 10.2 TRIAC/PWM Configuration Registers 8 and 9

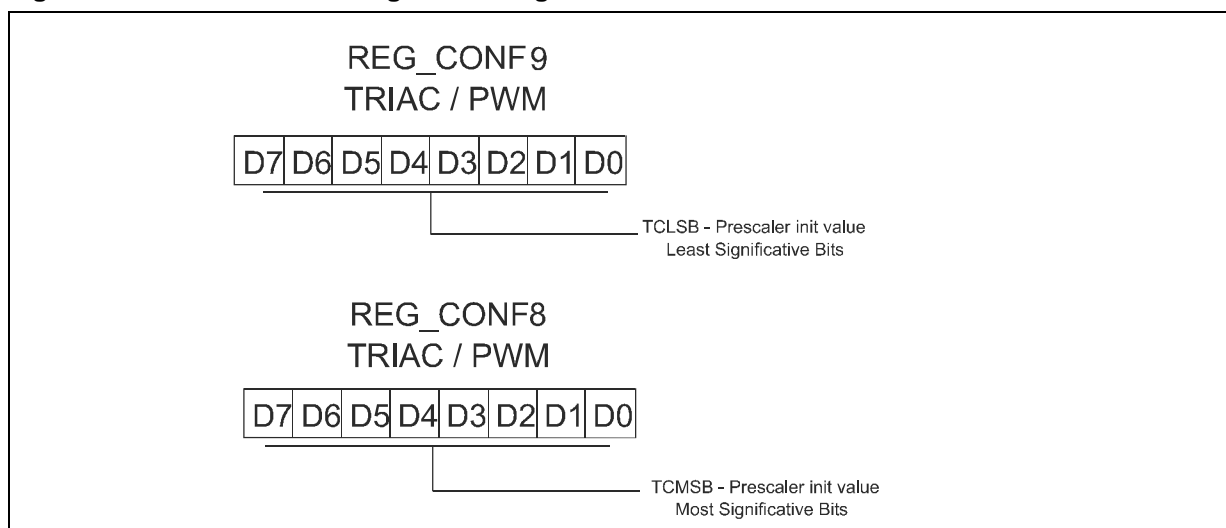

10.2 PWM Mode Settings

By using the 16-bit Prescaler (REG_CONF8 and REG_CONF9), the PWM period can be generated by dividing the internal master clock, an external clock signal applied to pin MAIN1, or the mains voltage frequency, using the circuit of Figure 10.10.

NOTE: *The external clock signal applied on MAIN1 pin must have a frequency that is at least two times smaller than the internal master clock.*

The clock source can be selected by using REG_CONF10(4) bit, CKSL (Table 10.3).

The period T of the PWM signal T_b (see Figure 10.4) can be calculated with the following formula:
 $T = 255 * T_{ck}$

where T_{ck} is the period of the signal in output of the 16-bit prescaler, according to the value stored in REG_CONF8 and REG_CONF9 pair (Figure 10.2).

By using a 20 MHz clock master a PWM frequency in the range 1.2 Hz to 78.4KHz may be obtained (Table 10.1).

Table 10.1 PWM Frequencies

MCLK Frequencies	1/T	
	min	max
5 MHz	1.2 Hz	19.6 KHz
10 MHz	0.6 Hz	39.2 KHz
20 MHz	0.3 Hz	78.4 KHz

The value T_{on} depends on the value set by the user in the TRIAC_COUNT Register (Output Register 9) by using the LDPR instruction. T_{on} and the corresponding duty cycle can be calculated from the following formulas:

$$T_{on} = TRIAC_COUNT * T_{ck}$$

$$Duty = TRIAC_COUNT / 255$$

The TRIAC_COUNT value can be changed on fly but it is updated only at the end of the signal period. If TRIAC_COUNT value is 255 then T_{off} is zero and TROUT signal is always equal to one during the period T.

According to REG_CONF10(0) configuration register bit, POL, the firing pulses polarity must be set.

IN PWM mode, it is possible to generate a programmable Interrupt in four different ways:

- 1) No Interrupt;
- 2) Interrupt on rising edge of the signal T_b (INT_R).
- 3) Interrupt on falling edge of the signal T_b (INT_F)
- 4) Interrupt on both edges of the signal T_b .

The Interrupt sources described above are always active; they can be masked through REG_CONF0(5:3) bits, INTSL (see Table 4.1).

NOTE: *If the Interrupt on the rising edge (INT_R) is not masked through REG_CONF0(4), the first Interrupt after the start occurs with a delay of a time period T. If TRIAC_COUNT is 255 or 0, the first interrupt after the start (either INT_R and INT_F) occurs at time T. In any case for TRIAC_COUNT equal to 255 or 0, INT_R and INT_F coincide and occur at each control period T.*

Figure 10.3 PWM Working Mode

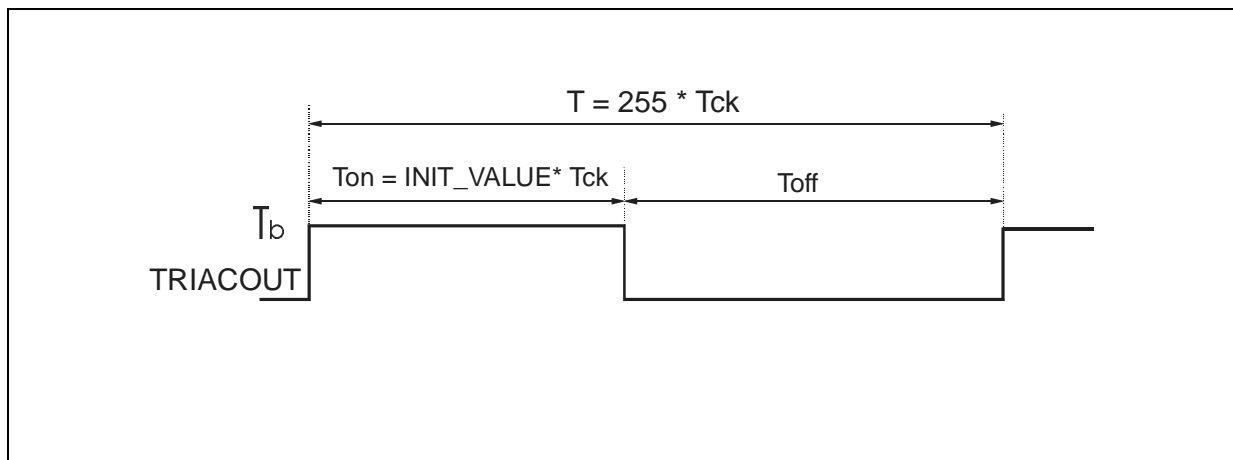

10.3 Burst Mode

When working in Burst mode, the synchronization with the mains is mandatory, therefore REG_CONF10(4) bit CKSL must be set to "1". (Table 10.3).

A square wave Tb is generated with a duty cycle proportional to the power the user needs to transfer to the load. A pulse is generated for each zero crossing of the mains voltage included in the Ton of the fixed period T. Figure 10.4 illustrates the typical Burst Control working mode. The period T of the signal Tb (Figure 10.4) is:

$$T = 255 * Tck$$

The signal Tck is generated by programming the 16-bit Prescaler by REG_CONF8 and REG_CONF9 (Figure 10.2). Tck is equal to the mains voltage frequency (50 or 60 Hz) divided by N+1, where N is an integer value in the range [0, 2¹⁶-1].

The value Ton is proportional to the value contained in TRIAC_COUNT Register (Output Register 9)

The number of generated pulses N_PULSES in TROUT pin is equal to:

$$N_PULSES = 2 * [(N+1) * TRIAC_COUNT]$$

where N is the value stored in the 16-bit prescaler. Therefore it is:

$$Ton = TRIAC_COUNT * Tck$$

The TRIAC_COUNT can be changed on fly and takes effect from the following period; the Prescaler value N instead is fixed since the beginning

and cannot be changed on fly.

The first pulse is obtained during the first zero crossing of the main voltage and the last one is generated after clock pulses included in the time period TRIAC_COUNT*Tck, where Tck is the Prescaler output, generated by using the main voltage frequency applied to MAIN1 and MAIN2 pins. This guarantees synchronization with the mains voltage frequency.

Ranges of the Tb signal period depend on the power line frequency and Prescaler (Table 10.2). In order to drive a Triac in Burst Mode a pulse sequence must be generated, which must be centered on the zero crossing of the power line as illustrated in Figure 10.7. Therefore, the pre zero crossing and the post zero crossing of the power line must be detected.

To detect the zero-crossing and also obtain the main voltage frequency, the user must generate MAIN1 and MAIN2 signals by using the circuit illustrated in Figure 10.5.

MAIN1 and MAIN2 signals are used in the block called PULSE GENERATOR of the peripheral (see Figure 10.1).

Table 10.2 TROUT Signal Period

Power Line Frequency	T	
	min	max
50 Hz	5.10 s	334233.60 s
60 Hz	4.25 s	278528.05 s

Figure 10.4 Burst Working Mode

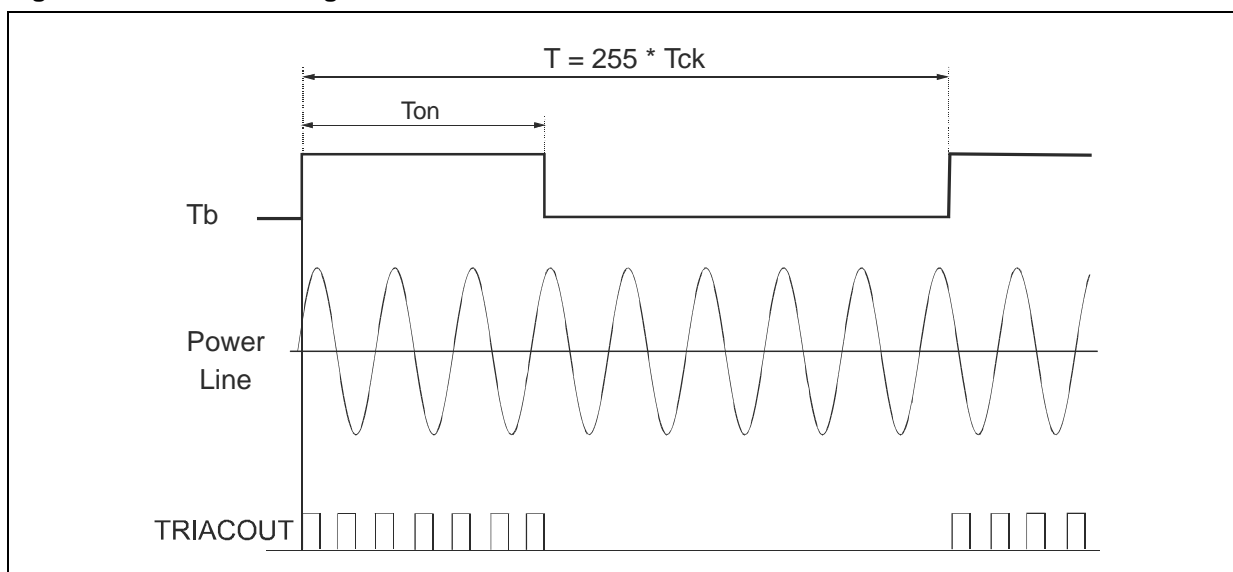

In particular, the pulses are generated by using the rising edge of the signal MAIN1 and the falling edge of the signal MAIN2. Figure 10.6 illustrates the generation of the Triac pulses T_p .

The first firing pulse for the Triac is generated on the zero crossing of the power line, while the next pulses are centered on the zero crossing. Generally, the Triac firing pulses start $1/2 T_p$ before the zero crossing and the length of the pulses is T_p , see Figure 10.6.

The length T_p of the pulses is programmable by using a 16 bit value UTP, obtained with REG_CONF19 bits, UTPMSB, and REG_CONF20, UTPLSB (see Figure 10.12 and Table 10.5):

$$T_p = T_{CLKM} * UTP$$

The value T_p is in the range $[0, 3.2] ms$ when the clock master is 20 MHz.

According to REG_CONF10(0) configuration register bit, POL, the firing pulses polarity may be set; in order to obtain positive or negative gate Triac currents, allowing to work respectively in I and IV quadrants, or in the II and III quadrants (see Figure 10.6).

The pulses polarity can be changed on fly with immediate effect.

Working in the II and III quadrant the peripheral implements the following procedure:

- 1) The firing pulse is set to "1" on the rising edge

Figure 10.5 Burst Mode Zero Crossing Circuit

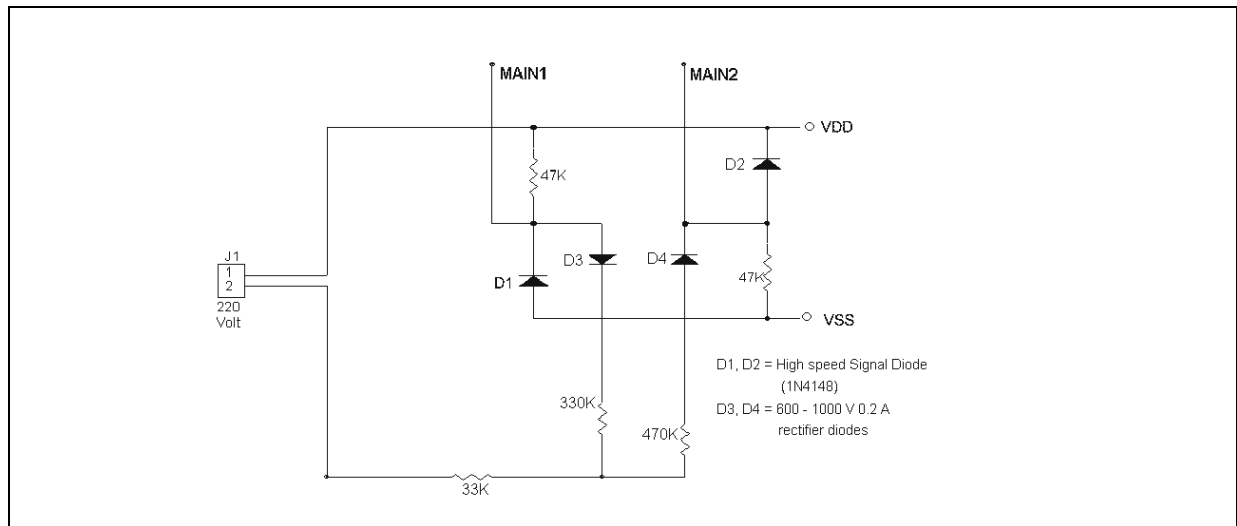

Figure 10.6 Burst Mode Zero Crossing Circuit

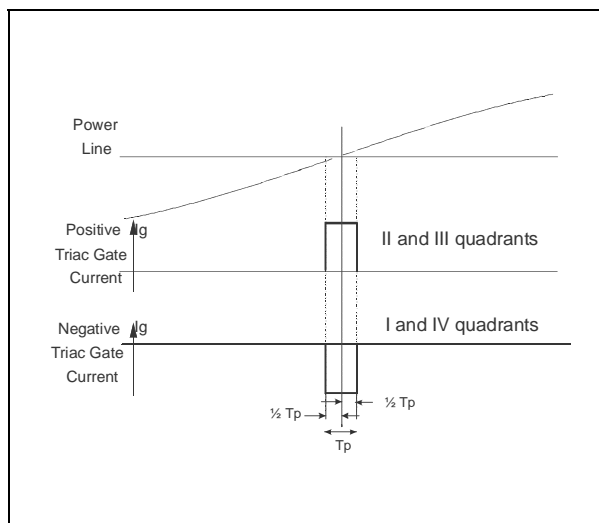
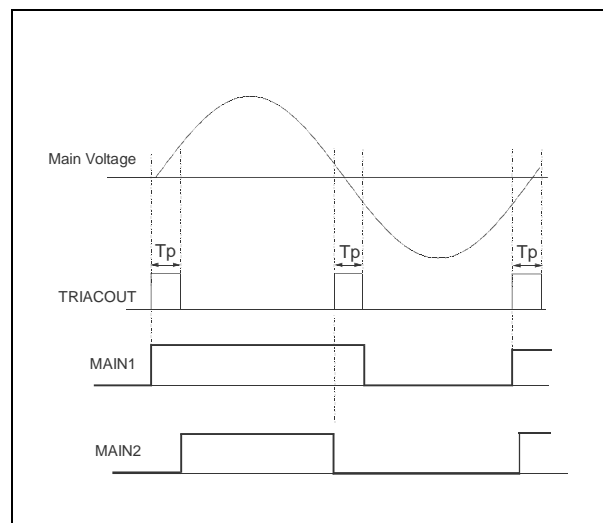

Figure 10.7 Burst Mode Zero Crossing



of MAIN1.

2) The firing pulse is reset to "0" after the time T_p fixed by program.

3) On the falling edge of MAIN2 the firing pulse is set to "1"

4) The firing pulse is reset to "0" after the time T_p fixed by program.

It is possible to generate a programmable Interrupt in the following ways:

1) No Interrupt;

2) Interrupt on the rising edge of the signal T_b (INT_R)

3) Interrupt on the falling edge of the signal T_b (INT_F)

4) Interrupt on both edges of the signal T_b .

5) Interrupt on each Triac pulse (INT_P)

If pulse width or TRIAC_COUNT are set to zero, no pulse on TROUT pin is generated and INT_P interrupt does not occur.

The Interrupt sources described above are always active; they can be masked through REG_CONF0(5:3) bits, INTSL (see Table 4.1).

10.4 Phase Angle Partialization Working Mode

In this mode Triac is controlled each semi-period of the mains voltage. The power transferred to the load is proportional to the CURRENT FLOW ANGLE γ . This kind of Triac control is suitable to drive the Triac with inductive load (i.e. universal or monophasic motors). Figure 10.8 illustrates the relation between the Phase Angle α and the Current Flow Angle γ .

The peripheral allows to control the Phase Angle or equivalently time T_1 (see Figure 10.9). It is possible to change Time T_1 setting the contents of the TRIAC_COUNT register (Output Register 9). T_1 is proportional to the value loaded in the TRIAC_COUNT register.

Different circuits for the zero crossing detection may be used, but MAIN1 signal rising edge must always be synchronized with the mains voltage zero crossing and MAIN2 signal falling edge must be synchronized with the following mains voltage zero crossing.

By using the external circuit illustrated in Figure 10.10, only one synchronization signal from the mains may be used, MAIN1. In this case, REG_CONF10(6) must be set to "1", MAIN2 signal coincides internally with MAIN1 and MAIN2 pin is left free for other functions. If main voltage frequency is equal to 50 Hz, then T_r is equal to 20 ms

(Figure 10.9) and T_1 is:

$$T_1 = \text{TRIAC_COUNT} * T_{\text{CKLM}} * (N+1)$$

being T_{CKLM} master clock period and N the Prescaler value (Configuration Registers 8 and 9).

NOTE: The user must verify that time T_1 is not larger than a fixed time T_{max} (8ms at 50 Hz) in order to avoid the firing of the Triac in the second half period of the mains voltage and to choose a suitable Prescaler value to avoid the shifting of the pulse sequence in the following semi-period.

In order to avoid problems for the Triac firing when the load is inductive 8 different pulses are generated by the peripheral (Figure 10.10). Their width, equal the semiperiod $T_i/2$, is programmable by using registers REG_CONF19 (UTPMSB) and REG_CONF20 (UTPLSB) and is provided by the formula:

$$T_i/2 = T_{\text{CKLM}} * \text{UTP}$$

NOTE: the choice of UTP value must be done by the user paying attention to the fact that the duration of the 8 pulses train must be such that added to T_1 , it does not fall into the second half period of the mains voltage. In fact by using a clock master equal to 20 MHz and the full 16 bit value by ConfReg19 and 20, the pulse width would be in the range [0.2, 3.28] ms.

The duty cycle of T_i pulse is always 50%. The choice of the pulse width must be done according to TRIAC device specifics and must be set from the beginning of the program. To change width during program execution it is necessary to RESET the peripheral.

According to REG_CONF10(0) configuration register bit, POL, the firing pulses polarity must be set.

A programmable interrupt may be generated in four different ways:

1) no Interrupt;

2) Interrupt on the rising edge of the signal MAIN1 (INT_R)

3) Interrupt on the falling edge of the signal MAIN2 (INT_F)

4) Interrupt on both the edges of the signal MAIN1

5) Interrupt on rising edge of first pulse after T_1 (INT_P)

If UTP is 0, TROUT signal remains at 0 (or 1, if POL=1), however after the time T_1 , the interrupt INT_P is generated.

The Interrupt sources described above are always active; they can be masked through REG_CONF0(5:3) bits, INTSL (see Table 4.1).

Figure 10.8 Phase angle Partialization Mode

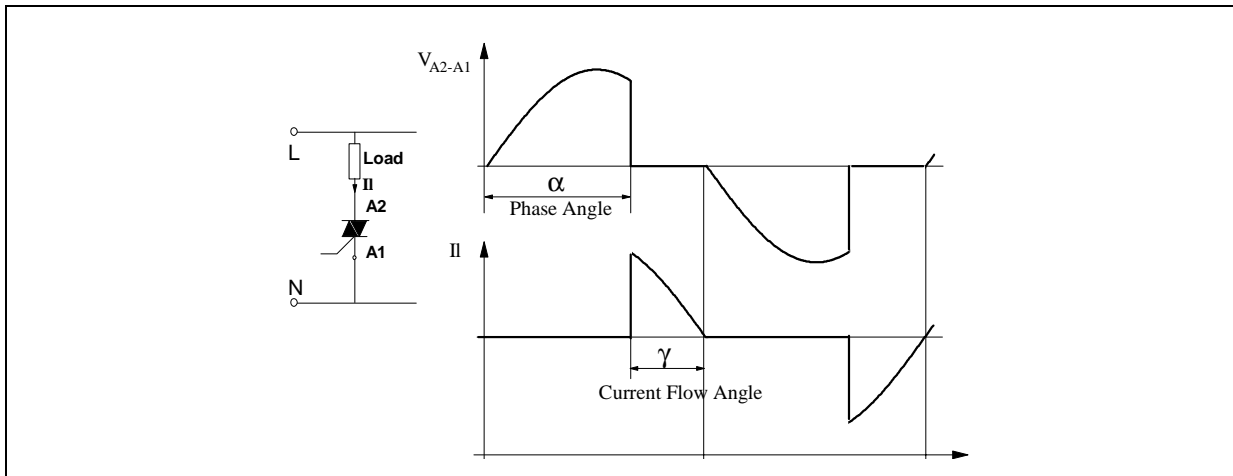

Table 10.3 Configuration Register 10

Bit	Name	Value	Description
0	POL	0	Set Positive Output Pulse Polarity
		1	Set Negative Output Pulse Polarity
1	-	-	Not used
2	MODE	00	PWM Mode
		01	Burst Mode
3		1X	Phase Partialization
4	CKSL	0	Internal Clock Master
		1	External Clock on Main1
5	TCST	0	Triac Stop
		1	Triac Start
6	IOSL	0	Set MAIN2 as Alternate Function
		1	MAIN2 coinciding with MAIN1
7	TCRST	0	Triac Reset
		1	Triac Set

Reset Configuration = "00000000"

Table 10.4 Configuration Register 19

Bit	Name	Value	Description
0 - 7	UTPMSB		Output Impulse Width most significant bit

Table 10.5 Configuration Register 20

Bit	Name	Value	Description
0 - 7	UTPLSB		Output Impulse Width least significant bit

Reset Configuration = "00000000"

Figure 10.9 Phase Angle Partialization Mode

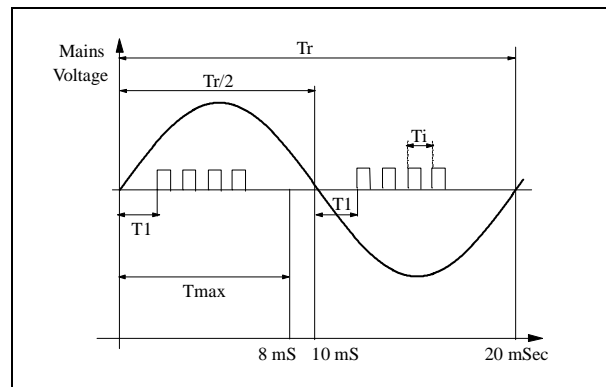

Figure 10.10 Phase Angle Partialization Zero Crossing Circuit

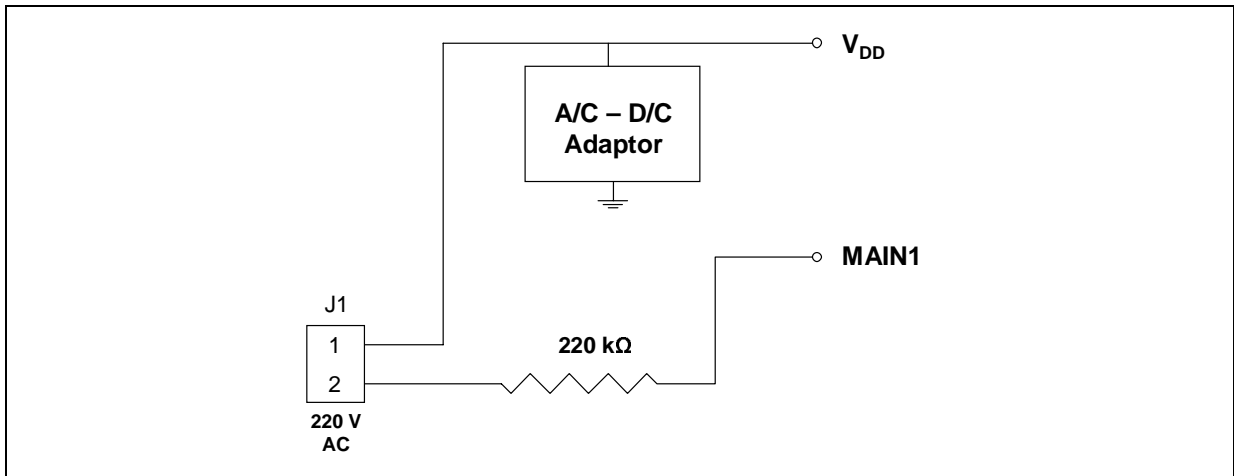

Figure 10.11 TRIAC/PWM Configuration Registers 10

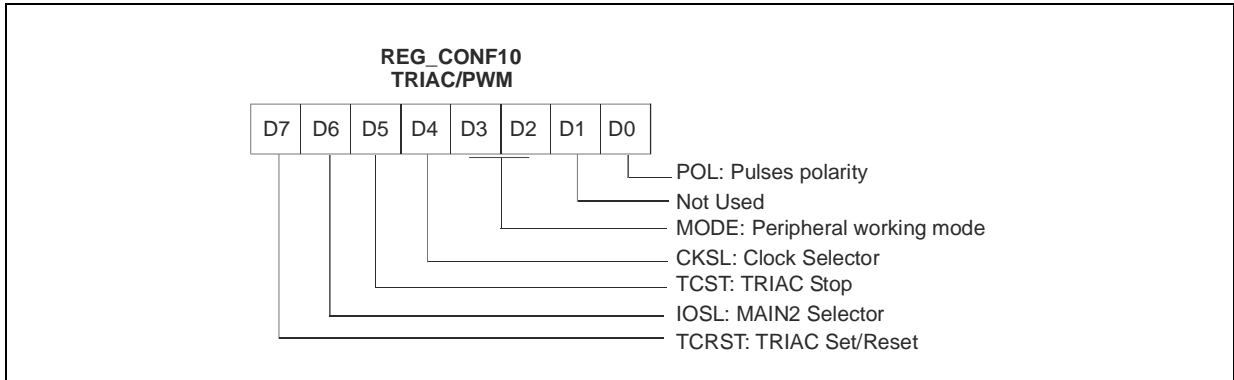
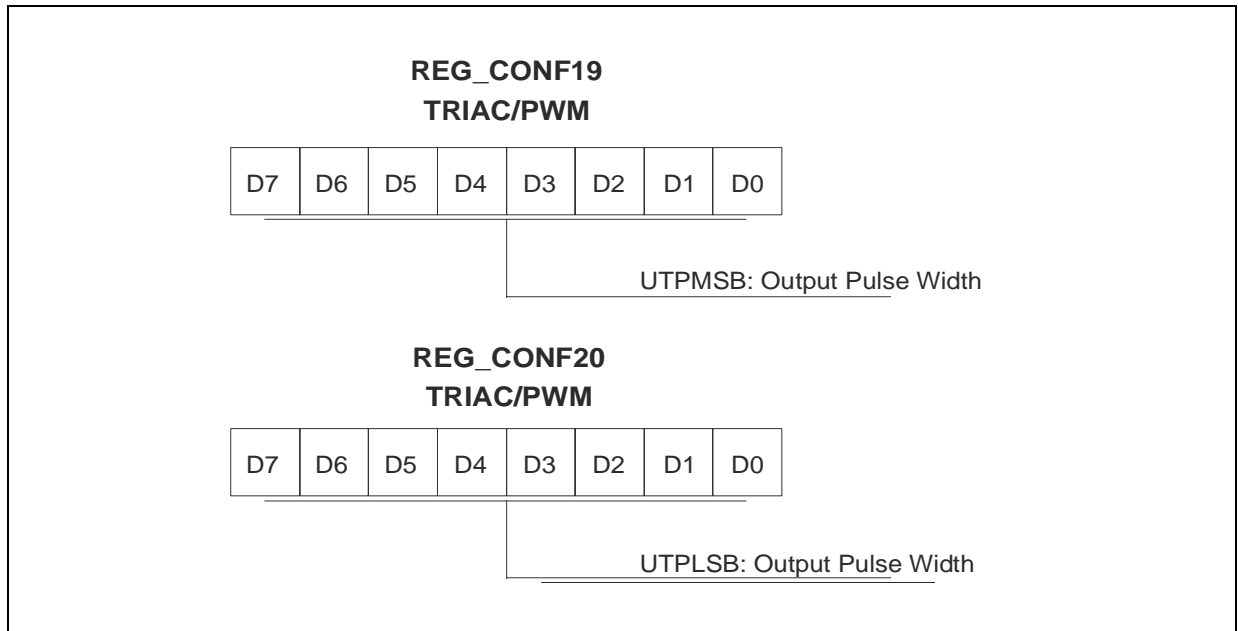

Figure 10.12 TRIAC/PWM Configuration Registers 19 and 20



11 ELECTRICAL CHARACTERISTICS

11.1 Parameter Conditions

Unless otherwise specified, all voltages are referred to V_{SS} .

11.1.1 Minimum and Maximum values.

Unless otherwise specified, the minimum and maximum values are guaranteed in the worst conditions of environment temperature, supply voltage and frequencies production testing on 100% of the devices with an environmental temperature at $T_A=25^{\circ}C$ and $T_A=T_{Amax}$ (given by the selected temperature range).

Data is based on characterization results, design simulation and/or technology characteristics are indicated in the table footnotes and are not tested in production. The minimum and maximum values are based on characterization and refer to sample tests, representing the mean value plus or minus three times the standard deviation (mean $\pm 3\Sigma$).

11.1.2 Typical values.

Unless otherwise specified, typical data is based on $T_A=25^{\circ}C$, $V_{DD}=5V$ (for the $4.5 \leq V_{DD} \leq 5.5V$ voltage range). They are provided only as design guidelines and are not tested.

11.1.3 Typical curves.

Unless otherwise specified, all typical curves are provided only as design guidelines and are not tested.

Figure 11.1 Pin loading conditions

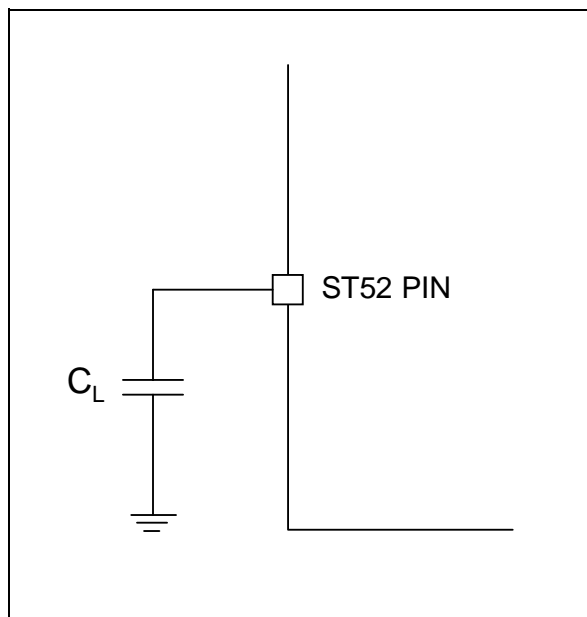

11.1.4 Loading capacitor. The loading condition used for pin parameter measurement is illustrated in Figure 11.1.

11.1.5 Pin input voltage.

Input voltage measurement on a pin of the device is described in Figure 11.2

Figure 11.2 Pin input Voltage

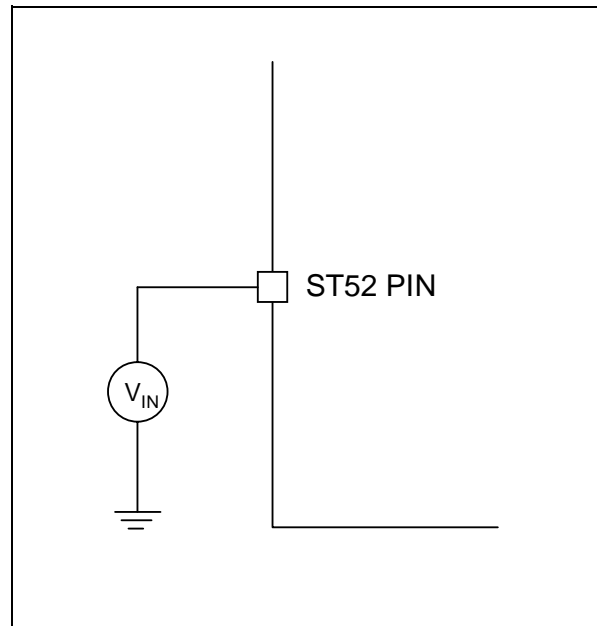

11.2 Absolute Maximum Ratings

Stresses above those listed as “absolute maximum ratings” may cause permanent damage to the device. This is a stress rating only.

Functional operation of the device under these conditions is not implied. Exposure to maximum rating conditions for extended periods may affect device reliability.

Table 11.1 Voltage Characteristics

Symbol	Ratings	Maximum Value	Unit
$V_{DD}-V_{SS}$	Supply voltage	6.5	V
$ V_{SSA}-V_{SS} $	Variation between digital and analog ground pins	50	mV
V_{IN}	Input voltage on Vpp	$V_{SS}-0.3$ to 13	V
	Input voltage on any other pin ^{1) & 2)}	$V_{SS}-0.3$ to $V_{DD}+0.3$	
V_{DESD}	Electro-static discharge voltage	4000	

Table 11.2 Current Characteristics

Symbol	Ratings	Maximum Value	Unit
I_{VDD}	Total current in V_{DD} power lines (source) ³⁾	100	mA
I_{VSS}	Total current in V_{SS} ground lines (sink) ³⁾	100	
I_{IO}	Output current sunk by any standard I/O and control pin	25	
	Output current source by any I/Os and control pin	-25	
$I_{INJ(PIN)}$	Injected current on V_{PP} pin	± 5	
	Injected current on RESET pin	± 5	
	Injected current on OSCin and OSCout pins	± 5	
	Injected current on any other pin ⁴⁾	± 5	
$\Sigma I_{INJ(PIN)}$	Total Injected current (sum of all I/O and control pins) ⁴⁾	± 20	

Table 11.3 Thermal Characteristics

Symbol	Ratings	Maximum Value	Unit
T_{STG}	Storage temperature range	-65 to +150	°C
T_J	Maximum junction temperature	150	°C

Notes:

1. Connecting RESET and I/O Pins directly to VDD or VSS could damage the device if the unintentional internal reset is generated or an unexpected change of I/O configuration occurs (for example, due to the corrupted program counter). In order to guarantee safe operation, this connection has to be performed via a pull-up or pull-down resistor (typical: 4.7k Ω for RESET, 10K Ω for I/Os). Unused I/O pins must be tied in the same manner to VDD or VSS according to their reset configuration.

2. When the current limitation is not possible, the V_{IN} absolute maximum rating must be respected, otherwise refer to $I_{INJ(PIN)}$ specification. A positive injection is induced by $V_{IN}>V_{DD}$ while a negative injection is induced by $V_{IN}<V_{SS}$ to $I_{INJ(PIN)}$ specification. A positive injection is $V_{IN}>V_{DD}$ while a negative injection is induced by $V_{IN}<V_{SS}$.

3. All power (VDD) and ground (VSS) lines must always be connected to the external supply.

4. When several inputs are submitted to a current injection, the maximum $\Sigma I_{INJ(PIN)}$ is the absolute sum of the positive and negative injected currents (instantaneous values).

11.3 Recommended Operating Condition

Operating condition: $V_{DD}=5V\pm 10\%$; $T_A=0/125^{\circ}C$ (unless otherwise specified).

Table 11.4 Recommended Operating Conditions

Symbol	Parameter	Test Condition	Min.	Typ.	Max	Unit
$V_{DD}^{2)}$	Operating Supply	Refer to Figure 11.3	2.7		5.5	V
V_{PP}	Programming Voltage		11.4	12	12.6	
V_O	Output Voltage		V_{SS}		V_{DD}	
V_{SSA}	Analog Ground		$V_{SS}-0.3$	V_{SS}	$V_{SS}+0.3$	
$f_{OSC}^{1)2)}$	Oscillator Frequency		1		20	MHz

Notes:

1. It is recommended to insert a capacitor between V_{DD} and V_{SS} for improving noise rejection. Recommended values are 10 μF (electrolytic or tantalum) and/or 100 nF (ceramic).
2. A lower V_{DD} decreasing f_{osc} (see Figure 11.3). Data illustrated in the figure are characterized but not tested.

Figure 11.3 f_{osc} Maximum Operating Frequency versus VDD supply (*)

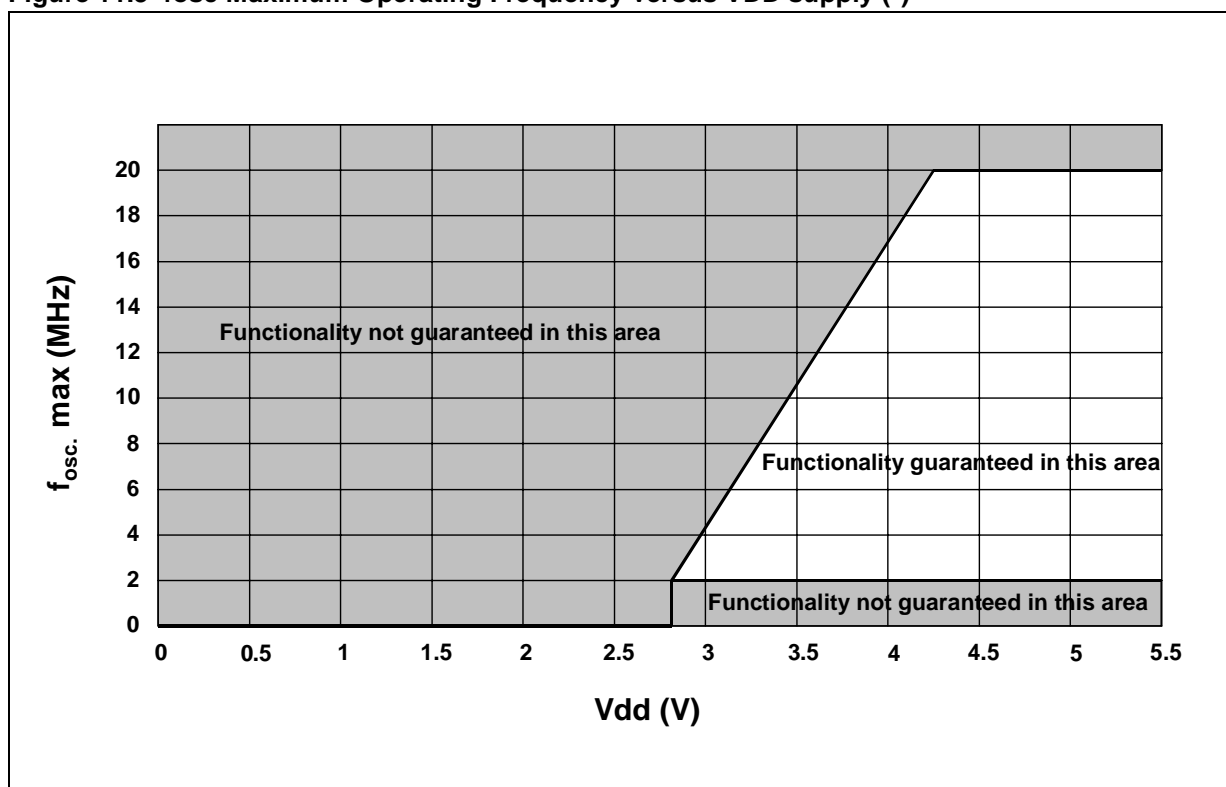

(*) Only digital parts of the device: the Analog Comparator cannot work with supply voltage lower than 4.5 V.

11.4 Supply Current Characteristics

Supply current is mainly a function of the operating voltage and frequency. Other factors such as I/O pin loading and switching rate, oscillator type, internal code execution pattern and temperature, also have an impact on the current consumption.

The test condition in RUN mode for all the IDD measurements are:

OSCin = external square wave, from rail to rail;

OSCOut = floating;

All I/O pins tristated pulled to VDD

TA=25°C

Table 11.5 Supply Current in RUN and WAIT Mode

Symbol	Parameter	Conditions	Typ	Max ³⁾	Unit	
IDD	Supply current in RUN mode ¹⁾	VDD=5V±5% TA=25°C	fosc=2 Mhz	6.48	6.48	mA
			fosc=4 Mhz	7.95	8.16	
			fosc=5 Mhz,	9.08	9.27	
			fosc=10	15.5	15.6	
			fosc=20	28.3	28.92	
	Supply current in WAIT mode ²⁾		fosc=2 MHz	4.4	4.41	
			fosc=4 MHz	6.0	6.09	
			fosc=5 MHz	6.6	6.89	
			fosc=10	12.2	12.31	
			fosc=20	23.0	23.07	

Notes:

1. CPU running with memory access, all I/O pins in input mode with a static value at VDD (no load), all peripherals switched off; clock input (OSCin driven by external square wave).
2. CPU in WAIT mode with all I/O pins in input mode with a static value at VDD (no load), all peripherals switched off; clock input (OSCin driven by external square wave).
3. Data based on characterization results, tested in production at VDDmax and foscmax.

Figure 11.4 Typical IDD in RUN vs fosc

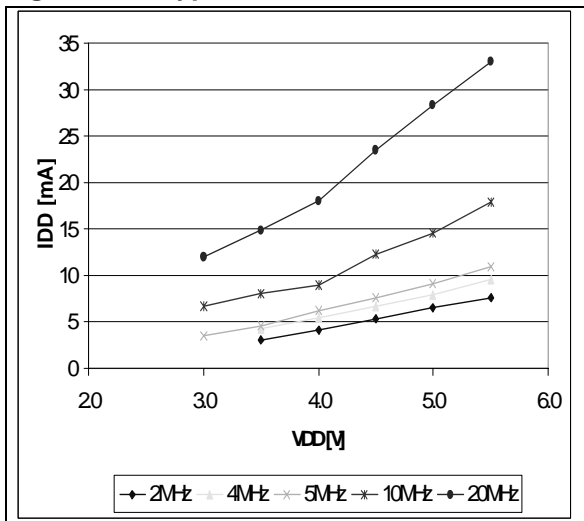

Figure 11.5 Typical IDD in WAIT vs fosc

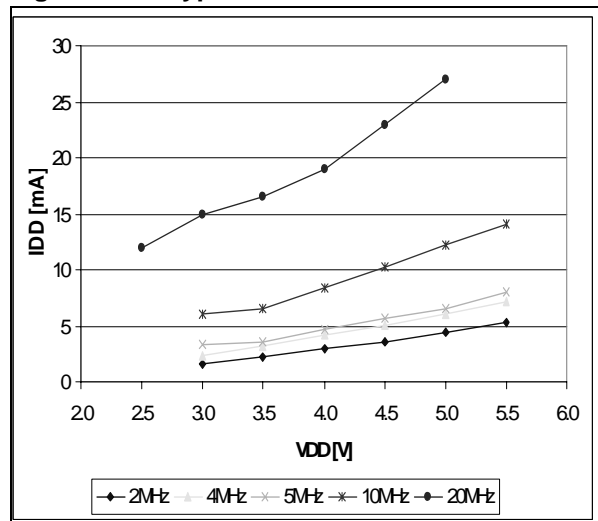

Table 11.6 Supply Current in HALT Mode

Symbol	Parameter	Conditions	Typ ¹⁾	Max	Unit
I _{DD}	Supply current in HALT mode ²⁾	3.0 V ≤ V _{DD} ≤ 5.5 V	0.6	0.68	μA

Notes:

1. Typical data is based on TA = 25 °C
2. All I/O pins in input mode with a static value at V_{DD} (no load)

11.5 Brown-Out Detector characteristics**Table 11.7 Brown-out detector**

Symbol	Parameter	Conditions	Min	Typ	Max	Unit
BOD _L	BOD Threshold low			3.8		V
BOD _H	BOD Threshold high			4.1		V
t _{BODL}	Duration of filtered noise			100		clock cycles

Notes:

1. Data based on characterization results
2. Measurement done with dV/dt fixed

11.6 Clock and Timing Characteristics

Operating Conditions: $V_{DD}=5V \pm 5\%$, $T_A=0/125^{\circ}C$, unless otherwise specified

Table 11.8 General Timing Parameters

Symbol	Parameters	Test Condition	Min	Typ.	Max	Unit
f_{osc}	Oscillator Frequency		1		20	MHz
t_{CLH}	Clock High		25		250	nS
t_{CLL}	Clock Low		25		250	
t_{SET}	Setup	See Fig. 11.6		5		
t_{HLD}	Hold	See Fig. 11.6		5		
t_{WRESET}	Minimum Reset Pulse	$f_{osc}=20MHz$	100			
t_{WINT}	Minimum External	$f_{osc}=20MHz$	100			
t_{IR}	Input Rise Time	See Fig. 11.7			15	
t_{IF}	Input Fall Time	See Fig. 11.7			15	
t_{OR}	Output Rise Time	$C_{LOAD}=10pF$		10		
t_{OF}	Output Fall	$C_{LOAD}=10pF$		10		

Figure 11.6 Data Input Timing

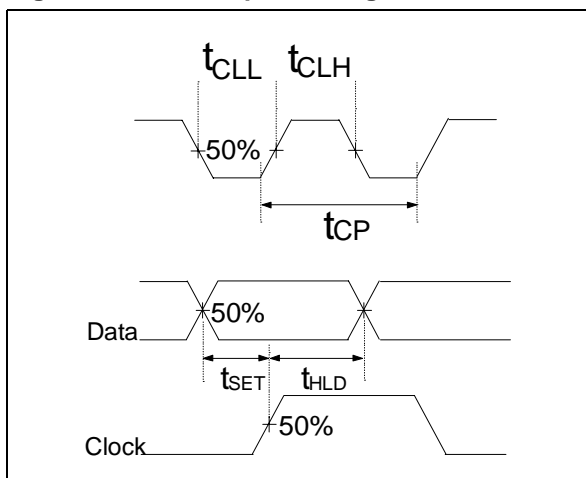
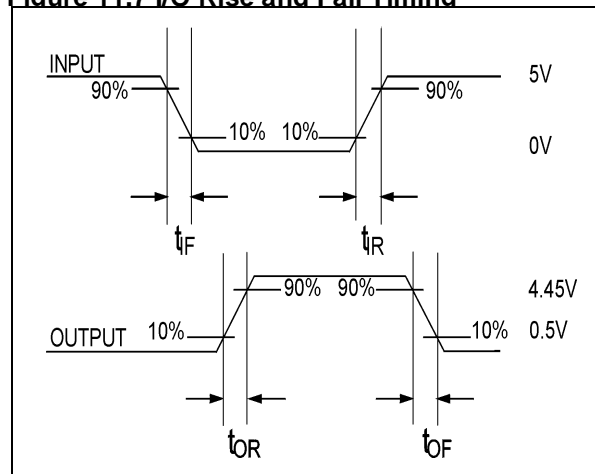

Figure 11.7 I/O Rise and Fall Timing



11.7 Memory Characteristics

Subject to general operating conditions for V_{DD} , f_{osc} and T_A , unless otherwise specified.

Table 11.9 RAM and Registers

Symbol	Parameter	Conditions	Min.	Typ.	Max	Unit
V_{RM}	Data retention mode ¹⁾	HALT mode (or RESET)	1.6			V

Table 11.10 EPROM Program Memory

Symbol	Parameter	Conditions	Min.	Typ.	Max	Unit
WERASE	UV lamp	Lamp wavelength 2537 Å		15		Watt, sec/cm ²)
tERASE	Erase time ²⁾	UV lamp is placed 1 inch from the device window without any interposed filters	10		20	min.
tRET	Data Retention	$T_A = +55^{\circ}\text{C}$	20			years

Notes:

1. Minimum V_{DD} supply voltage without losing data stored into RAM (in HALT mode or under RESET) or into hardware registers (only in HALT mode). Guaranteed by construction, not tested in production.
2. Data is provided only as a guideline.

11.8 ESD Pin Protection Strategy

In order to protect an integrated circuit against Electro-Static Discharge the stress must be controlled to prevent degradation or destruction of the circuit elements. Stress generally affects the circuit elements, which are connected to the pads but can also affect the internal devices when the supply pads receive the stress. The elements that are to be protected must not receive excessive current, voltage, or heating within their structure.

An ESD network combines the different input and output protections. This network works by allowing safe discharge paths for the pins subject to ESD stress. Two critical ESD stress cases are

presented in Figure 11.8 and Figure 11.9 for standard pins.

11.8.1 Standard Pin Protection

In order to protect the output structure the following elements are added:

- A diode to V_{DD} (3a) and a diode from V_{SS} (3b)
- A protection device between V_{DD} and V_{SS} (4)

In order protect the input structure the following elements are added:

- A resistor in series with pad (1)
- A diode to V_{DD} (2a) and a diode from V_{SS} (2b)
- A protection device between V_{DD} and V_{SS} (4)

Figure 11.8 Safe discharge path subjected to ESD stress

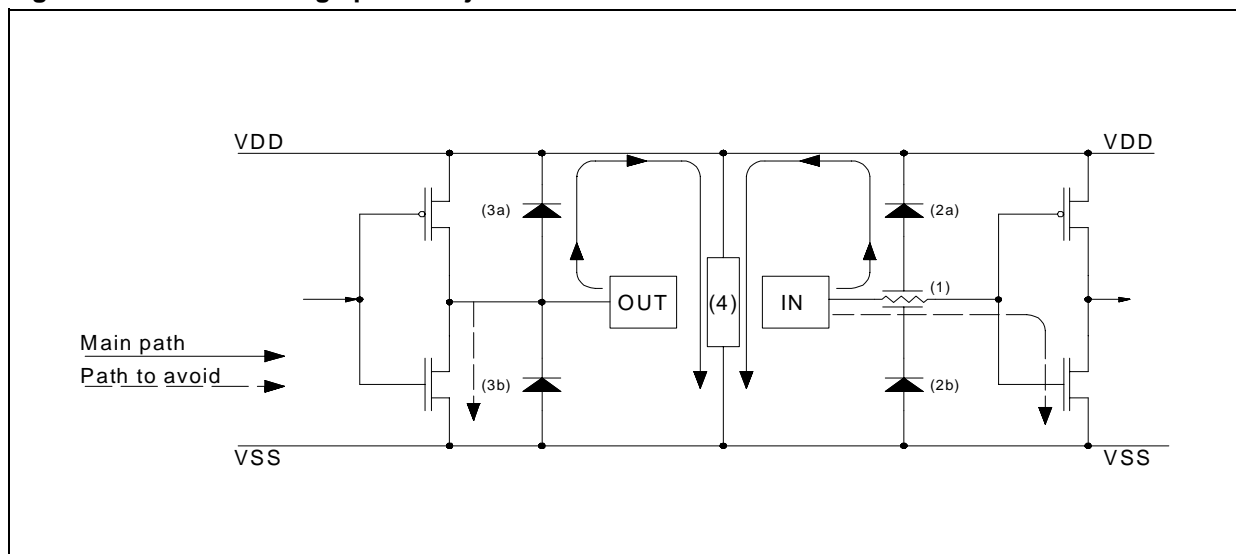
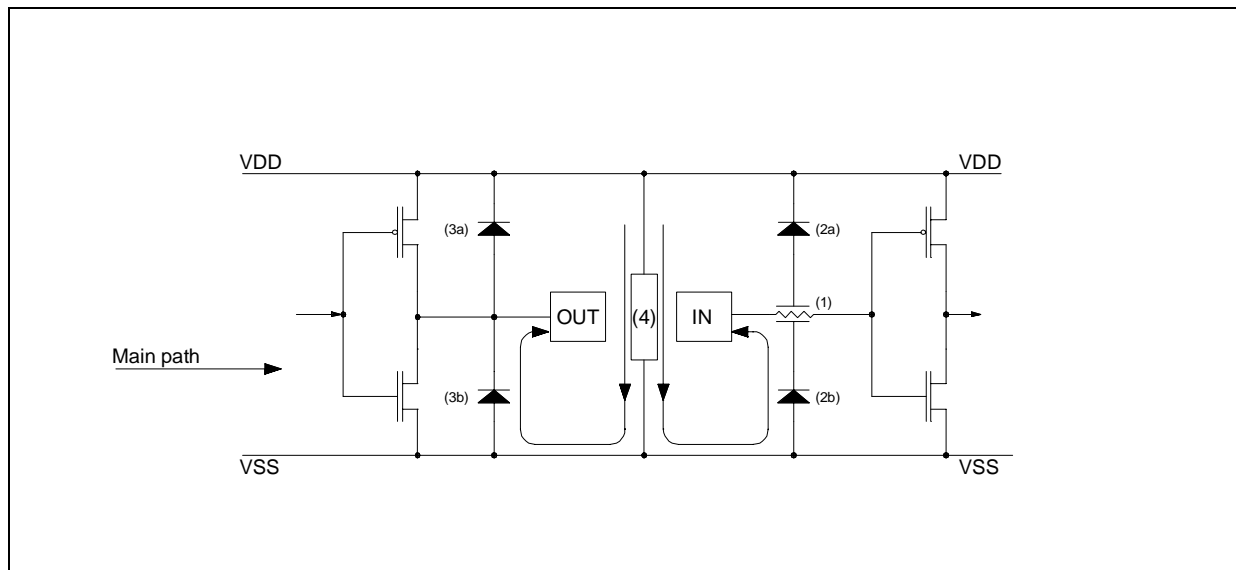

Figure 11.9 Negative Stress on a Standard Pad vs. VDD



11.9 Port Pin Characteristics

11.9.1 General Characteristics.

Subject to general operating condition for V_{DD} , f_{osc} , and T_A , unless otherwise specified.

Symbol	Parameter	Condition	Min	Typ ¹⁾	Max	Unit
V_{IL}	CMOS type low level input voltage. Port B pins. (See Fig 11.13)				1.5	V
	TTL type Schmitt trigger low level input voltage. Port A and Port C pins. (See Fig. 11.12)				0.8	
V_{IH}	CMOS type high level input voltage. Port B pins. (See Fig 11.13)		3.3			
	TTL type Schmitt trigger high level input voltage. Port A and Port C pins. (See Fig. 11.12)		2.2			
V_{hys}	Schmitt trigger voltage hysteresis ²⁾			1		
I_L	Input leakage current	$V_{SS} \leq V_{IN} \leq V_{DD}$			± 1	
I_S	Static current consumption ³⁾	Floating input mode			200	

Notes:

1. Unless otherwise specified, typical data is based on $T_A=25\text{ }^\circ\text{C}$ and $V_{DD}=5\text{ V}$
2. Hysteresis voltage between Schmitt trigger switching level. Based on characterization results, not tested in production.

Subject to general operating conditions for V_{DD} , f_{osc} , and T_A , unless otherwise specified.

Table 11.11 Output Voltage Levels

Symbol	Parameter	Conditions	Min	Typ	Max	Unit
$V_{OL}^{1)}$	Output low level voltage for standard I/O pin when 8 pins are sunk at same time.	$V_{DD}=5V, I_{IO}=+8mA$			$V_{SS}+0.4$	V
$V_{OH}^{2)}$	Output high level voltage for standard I/O pin when 8 pins are sourced at same time.	$V_{DD}=5V, I_{IO}=-8mA$	$V_{DD}-0.5$			

Notes:

1. The I_{IO} current sunk must always respects the absolute maximum rating specified in Section 11.2 and the sum of I_{IO} (I/O ports and control pins) must not exceed I_{VSS}
2. The I_{IO} sourced current must always respect the absolute maximum rating specified in Section 11.2 and the sum of I_{IO} (I/O ports and control pins) must not exceed I_{VDD} .

Figure 11.10 TTL-Level input Schmitt Trigger

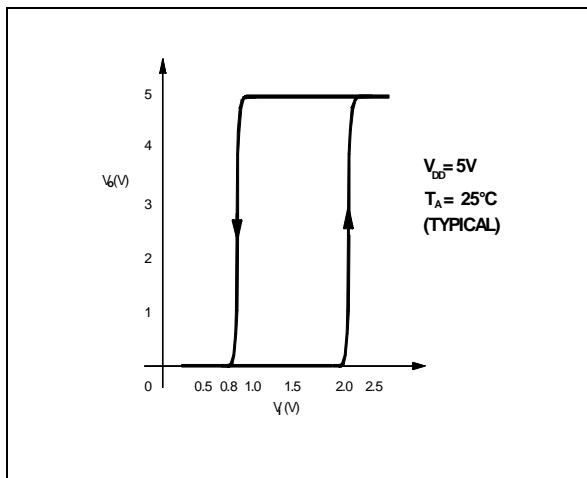
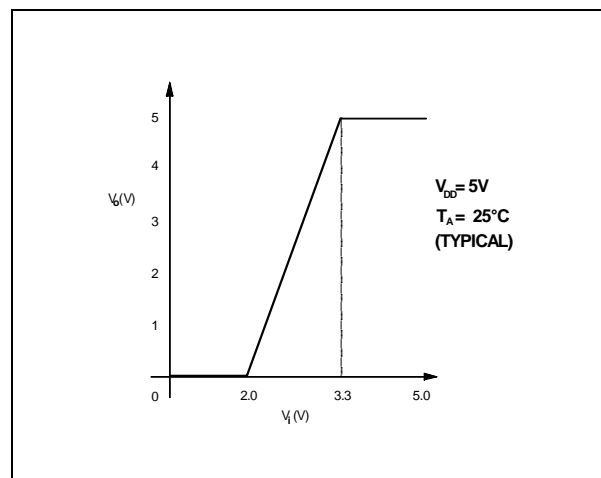

Figure 11.11 Port B pins CMOS-level input



Subject to general operating condition for V_{DD} , f_{osc} , and T_A , unless otherwise specified.

Table 11.12 Output Driving Current

Symbol	Parameter	Test Conditions	Min	Typ	Max	Unit
RS	Input protection resistor	All input Pins		1		kΩ
CS	Pin Capacitance	All input Pins		5		pF
Rpu	Pull-up resistor (*)	All input Pins		22		kΩ

(*) ST52T400 and ST52X440 only

Figure 11.12 Port A and Port C pin Equivalent Circuit (ST52T400 and ST52X440)

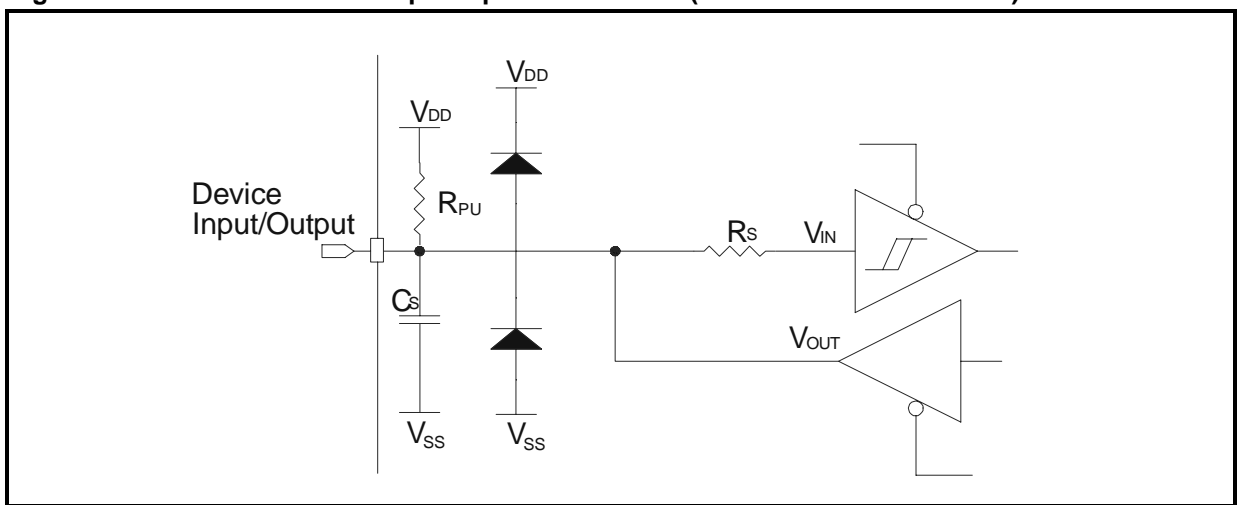
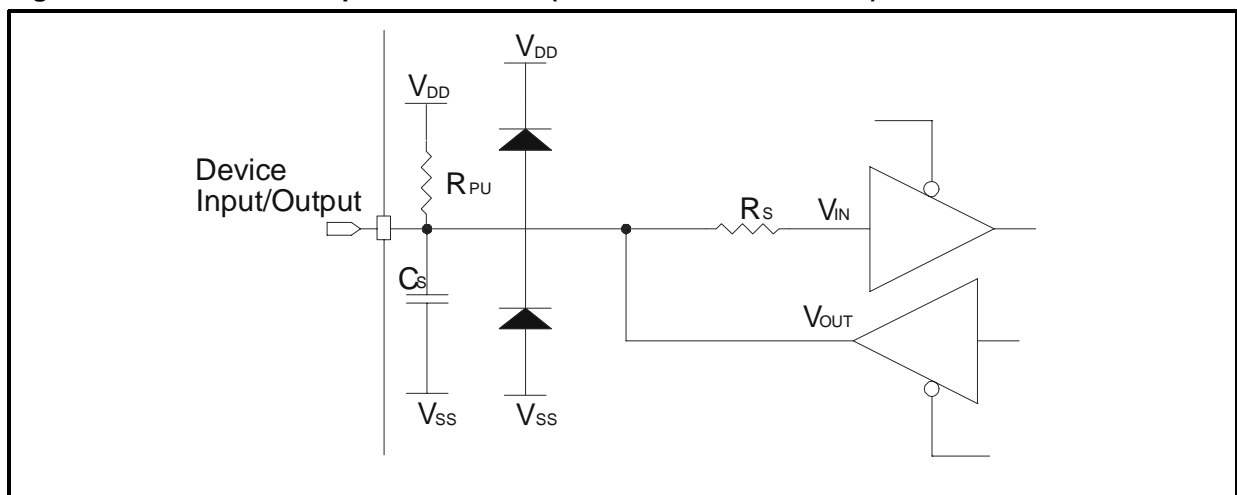

Figure 11.13 Port B Pin Equivalent Circuit (ST52T400 and ST52X440)



When the triac-driver is configured in burst-mode or phase partialization the pull-up in main1 and main2 pins are disabled.

When the Port B pin is configured as analog input the pull-up is disabled.

Figure 11.14 Port A and Port C pin Equivalent Circuit (ST52T441)

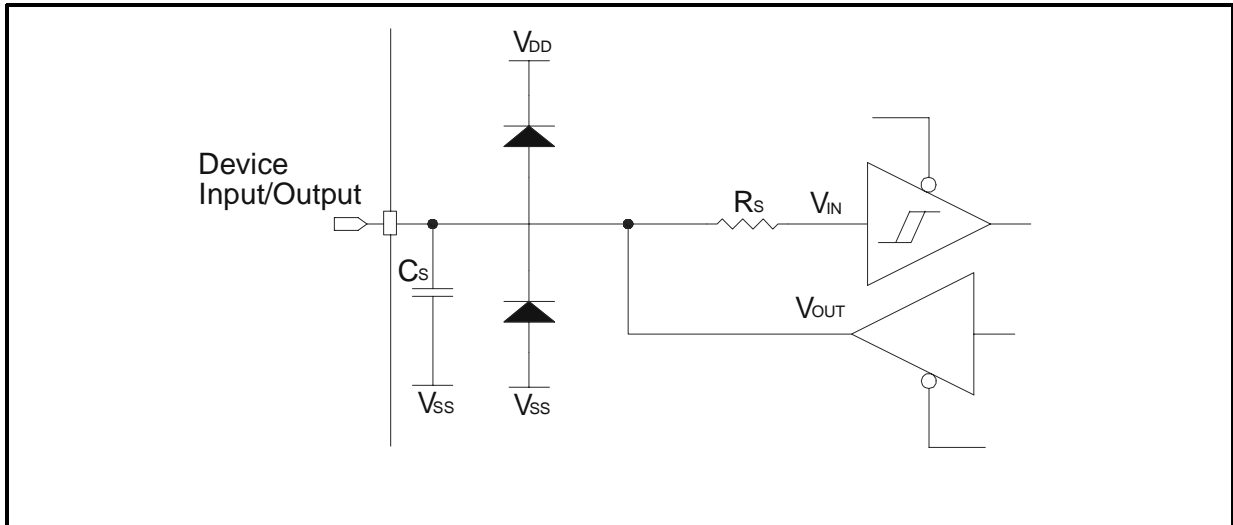
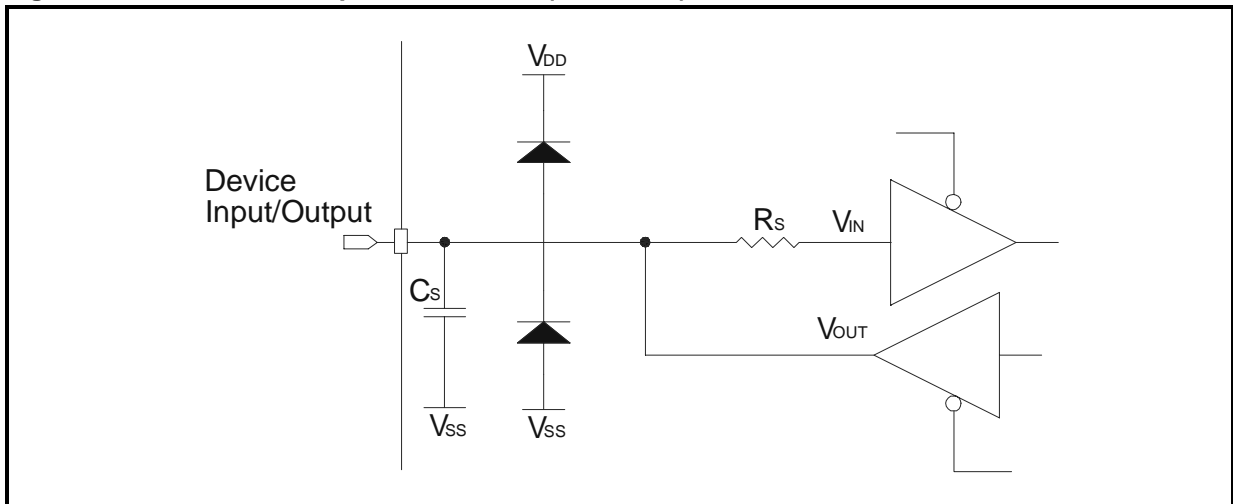

Figure 11.15 Port B Pin Equivalent Circuit (ST52T441)



11.11 Control Pin Characteristics
11.11.1 RESET pin.

Subject to general operating conditions for V_{DD} , f_{osc} , and T_A , unless otherwise specified

Table 11.13 Reset pin

Symbol	Parameter	Conditions	Min	Typ	Max	Unit
V_{IL}	Input low level voltage ¹⁾	$V_{DD}= 5\text{ V}$		2.2 ³⁾		V
V_{IH}	Input high level voltage ¹⁾	$V_{DD}= 5\text{ V}$		2.8 ³⁾		
V_{hys}	Schmitt trigger voltage hysteresis ²⁾	$V_{DD}= 5\text{ V}$		0.6 ³⁾		
t_{FN}	Duration of filtered noise				100	nS
t_{RST}	Reset pulse duration		500			

11.11.2 Power on reset.
Table 11.14 Power on reset

Symbol	Parameter	Conditions	Min	Typ	Max	Unit
POR	Power on reset		2.25	2.30	2.38	V

11.11.3 V_{PP} pin.

Subject to general operating conditions for V_{DD} , f_{osc} , and T_A , unless otherwise specified.

Table 11.15 V_{PP} ⁴⁾ pin

Symbol	Parameter	Conditions	Min	Typ	Max	Unit
V_{IL}	Input low level voltage ³⁾		V_{SS}		0.2	V
V_{IH}	Input high level voltage ³⁾		$V_{DD}-0.1$		12.6	

Notes:

1. Data is based on characterization results, not tested in production.
2. Hysteresis voltage between Schmitt trigger switching level.
Based on characterization results not tested in production.
3. Data is based on design simulation and/or technology characteristics, not tested in production.
4. In working mode V_{PP} must be tied to V_{SS}

11.12 Analog Comparator Characteristics

Operating conditions: $V_{DD} = 5\text{ V}$, $f_{osc} = 0$, $T_A = 90^\circ\text{C}$ unless otherwise specified

Table 11.16 Analog Comparator Characteristics

Symbol	Parameter	Conditions	Min	Typ	Max	Unit
Res	Resolution	A/D Converter mode			8	bit
V_{BG}	Band Gap voltage	PBx in analogic input $I_G=10\mu\text{A}$ $C_S=10\text{nF}$ $f_{osc} = 4\text{ MHz}$		2.52		V
		PBx in analogic input $I_G=10\mu\text{A}$ $C_S=10\text{nF}$ $f_{osc} = 10\text{ MHz}$		2.62		V
		PBx in analogic input $I_G=10\mu\text{A}$ $C_S=10\text{nF}$ $f_{osc} = 20\text{ MHz}$		2.67		V
V_{OFF}	Input offset voltage	Input differential voltage range [-100, +100] mV	1.8	2.4	10	mV
I_{CS}	Capacitor charging current (measured I_G)	$I_G = 10\ \mu\text{A}$ (*)	8.2	9.7	10.5	μA
		$I_G = 20\ \mu\text{A}$ (*)	16.7	19.4	21.6	μA
		$I_G = 40\ \mu\text{A}$ (*)	33.3	38.0	43.3	μA

(*) $f_{osc} = 1, 5, 10, 20\text{ MHz}$, $V_{DD} = 5\text{ V}$, $V_{PBO} = 2\text{ V}$, Resolution = 8 bit, $C_S = 22\text{nF}$, $T_A = 25^\circ\text{C}$.

11.13 Triac Driver Characteristics

Operating conditions: $V_{DD} = 5\text{ V}$, $f_{osc} = 0$, $T_A = 90^\circ\text{C}$

Table 11.17 Triac Driver Characteristics

Symbol	Parameter	Conditions	Min	Typ	Max	Unit
V_{OL}	Output low level voltage when $I_{IO} = 50\text{ mA}$	$V_{DD} = 5\text{ V}$, $I_{IO} = +50\text{ mA}$			$V_{SS} + 0.7$	V
V_{OH}	Output high level voltage when $I_{IO} = 50\text{ mA}$	$V_{DD} = 5\text{ V}$, $I_{IO} = -50\text{ mA}$	$V_{DD} - 0.9$			

Notes:

- The I_{IO} current sunk must always respects the absolute maximum rating specified in Section 11.2 and the sum of I_{IO} (I/O ports and control pins) must not exceed I_{VSS}
- The I_{IO} sourced current must always respect the absolute maximum rating specified in Section 11.2 and the sum of I_{IO} (I/O ports and control pins) must not exceed I_{VDD} .

Table 11.18 S020 PACKAGE MECHANICAL DATA

DIM	mm			inch.		
	MIN	TYP.	MAX	MIN	TYP.	MAX
A	2.35		2.65	0.093		0.104
A1	0.1		0.3	0.004		0.012
B	0.33		0.51	0.013		0.020
C	0.23		0.32	0.009		0.013
D	12.6		13	0.496		0.512
E	7.4		7.6	0.291		0.299
e		1.27			0.050	
H	10		10.65	0.394		0.419
h	0.25		0.75	0.010		0.030
L	0.4		1.27	0.016		0.050
K	0° (min.) 8° (max.)					

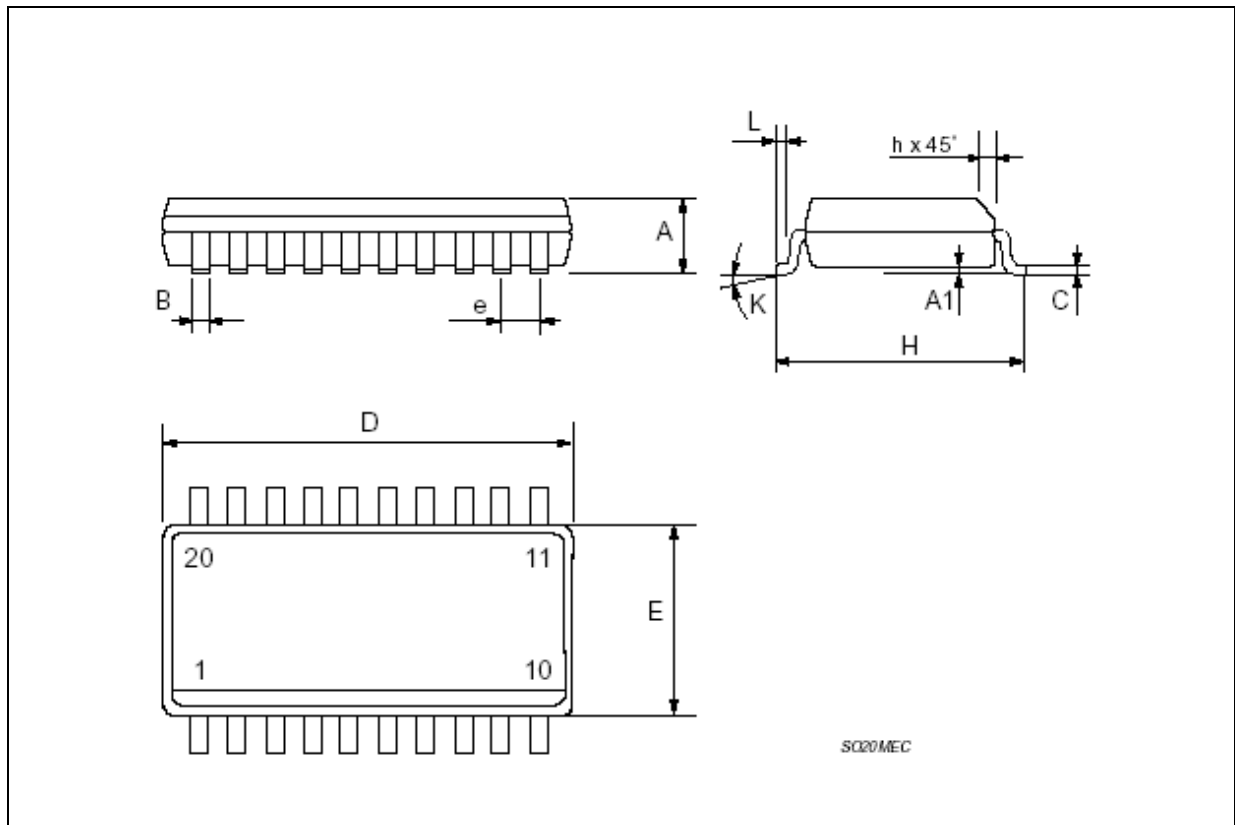

Table 11.19 SOP28 PACKAGE MECHANICAL DATA

DIM	mm			inch.		
	MIN	TYP.	MAX	MIN	TYP.	MAX
A	1.55		1.75	0.061		0.069
a1	0.10		0.25	0.004		0.010
b	0.20		0.30	0.008		0.012
b1	0.18		0.25	0.007		0.010
D	9.80		9.98	0.386		0.393
F	5.79		6.20	0.228		0.244
e		0.64			0.025	
E	3.80		3.98	0.15		0.157
L	0.40		0.90	0.016		0.035
S	8°			8°		

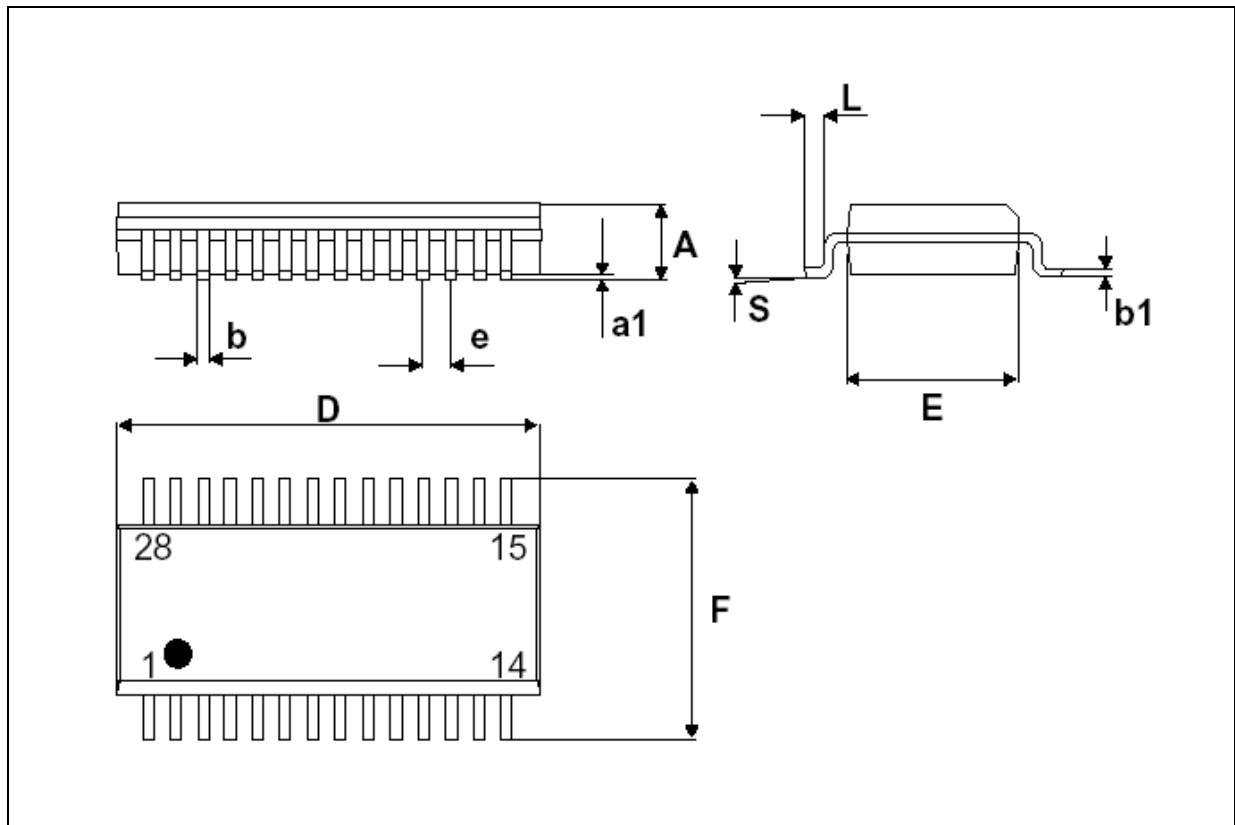

Table 11.20 PDIP28 PACKAGE MECHANICAL DATA

DIM	mm			inch.		
	MIN	TYP.	MAX	MIN	TYP.	MAX
A			5.08			0.200
A1	0.38			0.015		
A2	3.56		4.06	0.140		0.160
B	0.38		0.51	0.015		0.020
B1		1.52			0.060	
C	0.20		0.30	0.008		0.012
D	36.83		37.34	1.450		1.470
D2		33.02			1.300	
E		15.24			0.600	
E1	13.59		13.84	0.535		0.545
e1		2.54			0.100	
eA		14.99			0.590	
eB	15.24		17.78	0.600		0.700
L	3.18		3.43	0.125		0.135
S	1.78		2.08	0.070		0.082
α	0°		10°	0°		10°
N	28			28		

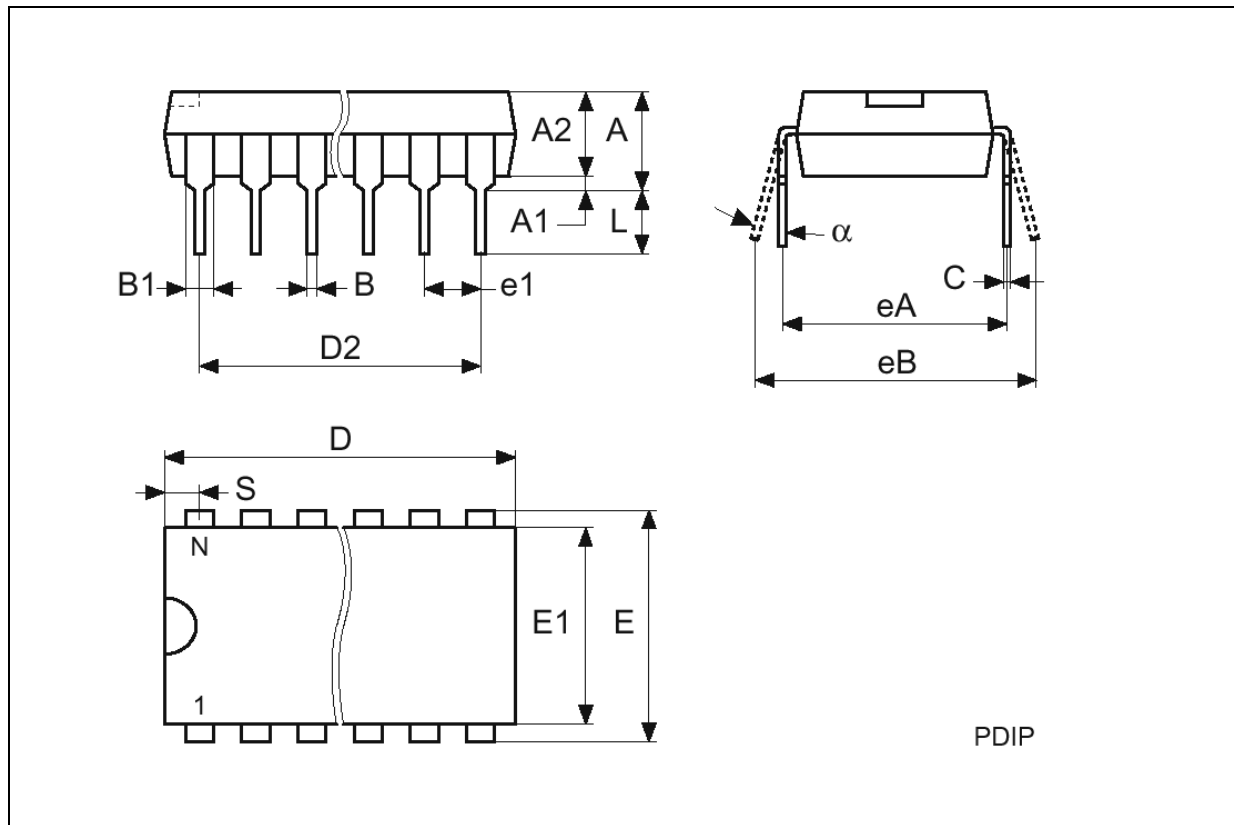

Table 11.21 DIP20 PACKAGE MECHANICAL DATA

DIM	mm			inch.		
	MIN	TYP.	MAX	MIN	TYP.	MAX
a1	0.508			0.020		
B	1.39		1.65	0.055		0.065
b		0.45			0.018	
b1		0.25			0.010	
D			25.4			1.000
E		8.5			0.335	
e		2.54			0.100	
e3		22.86			0.900	
F			7.1			0.279
l			3.93			0.155
L		3.3			0.130	
Z			1.34			0.053

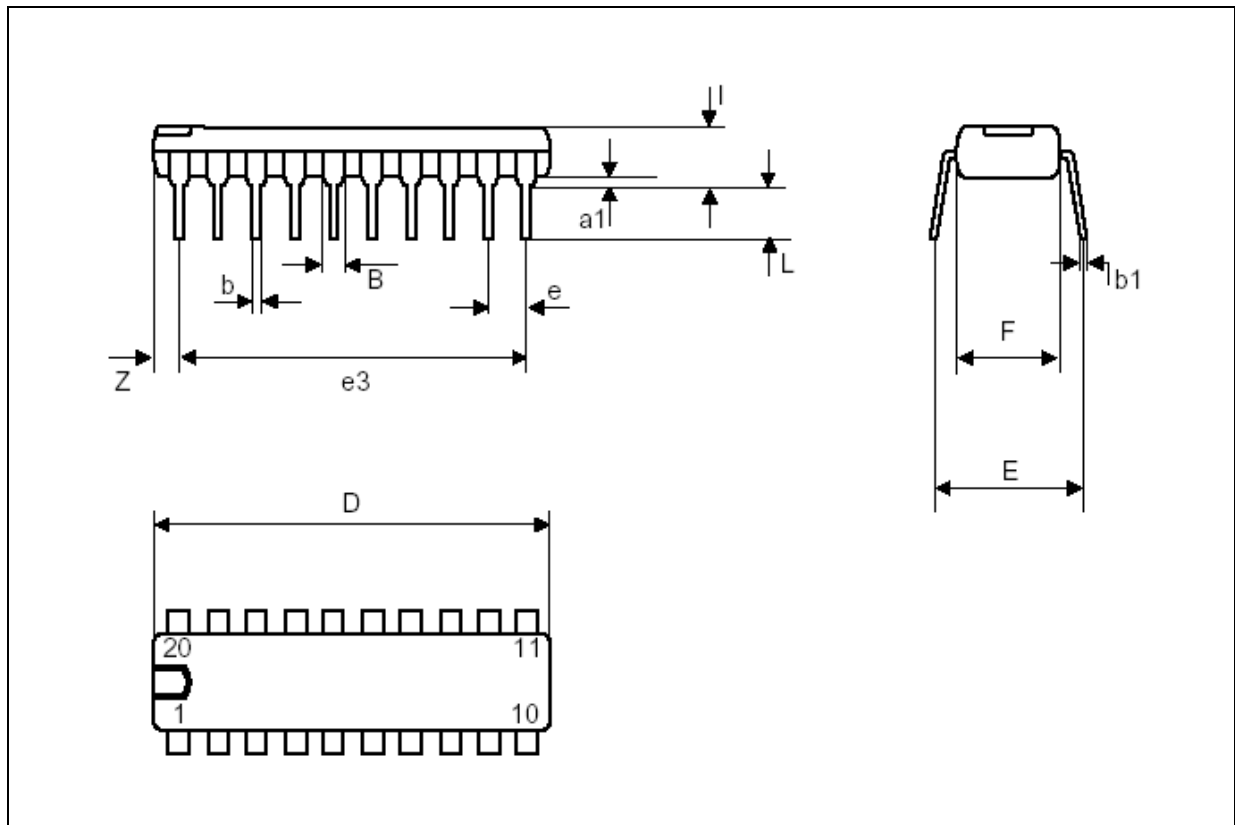

Table 11.22 CDIP28W PACKAGE MECHANICAL DATA

DIM	mm			inch.		
	MIN	TYP.	MAX	MIN	TYP.	MAX
A			5.72			0.225
A1	0.51		1.40	0.020		0.055
A2	3.91		4.57	0.154		0.180
A3	3.89		4.50	0.153		0.177
B	0.41		0.56	0.016		0.022
B1		1.45			0.057	
C	0.23		0.30	0.009		0.012
D	36.50		37.34	1.437		1.470
D2		33.02			1.300	
E		15.24			0.600	
E1	13.06		13.36	0.514		0.526
e		2.54			0.100	
eA		14.99			0.590	
eB	16.18		18.03	0.637		0.710
L	3.18		4.10	0.125		0.161
S	1.52		2.49	0.060		0.098
∅		8.89			0.350	
α	4°		11°	4°		11°
N	28			28		

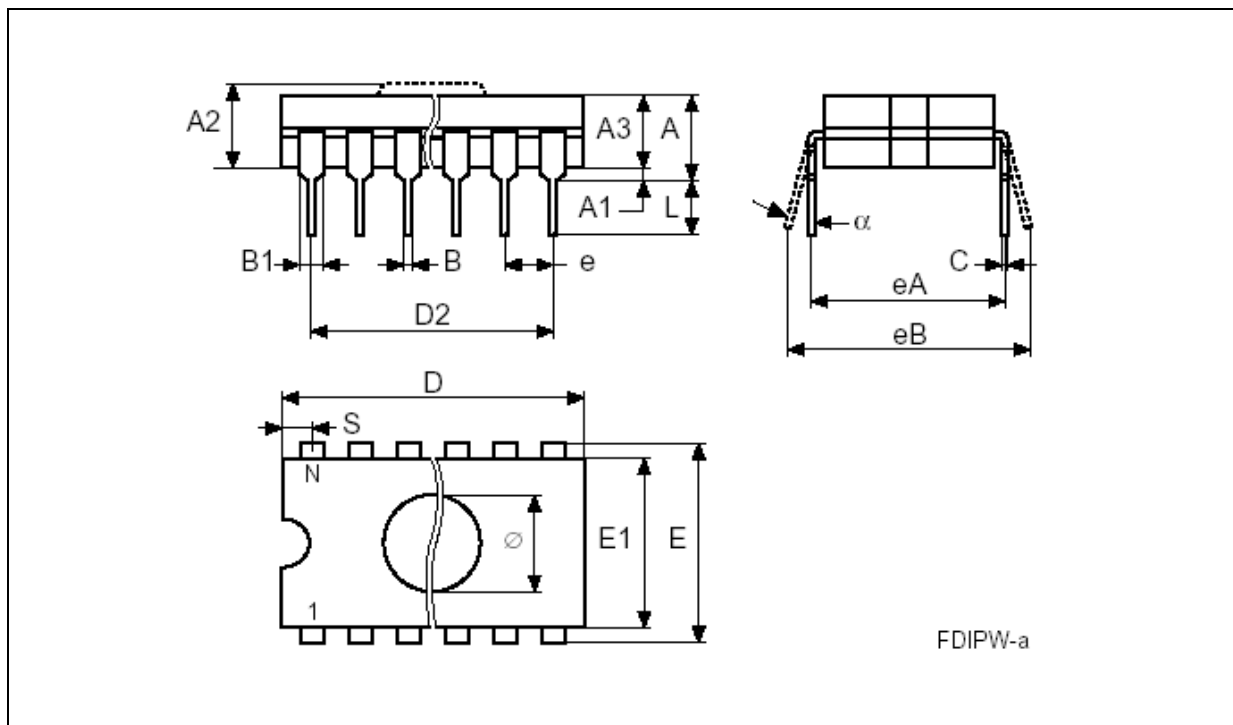
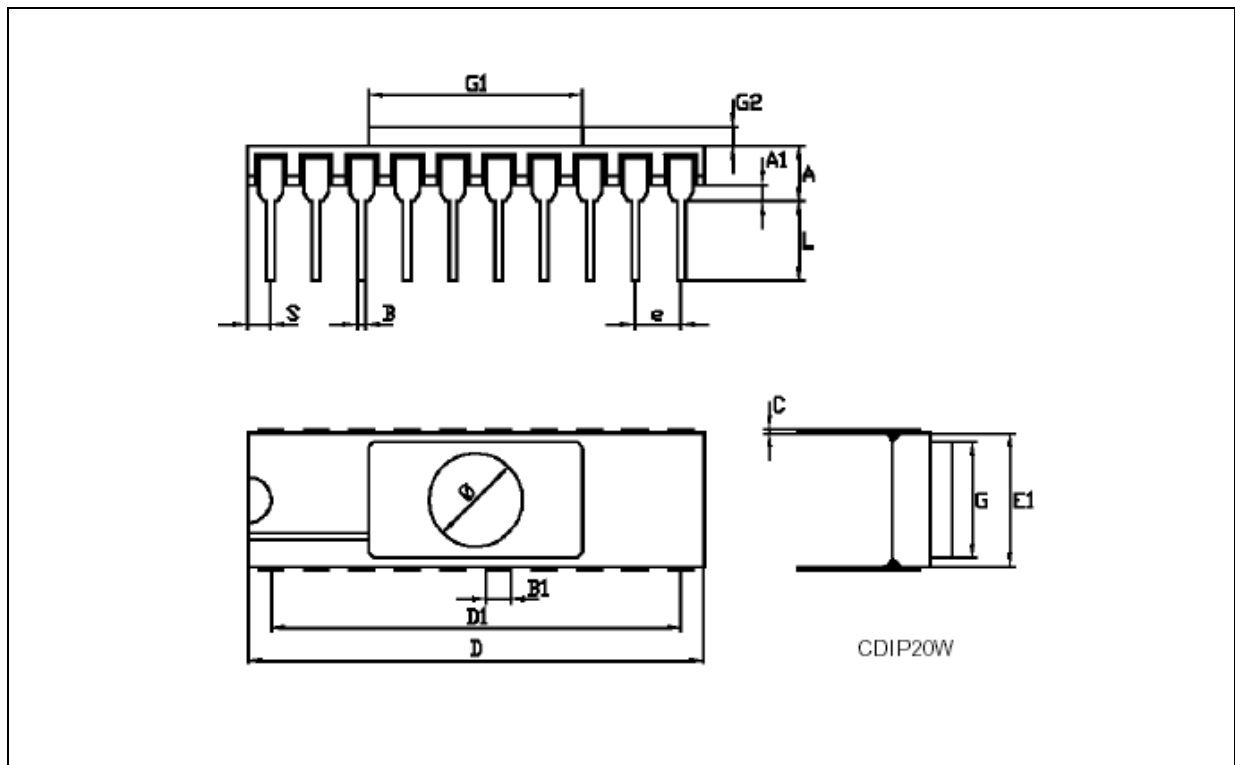

Table 11.23 CDIP20W PACKAGE MECHANICAL DATA

DIM	mm			inch.		
	MIN	TYP.	MAX	MIN	TYP.	MAX
A			3.63			0.143
A1	0.38			0.015		
B	3.56	0.46	0.56	0.140	0.018	0.022
B1	1.14	12.70	1.78	0.045	0.500	0.070
C	0.20	0.25	0.36	0.008	0.010	0.014
D	24.89	25.40	25.91	0.980	1.000	1.020
D1		22.86			0.900	
E1	6.99	7.49	8.00	0.275	0.295	0.315
e		2.54			0.100	
G	6.35	6.60	6.86	0.250	0.260	0.270
G1	9.47	9.73	9.98	0.373	0.383	0.393
G2		1.14			0.045	
L	2.92	3.30	3.81	0.115	0.130	0.150
S		12.70			0.500	
∅		4.22			0.166	
N	20					



ST52T400/T440/E440/T441

ORDERING INFORMATION

Each device is available for production in user programmable version (OTP) as well as in factory programmed version (FASTROM). OTP devices are shipped to customers with a default blank content FFh, while FASTROM factory programmed parts contain the code sent by the customer. There is one common EPROM version for debug-

ging and prototyping which features the maximum memory size and peripherals of the family. Care must be taken to only use resources available on the target device. In order to obtain a list of part numbers see **ST52T400/T440/E440/T441 Sales Type List** at the beginning of the datasheet.

Figure 11.16 Device Type Codes

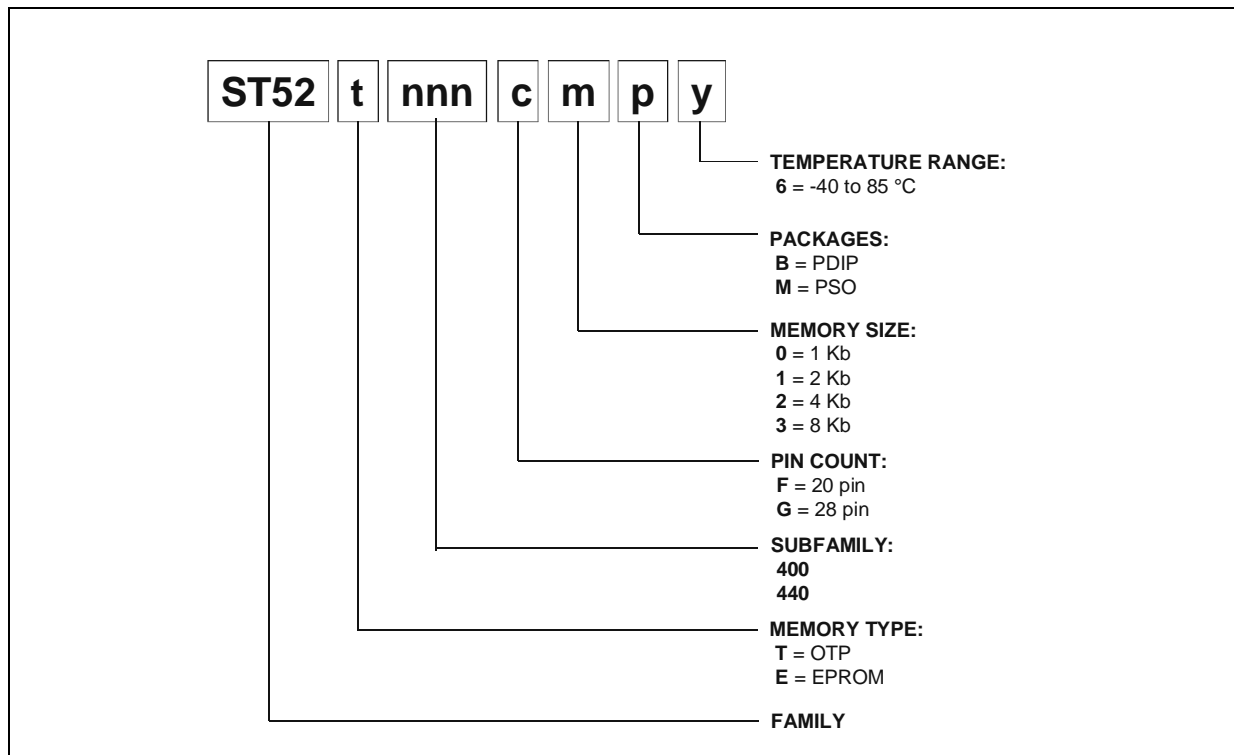

Full Product Information at <http://www.st.com/five>

Information furnished is believed to be accurate and reliable. However, STMicroelectronics assumes no responsibility for the consequences of use of such information nor for any infringement of patents or other rights of third parties which may result from its use. No license is granted by implication or otherwise under any patent or patent rights of STMicroelectronics. Specification mentioned in this publication are subject to change without notice. This publication supersedes and replaces all information previously supplied. STMicroelectronics products are not authorized for use as critical components in life support devices or systems without express written approval of STMicroelectronics.

The ST logo is a registered trademark of STMicroelectronics

© 2002 STMicroelectronics – Printed in Italy – All Rights Reserved

STMicroelectronics GROUP OF COMPANIES

Australia - Brazil - China - Canada - Finland - France - Germany - Hong Kong - India - Israel - Italy - Japan - Malaysia - Malta
- Morocco - Singapore - Spain - Sweden - Switzerland - United Kingdom - U.S.A.

<http://www.st.com>