

4.9 - 6 GHz 29dBm Single-Bias MMIC

FEATURES

- P₋₁ dB: 29 dBm
- Small Signal Gain: 21 dB
- Power Added Efficiency: 25 %
- IP3: 39 dBm
- Match to 50 Ω operation
- Bias condition: 400 mA @ 8 V

PHOTO ENLARGEMENT



DESCRIPTION

The TC3532 is a 2-stage PHEMT MMIC power amplifier with single-bias. It requires only a single positive supply. It is designed for use in low cost and high volume 4.9~6 GHz band applications. The MMIC is matched to 50Ω operation. No external matching component is required. It provides a typical gain of 21 dB and P_{1dB} power of 29 dBm. Typical bias condition is 8V at 400 mA. The MMIC is packaged in a Ceramic 10 Pins package. The copper based carrier of the package allows direct soldering of the device to the PCB.

APPLICATIONS

- Wireless Internet Access

ELECTRICAL SPECIFICATIONS (Ta = 25 °C)

SYMBOL	DESCRIPTION	MIN	TYP	MAX	UNITS
FREQ	Frequency Range	4.9		6	GHz
SSG	Small Signal Gain	19	21		dB
GOF	Small Signal Gain Flatness		±0.5		dB
P₋₁ dB	Output Power at 1 dB Gain Compression	28	29		dBm
P₋₃ dB	Output Power at 3 dB Gain Compression	29	30		dBm
IP3	Third Order Intercept Point	37	39		dBm
VSWR, IN	Input VSWR		2:1		
VDD	Supply Voltage		8		Volt
IDD	Current Supply Without RF		400		mA
IDP₋₁	Current Supply @ P _{out} =P ₋₁ dB		420		mA
η_a	Power Added Efficiency		25		%

TEST CIRCUITS

Evaluation Board Schematic

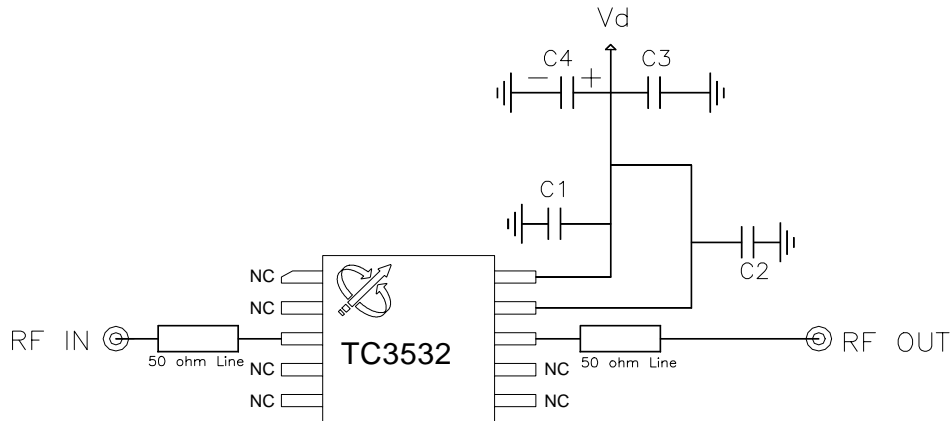

EVALUATION BOARD
PCB Material: RO4003
ER = 3.38
Thickness = 20 mil
Unit: mil

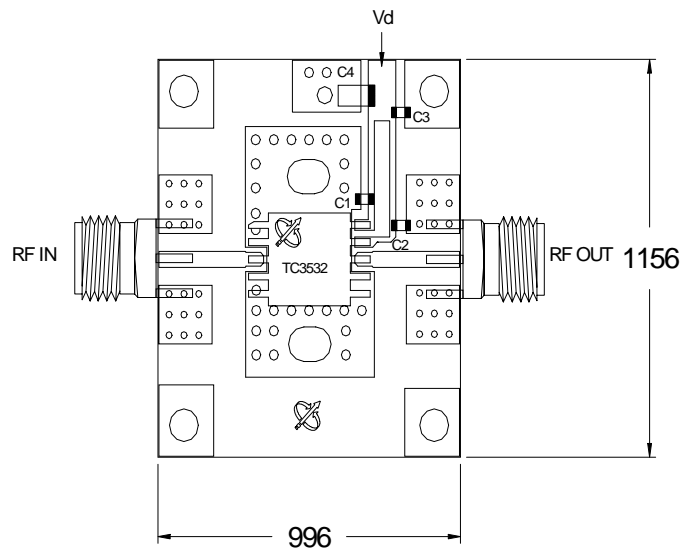
- DXF file of the PCB can be downloaded from our web-site at www.transcominc.com.tw
- **Application Notes:**
For better heat sinking and grounding, it's recommended to have the via holes beneath TC3532 filled with solder and have two screws besides TC3532 installed on the PCB area.

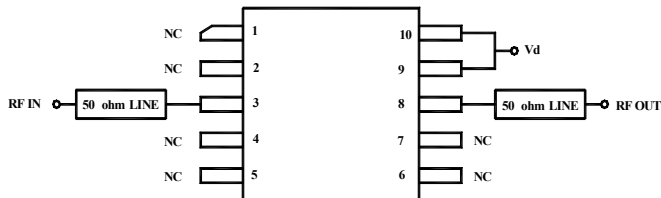

Evaluation Board Parts List

Part Type	Reference Designator	Description	Manufacturer	Part Number
Capacitor	C1, C2	0.1 uF 0603	Murata	GRM39Y5V104Z25V
Capacitor	C3	1000pF 0603	Murata	GRM39C0G102J50V
Capacitor	C4	4.7uF Tantalum Cap.		

CONNECTION DIAGRAM AND PIN DESCRIPTIONS

Pin #	Name	Description
3	RF IN	RF input
9, 10	Vd	MMIC Drain bias
8	RF OUT	RF output (internally DC blocked)
Others	NC	No Connection

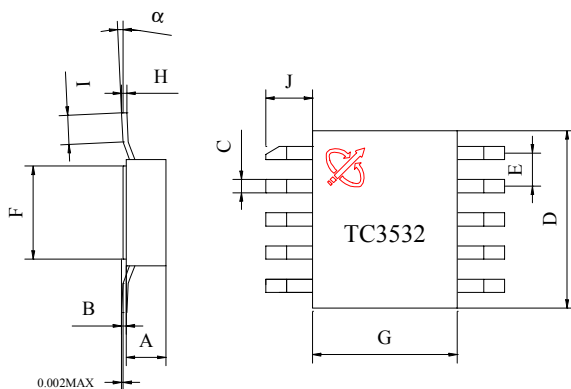
PHYSICAL DIMENSIONS (Unit: inch)

DIMENSION	MINIMUM	NOMINAL	MAXIMUM
A	0.054	0.057	0.060
B	0.007	0.008	0.009
C	0.017	0.020	0.023
D	0.267	0.270	0.273
E	0.047	0.050	0.053
F	0.247	0.250	0.253
G	0.267	0.270	0.273
H	0.007	0.008	0.009
I	0.020		0.040
J	0.073	0.080	0.087
α	0°		7°