

## 2-WIRE SERIAL TEMPERATURE SENSOR AND THERMAL MONITOR

### FEATURES

- Solid State Temperature Sensing; 2°C Accuracy (Typ.)
- Operates from – 55°C to +125°C
- Operating Range ..... 2.7V - 5.5V
- Programmable Trip Point and Hysteresis with Power-up Defaults
- Standard 2-Wire Serial Interface
- Thermal Event Alarm Output Functions as Interrupt or Comparator / Thermostat Output
- Up to 8 TCN75's May Share the Same Bus
- Shutdown Mode for Low Standby Power Consumption
- Low Power ..... 250µA (Typ.) Operating  
1µA (Typ.) Shutdown Mode
- 8-Pin Plastic DIP, SOIC, and MSOP Packaging

### TYPICAL APPLICATIONS

- Thermal Protection for High Performance CPU's
- Solid-State Thermometer
- Fire/Heat Alarms
- Thermal Management in Electronic Systems:
  - Computers
  - Telecom Racks
  - Power Supplies / UPS\* / Amplifiers
- Copiers / Office Electronics
- Consumer Electronics
- Process Control

### GENERAL DESCRIPTION

The TCN75 is a serially programmable temperature sensor that notifies the host controller when ambient tem-

perature exceeds a user-programmed setpoint. Hysteresis is also programmable. The INT/CMPTTR output is programmable as either a simple comparator for thermostat operation or as a temperature event interrupt. Communication with the TCN75 is accomplished via a two-wire bus that is compatible with industry standard protocols. This permits reading the current temperature, programming the setpoint and hysteresis, and configuring the device.

The TCN75 powers up in Comparator Mode with a default setpoint of 80°C with 5°C hysteresis. Defaults allow independent operation as a stand-alone thermostat. A shutdown command may be sent via the 2-wire bus to activate the low-power standby mode. Address selection inputs allow up to eight TCN75's to share the same 2-wire bus for multi-zone monitoring.

All registers can be read by the host and the INT/CMPTTR output's polarity is user programmable. Both polled and interrupt driven systems are easily accommodated. Small physical size, low installed cost, and ease of use make the TCN75 an ideal choice for implementing sophisticated system management schemes.

### ORDERING INFORMATION

Part No.	Supply Voltage (V)	Package	Junction Temp. Range
TCN75-3.3MOA	3.3	8-Pin SOIC	– 55°C to +125°C
TCN75-5.0MOA	5.0	8-Pin SOIC	– 55°C to +125°C
TCN75-3.3MPA	3.3	8-Pin PDIP	– 55°C to +125°C
TCN75-5.0MPA	5.0	8-Pin PDIP	– 55°C to +125°C
TCN75-3.3MUA	3.3	8-MSOP	– 55°C to +125°C
TCN75-5.0MUA	5.0	8-MSOP	– 55°C to +125°C

### FUNCTIONAL BLOCK DIAGRAM

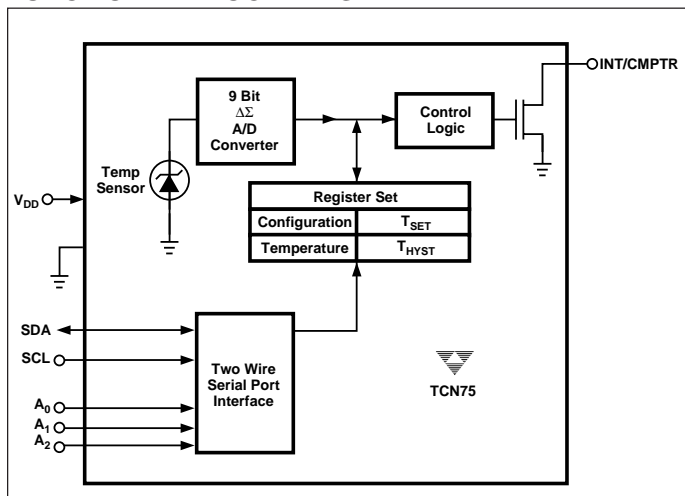

### PIN CONFIGURATIONS

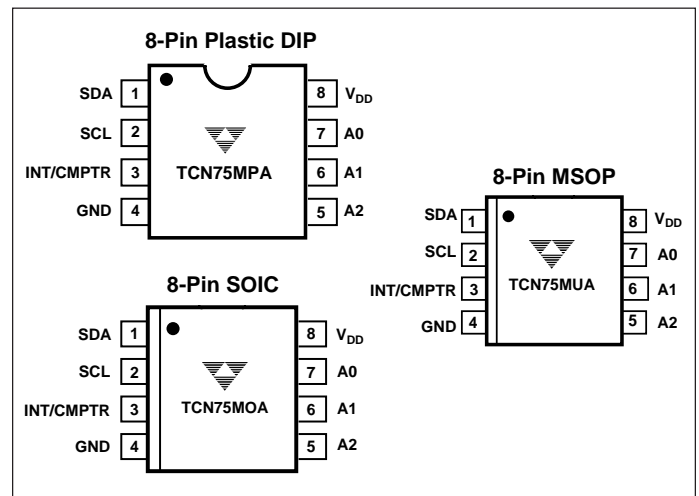

## TCN75

## ABSOLUTE MAXIMUM RATINGS\*

Supply Voltage ( $V_{DD}$ )	6.0V
ESD Susceptibility (Note 2)	(TBD)
Voltage on Any Pin	(GND – 0.3V) to ( $V_{DD} + 0.3V$ )
Operating Temperature Range ( $T_J$ )	– 55°C to +125°C
Storage Temperature Range ( $T_{STG}$ )	– 65°C to +150°C

Lead Temperature (Soldering, 10 sec)	+300°C
Thermal Resistance (Junction to Ambient)	
8-Pin DIP	110°C/W
8-Pin SOIC	170°C/W
8-Pin MSOP	250°C/W

\*This is a stress rating only and functional operation of this device at these or any other conditions above those indicated in the operations sections of this specification is not implied.

**ELECTRICAL CHARACTERISTICS:**  $V_{DD} = 2.7V - 5.5V$ ,  $-55^\circ C \leq (T_A = T_J) \leq 125^\circ C$ , unless otherwise noted.

Symbol	Parameter	Test Conditions	Min	Typ	Max	Unit
<b>Power Supply</b>						
$V_{DD}$	Power Supply Voltage		2.7	—	5.5	V
$I_{DD}$	Operating Current	Serial Port Inactive ( $T_A = T_J = 25^\circ C$ ) Serial Port Active	— —	0.250 —	— 1.0	mA
$I_{DD1}$	Standby Supply Current	Shutdown Mode, Serial Port Inactive ( $T_A = T_J = 25^\circ C$ )	—	1	—	$\mu A$
<b>INT/CMPTR Output</b>						
$I_{OL}$	Sink Current: INT/CMPTR, SDA Outputs	Note 1	—	1	4	mA
$t_{TRIP}$	INT/CMPTR Response Time	User Programmable	1	—	6	$t_{CONV}$
$V_{OL}$	Output Low Voltage	$I_{OL} = 4.0mA$	—	—	0.8	V
<b>Temp-to-Bits Converter</b>						
$\Delta T$	Temperature Accuracy (Note 2)	$-55^\circ C \leq T_A \leq +125^\circ C$ $V_{DD} = 3.3V$ : TCN75-3.3MOA, TCN75-3.3MPA, TCN75-3.3MUA $V_{DD} = 5.0V$ : TCN75-5.0MOA, TCN75-5.0MPA, TCN75-5.0 MUA $25^\circ C \leq T_A \leq 100^\circ C$	— —	$\pm 3$ $\pm 0.5$	— $\pm 2$	$^\circ C$ $^\circ C$
$t_{CONV}$	Conversion Time		—	100	—	msec
$T_{SET(PU)}$	TEMP Default Value	Power Up	—	80	—	$^\circ C$
$T_{HYST(PU)}$	THYST Default Value	Power Up	—	75	—	$^\circ C$
<b>2-Wire Serial Bus Interface</b>						
$V_{IH}$	Logic Input High		$V_{DD} \times 0.7$	—	—	V
$V_{IL}$	Logic Input Low		—	—	$V_{DD} \times 0.3$	V
$V_{OL}$	Logic Output Low	$I_{OL} = 3mA$	—	—	0.4	V
$C_{IN}$	Input Capacitance SDA, SCL		—	15	—	pF
$I_{LEAK}$	I/O Leakage	( $T_A = T_J = 25^\circ C$ )	—	$\pm 100$	—	pA
$I_{OL(SDA)}$	SDA Output Low Current		—	—	6	mA

**SERIAL PORT TIMING:**  $2.7V \leq V_{DD} \leq 5.5V$ ;  $-55^\circ C \leq (T_A = T_J) \leq 125^\circ C$ ,  $C_L = 80pf$ , unless otherwise noted.

Symbol	Parameter	Test Conditions	Min	Typ	Max	Unit
$f_{SC}$	Serial Port Frequency		0	100	400	kHz
$t_{LOW}$	Low Clock Period		1250	—	—	nsec
$t_{HIGH}$	High Clock Period		1250	—	—	nsec
$t_R$	SCL and SDA Rise Time		—	—	250	nsec
$t_F$	SCL and SDA Fall Time		—	—	250	nsec
$t_{SU(START)}$	Start Condition Setup Time (for repeated Start Condition)		1250	—	—	nsec

**SERIAL PORT TIMING (Cont.):**  $2.7V \leq V_{DD} \leq 5.5V$ ;  $-55^{\circ}C \leq (T_A = T_J) \leq 125^{\circ}C$ ,  $C_L = 80pf$ , unless otherwise noted.

Symbol	Parameter	Test Conditions	Min	Typ	Max	Unit
$t_{H(START)}$	Start Condition Hold Time		1250	—	—	nsec
$t_{DSU}$	Data in Setup Time to SCL High		100	—	—	nsec
$t_{DH}$	Data in Hold Time after SCL Low		0	—	—	nsec
$t_{SU(STOP)}$	Stop Condition Setup Time		1250	—	—	nsec
$t_{IDLE}$	Bus Free Time Prior to New Transition		1250	—	—	nsec

- NOTES:**
1. Output current should be minimized for best temperature accuracy. Power dissipation within the TCN75 will cause self-heating and temperature drift. At maximum rated output current and saturation voltage, 4mA and 0.8V, respectively, the error amounts to 0.352°C for the PDIP, and 0.544°C for the SOIC.
  2. All part types of the TCN75 will operate properly over the wider power supply range of 2.7V to 5.5V. Each part type is tested and specified for rated accuracy at its nominal supply voltage. As  $V_{DD}$  varies from the nominal value, accuracy will degrade 1°C/V of  $V_{DD}$  change.
  3. Human body model, 100pF discharged through a 1.5k resistor, machine model, 200pF discharged directly into each pin.

## PIN DESCRIPTION

Pin Number	Symbol	Description
1	SDA	Bidirectional Serial Data.
2	SCL	Serial Data Clock Input.
3	INT/CMPTR	Interrupt or Comparator Output.
4	GND	System Ground.
5	A <sub>2</sub>	Address Select Pin (MSB).
6	A <sub>1</sub>	Address Select Pin.
7	A <sub>0</sub>	Address Select Pin (LSB).
8	V <sub>DD</sub>	Power Supply Input.

## DETAILED DESCRIPTION

A typical TCN75 hardware connection is shown in Figure 1.

### Serial Data (SDA)

Bidirectional. Serial data is transferred in both directions using this pin.

### Serial Clock (SCL)

Input. Clocks data into and out of the TCN75.

### INT/CMPTR

Open Collector, Programmable Polarity. In Comparator Mode, unconditionally driven active any time temperature exceeds the value programmed into the T<sub>SET</sub> register. INT/CMPTR will become inactive when temperature subsequently falls below the T<sub>HYST</sub> setting. (See *Register Set and Programmer's Model*.) In Interrupt Mode, INT/CMPTR is also made active by TEMP exceeding T<sub>SET</sub>; it is unconditionally reset to its inactive state by reading any register via the 2-wire bus. If and when temperature falls below T<sub>HYST</sub>, INT/CMPTR is again driven active. Reading any register will clear the T<sub>HYST</sub> interrupt. In Interrupt Mode, the INT/CMPTR

output is unconditionally reset upon entering Shutdown Mode. If programmed as an active-low output, it can be wire-ORed with any number of other open collector devices. Most systems will require a pull-up resistor for this configuration.

Note that current sourced from the pull-up resistor causes power dissipation and may cause internal heating of the TCN75. To avoid affecting the accuracy of ambient temperature readings, the pull-up resistor should be made as large as possible. INT/CMPTR's output polarity may be programmed by writing to the INT/CMPTR POLARITY bit in the CONFIG register. The default is active low.

### Address (A<sub>2</sub>, A<sub>1</sub>, A<sub>0</sub>)

Inputs. Sets the three least significant bits of the TCN75 8-bit address. A match between the TCN75's address and the address specified in the serial bit stream must be made to initiate communication with the TCN75. Many protocol-compatible devices with other addresses may share the same 2-wire bus.

### Slave Address

The four most significant bits of the Address Byte (A<sub>6</sub>, A<sub>5</sub>, A<sub>4</sub>, A<sub>3</sub>) are fixed to 1001[B]. The states of A<sub>2</sub>, A<sub>1</sub> and

## TCN75

A0 in the serial bit stream must match the states of the A2, A1 and A0 address inputs for the TCN75 to respond with an Acknowledge (indicating the TCN75 is on the bus and ready to accept data). The Slave Address is represented by:

### TCN75 Slave Address

1	0	0	1	A2	A1	A0
MSB						LSB

### Comparator/Interrupt Modes

INT/CMPTR behaves differently depending on whether the TCN75 is in Comparator Mode or Interrupt Mode. Comparator Mode is designed for simple thermostatic operation. INT/CMPTR will go active anytime TEMP exceeds  $T_{SET}$ . When in Comparator Mode, INT/CMPTR will remain active until TEMP falls below  $T_{HYST}$ , whereupon it will reset to its inactive state. The state of INT/CMPTR is maintained in shutdown mode when the TCN75 is in comparator mode. In Interrupt Mode, INT/CMPTR will remain active indefinitely, even if TEMP falls below  $T_{HYST}$ , until any register is read via the 2-wire bus. Interrupt Mode is better suited to interrupt driven microprocessor-based systems. The INT/CMPTR output may be wire-OR'ed with other interrupt sources in such systems. Note that a pull-up resistor is necessary on this pin since it is an open-drain output. Entering Shutdown Mode will unconditionally reset INT/CMPTR when in Interrupt Mode.

### SHUTDOWN MODE

When the appropriate bit is set in the configuration register (CONFIG) the TCN75 enters its low-power shutdown mode ( $I_{DD} = 1\mu A$ , typical) and the temperature-to-digital conversion process is halted. The TCN75's bus interface remains active and TEMP,  $T_{SET}$ , and  $T_{HYST}$  may be read from and written to. Transitions on SDA or SCL due to external bus activity may increase the standby power consumption. If the TCN75 is in Interrupt Mode, the state of INT/CMPTR will be RESET upon entering shutdown mode.

### Fault Queue

To lessen the probability of spurious activation of INT/CMPTR the TCN75 may be programmed to filter out transient events. This is done by programming the desired value into the Fault Queue. Logic inside the TCN75 will prevent the device from triggering INT/CMPTR unless the programmed number of sequential temperature-to-digital conversions yield the same qualitative result. In other words, the value reported in TEMP must remain above  $T_{SET}$  or below  $T_{HYST}$  for the consecutive number of cycles programmed in the Fault Queue. Up to a six-cycle "filter" may be selected. See *Register Set and Programmer's Model*.

### Serial Port Operation

The Serial Clock input (SCL) and bidirectional data port (SDA) form a 2-wire bidirectional serial port for programming and interrogating the TCN75. The following conventions are used in this bus scheme:

### TCN75 Serial Bus Conventions

Term	Explanation
Transmitter	The device sending data to the bus.
Receiver	The device receiving data from the bus.
Master	The device which controls the bus: initiating transfers (START), generating the clock, and terminating transfers (STOP).
Slave	The device addressed by the master.
Start	A unique condition signaling the beginning of a transfer indicated by SDA falling (High-Low) while SCL is high.
Stop	A unique condition signaling the end of a transfer indicated by SDA rising (Low - High) while SCL is high.
ACK	A Receiver acknowledges the receipt of each byte with this unique condition. The Receiver drives SDA low during SCL high of the ACK clock-pulse. The Master provides the clock pulse for the ACK cycle.
NOT Busy	When the bus is idle, both SDA & SCL will remain high.
Data Valid	The state of SDA must remain stable during the High period of SCL in order for a data bit to be considered valid. SDA only changes state while SCL is low during normal data transfers. (See Start and Stop conditions)

All transfers take place under control of a host, usually a CPU or microcontroller, acting as the Master, which provides the clock signal for all transfers. The TCN75 *always* operates as a Slave. This serial protocol is illustrated in Figure 2. All data transfers have two phases; and all bytes are transferred MSB first. Accesses are initiated by a start condition (START), followed by a device address byte and one or more data bytes. The device address byte includes a Read/Write selection bit. Each access must be terminated by a Stop Condition (STOP). A convention called *Acknowledge* (ACK) confirms receipt of each byte. Note that SDA can change only during periods when SCL is LOW (SDA changes while SCL is HIGH are reserved for Start and Stop Conditions).

### Start Condition (START)

The TCN75 continuously monitors the SDA and SCL lines for a start condition (a HIGH to LOW transition of SDA while SCL is HIGH), and will not respond until this condition is met.

### Address Byte

Immediately following the Start Condition, the host must next transmit the address byte to the TCN75. The four most significant bits of the Address Byte (A6, A5, A4, A3) are fixed to 1001(B). The states of A2, A1 and A0 in the serial bit stream must match the states of the A2, A1 and A0 address inputs for the TCN75 to respond with an Acknowledge (indicating the TCN75 is on the bus and ready to accept data). The eighth bit in the Address Byte is a Read-Write Bit. This bit is a 1 for a read operation or 0 for a write operation.

### Acknowledge (ACK)

Acknowledge (ACK) provides a positive handshake between the host and the TCN75. The host releases SDA after transmitting eight bits then generates a ninth clock cycle to allow the TCN75 to pull the SDA line LOW to acknowledge that it successfully received the previous eight bits of data or address.

### Data Byte

After a successful ACK of the address byte, the host must next transmit the data byte to be written or clock out the data to be read. (See the appropriate timing diagrams.) ACK will be generated after a successful write of a data byte into the TCN75.

### Stop Condition (STOP)

Communications must be terminated by a stop condition (a LOW to HIGH transition of SDA while SCL is HIGH). The Stop Condition must be communicated by the transmitter to the TCN75.

### Power Supply

To minimize temperature measurement error, the TCN75VO\_-3 is factory calibrated at a supply voltage of  $3.3V \pm 5V$  and the TCN75CO\_-5 is factory calibrated at a supply voltage of  $5V \pm 5\%$ . Either device is fully operational

over the power supply voltage range of 2.7V to 5.5V, but with a lower measurement accuracy. Figure 2 shows the worst case temperature measurement error for the TCN75CO\_-3 operated at a power supply voltage of  $5V \pm 10\%$ . Figure 3 shows the worst case temperature measurement error for the TCN75CO\_-3 operated at a power supply voltage of  $3.3V \pm 10\%$ .

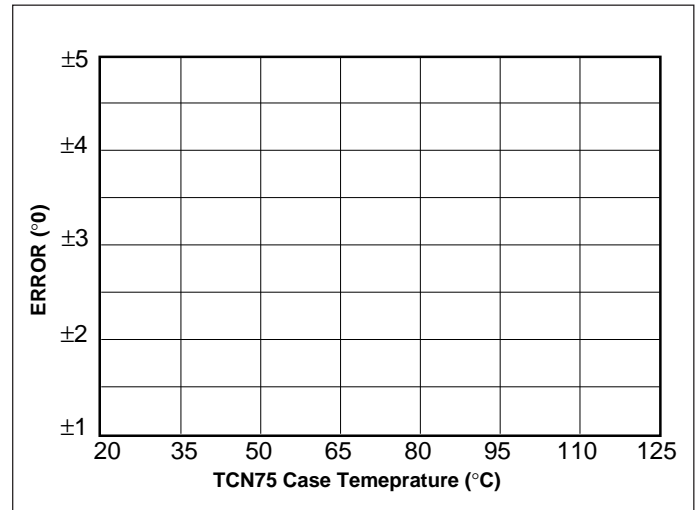

Figure 2. TCN75CO\_-3 Measurement Error at  $V_{DD} = 5V \pm 10\%$

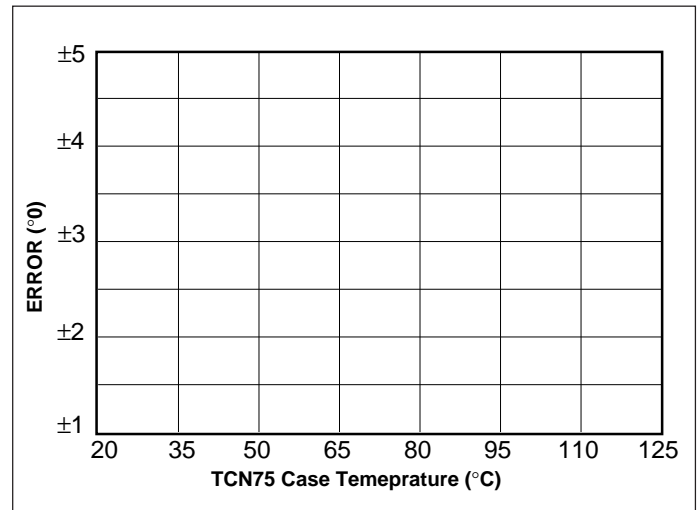

Figure 3. TCN75CO\_-5 Measurement Error at  $V_{DD} = 3.3V \pm 10\%$

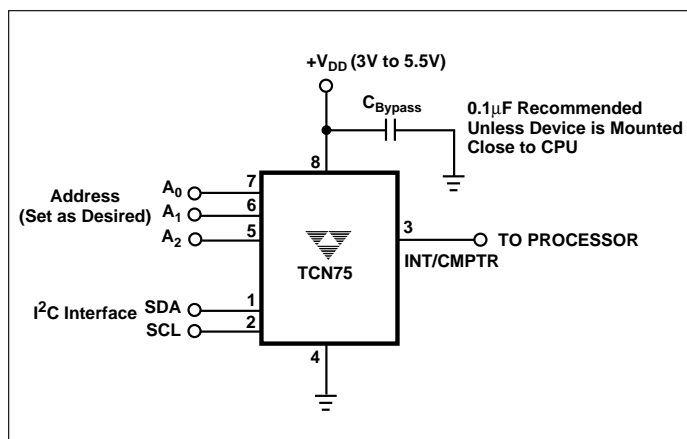

Figure 1. Typical Application

TCN75

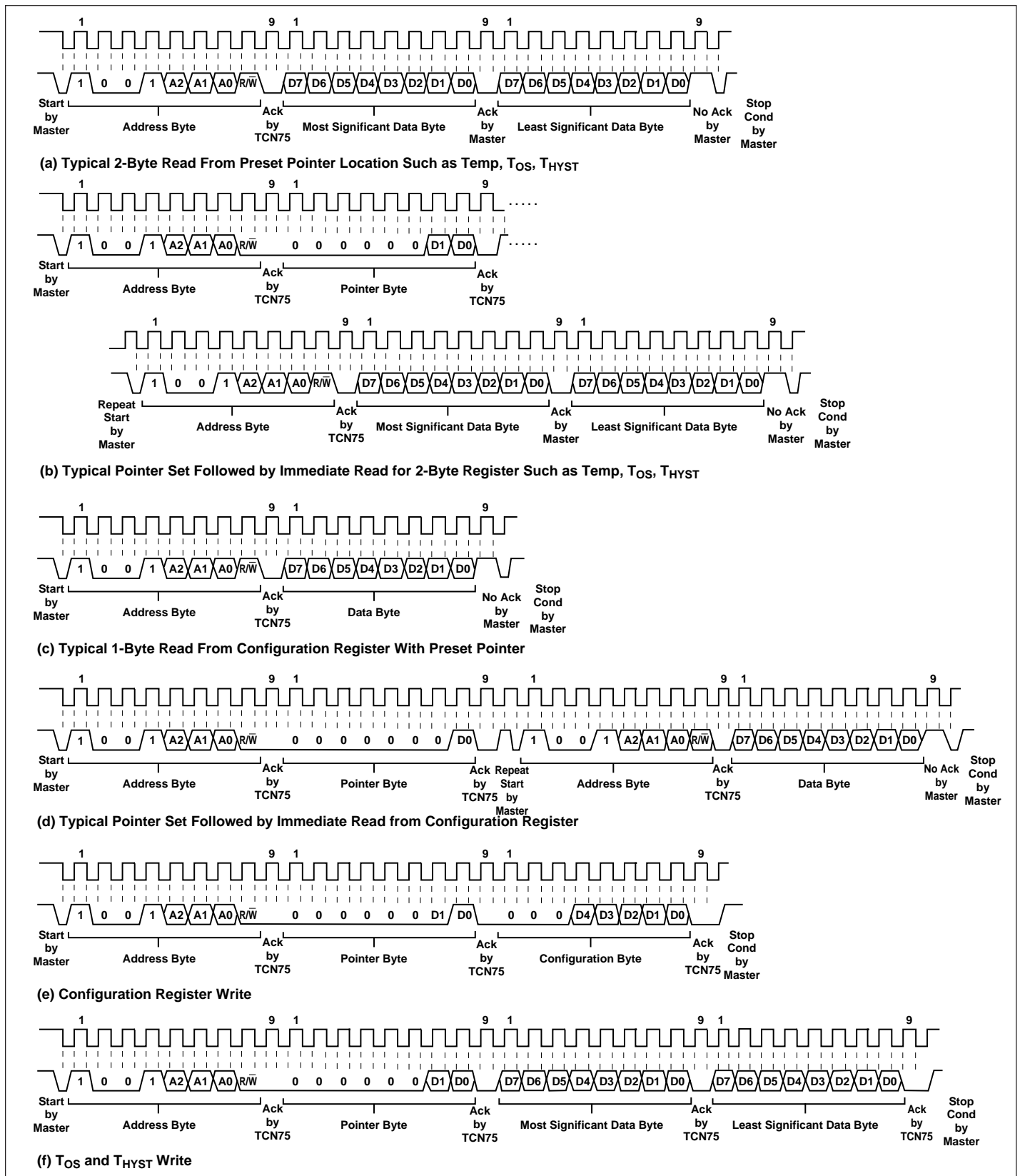

Figure 2. Timing Diagrams

**REGISTER SET AND PROGRAMMER'S MODEL**

**Register (POINT), 8-bits, Write-only**

**Pointer Register (POINT)**

D[7]	D[6]	D[5]	D[4]	D[3]	D[2]	D[1]	D[0]
Must Be Set To Zero						Pointer	

**Register Selection via the Pointer Register:**

D1	D0	Register Selection
0	0	TEMP
0	1	CONFIG
1	0	T <sub>HYST</sub>
1	1	T <sub>SET</sub>

**Configuration Register (CONFIG), 8-bits,  
Read/Write**

**Configuration Register (CONFIG)**

D[7]	D[6]	D[5]	D[4]	D[3]	D[2]	D[1]	D[0]
Must Be Set To Zero			Fault Queue	INT/CMPTR POLARITY	COMP/INT.	Shut-Down	

D0: Shutdown: 0 = Normal Operation  
1 = Shutdown Mode

D1: CMPTR/INT: 0 = Comparator Mode  
1 = Interrupt Mode

D2: INT/CMPTR POLARITY: 0 = Active Low  
1 = Active High

D3 - D4: Fault Queue: Number of sequential temperature-to-digital conversions with the same result before the INT/CMPTR output is updated:

D4	D3	Number of Conversions
0	0	1 (Power-up-default)
0	1	2
1	0	4
1	1	6

## TCN75

## Temperature (TEMP) Register, 16-bits, Read-only

The binary value in this register represents ambient temperature following a conversion cycle.

## Temperature Register (TEMP)

D[15]	D[14]	D[13]	D[12]	D[11]	D[10]	D[9]	D[8]	D[7]	D[6]	D[5]	D[4]	D[3]	D[2]	D[1]	D[0]
MSB	D7	D6	D5	D4	D3	D2	D1	LSB	X	X	X	X	X	X	X

Temperature Setpoint ( $T_{SET}$ ) and Hysteresis ( $T_{HYST}$ ) Register, 16-bits, Read-Write:Temperature Setpoint Register ( $T_{SET}$ )

D[15]	D[14]	D[13]	D[12]	D[11]	D[10]	D[9]	D[8]	D[7]	D[6]	D[5]	D[4]	D[3]	D[2]	D[1]	D[0]
MSB	D7	D6	D5	D4	D3	D2	D1	LSB	X	X	X	X	X	X	X

Hysteresis Register ( $T_{HYST}$ )

D[15]	D[14]	D[13]	D[12]	D[11]	D[10]	D[9]	D[8]	D[7]	D[6]	D[5]	D[4]	D[3]	D[2]	D[1]	D[0]
MSB	D7	D6	D5	D4	D3	D2	D1	LSB	X	X	X	X	X	X	X

In the TEMP,  $T_{SET}$ , and  $T_{HYST}$  registers, each unit value represents one-half degree (Celsius). The value is in 2's - complement binary format such that a reading of 000000000b corresponds to 0°C. Examples of this temperature to binary value relationship are shown in the following table.

## Temperature to Digital Value Conversion

Temperature	Binary Value	HEX Value
+125°C	0 11111010	0FA
+25°C	0 00110010	032
+0.5°C	0 00000001	001
0°C	0 00000000	00
- 0.5°C	1 11111111	1FF
- 25°C	1 11001110	1CE
- 40°C	1 10110000	1B0
- 55°C	1 10010010	192

The TCN75's register set is summarized below

Name	Description	Width	Read	Write	Notes
TEMP	Ambient Temperature	16	X		2's Complement Format
$T_{SET}$	Temperature Setpoint	16	X	X	2's Complement Format
$T_{HYST}$	Temperature Hysteresis	16	X	X	2's Complement Format
POINT	Register Pointer	8	X	X	
CONFIG	Configuration Register	8	X	X	



**PACKAGE DIMENSIONS**

**8-Pin Plastic DIP**

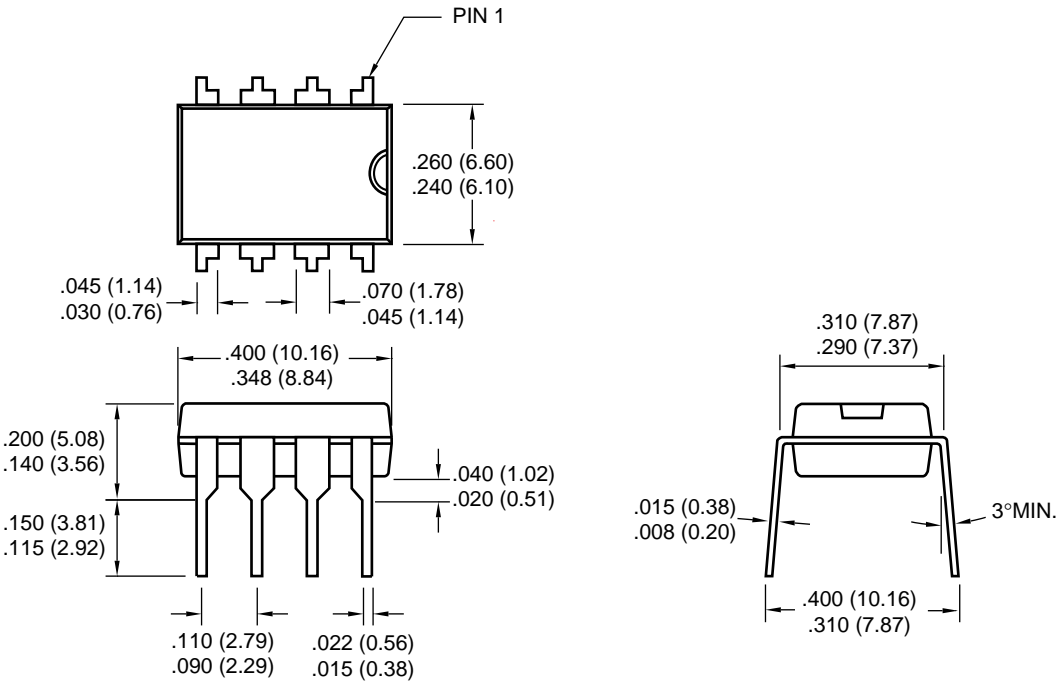

**8-Pin SOIC**

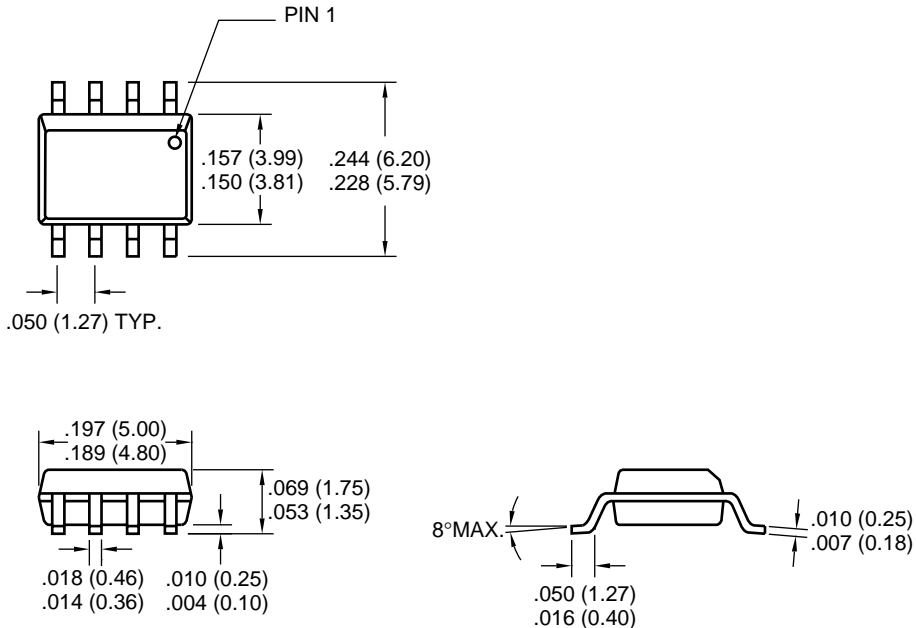

Dimensions: inches (mm)

TCN75

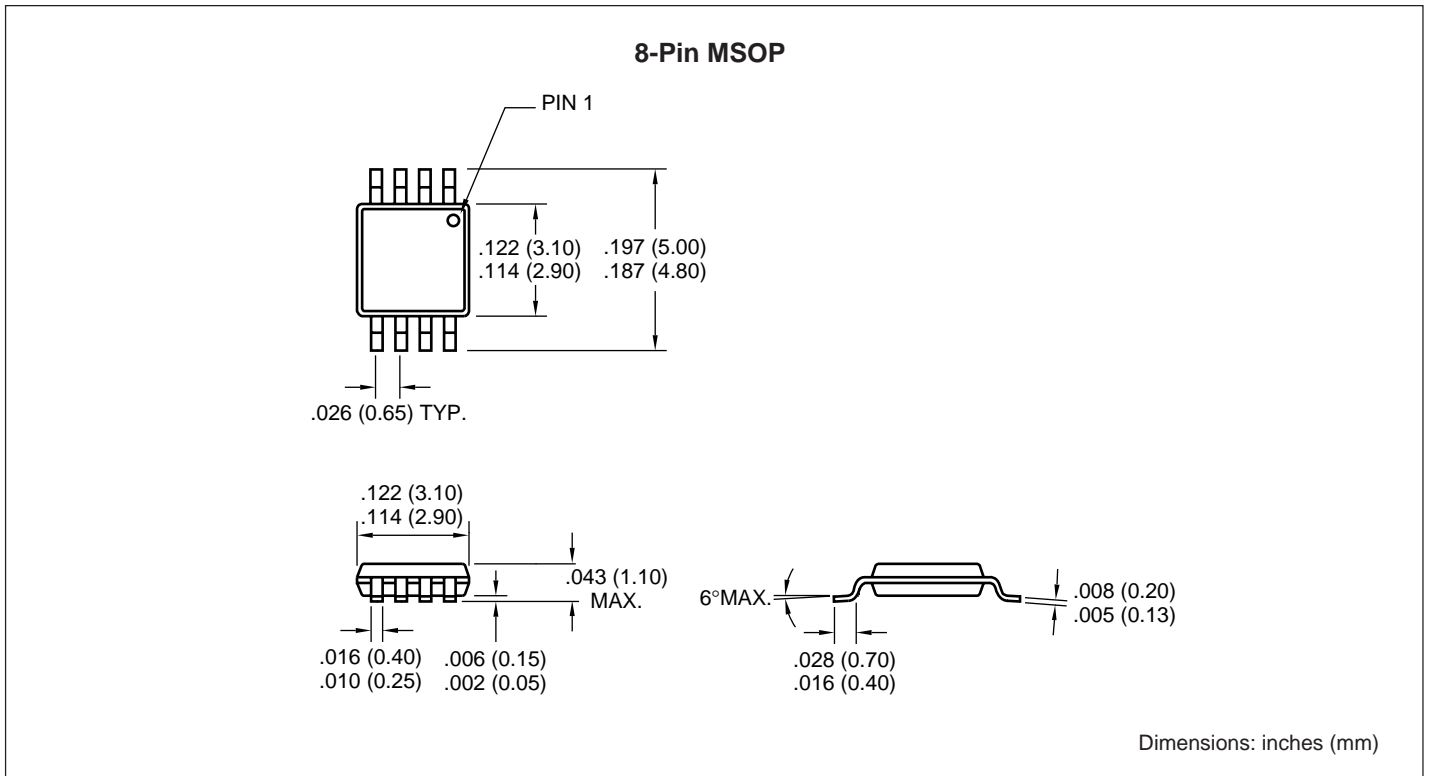

**Sales Offices**

**TelCom Semiconductor**  
 1300 Terra Bella Avenue  
 P.O. Box 7267  
 Mountain View, CA 94039-7267  
 TEL: 415-968-9241  
 FAX: 415-967-1590  
 E-Mail: liter@c2smtp.telcom-semi.com

**TelCom Semiconductor**  
 Austin Product Center  
 9101 Burnet Rd. Suite 214  
 Austin, TX 78758  
 TEL: 512-873-7100  
 FAX: 512-873-8236

**TelCom Semiconductor H.K. Ltd.**  
 10 Sam Chuk Street, Ground Floor  
 San Po Kong, Kowloon  
 Hong Kong  
 TEL: 852-2324-0122  
 FAX: 852-2354-9957