

## ***8-Bit Bidirectional Voltage-Level Translator with Auto Direction sensing and ±15kV ESD Protection***

### **UM3308 CSP20 2.7×2.4**

### **General Description**

UM3308 is 8-channel bidirectional voltage level translator with auto direction sensing and ±15kV ESD protection. This 8-channel noninverting translator uses two separate configurable power-supply rails. The A port is designed to track  $V_{CCA}$ .  $V_{CCA}$  accepts any supply voltage from 1.2V to 3.6V. The B port is designed to track  $V_{CCB}$ .  $V_{CCB}$  accepts any supply voltage from 1.65V to 5.5V. This allows for universal low-voltage bidirectional translation between any of the 1.2V, 1.5V, 1.8V, 2.5V, 3.3V, and 5V voltage nodes. Both I/O ports are auto-sensing; thus, no direction pin is required, making it ideal for data transfer between low-voltage ASICs/PLDs and higher voltage systems.

The UM3308 operates at a guaranteed data rate of 20Mbps over the entire specified operating voltage range. Within specific voltage domains, higher data rates are up to 100Mbps.

When the output-enable (OE) input is low, all outputs are placed in the high-impedance state. The UM3308 is designed so that the OE input circuit is supplied by  $V_{CCA}$ .

To ensure the high-impedance state during power up or power down, OE should be tied to GND through a pull down resistor; the minimum value of the resistor is determined by the current-sourcing capability of the driver.

The UM3308 is 8-channel level translator available in CSP20 2.7×2.4 bump package.

### **Applications**

- Low-Voltage ASIC Level Translation
- Cell-Phone Cradles
- Portable POS Systems
- Portable Communication Devices
- Low-Cost Serial Interfaces
- Cell-Phones
- GPS
- Telecommunications Equipment

### **Features**

- 1.2V to 3.6V on A Port and 1.65V to 5.5V on B Port ( $V_{CCA} \leq V_{CCB}$ )
- $V_{CC}$  Isolation Feature – If Either  $V_{CC}$  Input is at GND, All Outputs are in the High-Impedance State
- OE Input Circuit Referenced to  $V_{CCA}$
- Low Power Consumption
- Latch-Up Performance Exceeds 100mA
- ±15kV ESD Protection on B Ports

### **Pin Configurations**

### **Top View**

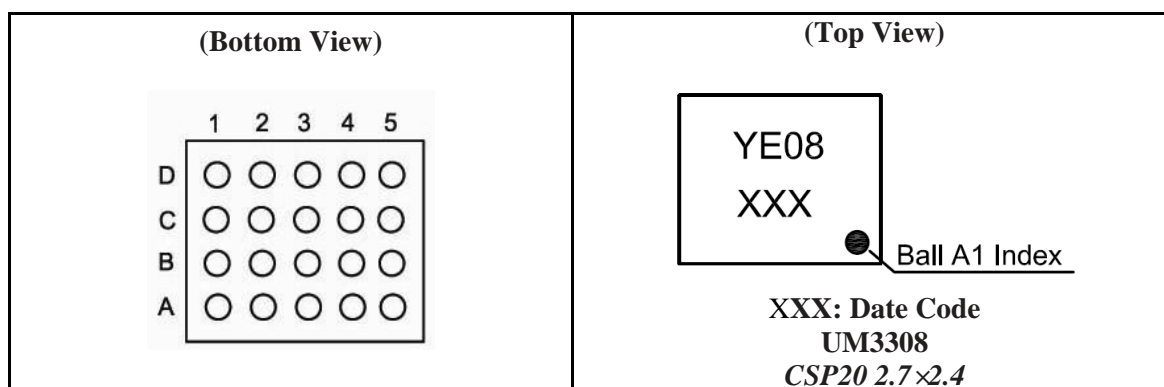

**Terminal Assignments**

	1	2	3	4	5
D	V <sub>CCB</sub>	B2	B4	B6	B8
C	B1	B3	B5	B7	GND
B	A1	A3	A5	A7	OE
A	V <sub>CCA</sub>	A2	A4	A6	A8

**Pin Description**

Pin Name	Function
A1	Input/Output 1. Referenced to V <sub>CCA</sub>
V <sub>CCA</sub>	A-Port supply voltage. $1.1V \leq V_{CCA} \leq 3.6V$ and $V_{CCA} \leq V_{CCB}$
A2	Input/Output 2. Referenced to V <sub>CCA</sub>
A3	Input/Output 3. Referenced to V <sub>CCA</sub>
A4	Input/Output 4. Referenced to V <sub>CCA</sub>
A5	Input/Output 5. Referenced to V <sub>CCA</sub>
A6	Input/Output 6. Referenced to V <sub>CCA</sub>
A7	Input/Output 7. Referenced to V <sub>CCA</sub>
A8	Input/Output 8. Referenced to V <sub>CCA</sub>
OE	3-state output enable. Pull OE low to place all outputs in 3-state mode. Referenced to V <sub>CCA</sub>
GND	Ground
B8	Input/Output 8. Referenced to V <sub>CCB</sub>
B7	Input/Output 7. Referenced to V <sub>CCB</sub>
B6	Input/Output 6. Referenced to V <sub>CCB</sub>
B5	Input/Output 5. Referenced to V <sub>CCB</sub>
B4	Input/Output 4. Referenced to V <sub>CCB</sub>
B3	Input/Output 3. Referenced to V <sub>CCB</sub>
B2	Input/Output 2. Referenced to V <sub>CCB</sub>
V <sub>CCB</sub>	B-Port supply voltage. $1.65V \leq V_{CCB} \leq 5.5V$
B1	Input/Output 1. Referenced to V <sub>CCB</sub>

**Ordering Information**

Part Number	Packaging Type	Marking Code	Shipping Qty
UM3308	CSP20 2.7×2.4	YE08	2500pcs/7Inch Tape & Reel

**Absolute Maximum Ratings (Note 1)**

Over operating free-air temperature range (unless otherwise noted)

Symbol	Parameter	Value	Unit
$V_{CCA}$	Supply Voltage Range	-0.5 to +4.5	V
$V_{CCB}$	Supply Voltage Range	-0.5 to +6.5	V
$V_I$	Input Voltage Range (Note 2)	A ports	-0.5 to +4.5
		B ports	-0.5 to +6.5
$V_O$	Voltage Range applied to any output in the high-impedance or power-off state (Note 2)	A ports	-0.5 to +4.5
		B ports	-0.5 to +6.5
$V_O$	Voltage Range applied to any output in the high or low state (Note 2,3)	A ports	-0.5 to ( $V_{CCA}+0.5$ )
		B ports	-0.5 to ( $V_{CCB}+0.5$ )
$I_{IK}$	Input Clamp Current	$V_I < 0$	-50
$I_{OK}$	Output Clamp Current	$V_O < 0$	-50
$I_O$	Continuous Output Current		$\pm 50$
	Continuous Current through $V_{CCA}$ , $V_{CCB}$ , or GND		$\pm 100$
$\theta_{JA}$	Package Thermal Impedance	78	$^{\circ}\text{C}/\text{W}$
$T_{OP}$	Operating Temperature Range	-40 to +85	$^{\circ}\text{C}$
$T_{STG}$	Storage Temperature Range	-65 to +150	$^{\circ}\text{C}$

Note 1: Stresses beyond those listed under "absolute maximum ratings" may cause permanent damage to the device. These are stress ratings only, and functional operation of the device at these or any other conditions beyond those indicated under "recommended operating conditions" is not implied. Exposure to absolute-maximum-rated conditions for extended periods may affect device reliability.

Note 2: The input and output negative-voltage ratings may be exceeded if the input and output current ratings are observed.

Note 3: The value of  $V_{CCA}$  and  $V_{CCB}$  are provided in the recommended operating conditions table.

**Recommended Operating Conditions (Note 1, 2)**

Symbol	Parameter	$V_{CCA}$	$V_{CCB}$	Min	Max	Unit
$V_{CCA}$	Supply Voltage			1.2	3.6	V
				1.65	5.5	V
$V_{IH}$	High Level Input Voltage	Data Inputs	1.2V to 3.6V	1.65V to 5.5V	$V_{CCI} \times 0.65$ (Note3)	$V_{CCI}$
		OE	1.2V to 3.6V	1.65V to 5.5V	$V_{CCA} \times 0.65$	5.5
$V_{IL}$	Low Level Input Voltage	Data Inputs	1.2V to 5.5V	1.65V to 5.5V	0	$V_{CCI} \times 0.35$
		OE	1.2V to 3.6V	1.65V to 5.5V	0	$V_{CCA} \times 0.35$
$\Delta t/\Delta V$	Input Transition Rise or Fall Time	A-Port Inputs	1.2V to 3.6V	1.65V to 5.5V		40
		B-Port Inputs	1.2V to 3.6V	1.65V to 3.6V		40
				4.5V to 5.5V		30

Note 1: The A and B sides of an unused data I/O pair must be held in the same state, i.e., both at  $V_{CCI}$  or both at GND.

Note 2:  $V_{CCA}$  must be less than or equal to  $V_{CCB}$  and must not exceed 3.6 V.

Note 3:  $V_{CCI}$  is the supply voltage associated with the input port.

**Electrical Characteristics (Note 1, 2)**

Over recommended operating free-air temperature range (unless otherwise noted)

Parameter	Test Conditions	V <sub>CCA</sub>	V <sub>CCB</sub>	T <sub>A</sub> =25°C		-40°C to 85°C		Unit
				Typ	Max	Min	Max	
V <sub>OHA</sub>	I <sub>OH</sub> =-20μA	1.2V		1.1		V <sub>CCA</sub> -0.4		V
		1.4V to 3.6V						
V <sub>OLA</sub>	I <sub>OL</sub> =20μA	1.2V		0.9				V
		1.4V to 3.6V				0.4		
V <sub>OHB</sub>	I <sub>OH</sub> =-20μA		1.65V to 5.5V			V <sub>CCB</sub> -0.4		V
V <sub>OLB</sub>	I <sub>OL</sub> =20μA		1.65V to 5.5V				0.4	V
I <sub>I</sub>	OE	1.2V to 3.6V	1.65V to 5.5V		±1		±2	μA
I <sub>off</sub>	A Port	0V	0V to 5.5V		±1		±2	μA
	B Port	0V to 3.6V	0V		±1		±2	
I <sub>OZ</sub>	A or B Port	OE=GND	1.2V to 3.6V	1.65V to 5.5V			±1	±2
I <sub>CCA</sub>	V <sub>I</sub> =V <sub>CCI</sub> or GND I <sub>O</sub> =0	1.2V	1.65V to 5.5V	0.06				μA
		1.4V to 3.6V	1.65V to 5.5V				5	
		3.6V	0V				2	
		0V	5.5V				-2	
I <sub>CCB</sub>	V <sub>I</sub> =V <sub>CCB</sub> or GND I <sub>O</sub> =0	1.2V	1.65V to 5.5V	3.4				μA
		1.4V to 3.6V	1.65V to 5.5V				5	
		3.6V	0V				-2	
		0V	5.5V				2	
I <sub>CCA</sub> + I <sub>CCB</sub>	V <sub>I</sub> =V <sub>CCI</sub> or GND I <sub>O</sub> =0	1.2V	1.65V to 5.5V	3.5				μA
		1.4V to 3.6V	1.65V to 5.5V				10	
I <sub>CCZA</sub>	V <sub>I</sub> =V <sub>CCI</sub> or GND I <sub>O</sub> =0, OE=GND	1.2V	1.65V to 5.5V	0.05				μA
		1.4V to 3.6V	1.65V to 5.5V				5	
I <sub>CCZB</sub>	V <sub>I</sub> =V <sub>CCB</sub> or GND I <sub>O</sub> =0, OE=GND	1.2V	1.65V to 5.5V	3.3				μA
		1.4V to 3.6V	1.65V to 5.5V				5	
C <sub>i</sub>	OE	1.2V to 3.6V	1.65V to 5.5V	5			5.5	pF
C <sub>io</sub>	A Port	1.2V to 3.6V	1.65V to 5.5V	5			6.5	pF
	B Port			8			10	

 Note 1: V<sub>CCI</sub> is the supply voltage associated with the input port.

 Note 2: V<sub>CCO</sub> is the supply voltage associated with the output port.

**Switching Characteristics**
 $T_A = +25\text{ }^\circ\text{C}$ ,  $V_{CCA} = 1.2\text{V}$ 

Parameter	From (Input)	To (Output)	$V_{CCB}=1.8\text{V}$	$V_{CCB}=2.5\text{V}$	$V_{CCB}=3.3\text{V}$	$V_{CCB}=5\text{V}$	Unit
			Typ	Typ	Typ	Typ	
$t_{pd}$	A	B	7	6	5.3	5.5	ns
	B	A	7.5	6.5	6	6	
$t_{en}$	OE	A	1	1	1	1	$\mu\text{s}$
		B	1	1	1	1	
$t_{dis}$	OE	A	18	16	14	14	ns
		B	19	17	15	15	
$t_{rA}, t_{fA}$	A port rise and fall time		5	5	5	5	ns
$t_{rB}, t_{fB}$	B port rise and fall time		2.5	1.5	1.2	1	ns
$t_{SK(O)}$	Channel-to-channel		0.5	0.5	0.5	1.5	ns
Max data rate			20	20	20	20	Mbps

**Switching Characteristics**

 Over recommended operating free-air temperature range,  $V_{CCA} = 1.5\text{V} \pm 0.1\text{V}$  (unless otherwise noted)

Parameter	From (Input)	To (Output)	$V_{CCB}=1.8\text{V} \pm 0.15\text{V}$		$V_{CCB}=2.5\text{V} \pm 0.2\text{V}$		$V_{CCB}=3.3\text{V} \pm 0.3\text{V}$		$V_{CCB}=5\text{V} \pm 0.5\text{V}$		Unit
			Min	Max	Min	Max	Min	Max	Min	Max	
$t_{pd}$	A	B	2	15	1.2	11	1.1	10	1	10	ns
	B	A	1	15	0.9	12	0.5	12	0.3	13	
$t_{en}$	OE	A		1		1		1		1	$\mu\text{s}$
		B		1		1		1		1	
$t_{dis}$	OE	A	6	30	5.5	28	5.5	25	5.5	23	ns
		B	5.5	30	5	25	5	20	5	20	
$t_{rA}, t_{fA}$	A port rise and fall time		1.5	5.0	1.5	5.0	1.5	5.0	1.5	5.0	ns
$t_{rB}, t_{fB}$	B port rise and fall time		0.9	4.5	0.6	3.5	0.5	3	0.4	2.5	ns
$t_{SK(O)}$	Channel-to-channel			0.5		0.5		0.5		0.5	ns
Max data rate			40		40		40		40		Mbps

**Switching Characteristics**

Over recommended operating free-air temperature range,  $V_{CCA}=1.8V\pm 0.15V$  (unless otherwise noted)

Parameter	From (Input)	To (Output)	$V_{CCB}=1.8V\pm 0.15V$		$V_{CCB}=2.5V\pm 0.2V$		$V_{CCB}=3.3V\pm 0.3V$		$V_{CCB}=5V\pm 0.5V$		Unit
			Min	Max	Min	Max	Min	Max	Min	Max	
$t_{pd}$	A	B	1.6	10	1.4	9	1.3	7	1.2	6.5	ns
	B	A	1.5	12	1.3	8.5	1	8	0.9	8	
$t_{en}$	OE	A		1		1		1		1	$\mu s$
		B		1		1		1		1	
$t_{dis}$	OE	A	6	34	5.5	23	5	20	5	17.6	ns
		B	5.5	33	4.5	22	4.2	16.8	4.4	16.3	
$t_{rA}, t_{fA}$	A port rise and fall time		1	4.2	1.1	4.0	1.1	4.0	1.1	4.0	ns
$t_{rB}, t_{fB}$	B port rise and fall time		0.9	4	0.6	3.2	0.5	2.8	0.4	2.8	ns
$t_{SK(O)}$	Channel-to-channel			0.5		0.5		0.5		0.5	ns
Max data rate			60		60		60		60		Mbps

**Switching Characteristics**

Over recommended operating free-air temperature range,  $V_{CCA}=2.5V\pm 0.2V$  (unless otherwise noted)

Parameter	From (Input)	To (Output)	$V_{CCB}=2.5V\pm 0.2V$		$V_{CCB}=3.3V\pm 0.3V$		$V_{CCB}=5V\pm 0.5V$		Unit
			Min	Max	Min	Max	Min	Max	
$t_{pd}$	A	B	1.1	6.5	1	5.2	0.9	5	ns
	B	A	1.2	6.6	1.1	5.1	0.9	4.4	
$t_{en}$	OE	A		1		1		1	$\mu s$
		B		1		1		1	
$t_{dis}$	OE	A	5.0	23	4.6	15.2	4.6	13	ns
		B	4.4	22	3.8	16	3.9	13.3	
$t_{rA}, t_{fA}$	A port rise and fall time		0.8	3	0.8	3	0.8	3	ns
$t_{rB}, t_{fB}$	B port rise and fall time		0.7	2.7	0.5	2.8	0.4	2.7	ns
$t_{SK(O)}$	Channel-to-channel			0.5		0.5		0.5	ns
Max data rate			100		100		100		Mbps

**Switching Characteristics**

Over recommended operating free-air temperature range,  $V_{CCA}=3.3V \pm 0.3V$  (unless otherwise noted)

Parameter	From (Input)	To (Output)	$V_{CCB}=3.3V \pm 0.3V$		$V_{CCB}=5V \pm 0.5V$		Unit
			Min	Max	Min	Max	
$t_{pd}$	A	B	0.9	5	0.8	4	ns
	B	A	1	5.1	0.9	4	
$t_{en}$	OE	A		1		1	$\mu s$
		B		1		1	
$t_{dis}$	OE	A	5	15	4	13	ns
		B	4	16	3.4	13.8	
$t_{rA}, t_{fA}$	A port rise and fall time		0.7	2.5	0.7	2.5	ns
$t_{rB}, t_{fB}$	B port rise and fall time		0.5	2.1	0.4	2.8	ns
$t_{SK(O)}$	Channel-to-channel			0.5		0.5	ns
Max data rate			100		100		Mbps

**Operating Characteristics**

$T_A=+25^\circ C$

Parameter		Test Conditions	$V_{CCB}$						Unit	
			5V	1.8V	1.8V	1.8V	2.5V	5V		3.3V to 5V
			$V_{CCA}$							
			1.2V Typ	1.2V Typ	1.5V Typ	1.8V Typ	2.5V Typ	2.5V Typ		3.3V Typ
$C_{pdA}$	A-port input B-port output	$C_L=0,$ $f=10MHz,$ $t_r=t_f=1ns,$ $OE=V_{CCA}$	9	10	10	10	10	10	10	pF
	B-port input A-port output		12	11	11	11	11	11	11	
$C_{pdB}$	A-port input B-port output		35	28	28	29	3.0	30	30	
	B-port input A-port output		27	19	19	19	20	21	23	
$C_{pdA}$	A-port input B-port output	$C_L=0,$ $f=10MHz,$ $t_r=t_f=1ns,$ $OE=GND$	0.01	0.01	0.01	0.01	0.01	0.01	0.01	pF
	B-port input A-port output		0.01	0.01	0.01	0.01	0.01	0.01	0.01	
$C_{pdB}$	A-port input B-port output		0.01	0.01	0.01	0.01	0.01	0.01	0.03	
	B-port input A-port output		0.01	0.01	0.01	0.01	0.01	0.01	0.05	

## Applications Information

UM3308 ESD protected level translator provides level shifting necessary to allow data transfer in a multi-voltage system. Externally applied voltages,  $V_{CCA}$  and  $V_{CCB}$  set the logic levels on either side of device. A low voltage signal present on  $V_{CCA}$  side of the device appears as a high voltage logic signal on the  $V_{CCB}$  side of the device, and vice-versa.

## Block Diagram

The UM3308 (block diagram see Figure 1) does not require a direction-control signal to control the direction of data flow from A to B or from B to A. In a dc state, the output drivers of the UM3308 can maintain a high or low, but are designed to be weak, so that they can be overdriven by an external driver when data on the bus starts flowing to the opposite direction.

The output one shot detects rising or falling edges on the A or B ports. During a rising edge, the one shot turns on the PMOS transistors (T1, T3) for a short duration, which speeds up the low-to-high transition. Similarly, during a falling edge, the one shot turns on the NMOS transistors (T2, T4) for a short duration, which speeds up the high-to-low transition.

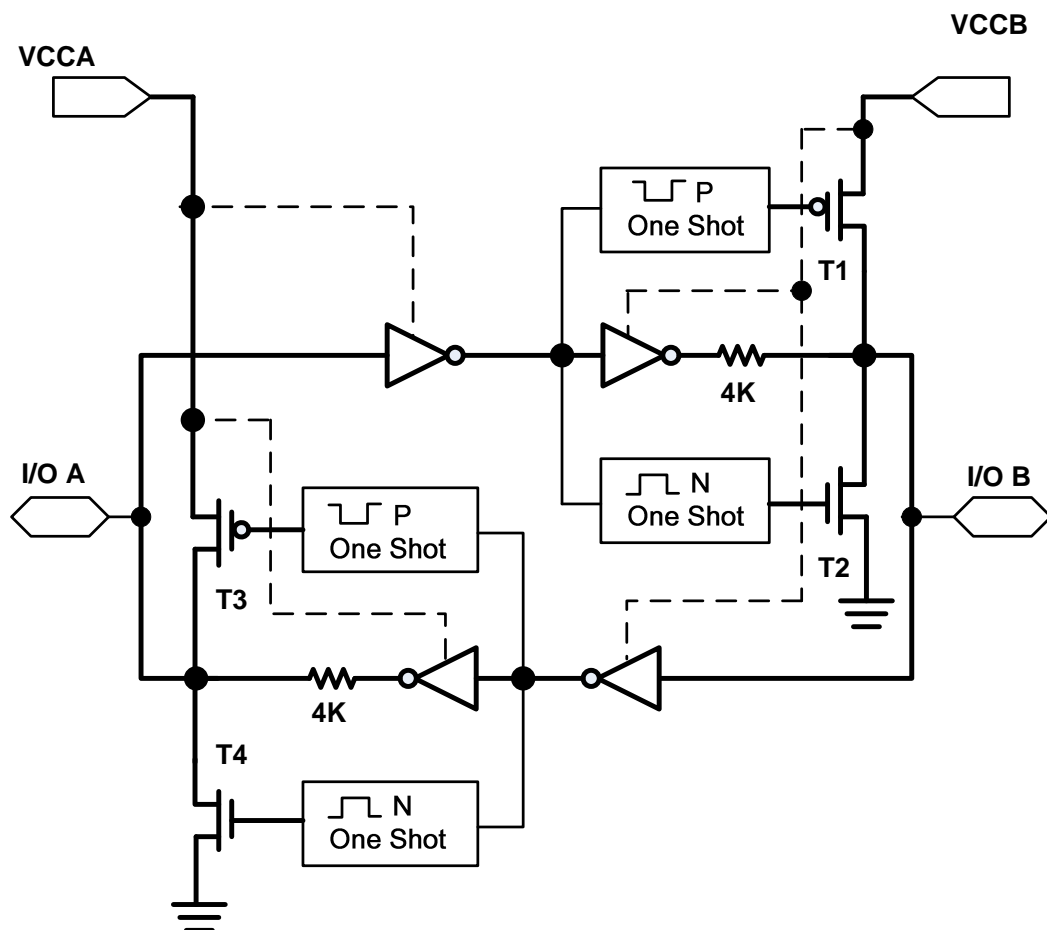
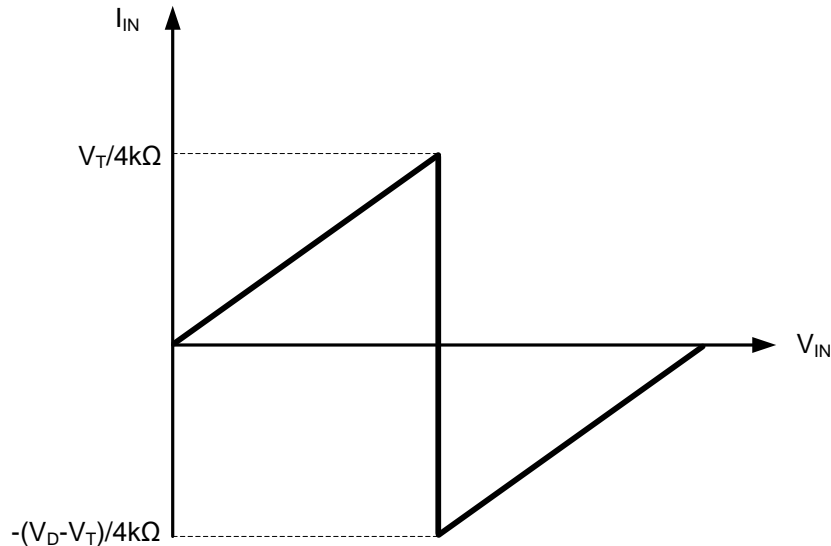

Figure 1 Block Diagram of UM3308 I/O Cell



## Input Driver Requirements

Typical  $I_{IN}$  vs  $V_{IN}$  characteristics of the UM3308 are shown in Figure 2. For proper operation, the device driving the data I/Os of the UM3308 must have drive strength of at least  $\pm 2$  mA.



- A:  $V_T$  is the input threshold voltage of the UM3308 (typical  $V_{CCI}/2$ )
- B:  $V_D$  is the supply voltage of the external driver.

**Figure 2 Typical  $I_{IN}$  vs  $V_{IN}$  Curve**

## Power Up

During operation, ensure that  $V_{CCA} \leq V_{CCB}$  at all times. During power-up sequencing,  $V_{CCA} \geq V_{CCB}$  does not damage the device, so any power supply can be ramped up first. The UM3308 has circuitry that disables all output ports when either  $V_{CC}$  is switched off ( $V_{CCA/B} = 0$  V).

## Enable and Disable

The UM3308 has an OE input that is used to disable the device by setting OE = low, which places all I/Os in the high-impedance (Hi-Z) state. The disable time ( $t_{dis}$ ) indicates the delay between when OE goes low and when the outputs actually get disabled (Hi-Z). The enable time ( $t_{en}$ ) indicates the amount of time the user must allow for the one-shot circuitry to become operational after OE is taken high.

## Pullup or Pulldown Resistors on I/O Lines

The UM3308 is designed to drive capacitive loads of up to 50pF. The output drivers of the UM3308 have low dc drive strength. If pullup or pulldown resistors are connected externally to the data I/Os, their values must be kept higher than 50 k $\Omega$  to ensure that they do not contend with the output drivers of the UM3308.

For the same reason, the UM3308 should not be used in applications such as I<sup>2</sup>C or 1-Wire where an open-drain driver is connected on the bidirectional data I/O.

## Typical Operating Circuit

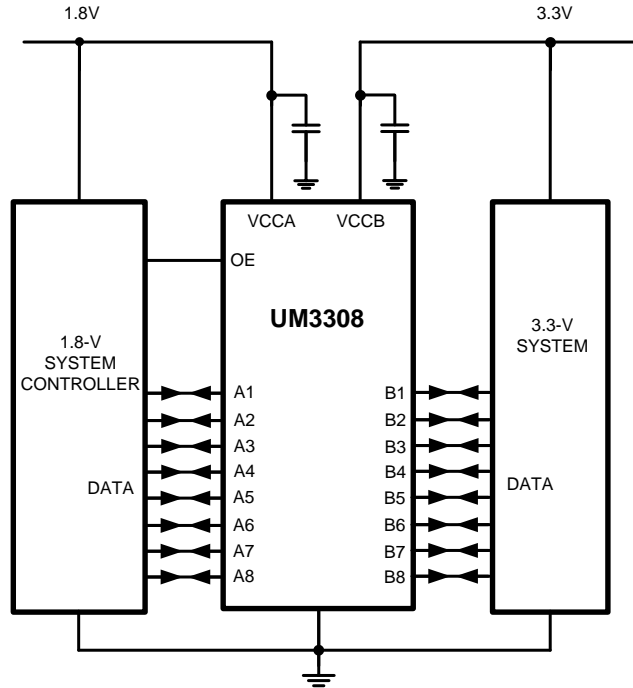
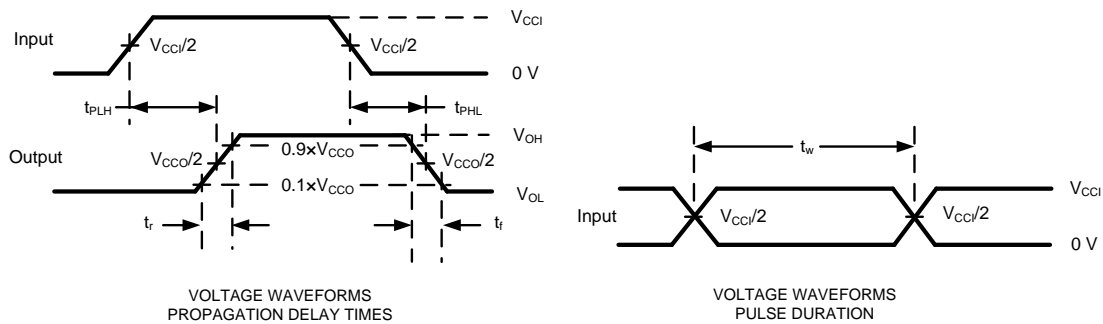
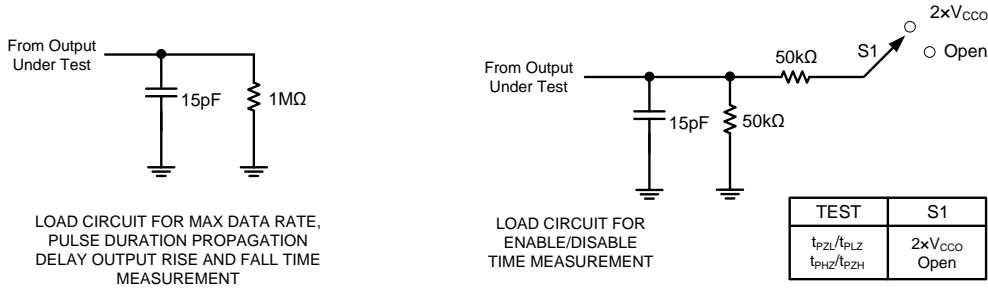

Figure 3 Typical operating circuit

## Test Circuits



- A.  $C_i$  includes probe and jig capacitance.
- B. All input pulses are supplied by generators having the following characteristics:  $PRR \leq 10\text{MHz}$ ,  $Z_o = 50\Omega$ ,  $dv/dt \geq 1\text{V/ns}$ .
- C. The outputs are measured one at a time, with one transition per measurement.
- D.  $t_{PLH}$  and  $t_{PHL}$  are the same as  $t_{pd}$ .
- E.  $V_{CCI}$  is the  $V_{CC}$  associated with the input port.
- F.  $V_{CCO}$  is the  $V_{CC}$  associated with the output port.
- G. All parameters and waveforms are not applicable to all devices.

Figure 4 Load Circuits and Voltage Waveforms

## Package Information

### UM3308: CSP20 2.7×2.4

#### Outline Drawing

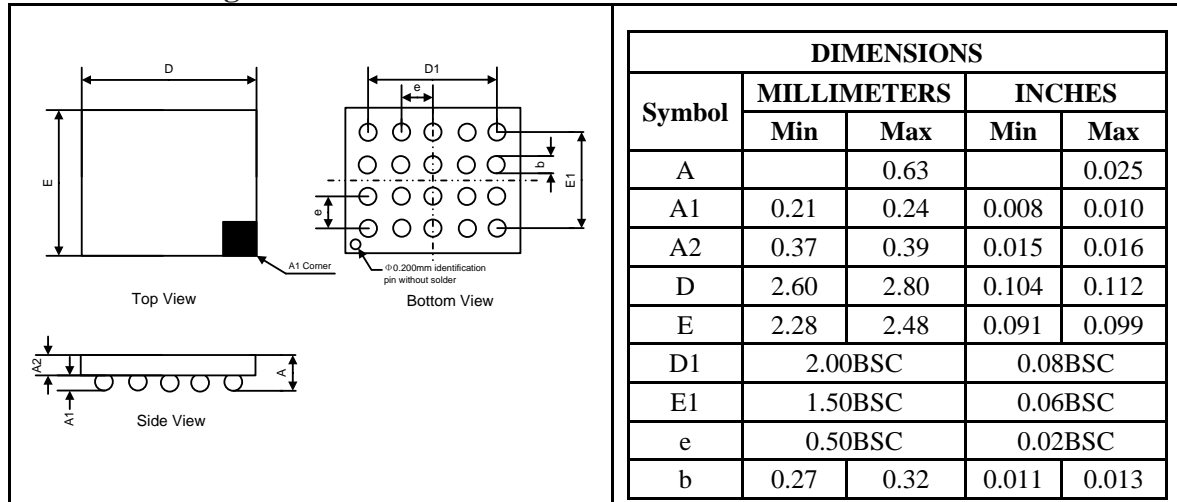

#### Land Pattern

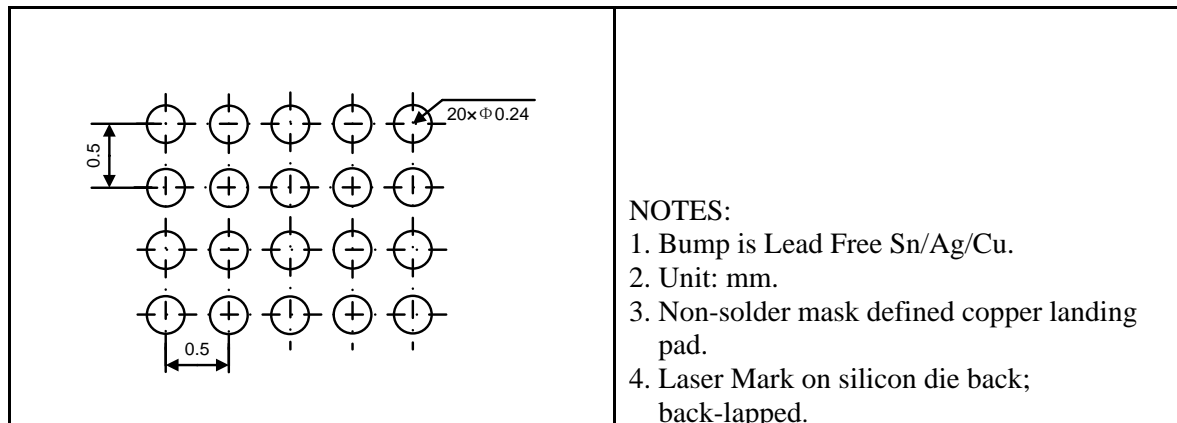

#### Tape and Reel Orientation

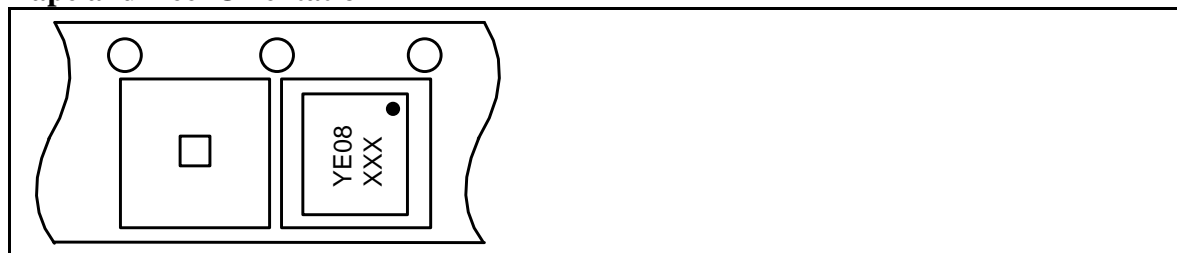

---

**IMPORTANT NOTICE**

The information in this document has been carefully reviewed and is believed to be accurate. Nonetheless, this document is subject to change without notice. Union assumes no responsibility for any inaccuracies that may be contained in this document, and makes no commitment to update or to keep current the contained information, or to notify a person or organization of any update. Union reserves the right to make changes, at any time, in order to improve reliability, function or design and to attempt to supply the best product possible.



Union Semiconductor, Inc

Add: 2F, No. 3, Lane 647 Songtao Road, Shanghai 201203

Tel: 021-51093966

Fax: 021-51026018

Website: [www.union-ic.com](http://www.union-ic.com)