

FEATURES

- HIGH FREQUENCY OPERATION TO 2.5 GHz
- WIDE BAND OPERATION
- SINGLE SUPPLY VOLTAGE: $V_{CC} = 5\text{ V} \pm 10\%$
- AVAILABLE IN TAPE AND REEL (G08 PACKAGE)

DESCRIPTION

The UPB584 series of devices are divide-by-2 silicon bipolar prescalers. They feature high frequency response and operate from a single 5 volt supply. The series is available in two package styles: 8 lead ceramic flat pack (UPB584B) and an 8 pin plastic mini-flat package (UPB584G). Applications include: synthesizer for DBS receiver and other telecommunication applications.

RECOMMENDED OPERATING CONDITIONS

SYMBOL	PARAMETER	UNITS	RATINGS
VCC	Supply Voltage	V	4.5 to 5.5
TOP	Operating Temperature	°C	-20 to +75

TEST CIRCUIT

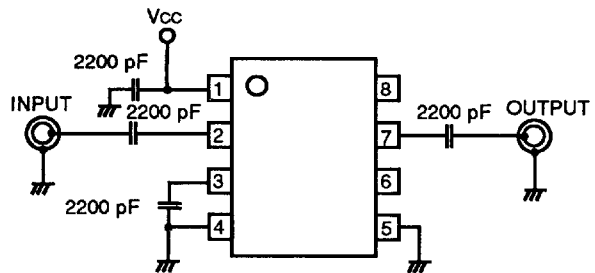

Note: Because of the high internal gain and gain compression of the UPB584, this device is prone to self-oscillation in the absence of an RF input signal. If the device will be used in an application where DC power will be applied in the absence of an RF input signal, this self-oscillation can be suppressed by any of the following means:

- * Add a shunt resistor from the RF input line to ground. The blocking capacitor should be between the resistor and the UPB584, but physical separation should be minimized. Typically a resistor value between 50 and 100 ohms will suppress the self-oscillation.
- * Apply a DC offset voltage of +3.0 volts to the INPUT pin. The voltage source should be isolated from the INPUT pin by a series 1000 ohm resistor.
- * Apply a DC offset voltage of +1.5 volts to the BYPASS pin. The voltage source should be isolated from the BYPASS pin by a series 1000 ohm resistor.

All these approaches reduce the input sensitivity of the UPB584 (by as much as 3 dB for the example of a 50 ohm shunt resistor), but otherwise have no effect on the reliability or other electrical characteristics of this device.

5

ELECTRICAL CHARACTERISTICS¹ ($T_A = -20$ to $+75^\circ\text{C}$, $V_{CC} = 5\text{ V}$)

PART NUMBER PACKAGE OUTLINE			UPB584B, UPB584G BF08, G08		
SYMBOLS	PARAMETERS AND CONDITIONS	UNITS	MIN	TYP	MAX
I _{CC}	Supply Current, $T_A = 25^\circ\text{C}$	mA	12	18	24
f _{IN}	Frequency Response at: P _{IN} = -15 to +5 dBm P _{IN} = -10 to +5 dBm	GHz GHz	0.5 0.5		2.3 2.5
P _{IN}	Input Power at f _{IN} = 0.5 to 2.3 GHz f _{IN} = 0.5 to 2.5 GHz	dBm dBm	-15 -10		+5 +5
P _{OUT}	Power Output at f _{IN} = 2 GHz, P _{IN} = 0 dBm, V _{CC} = 5 V, $T_A = 25^\circ\text{C}$	dBm	-12	-7	
R _{TH (J-C)}	Thermal Resistance, Junction to Case (UPB584B)	°C/W			50
R _{TH (J-A)}	Thermal Resistance, Junction to Ambient (UPB584G) ²	°C/W			270

Notes:

1. $V_{CC} = 5\text{ V} \pm 10\%$ (unless otherwise noted) $Z_S = Z_O = 50\ \Omega$.
2. Mounted on a 5 x 5 x 0.16 mm epoxy glass circuit board.

UPB584B, UPB584G

ABSOLUTE MAXIMUM RATINGS¹ (TA = 25°C)

SYMBOLS	PARAMETERS	UNITS	RATINGS
V _{CC}	Supply Voltage	V	-0.5 to 6.0
V _{IN}	Input Voltage	V	-0.5 to V _{CC} + 0.5
P _{IN}	Input Power	dBm	+10
P _D	Power Dissipation UPB584B UPB584G	W	1.5 (TA = +125°C)
		mW	250 (TA = +85°C)
T _{OP}	Operating Temperature UPB584B UPB584G	°C	-55 to +125
		°C	-40 to +85
T _{STG}	Storage Temperature UPB584B UPB584G	°C	-55 to +200
		°C	-65 to +150

Note:

1. Operation in excess of any one of these parameters may result in permanent damage.

INTERNAL BLOCK DIAGRAM

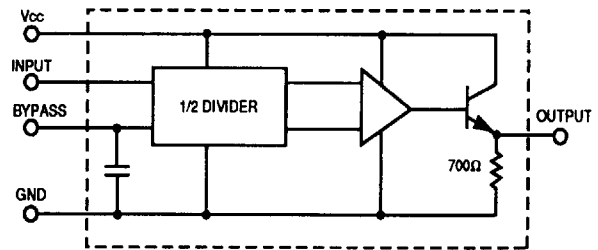

TYPICAL PERFORMANCE CURVES (TA = 25°C unless otherwise noted)

CIRCUIT CURRENT vs. VOLTAGE

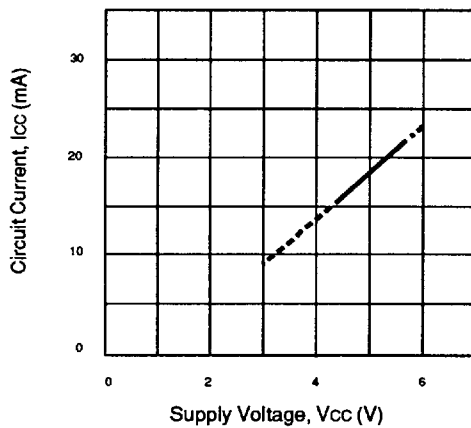

INPUT POWER vs. FREQUENCY AND VOLTAGE

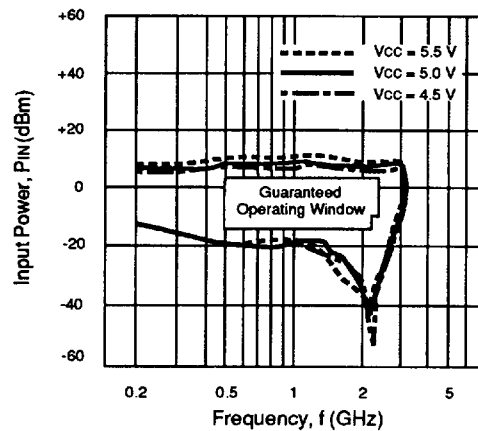

INPUT POWER vs. FREQUENCY AND TEMPERATURE

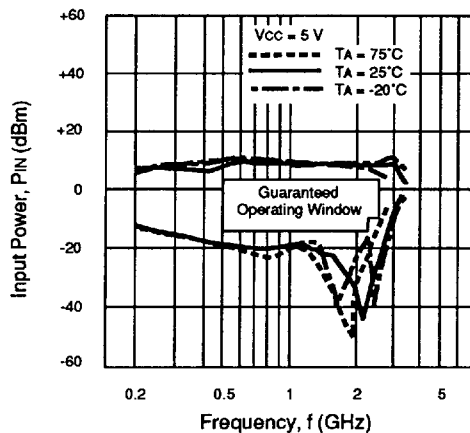

UPB584G SSB PHASE NOISE vs. OFFSET FROM CARRIER
f_{IN} = 1 GHz, TA = 25°C

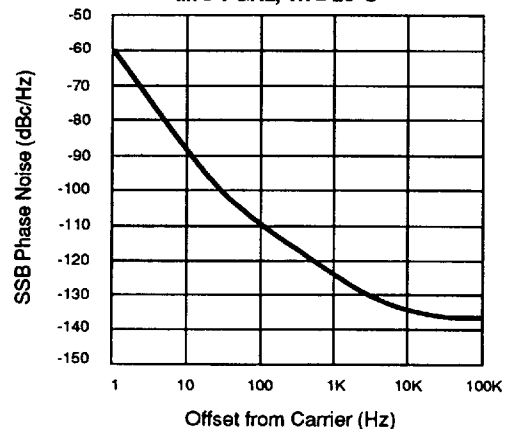

TYPICAL PERFORMANCE CURVES

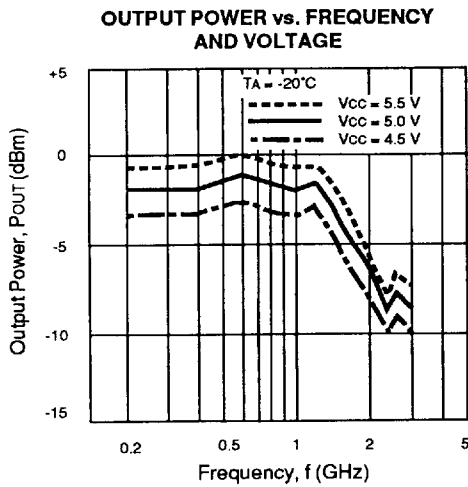
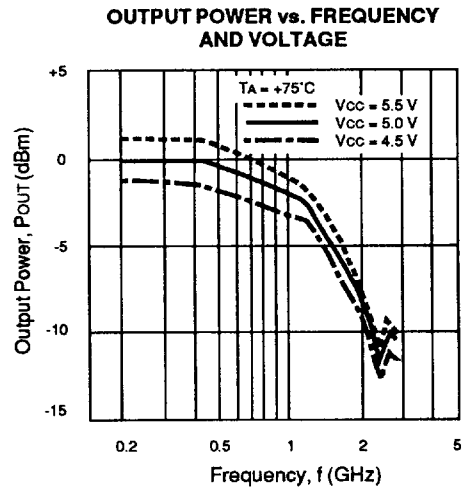
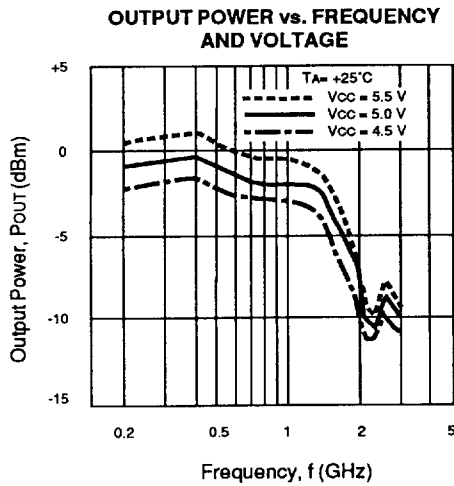

UPB584G
INPUT AND OUTPUT S-PARAMETERS

VCC = 5 V, ICC = 18 mA

Frequency		S11		Frequency		S22	
(GHz)	MAG	ANG	(GHz)	MAG	ANG	(GHz)	ANG
0.20	0.076	-154	0.10	0.424	173		
0.40	0.095	-149	0.20	0.550	149		
0.60	0.117	-148	0.30	0.566	130		
0.80	0.138	-150	0.40	0.580	112		
1.00	0.159	-150	0.50	0.593	95		
1.20	0.185	-154	0.60	0.605	79		
1.40	0.210	-159	0.70	0.613	65		
1.60	0.234	-164	0.80	0.619	51		
1.80	0.258	-170	0.90	0.620	38		
2.00	0.284	-176	1.00	0.619	27		
2.20	0.309	177	1.10	0.614	16		
2.40	0.334	170	1.20	0.607	6		
2.60	0.361	162	1.30	0.599	-5		
2.80	0.385	154	1.40	0.588	-14		
3.00	0.407	145	1.50	0.575	-23		

5

EQUIVALENT CIRCUIT

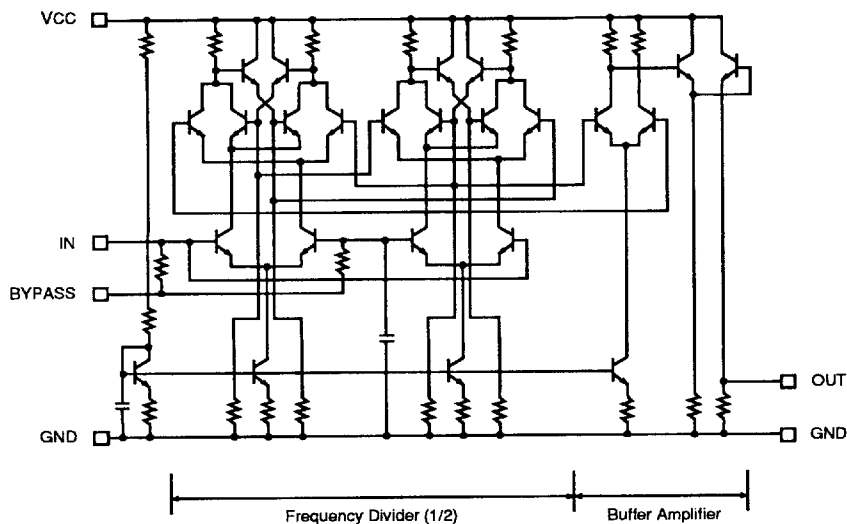

UPB584B, UPB584G

OUTLINE DIMENSIONS (Units in mm)

**UPB584B
PACKAGE OUTLINE BF08**

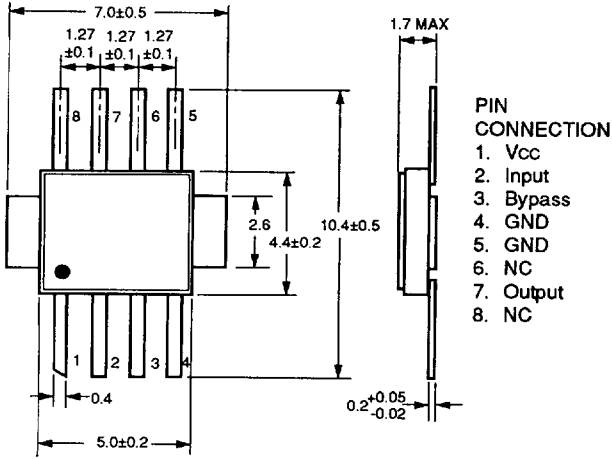

**UPB584G
PACKAGE OUTLINE G08**

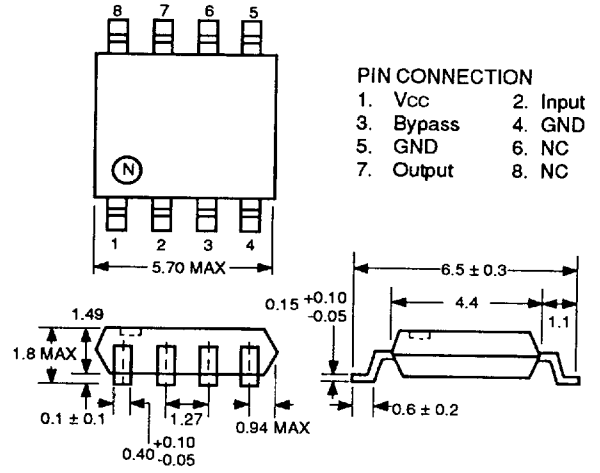

ORDERING INFORMATION

PART NUMBER	QTY
UPB584G-E1	2500/Reel