

Feature

- Full diffusion process
- Capsule type ceramic package
- Double side cooling

Typical Application

- High power transmission
- Welding equipment
- Motor control and drive
- Battery charger

$I_{F(AV)}$	300A
V_{RRM}	100-5000V
I_{FSM}	4.2 KA
I^2t	90 $10^3 a^2s$

SYMBOL	CHARACTERISTIC	TEST CONDITIONS	T_J (°C)	VALUE		UNIT
				Min	Max	
$I_{F(AV)}$	Mean forward current	180° half sine wave 50Hz Double side cooled, THS=97°C	125		300	A
V_{RRM}	Repetitive peak reverse voltage	$V_{DRM} \& V_{RRM} t_p = 10ms$ $V_{DSM} \& V_{RSM} = V_{DRM} \& V_{RRM} + 100V$	125	100	5000	V
I_{RRM}	Repetitive peak current	$V_{RM} = V_{RRM}$	125		30	mA
I_{FSM}	Surge on-state current	10ms half sine wave	125		4.2	KA
I^2t	I^2t for fusing coordination	$V_R = 0.6V_{RRM}$			90	$A^2S * 10$
V_{FO}	Threshold voltage		125		0.98	V
r_T	On-state slop resistance				0.31	mΩ
V_{FM}	Peak on-state voltage	$I_{TM} = 900A, F = 15KN$	25		1.8	V
I_{RM}	Reverse recovery current	$I_{TM} = 900A, t_q = 1000us$ $Di/dt = -20A/us.$ $V_r = 50V$	125		75	A
t_{rr}	Reverse recovery time				4.0	us
Q_{rr}	Recovery charge				159.7	uC
$R_{th(j-h)}$	Thermal resistance Junction to heat sink	At 180° sine double side cooled Clamping force 5.0kn			0.065	°C/W
F_M	Mounting force			3.5	10	KN
T_{stq}	Stored temperature			-40	160	°C
W_t	Weight					g
Outline						

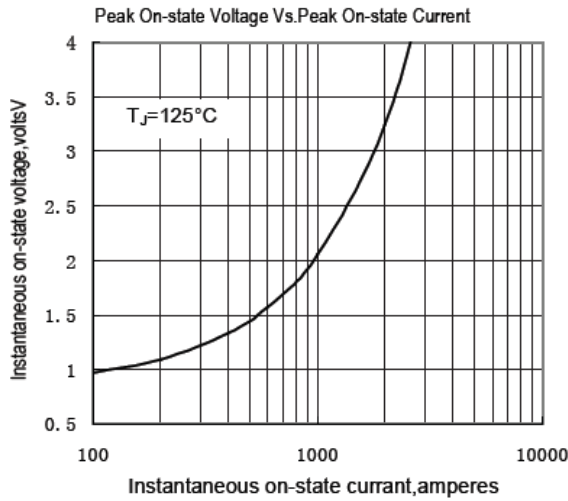

Fig.1

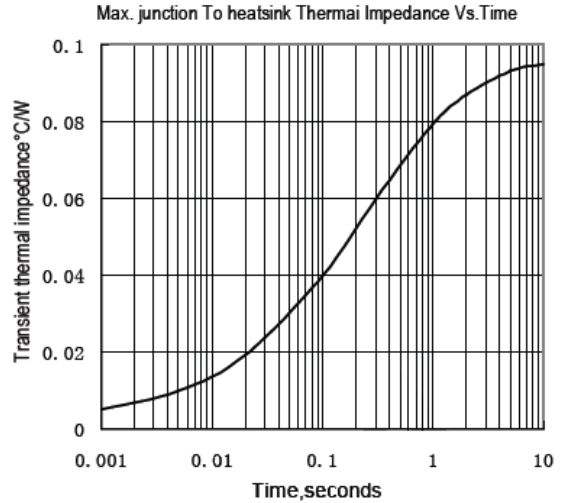

Fig.2

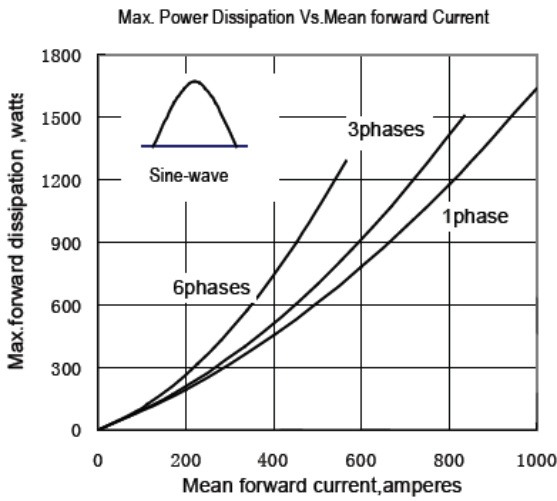

Fig.3

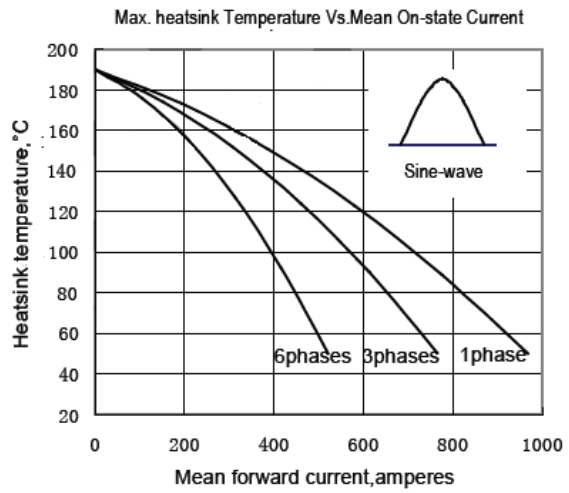

Fig.4

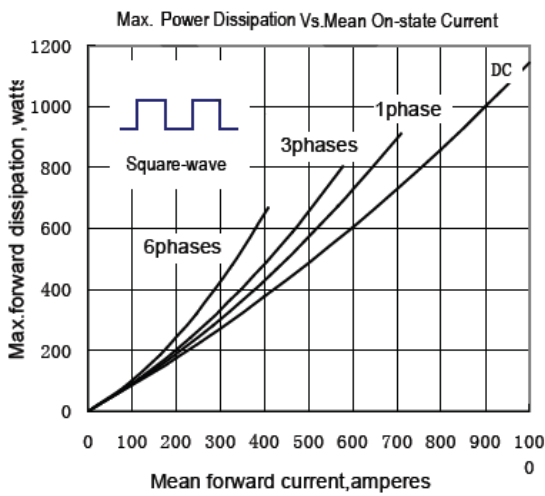

Fig.5

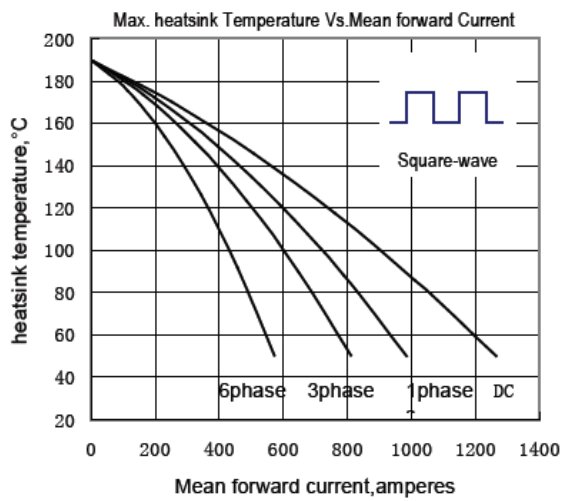

Fig.6

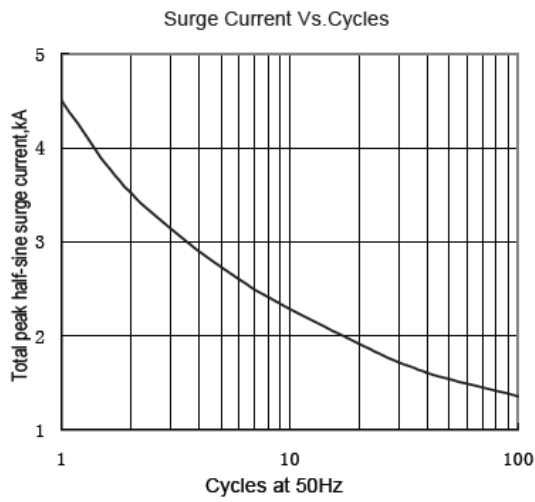

Fig.7

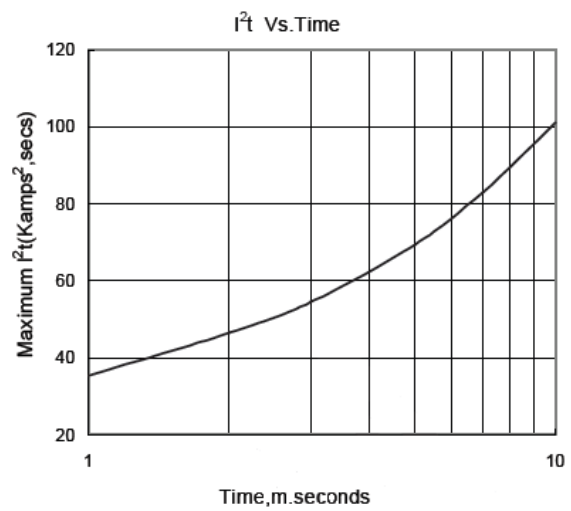
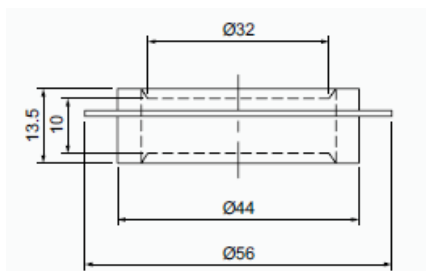
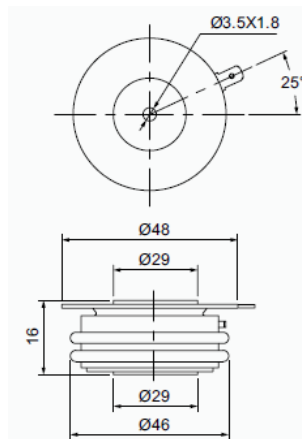

Fig.8

Outline:



1



2

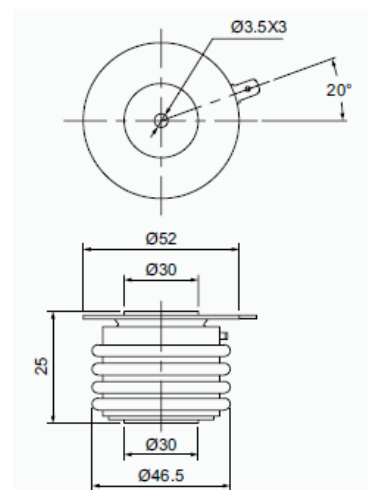

3