



# 1N5391~1N5399

## PLASTIC SILICON RECTIFIER

**VOLTAGE** 50 to 1000 Volts **CURRENT** 1.5 Amperes

**DO-15** Unit: inch(mm)

### FEATURES

- Plastic package has Underwriters Laboratories Flammability Classification 94V-O utilizing Flame Retardant Epoxy Molding Compound.
- Exceeds environmental standards of MIL-S-19500/228
- Low leakage.
- In compliance with EU RoHS 2002/95/EC directives

### MECHANICAL DATA

- Case: Molded plastic, DO-15
- Terminals: Axial leads, solderable to MIL-STD-750, Method 2026
- Polarity: Color Band denotes cathode end
- Mounting Position: Any
- Weight: 0.014 ounce, 0.397 gram

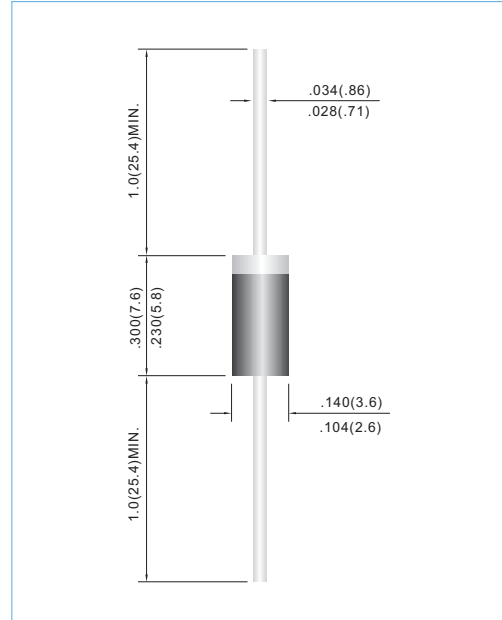

## MAXIMUM RATINGS AND ELECTRICAL CHARACTERISTICS

Ratings at 25°C ambient temperature unless otherwise specified. Resistive or inductive load, 60Hz, Single phase, half wave, For capacitive load, derate current by 20%

PARAMETER	SYMBOL	1N5391	1N5392	1N5393	1N5394	1N5395	1N5396	1N5397	1N5398	1N5399	UNITS
Maximum Recurrent Peak Reverse Voltage	$V_{RRM}$	50	100	200	300	400	500	600	800	1000	V
Maximum RMS Voltage	$V_{RMS}$	35	70	140	210	280	350	420	560	700	V
Maximum DC Blocking Voltage	$V_{DC}$	50	100	200	300	400	500	600	800	1000	V
Maximum Average Forward Current .375" (9.5mm) lead length at $T_A=60^\circ\text{C}$	$I_{F(AV)}$	1.5									A
Peak Forward Surge Current :8.3ms single half sine-wave superimposed on rated load(JEDEC method)	$I_{FSM}$	50									A
Maximum Forward Voltage at 1.5A	$V_F$	1.4									V
Maximum DC Reverse Current $T_j=25^\circ\text{C}$ at Rated DC Blocking Voltage $T_j=100^\circ\text{C}$	$I_R$	5.0 500									$\mu\text{A}$
Typical Junction capacitance (Note 1)	$C_j$	25									pF
Typical Thermal Resistance(Note 2)	$R_{\theta JA}$ $R_{\theta JL}$	45 28									$^\circ\text{C} / \text{W}$
Operating Junction and Storage Temperature Range	$T_j, T_{STG}$	-55 to +150									$^\circ\text{C}$

NOTES: 1. Measured at 1 MHz and applied reverse voltage of 4.0 VDC

2. Thermal resistance from junction to ambient and from junction to lead length 0.375" (9.5mm) P.C.B. mounted



# 1N5391~1N5399

## RATING AND CHARACTERISTIC CURVES

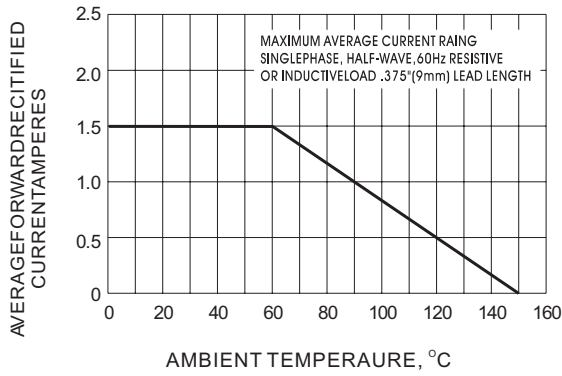

Fig.1- FORWARD CURRENT DERATING CURVE

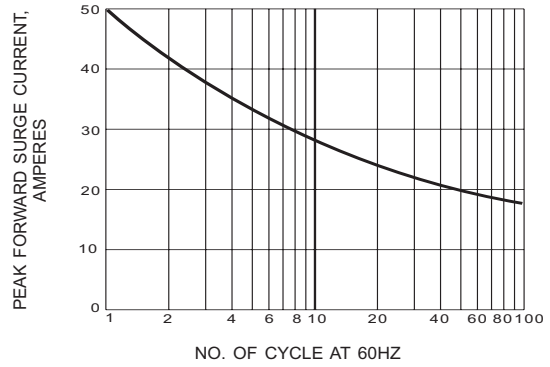

Fig.2- MAXIMUM OVERLOAD SURGE CURRENT

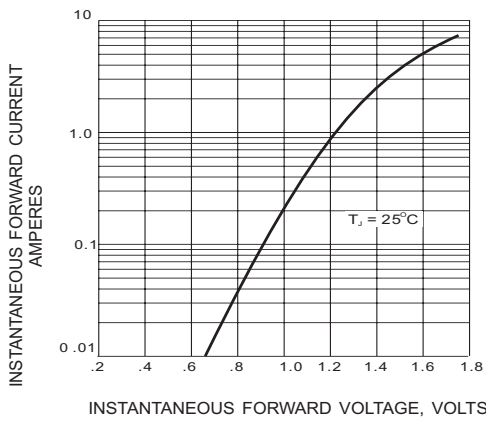

Fig.3- TYPICAL FORWARD CHARACTERISTIC

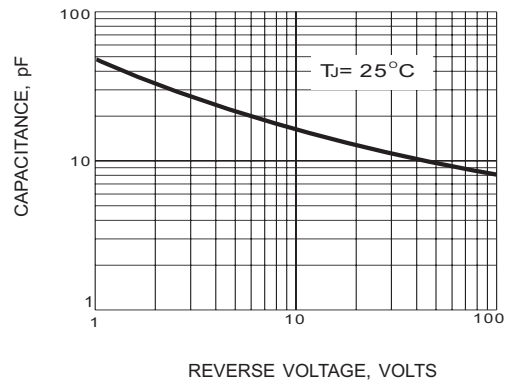

Fig.4- TYPICAL JUNCTION CAPACITANCE

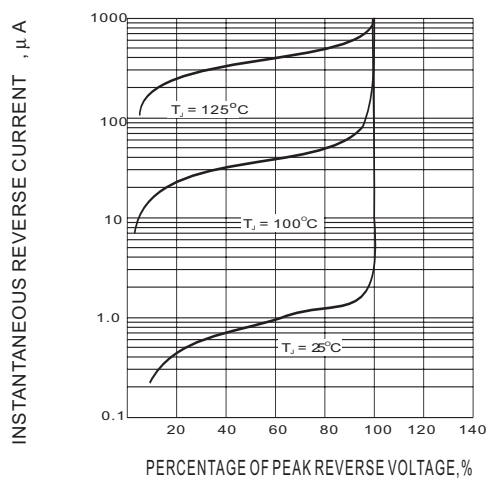

Fig.5- TYPICAL REVERSE CHARACTERISTIC