

LED Drivers for LED Backlights

Backlight LED Driver for Small LCD Panels (Charge Pump Type)



BD1606MVV

No.11040EAT24

●Description

The multi-level brightness control white LED driver not only ensures efficient boost by automatically changing the boost rate but also works as a constant current driver in 64 steps, so that the driving current can be adjusted finely. This IC is best suited to turn on white LEDs that require high-accuracy LED brightness control.

●Features

- 1) A 6 parallel LED driver is mounted
- 2) 64-step LED current adjust function
- 3) Inter-LED relative current accuracy: 3% or less
- 4) LED individual lighting/dimming control via a I²C BUS interface
- 5) Automatic transition charge pump type DC/DC converter (×1, ×1.5 and ×2)
- 6) High efficiency achieved (90% or more at maximum)
- 7) Various protection functions such as output voltage protection, overcurrent limiter and thermal shutdown circuit are mounted.
- 8) Small QFN package

●Applications

This driver is applicable for various fields such as mobile phones, portable game machines and white goods.

●Absolute Maximum Rating (Ta=25°C)

Parameter	Symbol	Limits	Unit
Power supply voltage	VMAX	7	V
Operating temperature range	Topr	-30 ~ +85	°C
Storage temperature range	Tstg	-55 ~ +150	°C
Power dissipation	Pd	780 (*1)	mW

(*1) When a glass epoxy substrate (70mm × 70mm × 1.6mm) has been mounted, this loss will decrease 6.2mW/°C if Ta is higher than or equal to 25°C.

●Recommended Operation Range (Ta=-30°C to +85°C)

Parameter	Symbol	Limits	Unit
Operating power supply voltage	VCC	2.7~5.5	V

● **Electrical Characteristics** (Unless otherwise stated, Ta is 25°C and Vin is 3.6V)

Parameter	Symbol	Limits			Unit	Condition
		Min.	Typ.	Max.		
Input voltage range	V _{in}	2.7	3.6	5.5	V	V _{in} pin
Quiescent current	I _q	-	0	7	μA	EN=0V, V _{in} =3.6V
Circuit current 1	I _{DD1}	-	1.0	2.6	mA	×1 mode, I _{out} =0mA, V _{in} =3.6V
[Charge pump]						
Output current	I _{OUT}	-	-	120	mA	V _{OUT} =4.0V, V _{in} =3.6V
Oscillation frequency	f _{OSC}	0.8	1.0	1.2	MHz	Add=0x03, D6='0'
[LED driver]						
LED current absolute precision	I _{LED-ERR}	-	-	±6.5	%	I _{LED} =16.5mA(LEDxCNT=0x20), LED pin voltage 1.0 V
LED current relative precision	I _{LED-to-LED}	-	0.5	±3.75* ¹⁾	%	I _{LED} =16.5mA(LEDxCNT=0x20), LED pin voltage 1.0V
LED control voltage	V _{LED}	-	0.2	0.25	V	I _{LEDA} */B*/C*
[Logic interface]						
Input 'L' voltage	V _{IL}	-	-	0.4	V	EN, SCL, SDA
Input 'H' voltage	V _{IH}	1.6	-	-	V	EN, SCL, SDA
Input 'H' current	I _{IH}	-	-	10	μA	EN, SCL, SDA=V _{in}
Input 'L' current	I _{IL}	-10	-	-	μA	EN, SCL, SDA=GND
'L' level SDA output	V _{OL}	-	-	0.4	V	SDA, 3mA source
		-	-	0.6	V	SDA, 6mA source
[I ² C BUS interface (standard mode)]						
SCL clock frequency	f _{SCLC}	0	-	100	kHz	
SCL Low duration	t _{LOW}	4.7	-	-	μs	
SCL High duration	t _{HIGH}	4.0	-	-	μs	
Data hold time	t _{HD} ;DAT	0	-	3.45	μs	
Data setup time	t _{SU} ;DAT	250	-	-	ns	
Setup time – restart condition	t _{SU} ;STA	4.7	-	-	μs	
Hold time – restart condition	t _{HD} ;STA	4.0	-	-	μs	
Setup time – stop condition	t _{SU} ;STO	4.0	-	-	μs	
Bus free time between start and stop	t _{BUF}	4.7	-	-	μs	
[I ² C BUS interface (fast mode)]						
SCL clock frequency	f _{SCL}	0	-	400	kHz	
SCL Low duration	t _{LOW}	1.3	-	-	μs	
SCL High duration	t _{HIGH}	0.6	-	-	μs	
Data hold time	t _{HD} ;DAT	0	-	0.9	μs	
Data setup time	t _{SU} ;DAT	100	-	-	ns	
Setup time – restart condition	t _{SU} ;STA	0.6	-	-	μs	
Hold time – restart condition	t _{HD} ;STA	0.6	-	-	μs	
Setup time – stop condition	t _{SU} ;STO	0.6	-	-	μs	
Bus free time between start and stop	t _{BUF}	1.3	-	-	μs	
Interface startup time	T _{EN}	-	-	350	μs	Bus startup time (after En='H')

*1) The following expression is used for calculation:

$$I_{LED-match} = \frac{(I_{max} - I_{min})}{(I_{max} + I_{min})} \times 100$$

I_{max}= Current value in a channel with the maximum current value among all channels

I_{min}=Current value in a channel with the minimum current value among all channels

●Reference Data

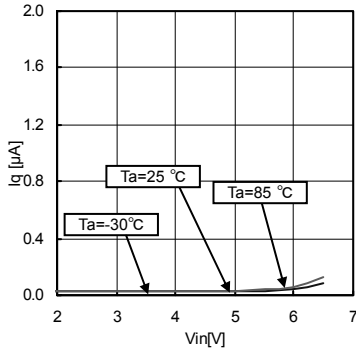

Fig.1 Circuit Current (Standby)

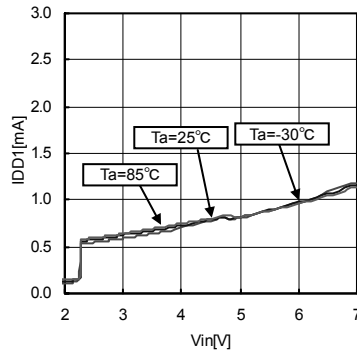

Fig.2 Circuit Current (Operation in $\times 1.0$ Mode)

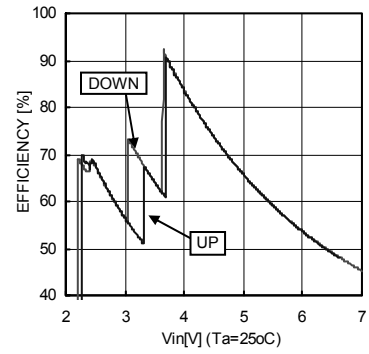

Fig.3 Efficiency Hysteresis (13mA \times 6 Lights)

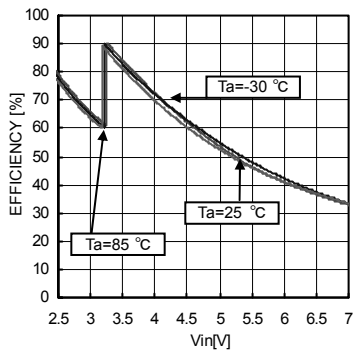

Fig.4 Efficiency (3.5mA \times 6 Lights)

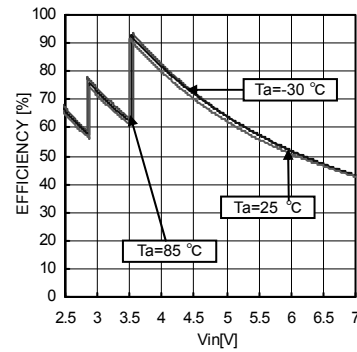

Fig.5 Efficiency (10mA \times 6 Lights)

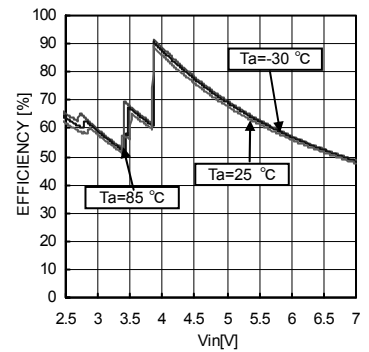

Fig.6 Efficiency (20mA \times 6 Lights)

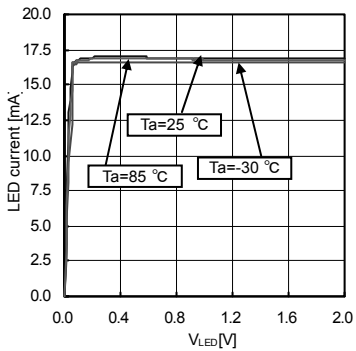

Fig.7 LED Current Characteristics (LED current 16.5mA)

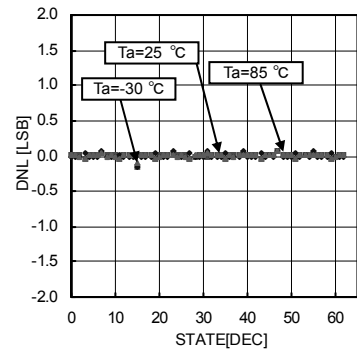

Fig.8 LED Current Characteristics (Differential Linearity Error)

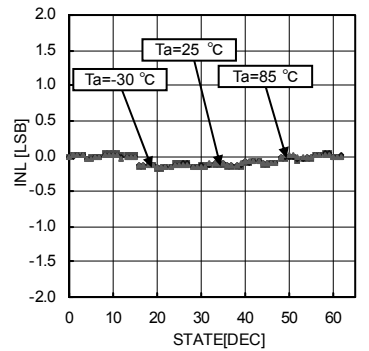

Fig.9 LED Current Characteristics (Integral Linearity Error)

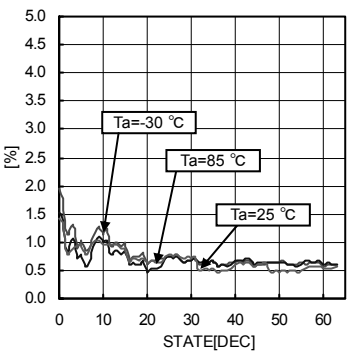

Fig.10 LED Current matching

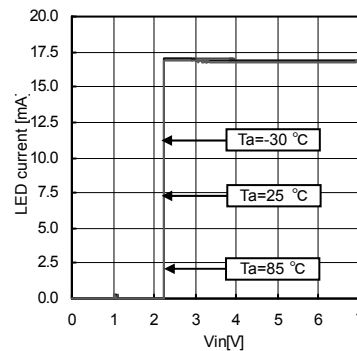

Fig.11 LED Current vs. V_{in} (LED current 16.5mA)

●Block Diagram and Recommended Circuit Example

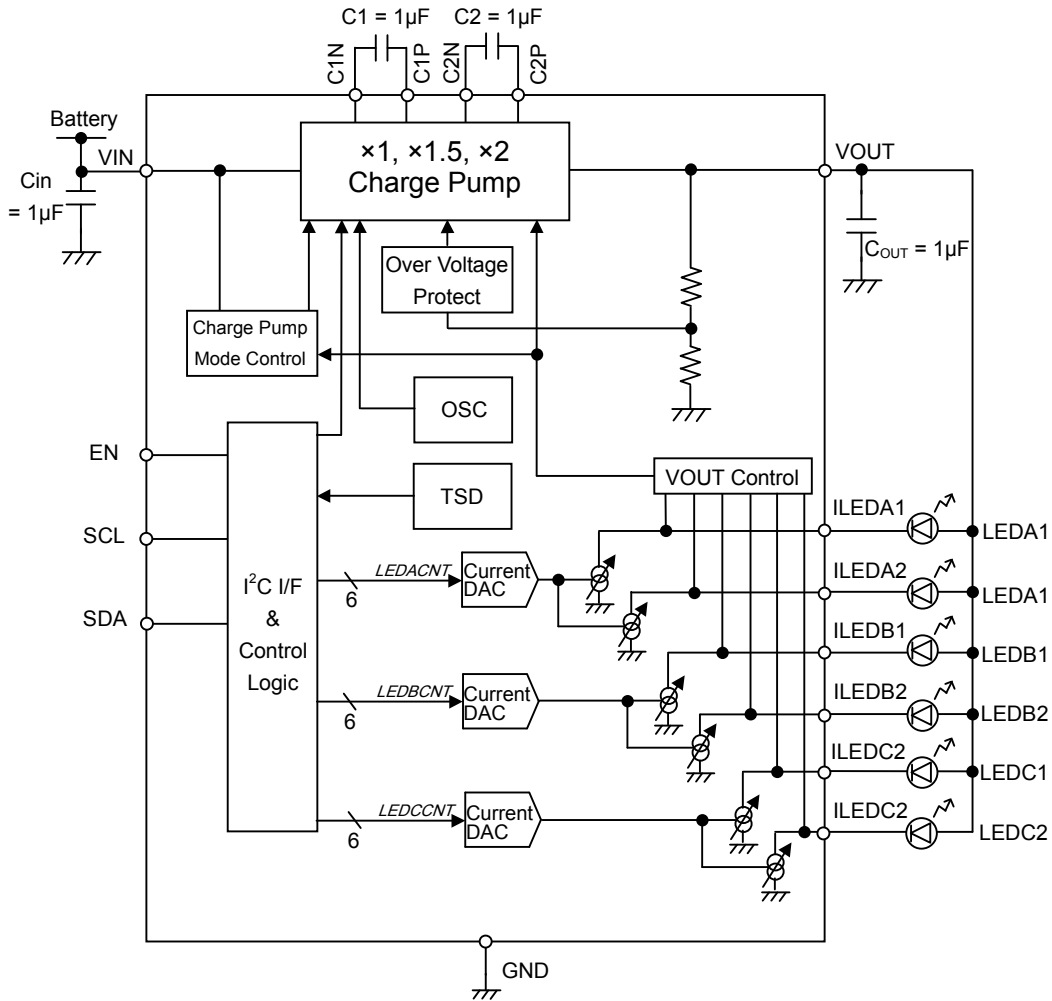

Fig.12 Block Diagram and Recommended Circuit Example

●Pin Table

Pin number	Pin name	In/Out	Function	Pin number	Pin name	In/Out	Function
1	LEDA1	Out	LED current driver output	9	C2N	In/Out	Flying capacitor pin negative (-) side
2	SDA	In	I ² C BUS control pin	10	C2P	In/Out	Flying capacitor pin positive (+) side
3	SCL	In	I ² C BUS control pin	11	GND	-	GND
4	EN	In	ON/OFF control	12	LEDC2	Out	LED current driver output
5	VOUT	Out	Charge pump output	13	LEDC1	Out	LED current driver output
6	VIN	-	Power supply	14	LEDB2	Out	LED current driver output
7	C1N	In/Out	Flying capacitor pin negative (-) side	15	LEDB1	Out	LED current driver output
8	C1P	In/Out	Flying capacitor pin positive (+) side	16	LEDA2	Out	LED current driver output

●Description of Operations

- (1) LED driver
 - I²C BUS interface

BD1606MVV can control the LED ON/OFF, brightness and charge pump switching frequency change by writing to the register via the I²C BUS interface. Control by the I²C BUS interface is effective when EN is at 'H' level. When EN is at 'L' level, this LSI is completely shut down and control and associated functions via the I²C BUS interface are all stopped. As shown in Fig.13 below, the I²C BUS interface of BD1606MVV operates using the Ven voltage (buffering the EN pin voltage) as supply voltage. For this reason, it is desirable that the 'H' voltage in the I²C BUS interface is equal to the EN pin voltage.

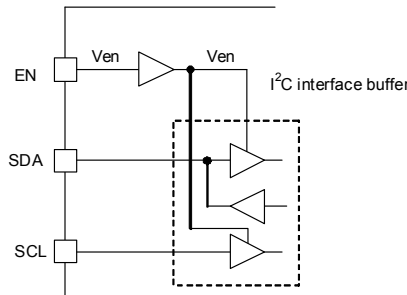

Fig.13 I²C BUS Interface Buffer

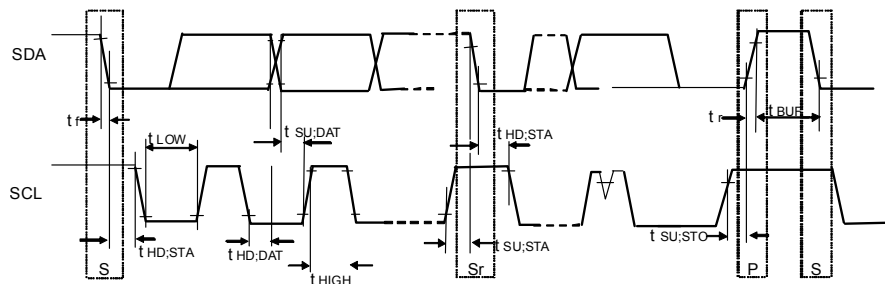

Fig.14 I²C BUS Interface Timing

BD1606MVV operates as a slave device for the I²C BUS interface.

a) Slave address

A7	A6	A5	A4	A3	A2	A1	R/W
1	1	0	0	1	1	0	1/0

b) Data format

The data format is shown below.

Write format:

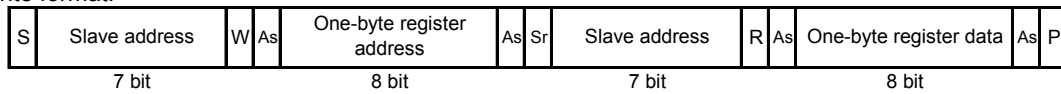

Or

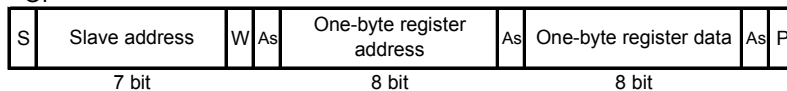

Read format:

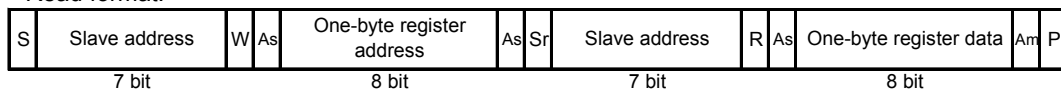

- Note)
- S: Start condition
 - W: '0'=Write
 - R: '1'=Read
 - As: Acknowledge (slave -> master)
 - Am: No acknowledge
 - Sr: Repeated start condition
 - P: Stop condition

• Register table

a) Register map

Address Hex	Register name	D7	D6	D5	D4	D3	D2	D1	D0	Function
0x00	LEDACNT	-	-	LEDACNT						Current setting of ILEDA1/2
0x01	LEDBCNT	-	-	LEDBCNT						Current setting of ILEDA1/2
0x02	LEDCCNT	-	-	LEDCCNT						Current setting of ILEDA1/2
0x03	LEDPWRCNT	-	FREQNT 1/0	LEDC2	LEDC1	LEDB2	LEDB1	LEDA2	LEDA1	Current driver ON/OFF control

Note) 'L': Invalid at write time
'L': 'L' at read time

b) Description of registers

* LEDACNT (initial value: undefined) --- <Address: 0x00, Data: [D5:D0]>

* LEDBCNT (initial value: undefined) --- <Address: 0x01, Data: [D5: D0]>

* LEDCCNT (initial value: undefined) --- <Address: 0x02, Data: [D5: D0]>

LED current values are controlled. LEDA1/A2, LEDB1/B2 and LEDC1/C2 are controlled via the registers LEDACNT, LEDBCNT and LEDCCNT respectively, and the current setting can be switched every 2 channels.

For the current setting value in each register setting, refer to 'LED Current Setting Table' on page 11.

* LEDA1 (initial value: '0') --- <Address: 0x03, Data: D0>

* LEDA2 (initial value: '0') --- <Address: 0x03, Data: D1>

* LEDB1 (initial value: '0') --- <Address: 0x03, Data: D2>

* LEDB2 (initial value: '0') --- <Address: 0x03, Data: D3>

* LEDC1 (initial value: '0') --- <Address: 0x03, Data: D4>

* LEDC2 (initial value: '0') --- <Address: 0x03, Data: D5>

The ON/OFF setting of each LED driver channel is as follows:

'0': OFF

'1': ON

* FREQCNT (initial value: '0') --- <Address: 0x03, Data: D6>

The switching frequency of a charge pump is set as follows:

'0': 1MHz

'1': 250kHz

When '250kHz' is selected, the flying capacitor of C1, C2 and Cout must be set to 10µF.

c) LED current setting table

The following table lists the current setting values in respective register settings.

Initially, these registers have not been initialized. For this reason, they are not initialized under EN= '0'.

D5	D4	D3	D2	D1	D0	Output current (mA)	D5	D4	D3	D2	D1	D0	Output current (mA)
0	0	0	0	0	0	0.5	1	0	0	0	0	0	16.5
0	0	0	0	0	1	1.0	1	0	0	0	0	1	17.0
0	0	0	0	1	0	1.5	1	0	0	0	1	0	17.5
0	0	0	0	1	1	2.0	1	0	0	0	1	1	18.0
0	0	0	1	0	0	2.5	1	0	0	1	0	0	18.5
0	0	0	1	0	1	3.0	1	0	0	1	0	1	19.0
0	0	0	1	1	0	3.5	1	0	0	1	1	0	19.5
0	0	0	1	1	1	4.0	1	0	0	1	1	1	20.0
0	0	1	0	0	0	4.5	1	0	1	0	0	0	20.5
0	0	1	0	0	1	5.0	1	0	1	0	0	1	21.0
0	0	1	0	1	0	5.5	1	0	1	0	1	0	21.5
0	0	1	0	1	1	6.0	1	0	1	0	1	1	22.0
0	0	1	1	0	0	6.5	1	0	1	1	0	0	22.5
0	0	1	1	0	1	7.0	1	0	1	1	0	1	23.0
0	0	1	1	1	0	7.5	1	0	1	1	1	0	23.5
0	0	1	1	1	1	8.0	1	0	1	1	1	1	24.0
0	1	0	0	0	0	8.5	1	1	0	0	0	0	24.5
0	1	0	0	0	1	9.0	1	1	0	0	0	1	25.0
0	1	0	0	1	0	9.5	1	1	0	0	1	0	25.5
0	1	0	0	1	1	10.0	1	1	0	0	1	1	26.0
0	1	0	1	0	0	10.5	1	1	0	1	0	0	26.5
0	1	0	1	0	1	11.0	1	1	0	1	0	1	27.0
0	1	0	1	1	0	11.5	1	1	0	1	1	0	27.5
0	1	0	1	1	1	12.0	1	1	0	1	1	1	28.0
0	1	1	0	0	0	12.5	1	1	1	0	0	0	28.5
0	1	1	0	0	1	13.0	1	1	1	0	0	1	29.0
0	1	1	0	1	0	13.5	1	1	1	0	1	0	29.5
0	1	1	0	1	1	14.0	1	1	1	0	1	1	30.0
0	1	1	1	0	0	14.5	1	1	1	1	0	0	30.5
0	1	1	1	0	1	15.0	1	1	1	1	0	1	31.0
0	1	1	1	1	0	15.5	1	1	1	1	1	0	31.5
0	1	1	1	1	1	16.0	1	1	1	1	1	1	32.0

(2) Charge pump

a) Description of operations

Pin voltage comparison takes place at Vout control section, and then Vout generation takes place so that the LED cathode voltage with the highest Vf is set to 0.1V. A boost rate is changed automatically to a proper one at the Charge Pump Mode Control section so that operation can take place at possible low boost rate. When the current taken from VBAT exceeds 600mA, the overcurrent limiter is activated and this IC is reset. In addition, if the output voltage falls below 1.5V, this IC is reset for short-circuit at output.

b) Soft start function

BD1606MVV have a soft start function that prevents the rush current.

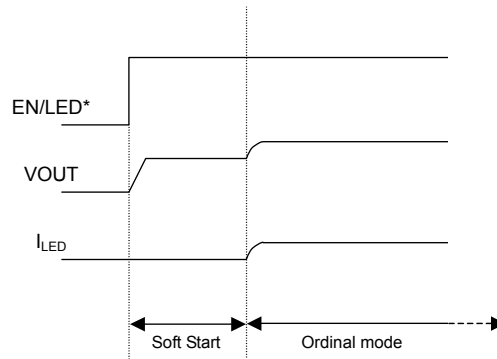

Fig.15 Soft Start

c) Automatic boost rate change

The boost rate automatically switches to the best mode.

* (**×1 mode -> ×1.5 mode**) or (**×1.5 mode -> ×2 mode**)

If a battery voltage drop occurs BD1606MVV cannot maintain the LED constant current, and then mode transition begins.

* (**×1.5 mode -> ×1 mode**) or (**×2 mode -> ×1.5 mode**)

If a battery voltage rise occurs, VOUT and VIN detection are activated, and then mode transition begins.

(3) UVLO (Ultra low Voltage Lock Out)

If the input voltage falls below 2.2V, BD1606MVV is shut down to prevent malfunction due to ultra-low voltage.

(4) OVP (Over Voltage Protection)

This circuit protects this IC against damage when the C/P output voltage (Vout) rises extremely for some external factors.

(5) Thermal shutdown (TSD)

To protect this IC against thermal damage or heat-driven uncontrolled operations, this circuit turns off the output if the chip temperature rises over 150°C. In addition, it turns on the output if the temperature returns to the normal temperature. Because the built-in thermal protection circuit is intended to protect the IC itself, the thermal shutdown detection temperature must be set to below 150°C in thermal design.

●Recommended PCB layout

In PCB design, wire the power supply line in a way that the PCB impedance goes low and provide a bypass capacitor if needed.

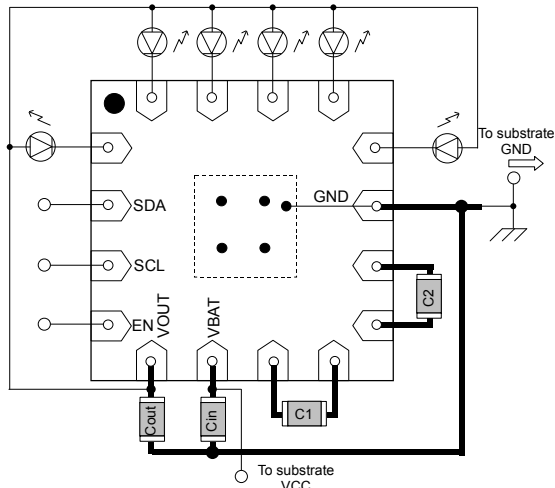

Fig.16 Application Layout Image (Top View)

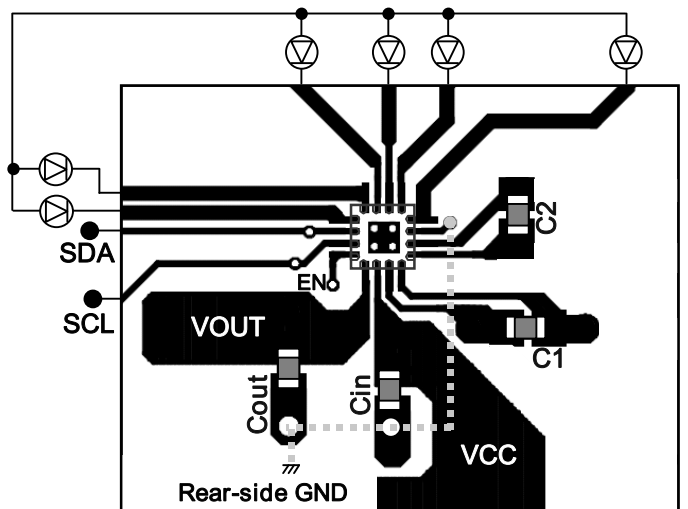

Fig.17 Front (Top View)

●Application Parts Selection Method

Capacitor (Use a ceramics capacitor with good frequency and temperature characteristics.)

Symbol	Recommended value	Recommended parts	Type
Cout,Cin,C1,C2	1μF	GRM188B11A105KA61B(MURATA)	Ceramics capacitor

Connect an input bypass capacitor CIN between VBAT/VIN and GND pin and an output capacitor between VOUT and GND pin in proximity. Place both C1P-C1N and C2P-C2N capacitors in proximity to the chip Furthermore, select a ceramics capacitor with a sufficient rating for voltage to be applied.

When other than these parts are used, the equivalent parts must be used.

● Notes for Use

- (1) Absolute Maximum Ratings
An excess in the absolute maximum ratings, such as supply voltage, temperature range of operating conditions, etc., can break down devices, thus making impossible to identify breaking mode such as a short circuit or an open circuit. If any special mode exceeding the absolute maximum ratings is assumed, consideration should be given to take physical safety measures including the use of fuses, etc.
- (2) Operating conditions
These conditions represent a range within which characteristics can be provided approximately as expected. The electrical characteristics are guaranteed under the conditions of each parameter.
- (3) Reverse connection of power supply connector
The reverse connection of power supply connector can break down ICs. Take protective measures against the breakdown due to the reverse connection, such as mounting an external diode between the power supply and the IC's power supply terminal.
- (4) Power supply line
Design PCB pattern to provide low impedance for the wiring between the power supply and the GND lines. Furthermore, for all power supply terminals to ICs, mount a capacitor between the power supply and the GND terminal. At the same time, in order to use an electrolytic capacitor, thoroughly check to be sure the characteristics of the capacitor to be used present no problem including the occurrence of capacity dropout at a low temperature, thus determining the constant.
- (5) GND voltage
Make setting of the potential of the GND terminal so that it will be maintained at the minimum in any operating state. Furthermore, check to be sure no terminals are at a potential lower than the GND voltage including an actual electric transient.
- (6) Short circuit between terminals and erroneous mounting
In order to mount ICs on a set PCB, pay thorough attention to the direction and offset of the ICs. Erroneous mounting can break down the ICs. Furthermore, if a short circuit occurs due to foreign matters entering between terminals or between the terminal and the power supply or the GND terminal, the ICs can break down.
- (7) Operation in strong electromagnetic field
Be noted that using ICs in the strong electromagnetic field can malfunction them.
- (8) Inspection with set PCB
On the inspection with the set PCB, if a capacitor is connected to a low-impedance IC terminal, the IC can suffer stress. Therefore, be sure to discharge from the set PCB by each process. Furthermore, in order to mount or dismount the set PCB to/from the jig for the inspection process, be sure to turn OFF the power supply and then mount the set PCB to the jig. After the completion of the inspection, be sure to turn OFF the power supply and then dismount it from the jig. In addition, for protection against static electricity, establish a ground for the assembly process and pay thorough attention to the transportation and the storage of the set PCB.
- (9) Input terminals
In terms of the construction of IC, parasitic elements are inevitably formed in relation to potential. The operation of the parasitic element can cause interference with circuit operation, thus resulting in a malfunction and then breakdown of the input terminal. Therefore, pay thorough attention not to handle the input terminals, such as to apply to the input terminals a voltage lower than the GND respectively, so that any parasitic element will operate. Furthermore, do not apply a voltage to the input terminals when no power supply voltage is applied to the IC. In addition, even if the power supply voltage is applied, apply to the input terminals a voltage lower than the power supply voltage or within the guaranteed value of electrical characteristics.
- (10) Ground wiring pattern
If small-signal GND and large-current GND are provided, It will be recommended to separate the large-current GND pattern from the small-signal GND pattern and establish a single ground at the reference point of the set PCB so that resistance to the wiring pattern and voltage fluctuations due to a large current will cause no fluctuations in voltages of the small-signal GND. Pay attention not to cause fluctuations in the GND wiring pattern of external parts as well.
- (11) External capacitor
In order to use a ceramic capacitor as the external capacitor, determine the constant with consideration given to a degradation in the nominal capacitance due to DC bias and changes in the capacitance due to temperature, etc.
- (12) Thermal shutdown circuit (TSD)
When junction temperatures become 175°C (typ) or higher, the thermal shutdown circuit operates and turns a switch OFF. The thermal shutdown circuit, which is aimed at isolating the LSI from thermal runaway as much as possible, is not aimed at the protection or guarantee of the LSI. Therefore, do not continuously use the LSI with this circuit operating or use the LSI assuming its operation
- (13) Thermal design
Perform thermal design in which there are adequate margins by taking into account the permissible dissipation (Pd) in actual states of use.
- (14) Coil selection
To reduce the loss, select a coil with a small wound resistor for DC/DC converter output.

●Ordering part number

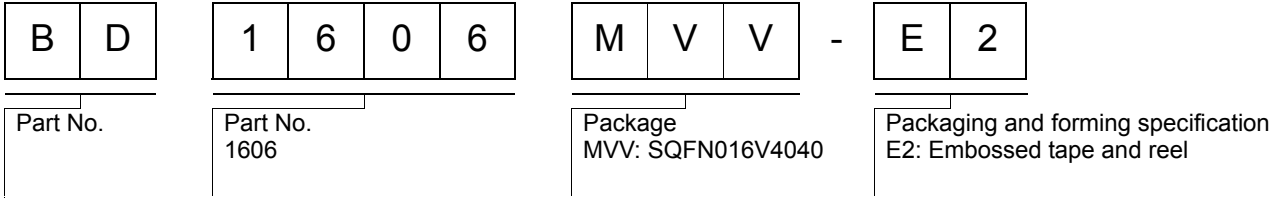

SQFN016V4040

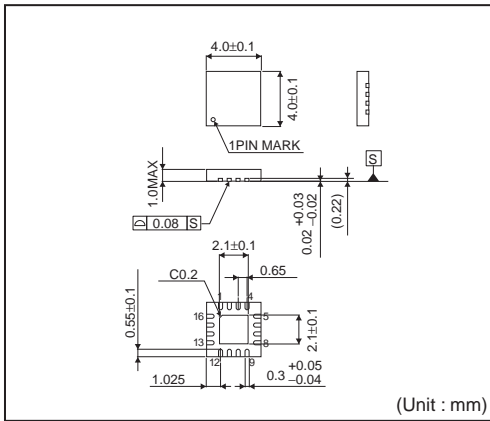

<Tape and Reel information>

Tape	Embossed carrier tape
Quantity	2500pcs
Direction of feed	E2 (The direction is the 1 pin of product is at the upper left when you hold reel on the left hand and you pull out the tape on the right hand)

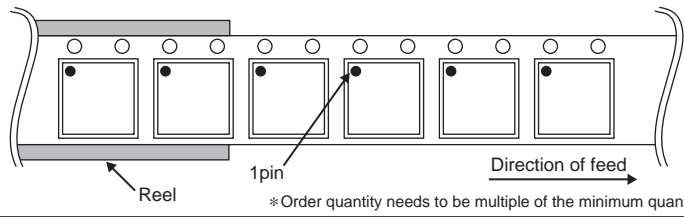

Notes

No copying or reproduction of this document, in part or in whole, is permitted without the consent of ROHM Co.,Ltd.

The content specified herein is subject to change for improvement without notice.

The content specified herein is for the purpose of introducing ROHM's products (hereinafter "Products"). If you wish to use any such Product, please be sure to refer to the specifications, which can be obtained from ROHM upon request.

Examples of application circuits, circuit constants and any other information contained herein illustrate the standard usage and operations of the Products. The peripheral conditions must be taken into account when designing circuits for mass production.

Great care was taken in ensuring the accuracy of the information specified in this document. However, should you incur any damage arising from any inaccuracy or misprint of such information, ROHM shall bear no responsibility for such damage.

The technical information specified herein is intended only to show the typical functions of and examples of application circuits for the Products. ROHM does not grant you, explicitly or implicitly, any license to use or exercise intellectual property or other rights held by ROHM and other parties. ROHM shall bear no responsibility whatsoever for any dispute arising from the use of such technical information.

The Products specified in this document are intended to be used with general-use electronic equipment or devices (such as audio visual equipment, office-automation equipment, communication devices, electronic appliances and amusement devices).

The Products specified in this document are not designed to be radiation tolerant.

While ROHM always makes efforts to enhance the quality and reliability of its Products, a Product may fail or malfunction for a variety of reasons.

Please be sure to implement in your equipment using the Products safety measures to guard against the possibility of physical injury, fire or any other damage caused in the event of the failure of any Product, such as derating, redundancy, fire control and fail-safe designs. ROHM shall bear no responsibility whatsoever for your use of any Product outside of the prescribed scope or not in accordance with the instruction manual.

The Products are not designed or manufactured to be used with any equipment, device or system which requires an extremely high level of reliability the failure or malfunction of which may result in a direct threat to human life or create a risk of human injury (such as a medical instrument, transportation equipment, aerospace machinery, nuclear-reactor controller, fuel-controller or other safety device). ROHM shall bear no responsibility in any way for use of any of the Products for the above special purposes. If a Product is intended to be used for any such special purpose, please contact a ROHM sales representative before purchasing.

If you intend to export or ship overseas any Product or technology specified herein that may be controlled under the Foreign Exchange and the Foreign Trade Law, you will be required to obtain a license or permit under the Law.



Thank you for your accessing to ROHM product informations.
More detail product informations and catalogs are available, please contact us.

ROHM Customer Support System

<http://www.rohm.com/contact/>