

Car alternator multifunction smart voltage regulator

Datasheet - production data

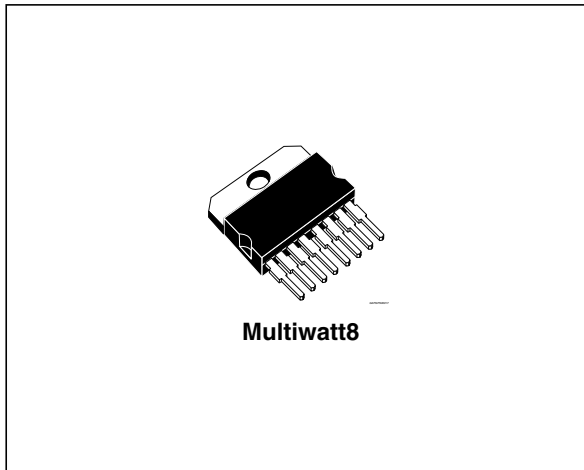

- Thermal protection
- Field short circuit protection
- Protected diagnostic lamp driver
- Protected high side relay driver
- Complex diagnostics
- Load response control
- DFM output (field monitor)
- Self start function

Description

The L9911 is a monolithic multifunction alternator voltage regulator intended for use in automotive application.

It includes the control section, the field power stage, fault diagnostic circuit which drives a warning lamp, and the protection against short circuits

Features

- Fully monolithic design
- High side field driver

Table 1. Device summary

Order code	Temp. range, °C	Package	Packing
L9911F	$T_j = -40$ to $+150$	Multiwatt8	Tube
L9911I			
L9911P			
L9911V			
L9911K			
L9911U			

Contents

1	Circuit operation	5
1.1	Voltage regulation	5
1.2	Protection	5
1.3	Diagnosis	5
1.4	Load response control	5
1.5	Self start function	5
2	Pin description	6
3	Electrical specification	7
3.1	Absolute maximum ratings	7
3.2	Thermal data	7
3.3	Electrical characteristics	7
3.4	Principle of phase regulation	14
4	Package information	17
4.1	Multiwatt 8 (pin 5 GND) package information	17
5	Revision history	19

List of tables

Table 1.	Device summary	1
Table 2.	Pin description	6
Table 3.	Absolute maximum ratings	7
Table 4.	Thermal data	7
Table 5.	Electrical characteristics	7
Table 6.	Load response control parameters	10
Table 7.	Load response control timing options	10
Table 8.	Correspondence of frequency (typical values) to application features	11
Table 9.	Customization of L9911: combination of LRC, regulation, and application options	11
Table 10.	Fault detection	16
Table 11.	Multiwatt 8 (pin 5GND) package mechanical drawing	18
Table 12.	Document revision history	19

List of figures

Figure 1.	Pin connection (top view)	6
Figure 2.	V_{reg-1}	11
Figure 3.	V_{reg-2}	12
Figure 4.	V_{reg-3}	12
Figure 5.	V_{reg-4}	13
Figure 6.	Output voltage rise/fall time (F+, DFM)	13
Figure 7.	Phase regulation characteristics	13
Figure 8.	Application diagram	14
Figure 9.	High side/low side driver saturation	14
Figure 10.	Test mode to cancel soft-start/attack	14
Figure 11.	Soft-start enable frequency range	14
Figure 12.	Soft-start characteristics (always activated at engine start)	15
Figure 13.	Soft start/attack characteristics	15
Figure 14.	DF monitor electrical configuration	16
Figure 15.	Short circuit drivers' protection	16
Figure 16.	Multiwatt 8 (pin 5GND) package outline	17

1 Circuit operation

The alternator's voltage regulator performs the following main functions:

1. voltage regulation
2. protection
3. control fault diagnosis
4. load response control

1.1 Voltage regulation

The alternator voltage is compared with a reference voltage in an amplifier, whose output determines the switching frequency of output power MOS whose current excites the coil of the alternator; as the regulator is in fixed-frequency topology, the field switching frequency does not depend on the alternator characteristics. The regulators have an integrated filter in the voltage sensing path guaranteeing the correct behaviour of the devices also when the rectifier diodes feature very high switching spikes. The internal filtering allows the usage of the device also with very long cables connecting the alternator to the battery with an impedance so high to cause a superimposed ripple on the alternator voltage higher than 5-6 V. Consequently it doesn't need, in the standard application, any external component. Anyway an external capacitor (2.2 μ F) must be inserted between A+ and ground when using the device with very long cables.

1.2 Protection

It is present a protection against short circuits of the lamp and the relay power drivers (L) and of the field power driver (F+), a thermal drivers shutdown protection and an overvoltage protection of L power drivers.

1.3 Diagnosis

The circuit detects fault conditions related to the phase and F+ status and receives informations from one of the three alternator phases. In order to prevent spurious indications, fault warnings are not displayed immediately but are delayed by a fixed time.

1.4 Load response control

The internal circuit regulates the soft start characteristics (activated always at engine start) and the soft attack characteristics.

1.5 Self start function

The device wakes up by the phase signal only. The phase signal must have a voltage amplitude higher than VPHL1 and a frequency higher than EN-x.

2 Pin description

Figure 1. Pin connection (top view)

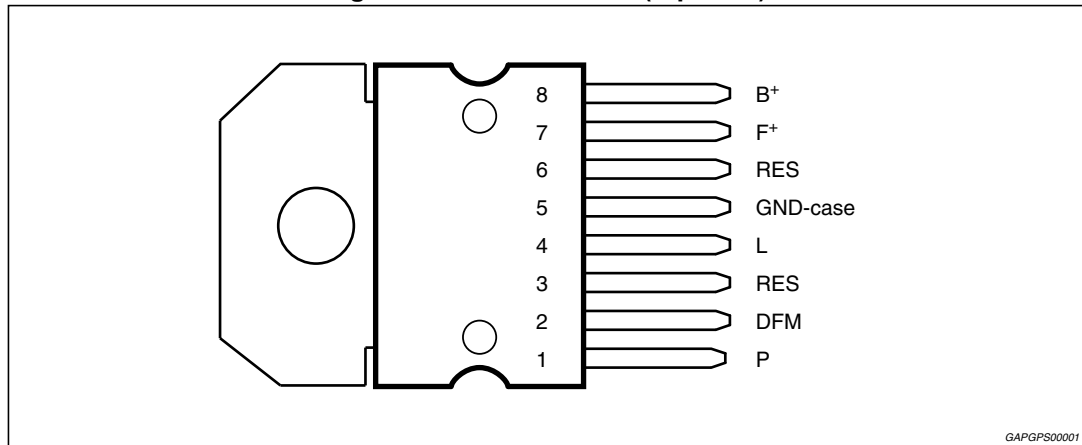

Table 2. Pin description

N°	Pin	Function
1	P	Phase sense input.
2	DFM	Field monitor output.
3	RES	Reserved.
4	L	Lamp terminal low side driver; relay terminal high side driver.
5	GND-case	Ground.
6	RES	Reserved.
7	F ⁺	High side driver output.
8	B ⁺	Sensed power supply.

3 Electrical specification

3.1 Absolute maximum ratings

$T_j = -40$ to 150 °C, unless otherwise specified.

Table 3. Absolute maximum ratings

Symbol	Parameter	Value	Unit
V_S	DC supply voltage (2 min. @ 25 °C)	24	V
-	Transient supply voltage (load dump) [see Figure 8] $t < 500$ ms	40	V
-	Transient supply voltage (low energy spikes) (see Figure 8) ISO7637-1 pulse 1,2,3 /ISO7637-3	60	V
T_j	Junction temperature range	-40 to 150	°C
T_{stg}, T_{case}	Storage and case temperature range	-40 to 150	°C
P_{tot}	Total power dissipation (@ $T_{case} \leq 150$ °C, $I_{field} \leq 5$ A)	4	W
-	Reverse battery voltage (see Figure 8) @ 25°C, $T = 15$ sec.	-2.5	V
-	Normal working condition reverse voltage (P vs. GND)	-1.5	V
-	DC pin current on F+, B+, GND (bonding limitation)	15	A
-	ESD voltage MILSTD883C (All pins vs.GND)	± 4	KV

3.2 Thermal data

Table 4. Thermal data

Symbol	Parameter	Value	Unit
$R_{th j-case}$	Thermal resistance junction-to-case	≤ 1.5	°C/W

3.3 Electrical characteristics

$T_j = -40$ °C to 150 °C; unless otherwise specified.

Table 5. Electrical characteristics

Symbol	Parameter	Test condition	Min.	Typ.	Max.	Unit
V_{bat}	Operating supply voltage	-	7	-	18	V
$I_{b-sinked}$	Supply battery current	-	-	-	25	mA
I_{b-stby}	Standby current	B+ = 12.5 V, F+ = 0 V	-	-	500	μ A

Table 5. Electrical characteristics (continued)

Symbol	Parameter	Test condition	Min.	Typ.	Max.	Unit
V _{reg 1}	Regulated voltage & thermal drift. 3 configurations available, selectable by mask option (see Table 8).	I _{alt} = 1 A~0.9 · I _{nom} ; T _{case} = 20 °C; 1400 < rpm < RPMMAX (see Figure 2)	14.0 -4.5	14.4 -3.5	14.8 -2.5	V mV/°C
V _{reg 2}		I _{alt} = 10 A; T _{case} = 23 °C; rpm = 6000 rpm; 15 V max. (see Figure 3)	14.35 -11.8	14.5 -10	14.65 -8.2	V mV/°C
V _{reg 3}		I _{alt} = 10 A; T _{case} = 23 °C; rpm = 6000 rpm (see Figure 4)	14.35 -6	14.5 -4	14.65 -2	V mV/°C
V _{reg 4}		I _{alt} = 10 A; T _{case} = 23 °C; rpm = 6000 rpm (see Figure 5)	13.95 -3.5	14.2 -2.5	14.3 -1.5	V mV/°C
ΔV _{rpm}	-	1400 < rpm < RPMMAX; I _{alt} = 10 A	-	-	200	mV
ΔV _{load}	-	5 A < I _{alt} < I _{nom} ; rpm = 6000 rpm	-	-	250	mV
V _{reg-less}	Reg. voltage without battery	I _{alt} = 3 A resistive; T _{case} = 25 °C; 2000 < rpm < RPMMAX	12	-	16	V
V _{ov-p}	Overvoltage protection threshold	Voltage on pin B+ to disable L drivers High and low side driver off	18	-	22	V
V _{ov-d}	Overvoltage diagnosis threshold	VB+ to turn on L low side driver at VF+ > VS1	Vreg - 5%	Vreg	Vreg + 5%	V
T _{j-sd}	Thermal shutdown threshold	Temperature to disable F+, DFM, L (high & low side drivers)	160	175	190	°C
T _{j-sd-dwn}	Thermal shut-down hysteresis	L/F+/DFM from OFF STATE (due to thermal shutdown) to ON STATE	Tj-sd-10	-	Tj-sd-2	°C
V _{uv-1}	Under voltage diagnosis threshold	VB+ to turn on L low side driver	7.7	8.6	9.5	V
V _{uv-up}		VB+ to turn off L low side driver	Vuv + 0.40	Vuv + 0.75	Vuv + 1.2	V
V _{F+_sat}	Field driver saturation voltage	T _j = 150 °C; I = 4.5 A	-	-	0.6	V
		T _j = 25 °C; I = 7 A	-	-	0.55	V
V _f	Freewheeling diode F+	I = 5 A	-	-	2	V
I _{f_SCTH}	Field short circuit driver protection threshold current (see Figure 15)	F+ = 0 V; T _j = -40 °C	11	-	18	A
		F+ = 0 V; T _j = -25 °C	9.5	-	18	A
		F+ = 0 V; T _j = -150 °C	9	-	18	A
V _{s1}	Field driver ON-state detection	-	4.5	-	5.5	V
f _{pre}	Pre-excitation frequency	-	283	333	383	Hz
Duty-pre	Pre-excitation Field driver ON-duty	-	15.93	18.75	21.57	%
t _r	Output voltage rise time	I _{field} = 3 A resistive see Figure 6)	10	-	50	μs
t _f	Output voltage fall time		10	-	50	μs
F _{sw_F+}	Field switching frequency	I _{alt} = 1 A~0.9 · I _{nom} ; 1400 rpm < rpm < RPMMAX	250	-	400	Hz

Table 5. Electrical characteristics (continued)

Symbol	Parameter	Test condition	Min.	Typ.	Max.	Unit
If_leak	Output field driver leakage current	B+ = 24 V; V _{F+} = 0	-	-	10	μA
DUTY-PR	Phase regulation max field ON duty	see <i>Figure 7</i>	26.56	31.25	35.94	%
V _{H_SAT}	High side driver saturation Voltage (see <i>Figure 9</i>)	With driver I _{source} = 500 mA	-	-	1.5	V
V _{L_SAT}	Low side driver saturation voltage (see <i>Figure 9</i>)	With driver I _{sink} = 500 mA	-	-	1.5	V
V _{LSB}	Self bias without supply lamp driver voltage	B+ open; L connected to 12 V through a 50 Ohm resistor	-	-	4	V
I _{HSC}	High side driver short circuit current protection	B+ = 12.5 V; L = GND	1.2	-	3	A
I _{LSC}	Low side driver short circuit current (see <i>Figure 15</i>)	B+ = L = 12.5 V	1	-	2	A
V _{thL}	Enable regulator supply voltage threshold	-	0.8	-	1.15	V
I _{pd_L}	L terminal pull-down current when the generator is not rotating	V _L = 0.6 V	0.4	-	3.5	mA
I _{L_sink}	L sink current when the generator is rotating	P frequency 500 Hz; V _{B+} = 12 V	-	-	100	μA
t _D	Diagnostic alarm delay time	-	0.2	-	0.5	s
V _{can-DFM}	Test mode to cancel soft start/attack (voltage)	(see <i>Figure 10</i>)	30	-	50	V
t _{can-DFM}	Test mode delay time		25	-	-	ms
V _{PHL1}	Enable control voltage input high threshold	-	-	-	0.40	V
V _{PHL2}	Enable control voltage input low threshold	-	-	-	0.25 ⁽¹⁾	V
t _{PHL1}	Enable Control Voltage Phase Filtering Time	-	50	-	115	μs
V _{PHH1}	Diagnosis phase loss input high threshold	-	8	9	10	V
V _{PHH2_1}	Diagnosis phase loss input low threshold	-	6.4	7.4	8.4	V
t _{PHd}	Diagnostic phase filtering time	-	50	-	100	μs
I _{Pd-P1}	Phase pull-down current	VP = 0.8 V	1	-	8	mA
f _{-dfm}	DFM output open drain switching freq.	I _{alt} = 1 A ~ 0.9 · I _{nom} ; 1400 rpm < rpm < RPMMAX; I _{sink} = 4 mA	125	-	200	Hz
V _{L-DFM}	Output low voltage saturation	I _{-sink} = 14 mA	-	-	1.5	V
I _{SC-DFM}	Short circuit current protection	VB+ = VDFM = 12.5 V	50	-	400	mA
I _{lk-DFM}	Output leakage current	V _{DFM} = 16 V at DFM driver OFF	-	-	5	μA

Table 5. Electrical characteristics (continued)

Symbol	Parameter	Test condition	Min.	Typ.	Max.	Unit
t _{TM}	Output voltage rise time	R = 1 kΩ (see <i>Figure 6</i>)	0.5	-	50	μs
t _{TD}	Output voltage fall time		0.5	-	50	

1. Guaranteed by design.

Table 6. Load response control parameters

Symbol	Parameter	Test Condition	Min.	Typ.	Max.	Unit
t _{ST_1}	Soft start delay time (see <i>Figure 12</i>) 2 steps available, selectable by mask option (see <i>Table 7</i>).	Activated always at engine start	-	0-	-	s
t _{ST_2}			1.73	2	2.35	s
t _{SL_1}	Soft attack time / soft start time (see <i>Figure 12</i>). 2 steps available, selectable by mask option (see <i>Table 7</i>).	From 0 to 100 % field duty cycle	2.13	2.5	2.87	s
t _{SL_2}			7.65	9	10.35	
EN-RES (constant)	Reset frequency range to enable regulation; Frequency judged after 4 periods (see <i>Figure 11</i>)	-	40	50	60	Hz
EN-1	Soft start enable (EN) and LRC disable (DISAB) frequency ranges. 4 configurations available, selectable by mask option (possible combinations in <i>Table 8</i>). Always activated at engine start. Frequencies judged after 4 periods (see <i>Figure 11</i>)	T _j = 25 °C	108	120	132	Hz
		T _j = -40 to 150 °C	102	120	138	Hz
EN-2		T _j = 25 °C	131	145	159	Hz
		T _j = -40 to 150 °C	124	145	166	Hz
EN-3		T _j = 25 °C	144	160	176	Hz
		T _j = -40 to 150 °C	136	160	184	Hz
EN-4		T _j = 25 °C	174	193	212	Hz
		T _j = -40 to 150 °C	165	193	221	Hz
DISAB-1		T _j = 25 °C	270	300	330	Hz
		T _j = -40 to 150 °C	255	300	345	Hz
DISAB-2		T _j = 25 °C	315	350	385	Hz
		T _j = -40 to 150 °C	298	350	402	Hz
DISAB-3		T _j = 25 °C	367	408	449	Hz
		T _j = -40 to 150 °C	347	408	469	Hz
DISAB-4		T _j = 25 °C	420	466	512	Hz
		T _j = -40 to 150 °C	397	466	535	Hz

Table 7. Load response control timing options

-	t _{SL} = 2.5 s	t _{SL} = 9 s
t _{ST} = 0 s	LRC-A	LRC-D
t _{ST} = 0.5 s	LRC-C	-
t _{ST} = 2 s	LRC-E	LRC-B

Table 8. Correspondence of frequency (typical values) to application features

Alternator revolution speed (rpm)			6 pole pairs	8 pole pairs
Typical configuration A (Config-A)	Initiate regulation	1200	EN-1	EN-3
	LRC Cut	3000	DISAB-1	DISAB-3
Typical configuration B (Config-B)	Initiate Regulation	1450	EN-2	EN-4
	LRC Cut	3000	DISAB-1	DISAB-3
Typical configuration C (Config-C)	Initiate Regulation	1450	EN-2	EN-4
	LRC Cut	3500	DISAB-2	EN-4

Considering the overall WW application scenario, there is a direct correspondence between Typical configurations A/B and regulation curve Vreg-1, and between typical configuration C and regulation curves V_{reg-2} and V_{reg-3}. This is allowing the summary of all possible customization for L9911 in the table below.

Table 9. Customization of L9911: combination of LRC, regulation, and application options

LRC timing options	Vreg-1/Config-A		Vreg-1/Config-B		Vreg-2/Config-B		Vreg-2/Config-A		Vreg-4/Config-A	
	6 Pole Pairs	8 Pole Pairs	6 Pole Pairs	8 Pole Pairs	6 Pole Pairs	8 Pole Pairs	6 Pole Pairs	8 Pole Pairs	6 Pole Pairs	8 Pole Pairs
LRC-A	L9911P	nya	nya	nya	nya	nya	nya	nya	L9911K	nya
LRC-B	nya	nya	L9911F	nya	L9911I	nya	nya	nya	nya	nya
LRC-C	nya	nya	nya	nya	nya	nya	L9911V	nya	nya	nya
LRC-D	nya	nya	nya	nya	nya	nya	nya	nya	nya	nya
LRC-E	L9911U	nya	nya	nya	nya	nya	nya	nya	nya	nya

Figure 2. V_{reg-1}

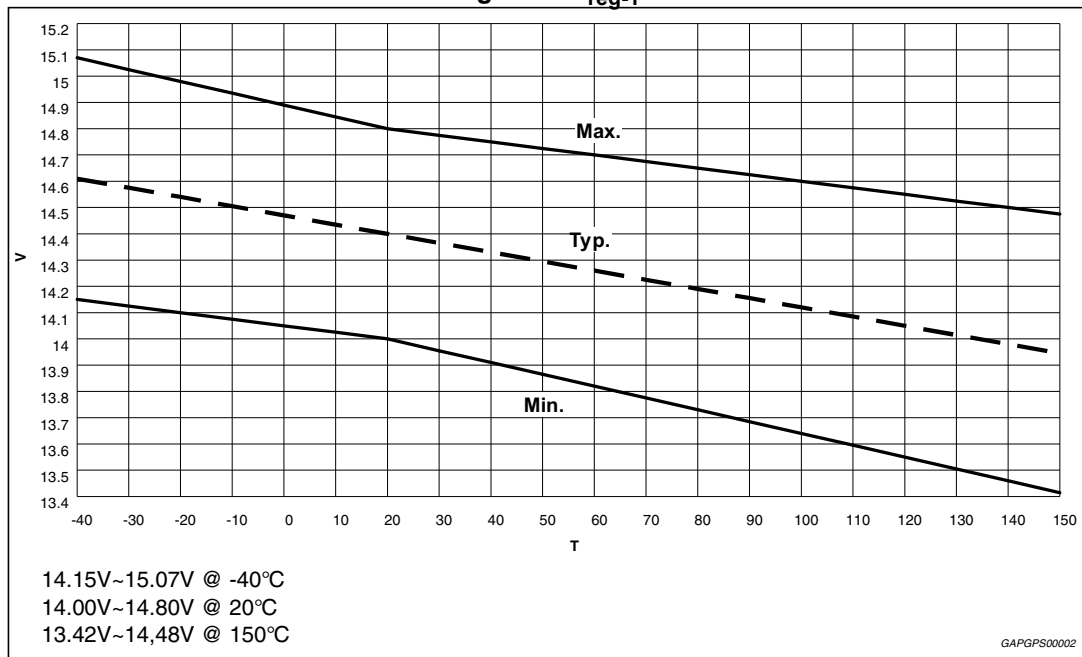

Figure 3. V_{reg-2}

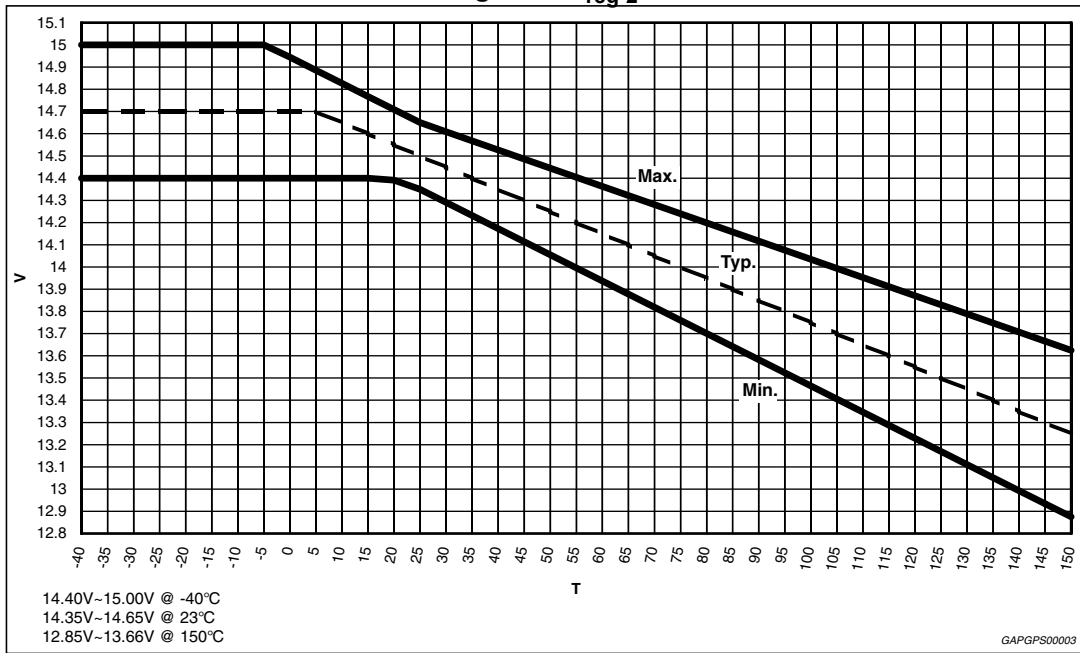

Figure 4. V_{reg-3}

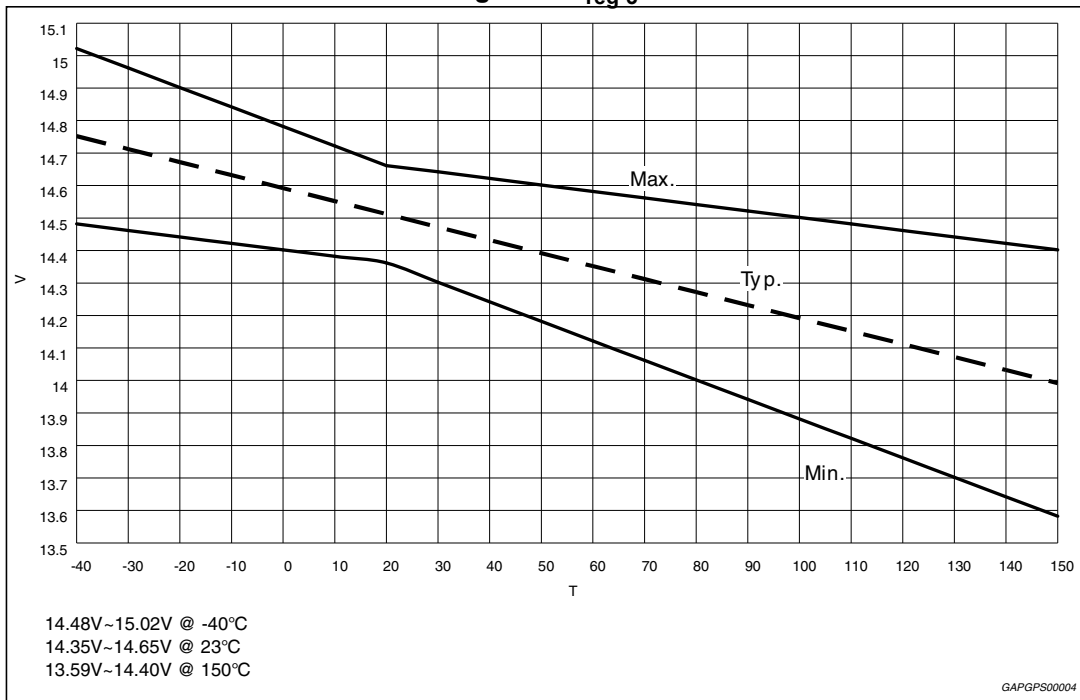

Figure 5. V_{reg-4}

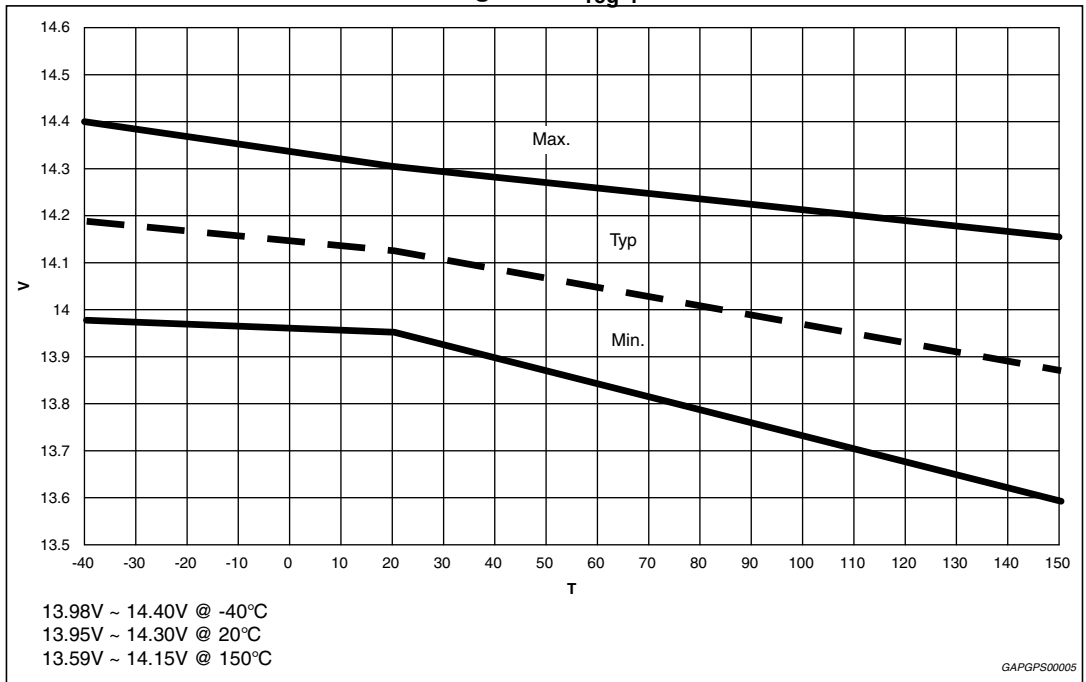

Figure 6. Output voltage rise/fall time (F+, DFM)

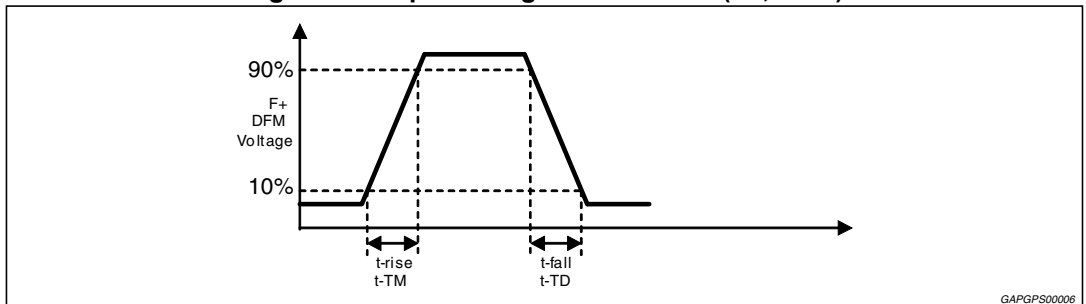
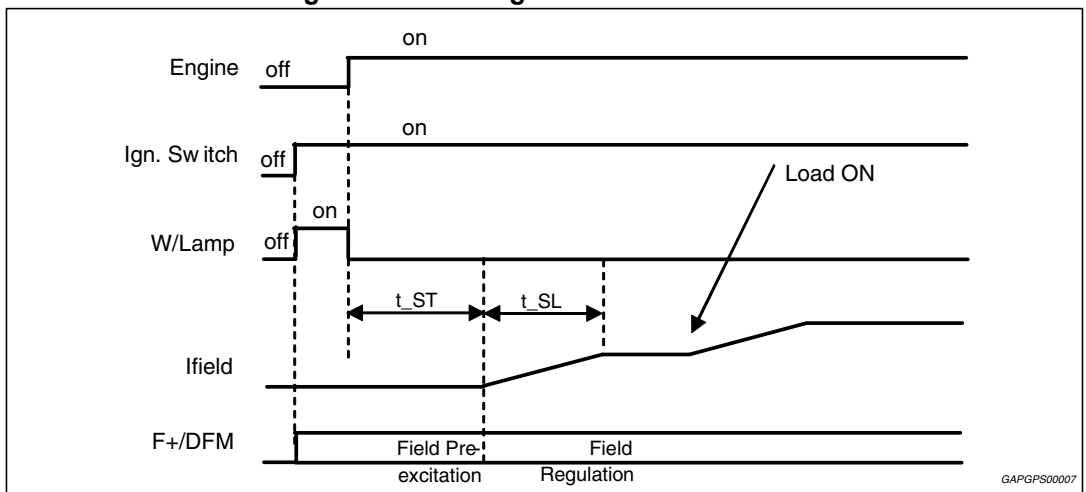

Figure 7. Phase regulation characteristics



3.4 Principle of phase regulation

When V_{B+} is above the regulated voltage, the field driver is controlled to keep phase peak voltage from falling below V_{PHH1} .

If phase peak voltage drops below V_{PHL1} , phase regulation does not work.

Figure 8. Application diagram

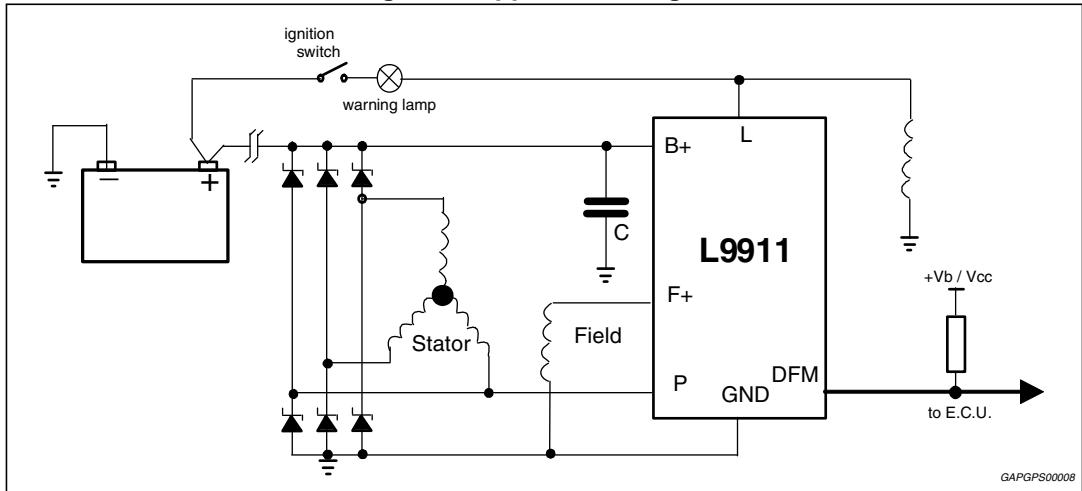

Figure 9. High side/low side driver saturation

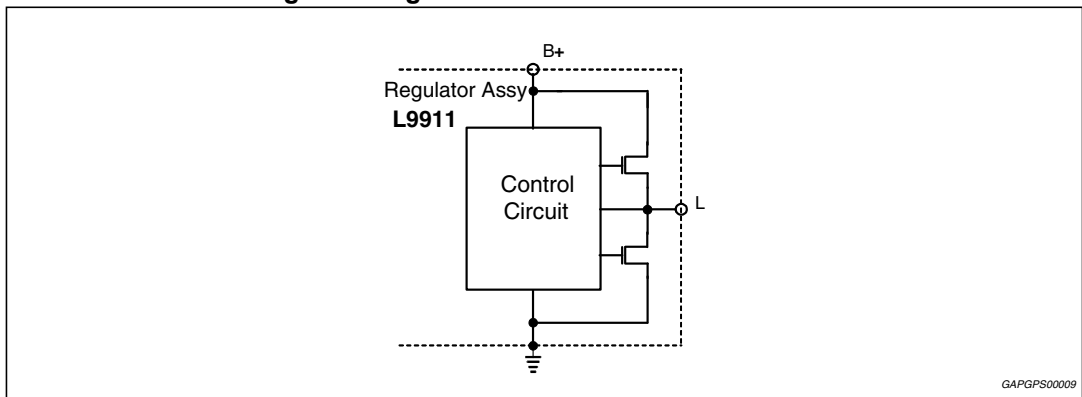

Figure 10. Test mode to cancel soft-start/attack

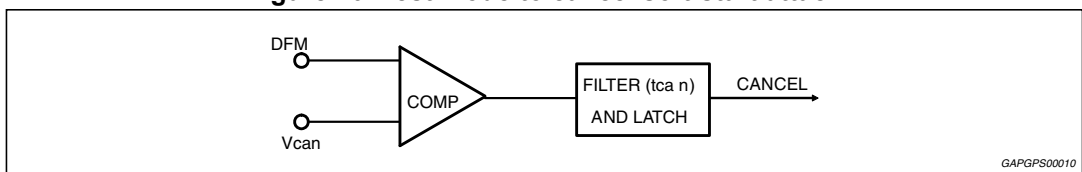

Figure 11. Soft-start enable frequency range

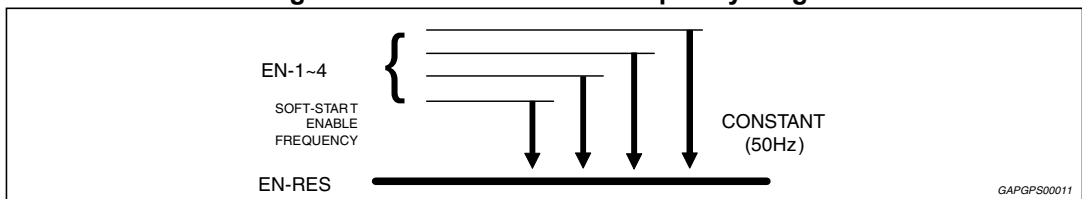

Figure 12. Soft-start characteristics (always activated at engine start)

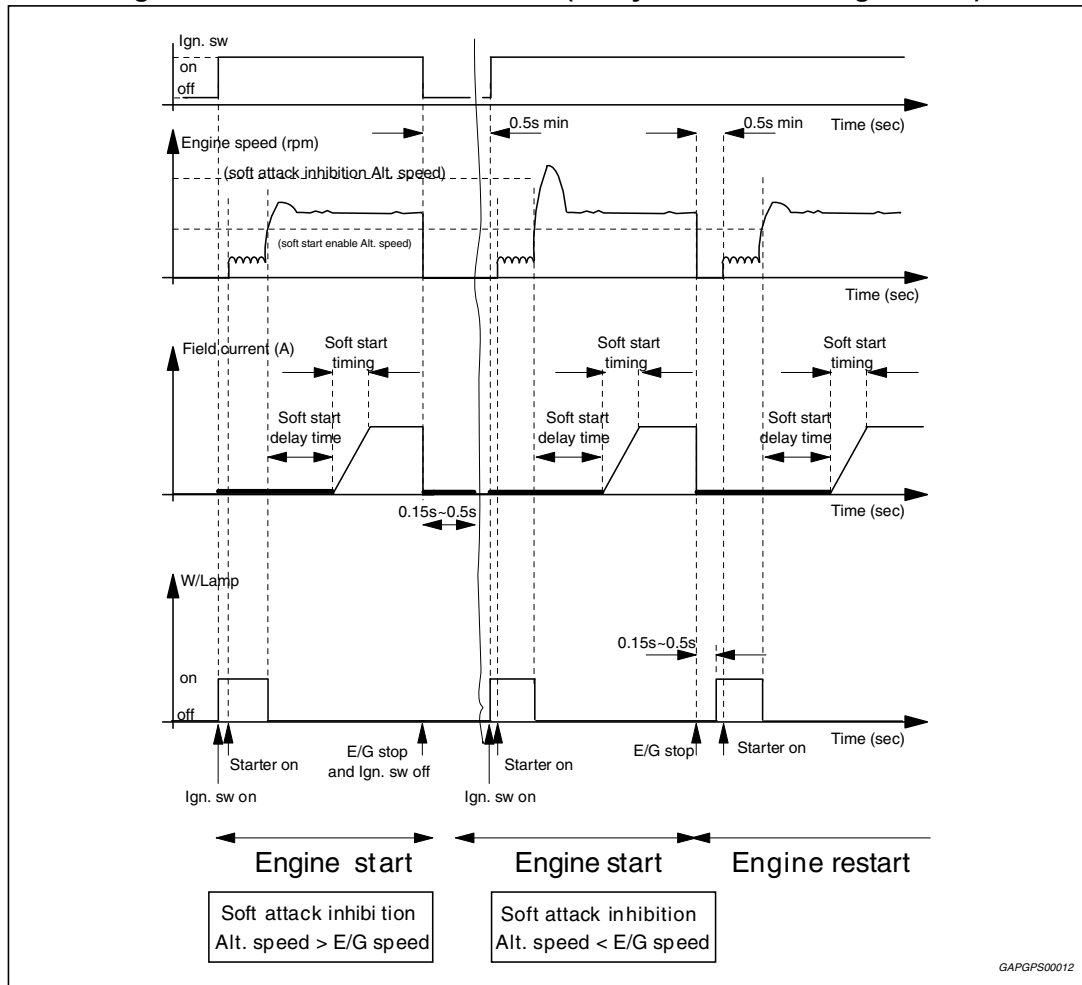

Figure 13. Soft start/attack characteristics

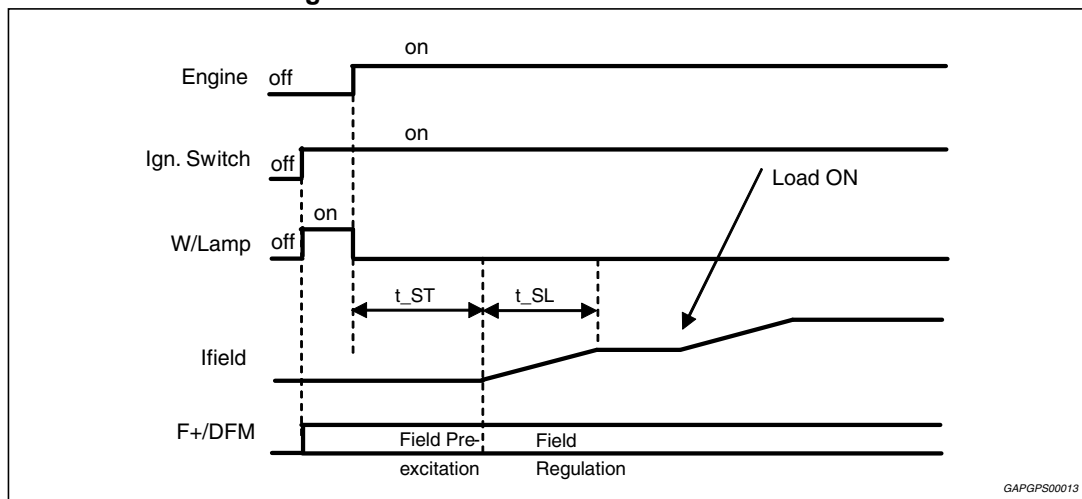

Table 10. Fault detection

Root cause	Signal	Effect	Test detect
Alternator belt breaking	P	Alternator disexcitation	$VP < VP_{HH1}$ & $VB+ < V_{reg}$
Brushes open	P	Alternator disexcitation	$VP < VP_{HH1}$ & $VB+ < V_{reg}$
Field driver open	P	Alternator disexcitation	$VP < VP_{HH1}$ & $VB+ < V_{reg}$
Field interruption	P	Alternator disexcitation	$VP < VP_{HH1}$ & $VB+ < V_{reg}$
Field short circuit to the battery	F+	Overvoltage	$VF+ > VS1$ & $VB+ > V_{ov-d}$
Field short circuit to the ground	P	Alternator disexcitation	$VP < VP_{HH1}$ & $VB+ < V_{reg}$
Battery discharge	B+	Undervoltage	$VB+ < V_{uv}$

Note: The diagnostic result is disabled during the Soft-start delay time $t_{ST} 0...3$ and the soft-start / soft attack timing $t_{SL} 0...3$

Figure 14. DF monitor electrical configuration

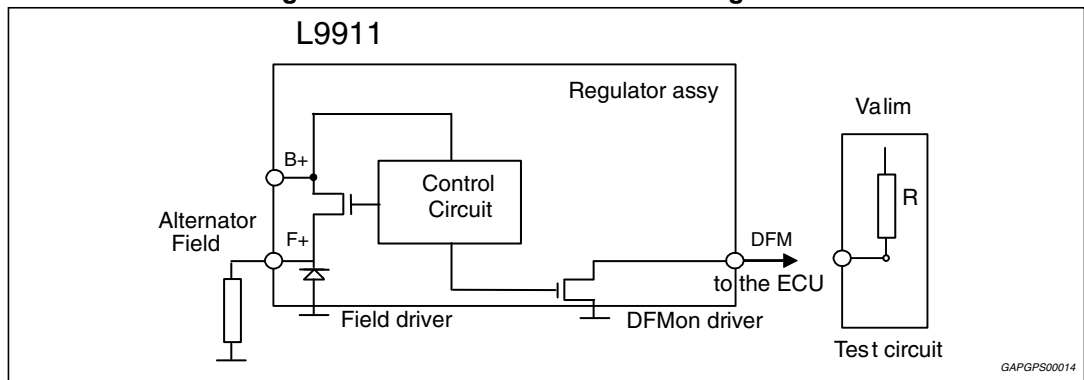
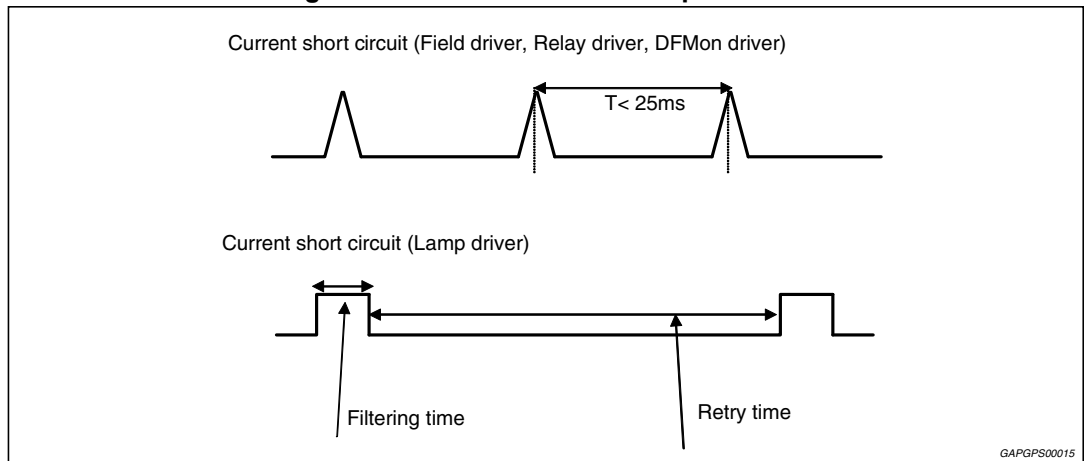

Figure 15. Short circuit drivers' protection



Field driver, DFMon driver and Relay driver are protected in switching mode (not linear), with a retry time less than 25 ms.

Lamp driver is protected in linear mode, with a retry time of 1 s.

4 Package information

In order to meet environmental requirements, ST offers these devices in different grades of ECOPACK[®] packages, depending on their level of environmental compliance. ECOPACK[®] specifications, grade definitions and product status are available at: www.st.com. ECOPACK[®] is an ST trademark.

4.1 Multiwatt 8 (pin 5 GND) package information

Figure 16. Multiwatt 8 (pin 5GND) package outline

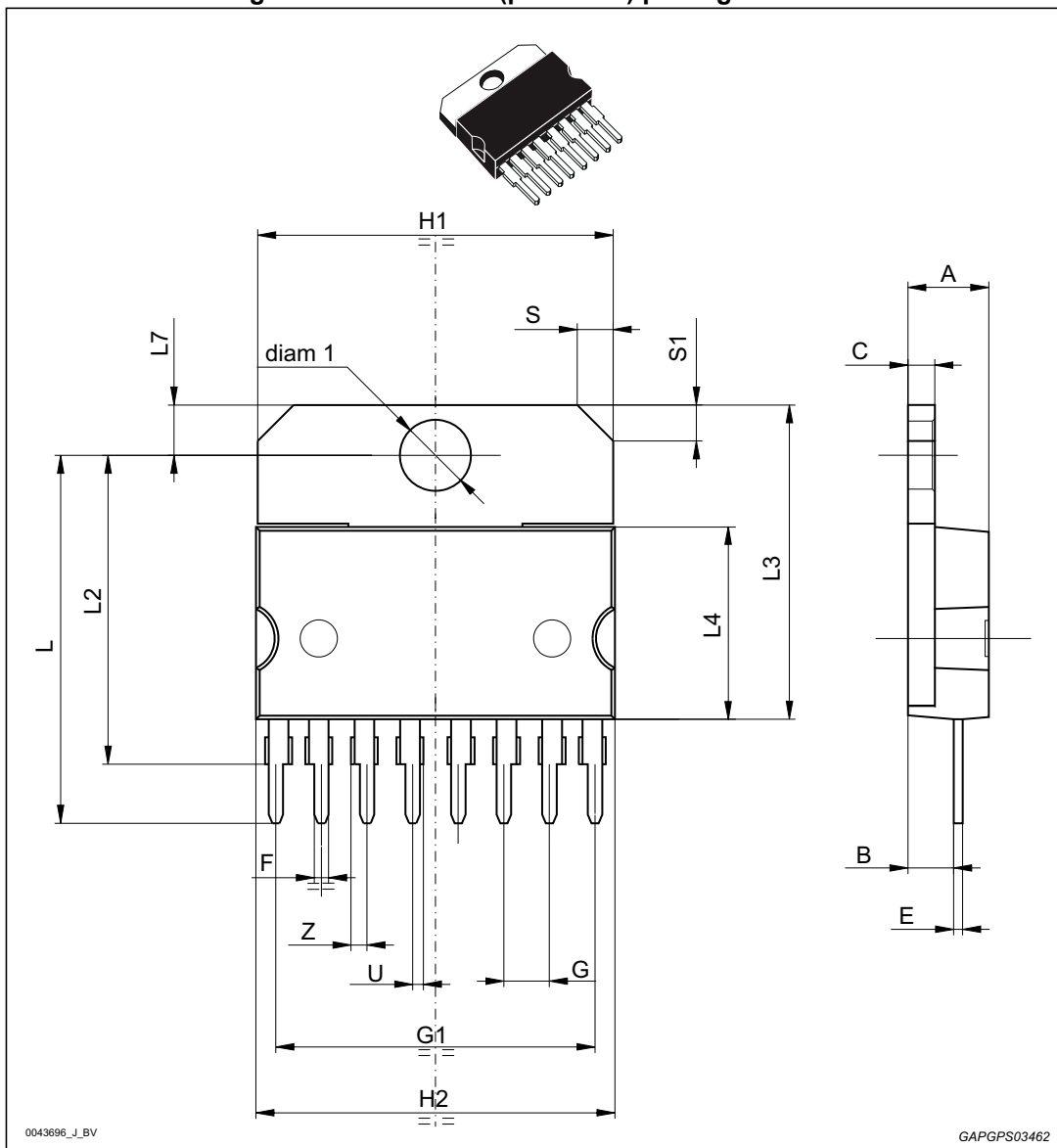

Table 11. Multiwatt 8 (pin 5GND) package mechanical drawing

Ref	Dimensions					
	Millimeters			Inches ⁽¹⁾		
	Min.	Typ.	Max.	Min.	Typ.	Max.
A	-	-	5	-	-	0.1969
B	-	-	2.65	-	-	0.1043
C	-	-	1.6	-	-	0.0630
E	0.49	-	0.55	0.0193	-	0.0217
F	0.78	-	0.85	0.0307	-	0.0335
G	2.40	2.54	2.68	0.0945	0.1000	0.1055
G1	17.64	17.78	17.92	0.6945	0.7000	0.7055
H1	19.6	-	-	0.7717	-	-
H2	-	-	20.2	-	-	0.7953
L	20.35		20.65	0.8012		0.8130
L2	17.05	17.20	17.35	0.6713	0.6772	0.6831
L3	17.25	17.5	17.75	0.6791	0.6890	0.6988
L4	10.3	10.7	10.9	0.4055	0.4213	0.4291
L7	2.65	-	2.9	0.1043	-	0.1142
S	1.9	-	2.6	0.0748	-	0.1024
S1	1.9	-	2.6	0.0748	-	0.1024
U	0.40	-	0.55	0.0157	-	0.0217
Z	0.70	-	0.85	0.0276	-	0.0335
diam1	3.65	-	3.85	0.1437	-	0.1516

1. Values in inches are converted from mm and rounded to 4 decimal digits.

5 Revision history

Table 12. Document revision history

Date	Revision	Changes
22-Jun-2004	1	Initial release.
18-May-2005	2	Modified Figure 2, Table 2 and Table 5; Updated Figure 10, 11 and 14; Add Table 7. Add ordering numbers.
07-Nov-2005	3	Updated Table 5. Added new tables 6-9.
28-Nov-2005	4	Added the L9911C part number. Updated the Table 9.
11-Jul-2007	5	Document reformatted. Updated order codes, see <i>Table 1: Device summary</i> .
09-Nov-2009	6	Updated <i>Table 1: Device summary</i> , <i>Table 7: Load response control timing options</i> and <i>Table 9: Customization of L9911: combination of LRC, regulation, and application options</i> .
23-Jul-2010	7	Updated <i>Table 1: Device summary</i> , <i>Table 5: Electrical characteristics</i> and <i>Table 9: Customization of L9911: combination of LRC, regulation, and application options</i> . Updated <i>Figure 2, 3 and 4</i> . Added new <i>Figure 5</i> .
25-Jan-2011	8	Updated <i>Table 5: Electrical characteristics</i> . Updated <i>Figure 5</i> .
29-Mar-2011	9	Modified in the <i>Table 5: Electrical characteristics</i> the values of the "V _{uv-up} " parameter.
26-Mar-2012	10	Updated: <i>Table 1: Device summary on page 1</i> ; <i>Table 7: Load response control timing options on page 10</i> ; <i>Table 9: Customization of L9911: combination of LRC, regulation, and application options on page 11</i> .
28-May-2012	11	Updated <i>Table 9: Customization of L9911: combination of LRC, regulation, and application options on page 11</i> .
19-Sep-2013	12	Updated disclaimer.
30-Sep-2015	13	Added <i>Section 1.5: Self start function on page 5</i> .

IMPORTANT NOTICE – PLEASE READ CAREFULLY

STMicroelectronics NV and its subsidiaries (“ST”) reserve the right to make changes, corrections, enhancements, modifications, and improvements to ST products and/or to this document at any time without notice. Purchasers should obtain the latest relevant information on ST products before placing orders. ST products are sold pursuant to ST’s terms and conditions of sale in place at the time of order acknowledgement.

Purchasers are solely responsible for the choice, selection, and use of ST products and ST assumes no liability for application assistance or the design of Purchasers’ products.

No license, express or implied, to any intellectual property right is granted by ST herein.

Resale of ST products with provisions different from the information set forth herein shall void any warranty granted by ST for such product.

ST and the ST logo are trademarks of ST. All other product or service names are the property of their respective owners.

Information in this document supersedes and replaces information previously supplied in any prior versions of this document.

© 2015 STMicroelectronics – All rights reserved