



LG1602 Decision Circuit

Features

- Operation up to 3 Gbits/s
- Good sensitivity to low input signals
- Low power dissipation
- Surface-mount package

Applications

- SONET/SDH transmission systems
- Digital video transmission
- Digital test instruments

Functional Description

The LG1602 is a gallium arsenide (GaAs) decision circuit. It features a sensitive broadband input amplifier and a D-type flip-flop that retimes and regenerates an input data stream that is weakened by noise, jitter, and intersymbol interference.

The LG1602 has complementary 50 Ω output buffers.

dc feedback ensures input threshold control for input levels as low as 25 mV, when using dc balanced input data. The LG1602 is available in a hermetically sealed 16-lead glass-metal surface-mount package.

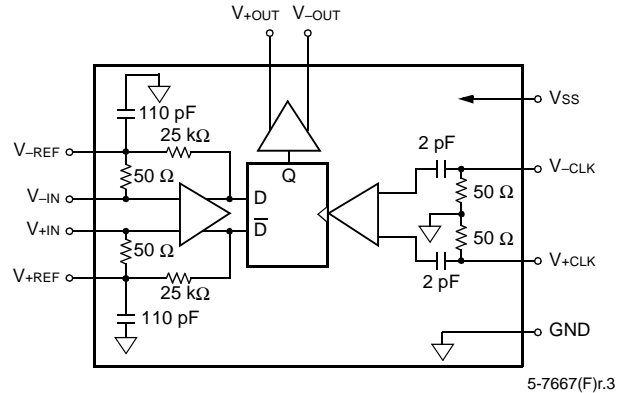
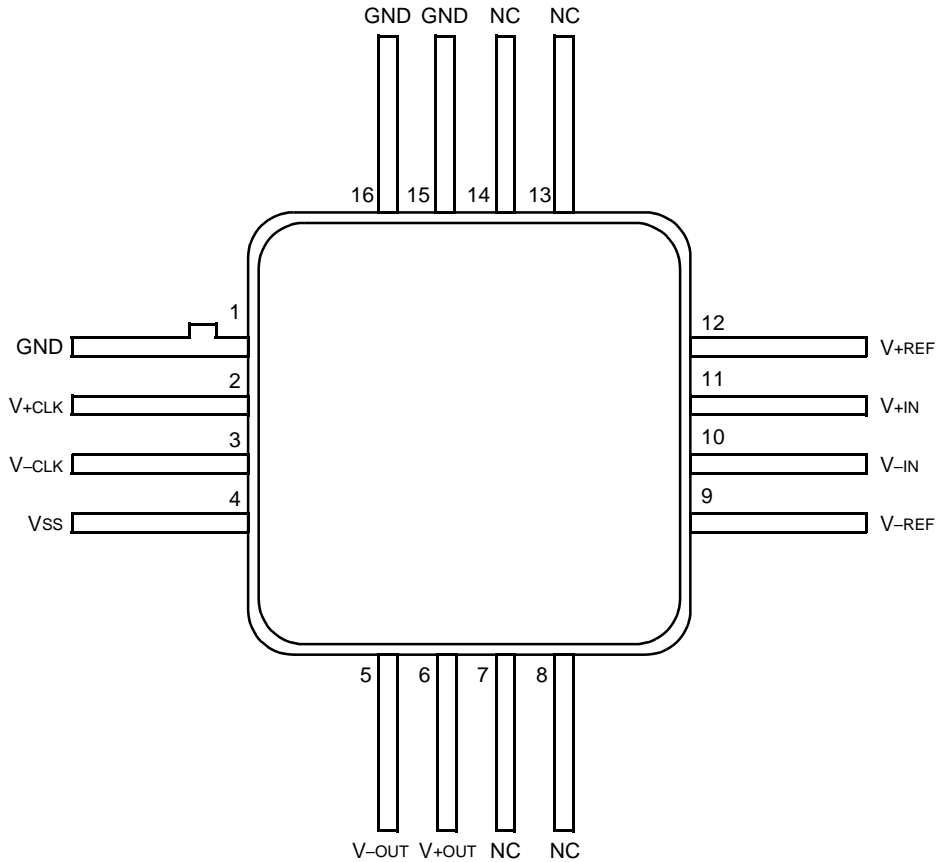

Figure 1. LG1602 Functional Diagram

Pin Information



12-3223(F).ar.2

Figure 2. Pin Diagram

Table 1. Pin Descriptions

Pin	Symbol	Name/Description
2	V+CLK	Clock Input. May be grounded, if not used.
3	V-CLK	Clock Input. May be grounded, if not used.
4	VSS	dc Supply Voltage.
5	V-OUT	Negative Data Output. ac couple or terminate with 50 Ω to GND.
6	V+OUT	Positive Data Output. ac couple or terminate with 50 Ω to GND.
9	V-REF	Data Negative Reference. Bypass to GND with 0.047 μF in series with 5 Ω.
10	V-IN	Negative Data Input. ac couple with 0.047 μF.
11	V+IN	Positive Data Input. ac couple with 0.047 μF.
12	V+REF	Data Positive Reference. Bypass to GND with 0.047 μF in series with 5 Ω.
1, 15, 16, Package Back	GND	Ground. For optimum performance, package back should contact board ground plane.
7, 8, 13, 14	NC	No Connection.

Absolute Maximum Ratings

Stresses in excess of the absolute maximum ratings can cause permanent or latent damage to the device. These are absolute stress ratings only. Functional operation of the device is not implied at these or any other conditions in excess of those given in the operational sections of the data sheet. Exposure to absolute maximum ratings for extended periods can adversely affect device reliability.

Table 2. Absolute Maximum Ratings

Parameter	Min	Max	Unit
Supply Voltage Range (V _{SS})	0.5	-7	V
Power Dissipation	—	1	W
Voltage (all pins)	0.5	V _{SS}	V
Clock Input (V _{+CLK} , V _{-CLK})	—	±2	V
V _{+REF} - V _{+IN}	—	±2	V
V _{-REF} - V _{-IN}	—	±2	V
Storage Temperature Range	-40	125	°C
Operating Case Temperature Range	0	100	°C

Recommended Operating Conditions

Table 3. Recommended Operating Conditions

Parameter	Symbol	Min	Max	Unit
Case Temperature	t _{CASE}	0	75	°C
Power Supply	V _{SS}	-4.7	-5.7	V

Handling Precautions

Although protection circuitry has been designed into this device, proper precautions should be taken to avoid exposure to electrostatic discharge (ESD) during handling and mounting. Lucent employs a human-body model (HBM) and a charged-device model (CDM) for ESD-susceptibility testing and protection design evaluation. No industry-wide standard has been adopted for the CDM. However, a standard HBM (resistance = 1500 Ω, capacitance = 100 pF) is widely used and, therefore, can be used for comparison purposes. The HBM ESD threshold presented here was obtained by using these circuit parameters.

Table 4. ESD Threshold

HBM ESD Threshold	
Device	Voltage
LG1602	≥200 V

Mounting and Connections

Certain precautions must be taken when using solder. For installation using a constant temperature solder, temperatures of under 300 °C may be employed for periods of time up to 5 seconds, maximum. For installation with a soldering iron (battery operated or nonswitching only), the soldering tip temperature should not be greater than 300 °C and the soldering time for each lead must not exceed 5 seconds.

Electrical Characteristics

Bit rate = 2.488 Mb/s NRZ and data pattern = $2^{23} - 1$ PRBS, unless otherwise indicated. See Figure 3 for the timing and signal levels and Figure 5 for the test circuit, when using the TF1001A test fixture.

Note: Minimum and maximum values are testing requirements. Typical values are characteristics of the device and are the result of engineering evaluations. Typical values are for information purposes only and are not part of the testing requirements.

Parameter	Symbol	Conditions	LG1602AXB			LG1602BxB			Unit
			t _{CASE} = 25 °C V _{SS} = -5.2 V			t _{CASE} = 0 °C— 75 °C V _{SS} = -4.9 V to -5.5 V			
			Min	Typ	Max	Min	Typ	Max	
Maximum Bit Rate	—	BER = 10 ⁻⁹	3	—	—	2.5	—	—	GHz
Data Input Voltage V _H - <V> + <V> - V _L	—	t _R , t _F ≤ 165 ps (20%—80%)	200	—	800	200	—	900	mV
Data Input Sensitivity	—	BER = 10 ⁻⁹ , limited clock phase margin	—	20	—	—	20	—	mV
Clock Input Voltage V _H - <V> + <V> - V _L	—	t _R , t _F ≤ 85 ps (20%—80%), duty cycle = 50% ± 10%	500	—	1000	200	—	900	mV
Clock Phase Margin	—	—	250	360	—	250	360	—	ps
Clock Phase Minimum	t ₁	Data transition to negative edge of CLOCK IN	—	—	—	—	150	205	ps
Clock Phase Maximum	t ₂	Data transition to negative edge of CLOCK IN	—	—	—	455	510	—	ps
Clock Phase Center	t _C	Data transition to negative edge of CLOCK IN	—	330	—	—	330	—	ps
Setup Time	t _S	Valid input data to negative edge of CLOCK IN	—	185	—	—	185	205	ps
Hold Time	t _H	Negative edge CLOCK IN to valid DATA IN	—	-73	—	—	-73	-53	ps
Propagation Delay	t _{PD}	CLOCK IN negative edge to output transition	—	1200	—	—	1200	—	ps
Output Voltage (V _H - V _L)	—	Outputs ac coupled (see Figure 5)	500	600	—	500	600	—	mV
Output Transition Time	—	20%—80%, outputs ac coupled	—	—	100	—	—	100	ps
Output Return Loss	—	1 MHz—2 GHz, outputs ac coupled	—	15	—	—	15	—	dB
Data Input Return Loss	—	100 kHz—300 kHz	—	10	—	10	—	—	dB
		0.3 MHz—1500 MHz	—	15	—	15	—	—	dB
		1.5 GHz—1.8 GHz	—	15	—	15	—	—	dB
Clock Input Return Loss	—	2.4 GHz—2.6 GHz	—	15	—	15	—	—	dB
Power Supply Current	—	—	—	115	—	—	115	—	mA
Thermal Resistance	—	Junction to case bottom	—	20	—	—	20	—	°C/W

Electrical Characteristics (continued)

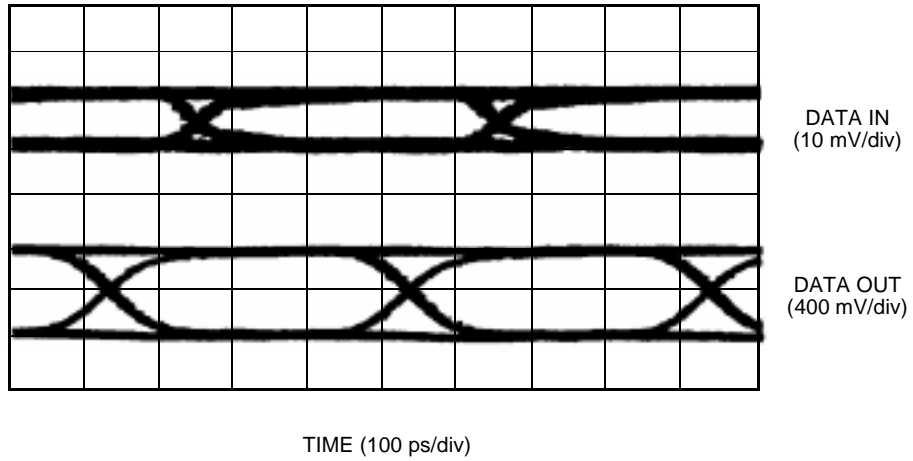

Figure 5. Typical Performance

5-7670(F)r.1

Outline Diagram

16-Pin, Glass-Metal, Surface-Mount Package

Dimensions are in inches.

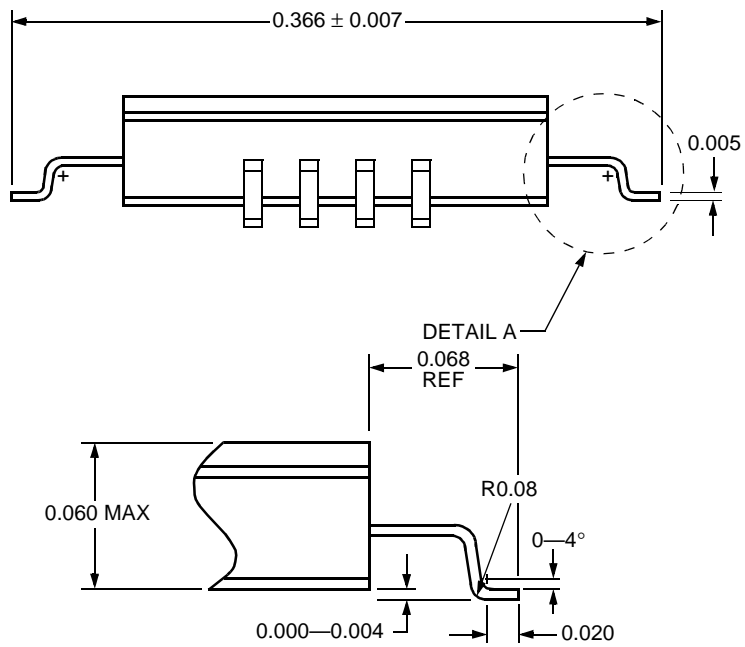
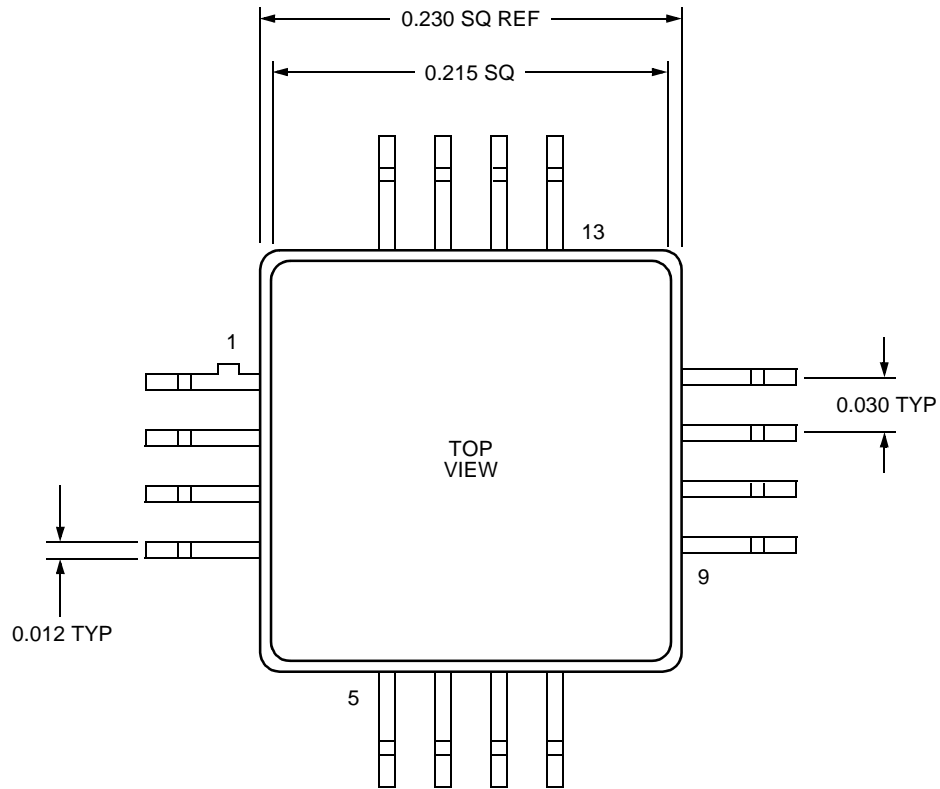

DETAIL A

Ordering Information

Device Code	Package	Temperature	Comcode (Ordering Number)
LG1602AXB	Packaged on 16 mm tape and reel	0 °C to 75 °C	106385297
LG1602BXB	Packaged in flat pack container	0 °C to 75 °C	106995715
TF1001A	Test fixture	—	106497589

Notes

For additional information, contact your Microelectronics Group Account Manager or the following:

INTERNET: <http://www.lucent.com/micro>

E-MAIL: docmaster@micro.lucent.com

N. AMERICA: Microelectronics Group, Lucent Technologies Inc., 555 Union Boulevard, Room 30L-15P-BA, Allentown, PA 18103

1-800-372-2447, FAX 610-712-4106 (In CANADA: **1-800-553-2448**, FAX 610-712-4106)

ASIA PACIFIC: Microelectronics Group, Lucent Technologies Singapore Pte. Ltd., 77 Science Park Drive, #03-18 Cintech III, Singapore 118256

Tel. (65) 778 8833, FAX (65) 777 7495

CHINA: Microelectronics Group, Lucent Technologies (China) Co., Ltd., A-F2, 23/F, Zao Fong Universe Building, 1800 Zhong Shan Xi Road, Shanghai 200233 P. R. China **Tel. (86) 21 6440 0468, ext. 316**, FAX (86) 21 6440 0652

JAPAN: Microelectronics Group, Lucent Technologies Japan Ltd., 7-18, Higashi-Gotanda 2-chome, Shinagawa-ku, Tokyo 141, Japan

Tel. (81) 3 5421 1600, FAX (81) 3 5421 1700

EUROPE: Data Requests: MICROELECTRONICS GROUP DATALINE: **Tel. (44) 1189 324 299**, FAX (44) 1189 328 148

Technical Inquiries: GERMANY: **(49) 89 95086 0** (Munich), UNITED KINGDOM: **(44) 1344 865 900** (Ascot),

FRANCE: **(33) 1 40 83 68 00** (Paris), SWEDEN: **(46) 8 594 607 00** (Stockholm), FINLAND: **(358) 9 4354 2800** (Helsinki),

ITALY: **(39) 02 6608131** (Milan), SPAIN: **(34) 1 807 1441** (Madrid)

Lucent Technologies Inc. reserves the right to make changes to the product(s) or information contained herein without notice. No liability is assumed as a result of their use or application. No rights under any patent accompany the sale of any such product(s) or information.

