

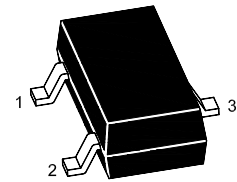

Features

- Low forward voltage
- Fast reverse recovery time
- Small total capacitance

SOT-23

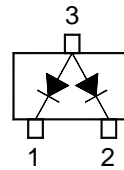

1.Cathode 2.Cathode 3.Anode

Marking : A1

Absolute Maximum Ratings ($T_a = 25\text{ }^\circ\text{C}$)

Parameter	Symbol	Value	Unit
Maximum Peak Reverse Voltage	V_{RM}	85	V
Reverse Voltage	V_R	80	V
Average Rectified Forward Current	$I_{F(AV)}$	100	mA
Maximum Peak Forward Current	I_{FM}	300	mA
Non-repetitive Peak Forward Surge Current (10 ms)	I_{FSM}	2	A
Power Dissipation	P_{tot}	350	mW
Junction Temperature	T_j	150	$^\circ\text{C}$
Storage Temperature Range	T_{stg}	- 55 to + 150	$^\circ\text{C}$

Characteristics at $T_a = 25\text{ }^\circ\text{C}$

Parameter	Symbol	Max.	Unit
Forward Voltage at $I_F = 100\text{ mA}$	V_F	1.2	V
Reverse Current at $V_R = 30\text{ V}$ at $V_R = 80\text{ V}$	I_R	0.1 0.5	μA
Total Capacitance at $V_R = 0$, $f = 1\text{ MHz}$	C_T	4	pF
Reverse Recovery Time at $I_F = 10\text{ mA}$	t_{rr}	4	ns



Ratings And Characteristic Curves

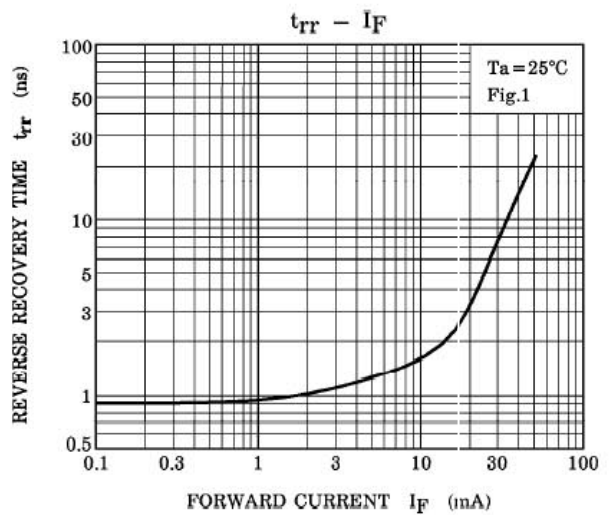
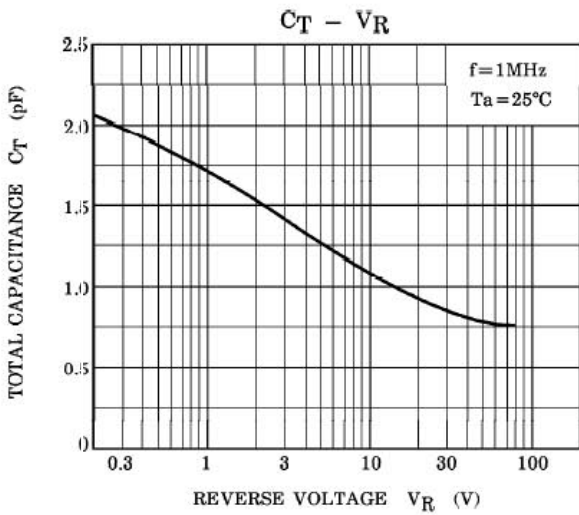
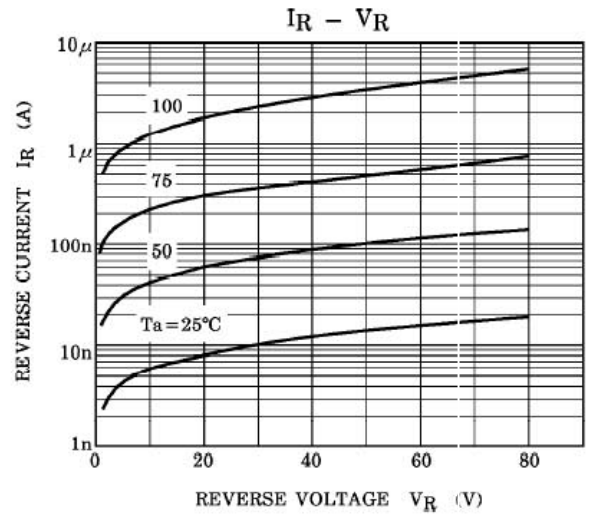
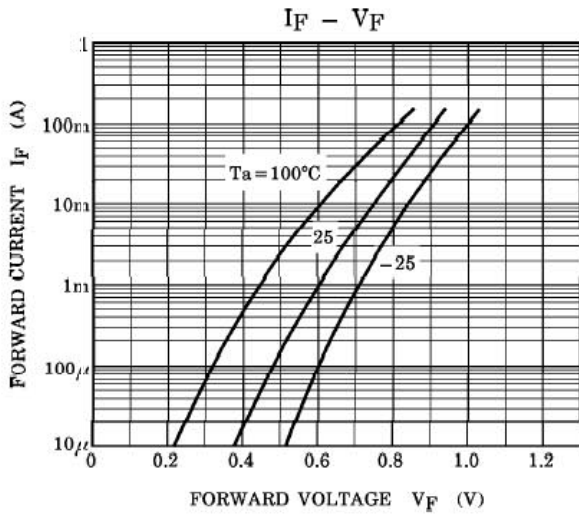
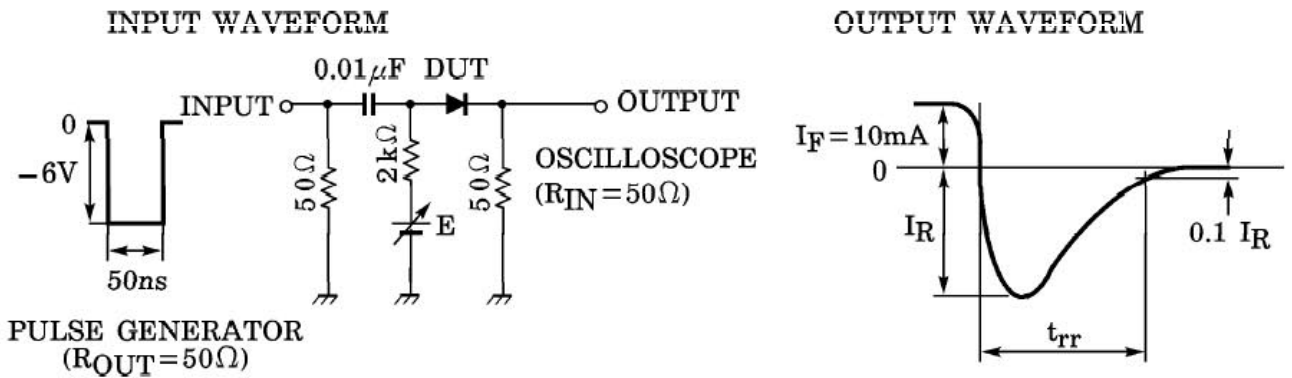
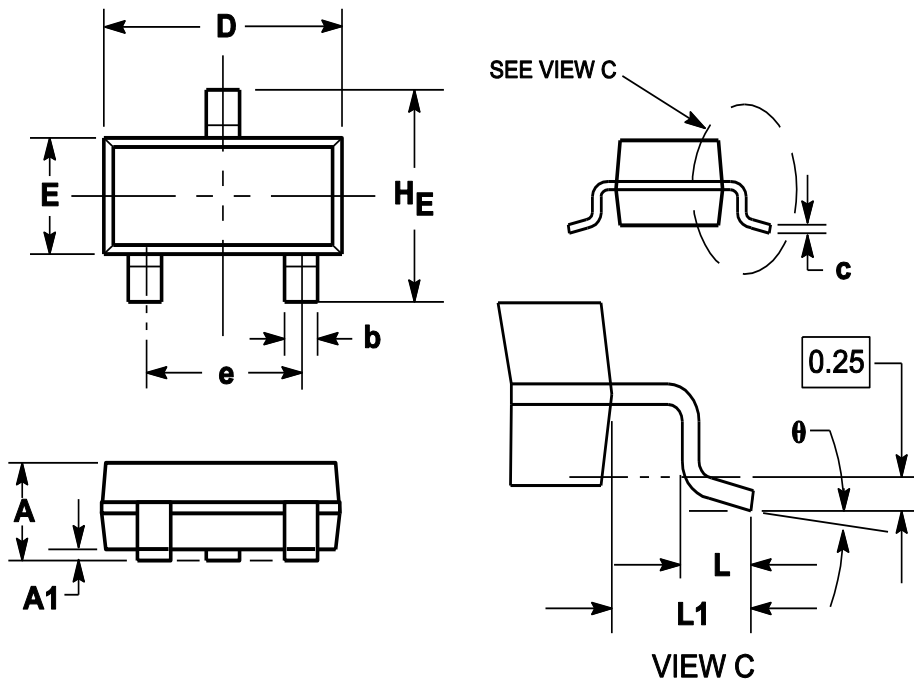

Fig.1 Reverse recovery time (t_{rr}) test circuit





Package Outline
SOT-23



Symbol	Dimensions in millimeter		
	Min.	Typ.	Max.
A	0.900	1.025	1.150
A1	0.000	0.050	0.100
b	0.300	0.400	0.500
c	0.080	0.115	0.150
D	2.800	2.900	3.000
E	1.200	1.300	1.400
HE	2.250	2.400	2.550
e	1.800	1.900	2.000
L1	0.550REF		
L	0.300		0.500
θ	0°		8°

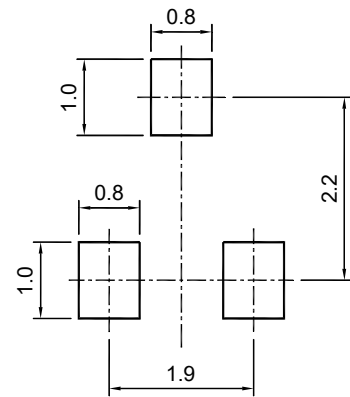

SOT-23

Recommended soldering pad

Ordering information

Device	Package	Shipping
1SS181	SOT-23	3000/Tape&Reel(7inches)