

CASE OUTLINE DRAWINGS & DIMENSIONS

NS257

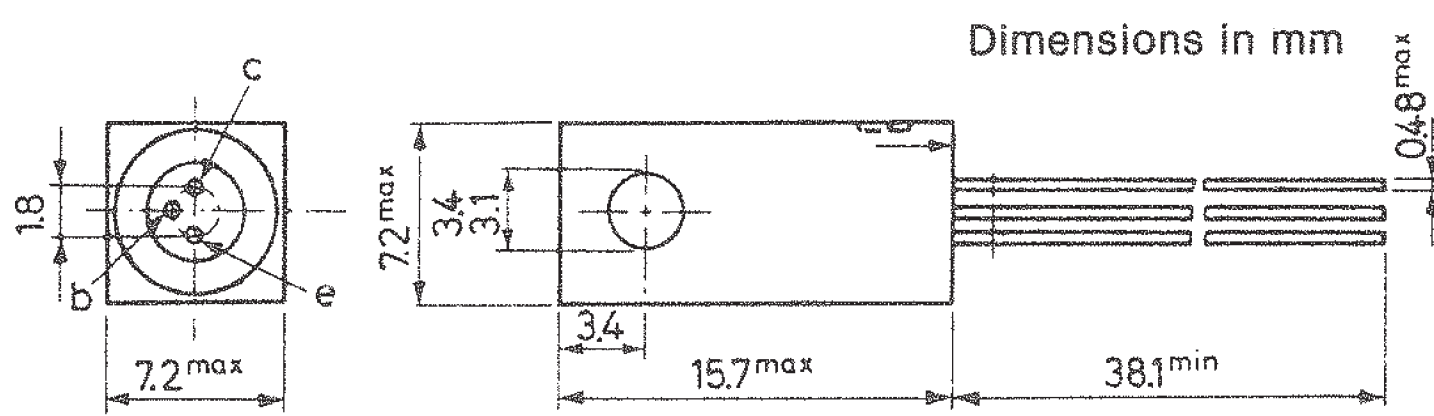

TO-1

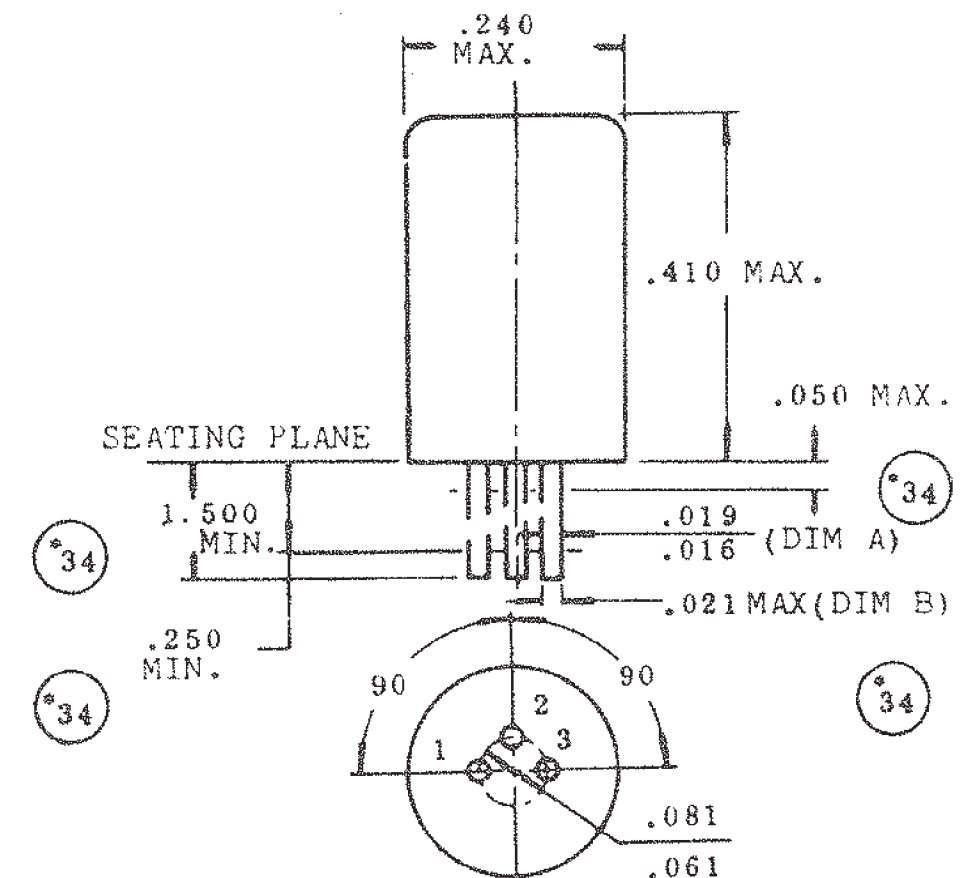

TO-18

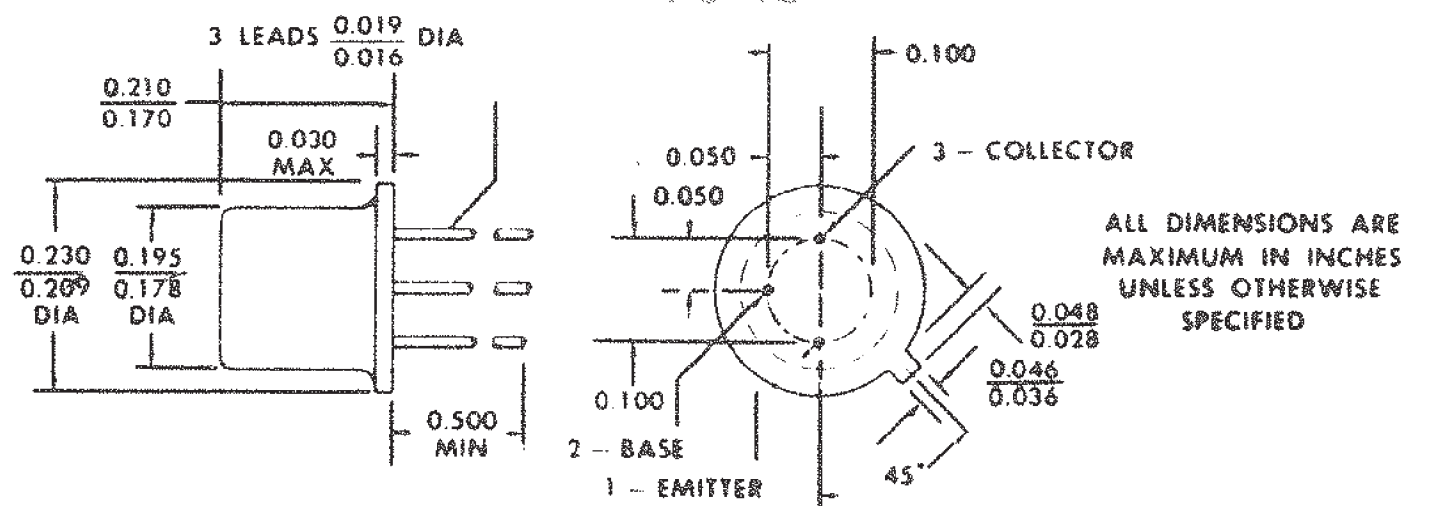

THE COLLECTOR IS ELECTRICAL CONTACT WITH THE CASE.

ALL JEDEC TO-18 DIMENSIONS AND NOTES ARE APPLICABLE.