

New Jersey Semi-Conductor Products, Inc.

20 STERN AVE.
 SPRINGFIELD, NEW JERSEY 07081
 U.S.A.

TELEPHONE: (201) 376-2922
 (212) 227-6005
 FAX: (201) 376-8960

Device	Polar	Can	P _{tot} 25 °C W	I _C max mA	V _{BR} min			I _{CBO} max nA	hFE		V _{CE sat}		C _{ob} max pF	F _T min MHz	N _F max dB	f _c kHz	t _{on} max ns	t _{off} max ns	I _e mA	Remarks	
					C _B V	C _E V	E _B V		min	max	VCE V	I _C mA									
2N 1420	N	39	1.00	1000	60	30	5.0	1000	100	300	10	150	1.50	150	35	50				V _{CE sat} @ 500 mA	0.5 V
2N 1507	N	39	1.00	1000	60	30	5.0	1000	100	300	10	150	1.50	150	35	50				V _{CE sat} @ 500 mA	0.5 V
2N 1564	N	39	0.60	100	80	60	5.0	1000	20	50	5	5	1.00	2	10	30					
2N 1565	N	39	0.60	100	80	60	5.0	1000	40	100	5	5	1.00	2	10	60					
2N 1565 A	N	39	0.60	100	80	60	8.0	500	40	100	5	5	0.60	10	6	60					
2N 1566	N	39	0.60	100	80	60	5.0	1000	80	200	5	5	1.00	2	10	60					
2N 1566 A	N	39	0.60	100	80	60	8.0	500	60	200	5	5	0.60	10	6	100					
2N 1572	N	39	0.60	100	125	80	5.0	1000	20	50	5	5	1.00	10	10	30					
2N 1573	N	39	0.60	100	125	80	5.0	1000	40	100	5	5	1.00	10	10	60					
2N 1574	N	39	0.60	100	125	80	5.0	1000	80	200	5	5	1.00	10	10	60					
2N 1613	N	39	1.00	1000	75	50	7.0	10	40	120	10	150	1.50	150	25	60				V _{CE sat} @ 500 mA	0.5 V
2N 1711	N	39	1.00	1000	75	50	7.0	10	100	300	10	150	1.50	150	25	70				V _{CE sat} @ 500 mA	0.5 V
2N 1711 A	N	39	1.00	1000	75	40	7.0	10	100	300	10	150	1.50	150	25	70	12			V _{CE sat} @ 500 mA	0.5 V
2N 1889	N	39	1.00	1000	100	80	7.0	10	40	120	10	150	5.00	150	15	50	8	1		V _{CE sat} @ 500 mA	0.5 V
2N 1890	N	39	1.00	1000	100	80	7.0	10	100	300	10	150	5.00	150	15	60	8	1		V _{CE sat} @ 500 mA	0.5 V
2N 1893	N	39	1.00	1000	120	100	7.0	10	40	120	10	150	5.00	150	15	50				V _{CE sat} @ 500 mA	0.5 V
2N 1983	N	39	1.00	1000	50	25	5.0	5000	80	240	5	5	0.25	5	45	40					
2N 1990	N	39	0.60	50	100		3.0	1000	20		10	30	0.50	30	20	40					
2N 1990 R	N	18	0.25	50	100		3.0	1000	25		0.5	2	0.50	2	20	40					
2N 1990 S	N	39	0.60	50	100		3.0	1000	25		0.5	2	0.50	2	20	40					
2N 2102	N	39	1.00	1000	120	65	7.0	2	40	120	10	150	0.50	150	15	120				hFE @ 1 A	10
2N 2102 A	N	39	1.00	1000	120	65	7.0	2	40	120	10	150	0.50	150	15	60				hFE @ 1 A	10
2N 2192	N	39	1.00	1000	60	40	5.0	10	100	300	10	150	0.25	150	20	50	6	1		hFE @ 1 A	15
2N 2192 A	N	39	1.00	1000	60	40	5.0	10	100	300	10	150	0.25	150	20	50	6	1		hFE @ 1 A	15
2N 2192 B	N	39	1.00	1000	60	40	5.0	10	100	300	10	150	0.18	150	20	50				hFE @ 1 A	15
2N 2193	N	39	1.00	1000	80	50	8.0	10	40	120	10	150	0.35	150	20	50				hFE @ 1 A	15
2N 2193 A	N	39	1.00	1000	80	50	8.0	10	40	120	10	150	0.25	150	20	50				hFE @ 1 A	15
2N 2193 B	N	39	1.00	1000	80	50	8.0	10	40	120	10	150	0.18	150	20	50				hFE @ 1 A	15
2N 2194	N	39	1.00	1000	60	40	5.0	10	20	60	10	150	0.35	150	20	50				hFE @ 500 mA	12
2N 2194 A	N	39	1.00	1000	60	40	5.0	10	20	60	10	150	0.25	150	20	50				hFE @ 500 mA	12
2N 2194 B	N	39	1.00	1000	60	40	5.0	10	20	60	10	150	0.18	150	20	50				hFE @ 500 mA	12
2N 2195	N	39	1.00	1000	45	25	5.0	100	20		10	150	0.35	150	20	50					
2N 2195 A	N	39	1.00	1000	45	25	5.0	100	20		10	150	0.25	150	20	50					
2N 2195 B	N	39	1.00	1000	45	25	5.0	100	20		10	150	0.18	150	20	50					
2N 2217	N	39	1.00	800	60	30	5.0	10	20	60	10	150	0.40	150	8	250					

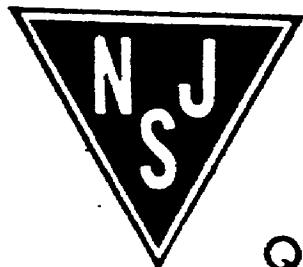
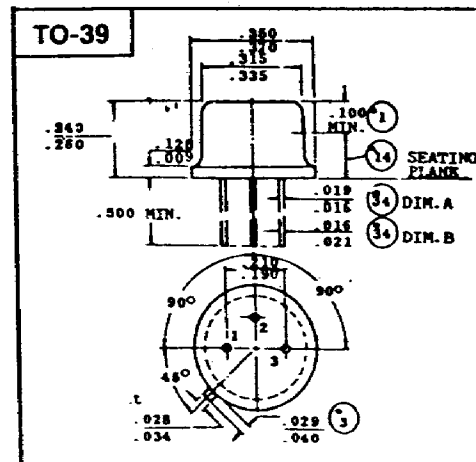

Quality Semi-Conductors

Downloaded from alldatasheet.com